

APPLICATION ACCEPTED AND AMENDMENTS  
ALLOWED 595771  
2-2-90

COMMONWEALTH of AUSTRALIA  
Patents Act 1952

**APPLICATION FOR A STANDARD PATENT**

I/We

SDS-Relais AG

of

Fichtenstrasse 5, D-8024 Deisenhofen, Federal Republic of Germany

hereby apply for the grant of a Standard Patent for an invention entitled:

**Electromagnetic switching device**

which is described in the accompanying complete specification.

Details of basic application(s):-

| <u>Number</u> | <u>Convention Country</u>   | <u>Date</u>      |
|---------------|-----------------------------|------------------|
| P 37 43 122.6 | Federal Republic of Germany | 18 December 1987 |

The address for service is care of DAVIES & COLLISON, Patent Attorneys, of 1 Little Collins Street, Melbourne, in the State of Victoria, Commonwealth of Australia.

DATED this THIRTEENTH day of DECEMBER 1988

To: THE COMMISSIONER OF PATENTS

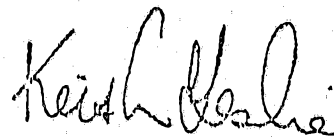

.....  
a member of the firm of  
DAVIES & COLLISON for  
and on behalf of the  
applicant(s)

RECEIVED 13/12/88

Davies & Collison, Melbourne

COMMONWEALTH OF AUSTRALIA  
PATENTS ACT 1952

DECLARATION IN SUPPORT OF CONVENTION OR  
NON-CONVENTION APPLICATION FOR A PATENT

Insert title of invention.

In support of the Application made for a patent for an invention  
entitled: Electromagnetic Switching Device

Insert full name(s) and address(es)  
of declarant(s) being the appli-  
cant(s) or person(s) authorized to  
sign on behalf of an applicant  
company.

I ~~was~~ <sup>am</sup> Sepp Antonitsch  
c/o SDS-Relais AG  
Fichtenstraße 3-5  
D-8024 Deisenhofen  
Federal Republic of Germany

Cross out whichever of paragraphs  
1(a) or 1(b) does not apply

1(a) relates to application made  
by individual(s)  
1(b) relates to applica/ion made  
by company; insert name of  
applicant company.

do solemnly and sincerely declare as follows :-

1. ~~(a) I am the inventor of the invention~~

or (b) I am authorized by SDS-Relais AG  
(address as above)

Cross out whichever of paragraphs  
2(a) or 2(b) does not apply

2(a) relates to application made  
by inventor(s)  
2(b) relates to application made  
by company(s) or person(s) who  
are not inventor(s); insert full  
name(s) and address(es) of inven-  
tors.

the applicant..... for the patent to make this declaration on <sup>its</sup> behalf.  
~~my~~

2. ~~(a) I am the inventor of the invention~~

or (b) Bernhard Dietrich  
Jahnstraße 2  
D-8031 Eichenau  
Federal Republic of Germany

~~is~~ <sup>is</sup> the actual inventor..... of the invention and the facts upon which the applicant.....  
~~are~~ <sup>are</sup> entitled to make the application are as follows :-

State manner in which applicant(s)  
derive title from inventor(s)

Agreement dated July 2, 1981, whereby the applicant  
would, if a patent were granted upon an application made  
by the said inventor, be entitled to have the patent  
assigned to it.

Cross out paragraphs 3 and 4  
for non-convention applications.  
For convention applications,  
insert basic country(s) followed  
by date(s) and basic applicant(s).

3. The basic application..... as defined by Section 141 of the Act <sup>was</sup> made  
~~was~~ in Fed. Rep. of Germany on the 2nd July, 1987  
by SDS-Relais AG  
in ..... on the .....  
by .....  
in ..... on the .....  
by .....

4. The basic application..... referred to in paragraph 3 of this Declaration <sup>was</sup>  
~~was~~ the first application..... made in a Convention country in respect of the invention the subject  
of the application.

Insert place and date of signature.

Declared at Deisenhofen this 21st day of November, 1988

Signature of declarant(s) (no  
attestation required)

*Sepp Antonitsch*  
Sepp Antonitsch, Director  
of SDS-Relais AG

Note: Initial all alterations.

**(12) PATENT ABRIDGMENT (11) Document No. AU-B-26800/88**  
**(19) AUSTRALIAN PATENT OFFICE (10) Acceptance No. 595771**

(Modified Examination)

- (54) Title  
ELECTROMAGNETIC SWITCHING DEVICE
- (51)<sup>4</sup> International Patent Classification(s)  
H01H 050/28      H01F 007/14      H01H 050/22      H01H 051/06  
H01H 051/29
- (21) Application No. : 26800/88      (22) Application Date : 13.12.88
- (30) Priority Data
- (31) Number      (32) Date      (33) Country  
3743122      18.12.87      DE FEDERAL REPUBLIC OF GERMANY
- (43) Publication Date : 22.06.89
- (44) Publication Date of Accepted Application : 05.04.90
- (71) Applicant(s)  
SDS-RELAIS AG
- (72) Inventor(s)  
BERNHARD DIETRICH
- (74) Attorney or Agent  
DAVIES & COLLISON, MELBOURNE
- (56) Prior Art Documents  
DE 3417891  
AU 15560/47 H01H 51/06, 51/29, 50/04, 50/06, 51/34, 51/58
- (57) Claim

1. An electromagnetic switching device, comprising  
a contact arrangement including at least one stationary  
contact disposed in a housing member and a contact slider in-  
serted in said housing member and carrying a contact movable  
relative to the stationary contact,

a solenoid actuator inserted in said housing member and  
including a bobbin, at least one coil and an armature movable  
substantially parallel to the direction of movement of the  
contact slider, and

at least one two-armed lever pivotable about a fixed  
bearing location, one arm of said lever being ~~coupled~~<sup>operatively linked</sup> to an  
end of said contact slider and the other arm being ~~coupled~~<sup>operatively linked</sup> to

(11) AU-B-26800/88  
(10) 595771

-2-

an end of said armature,

wherein said bearing location for said lever comprises at least one guide member which projects from the outside of said solenoid actuator substantially parallel to the direction of movement of said armature and extends through a recess formed in said lever, and a bearing surface formed on said housing member for supporting an outer surface of said lever in the vicinity of said recess.

595771

COMMONWEALTH OF AUSTRALIA  
PATENTS ACT 1952  
COMPLETE SPECIFICATION

NAME & ADDRESS  
OF APPLICANT:

SDS-Relais AG  
Fichtenstrasse 5  
D-8024 Deisenhofen  
Federal Republic of Germany

This document contains the  
amendments made under  
Section 49.

and is correct for printing.

NAME(S) OF INVENTOR(S):

Bernard DIETRICH

ADDRESS FOR SERVICE:

DAVIES & COLLISON  
Patent Attorneys  
1 Little Collins Street, Melbourne, 3000.

COMPLETE SPECIFICATION FOR THE INVENTION ENTITLED:

Electromagnetic switching device

The following statement is a full description of this invention, including the best method of performing it known to me/us:-

## 1 DESCRIPTION

5 The present invention relates to an electromagnetic switching device of the general type known from West German Patent Specification 3,417,891. In this prior art switching device, a contact slider is coupled to the armature of a solenoid actuator, which armature is reciprocable parallel to the slider, via pairs of levers that are pivotally mounted on journals provided on a housing base. Upon assembly, the solenoid actuator is first assembled alone, whereupon the levers are installed in fitting their two arms on the ends of the armature and contact slider. The thus assembled arrangement is then mounted in the housing base, and in this process, bores formed in the levers must simultaneously be fitted onto the journals.

10  
15 Due to the fact that, prior to the final mounting in the housing member, the assembled arrangement mentioned above is not positioned in rigid relationship, the assembly step is a rather difficult operation. It is made still more difficult by the fact that the spacing between the journals does not exactly correspond to the spacing between the bores formed in the levers, because in addition to unavoidable machining tolerances there must be some bearing clearance between the ends of the armature and contact slider, on the one hand, and the ends of the levers, on the other hand, especially when the journals are inserted as separate elements in the housing base. A particular difficulty will arise when the solenoid actuator comprises a permanent magnet for achieving a polarized switching performance, which magnet will pull the armature at random to either one of its limit positions.

20  
25  
30 For all these reasons, the assembly of the known switching device is troublesome and time-consuming and in many cases cannot be effected without auxiliary means.

35 It is an object of the present invention to obviate the drawbacks existing in the prior art and provide a switching device of the type specified above designed in such a way that it may be assembled more rapidly and easily.

To meet this object, the electromagnetic switching device of the invention comprises a contact arrangement including at

1 least one stationary contact disposed in a housing member and  
 a contact slider inserted in the housing member and carrying a  
 contact movable relative to the stationary contact, a solenoid  
 5 actuator inserted in the housing member and including a bob-  
 bin, at least one coil and an armature movable substantially  
 parallel to the direction of movement of the contact slider  
 and at least one two-armed lever pivotable about a fixed bear-  
 ing location, one arm of the lever being <sup>operatively linked</sup> ~~coupled~~ to an end of  
 the contact slider and the other arm being <sup>operatively linked</sup> ~~coupled~~ to an end  
 10 of the armature, wherein the bearing location for the lever  
 comprises at least one guide member which projects from the  
 outside of the solenoid actuator substantially parallel to the  
 direction of movement of the armature and extends through a  
 recess formed in the lever, and a bearing surface formed on  
 15 the housing member for supporting an outer surface of the  
 lever in the vicinity of the recess.

In this device, the or each lever is fixed to the sole-  
 noid actuator in the direction of its pivot axis, i.e. in the  
 direction in which the assembly unit composed of solenoid act-  
 20 uator, contact slider and lever or levers is inserted in the  
 housing member, so that the components of the assembly unit  
 are already held in defined positions relative to each other  
 and the inserting step does not require any probing into a  
 bearing location, as in the known device. Rather, the entire  
 25 assembly unit can be inserted simply in such a way that the  
 bearing surface formed by the housing member comes to lie on  
 the outside of the guide member for the respective lever. Such  
 an inserting operation may easily be performed manually with-  
 out any auxiliary means, irrespective of the actual position  
 30 of the contact slider.

In a preferred embodiment, the bearing surface, which  
 faces the lever, is configured to form a knife-edge bearing,  
 to provide a bearing with minimum friction even though there  
 is no journal.

35 In another embodiment, the guide member and the recess  
 are of elongate shape in the direction of an axis about which  
 the lever is pivotable. This results in a tilt-free bearing of  
 the lever, which is guided on the respective assembly with re-



1 spect to all degrees of freedom expect for an outward movement which in turn is prevented by the bearing surface of the housing member.

5 Advantageously, each lever is formed with two recesses which are open towards opposite sides, and a guide member extends through each of the recesses. This measure results in a support of the levers which is beneficial to the stability of the aforementioned assembly unit and thus also results in the assembly unit being received without any difficulties in the  
10 base during the insertion operation.

As another development of the invention, two levers are disposed on opposite sides of the solenoid actuator to constitute a parallelogram linkage together with the contact slider and the armature, the contact slider and armature having stepped ends extending through openings formed in the arms of both levers and being supported by the levers to constitute operative connections of the parallelogram linkage, due to which the prior known advantages of a low-friction bearing of all movable parts is retained. The openings formed in the lever arms act to permit the levers to be simply inserted irrespective of the position of the armature.  
15  
20

Further measures may be combined with the concept of the present invention to achieve a monostable switching performance with a compact overall structure.

25 A preferred embodiment of the invention will be explained in detail with reference to the drawing, in which

Figure 1 is a longitudinal sectional view of an electromagnetic switching device taken along the line I-I in Figure 2, and

30 Figure 2 is a cross-section taken along the line II-II in Figure 1.

The electromagnetic switching device illustrated in the drawing is accommodated in a housing composed of a base 10 and a housing cap 11. In the lower portion of the base 10, as viewed in Figure 1, there are provided a plurality of switching chambers each including two stationary contacts 12 disposed in mutually aligned relationship. As will be apparent from Figure 2, these stationary contacts 12 comprise lower  
35

1 terminals 13 projecting through the base 10 and upper termin-  
als 14 projecting through the housing cap 11. The lower ter-  
minals 13 are used for insertion into a printed circuit board  
(not illustrated) while the upper terminals 14 are provided  
5 for further connections and are disposed in a recessed portion  
15 at the top of the housing cap 11.

A contact slider 16 is provided with a number of movable  
bridge contacts 17b which are supported through leaf springs  
17a, each bridge contact 17b cooperating with a pair of mutu-  
ally aligned stationary contacts 12. In the embodiment illus-  
10 trated in Figure 1, the stationary contacts 12 are disposed in  
such a way and the movable contacts 17b are biased in such a  
way that a total of four normally closed double-break contact  
couples and one normally open contact couple, also of double-  
break type, are formed.  
15

In the upper portion of the housing, as viewed in Figure  
1, there is accommodated a solenoid actuator 18 which compris-  
es two coils 20 each wound on a bobbin 19, a permanent magnet  
21 disposed therebetween, an armature 22 extending through a  
20 central hole formed in the bobbins 19 and in the permanent  
magnet 21 and reciprocable in the axial direction of the  
coils, and two yokes 23 extending over the outer sides of the  
bobbins 19. The armature 22 is mounted on a guide bar 24 which  
extends in coaxial relationship with the coils 20 and the ends  
25 of which pass through openings left between the two yokes 23.

The reciprocating movement of the armature 22 is trans-  
mitted to the contact slider 16 via two levers 25, 26. Either  
arm of each lever 25, 26 is provided at its end with an open-  
ing through which a portion of the respective stepped outer  
30 end of the guide bar 24 and of the respective end portions 27,  
28 of the contact slider 16 is passed. As illustrated in Fig-  
ure 2, the remainder of the stepped end of the guide bar 24  
and, respectively, the remainder of the end portions 27, 28 of  
the contact slider 16 are supported in steps 24a, 24b and 28a,  
35 28b (shown in phantom lines) at the ends of the levers 25, 26  
facing the solenoid actuator 18 and the contact slider 16, re-  
spectively.

As will be apparent from Figure 1, the lower yoke 23 is

1 inserted between a pair of approximately parallelepipedic  
guide members 30 which project outwardly from the bobbin 19  
and extend through recesses 31 formed in the levers 25, 26.  
The guide members 30 serve to support the levers 25, 26 for  
5 pivotal movement about pivot axes which extend normal to the  
plane of the drawing in Figure 1 and of which one is indicated  
at 29 in Figure 2. As will be apparent from Figure 2, the two  
guide members 30 are disposed on opposite sides of the lower  
yoke 23 at a spacing which is slightly larger than the width  
10 of the yoke 23, the guide members 30 being mutually aligned  
along the pivot axis 29. The recesses 31 formed in the levers  
25, 26 are configured as cut-outs which are open towards the  
lateral edge of the levers such that the levers are fixed in  
their proper position by the broad sides of the guide members  
15 30 in the upward and downward directions and by the narrow  
inward sides of the guide members 30 in left-hand and right-  
hand directions (as viewed in Figure 2).

Thus, each lever is guided in either direction along the  
pivot axis 29. Any outward movement of the levers 25, 26 is  
20 prevented by bearing surfaces 32 integral with the base 10.  
Each bearing surface 32 includes a convex portion facing the  
respective lever 25, 26 so as to minimize the bearing friction  
in the way of a knife-edge bearing. The spacing between the  
bearing surfaces 32 is dimensioned so that, upon insertion of  
25 the solenoid actuator 18, the outer surfaces of the guide  
members 30 may pass therebetween. The sectional plane II-II  
illustrated in Figure 1 extends in the tangent plane between  
the right-hand bearing surface 32 and the guide member 30.

The levers 25, 26, the armature 22, and the contact slid-  
30 er 16 together constitute a parallelogram linkage supported at  
the two pivot axes 29 to convert the reciprocating movement of  
the armature 22 into a reciprocating countermovement of the  
contact slider 16 which extends in parallel thereto. All of  
the openings in the levers 25, 26 are slightly wedge-shaped so  
35 as not to obstruct the free movability of the parallelogram  
linkage.

Figure 1 furthermore shows a leaf spring 33 the free end  
of which acts on the end portion 27 of the contact slider 16

1 projecting through the recess in the lever 25, so that the  
contact slider is biased towards its right-hand limit position  
(as viewed in Figure 1). The other half of the leaf spring 33,  
5 while still being within the housing cap 11, is inserted into  
the base 10 in such a way that it is disposed on the outside  
of an integrally formed portion 34, which constitutes the  
outer bearing surface 32 for the lever 25, and extends upward-  
ly from the inner surface of the base 10.

10 During assembly, the solenoid actuator 18 is first assem-  
bled from the components 19 to 24 and is then fitted with the  
two levers 25, 26 and the contact slider 16 to form an assem-  
bly unit. As the levers 25, 26 already in this condition are  
guided and retained on a part of the solenoid actuator 18,  
15 viz. on the guide members 30 provided on the bobbin 19, and  
therefore also retain the contact slider 16 in a defined man-  
ner, it is easily possible to handle this assembly unit and  
insert it properly into the base 10 so that the outer ends of  
the guide members 30 are fitted between the bearing surfaces  
20 32 provided on the integrally formed portions 34 of the base  
10. In the inserted state, the levers 25, 26 are also retained  
by the bearing surfaces 32 against any outward movement. Fin-  
ally, the leaf spring 33, if provided, is inserted so that the  
switching device is ready for operation after sealing by means  
of the housing cap 11.

25 In operation and for switching-over from the inoperative  
position illustrated in Figure 1, the right-hand coil 20 is  
energized so that the armature 22 is pulled to the right-hand  
limit position as viewed in Figure 1, whereby the levers 25,  
26 turn about their pivot axes 29 and the contact slider 16 is  
30 shifted towards the left against the bias of the leaf spring  
33. Upon de-energization of the coil 20 the parallelogram  
linkage is returned by the leaf spring 33 to the inoperative  
position shown in Figure 1. When the leaf spring 33 is not  
provided, this return is effected by energization of the left-  
35 hand coil 20 as viewed in Figure 1. It is also possible, in-  
stead of energizing only the respective one coil, to apply  
current to both coils simultaneously but in opposite direc-  
tions for the two travelling directions of the armature 22.

THE CLAIMS DEFINING THE INVENTION ARE AS FOLLOWS.

1. An electromagnetic switching device, comprising  
 a contact arrangement including at least one stationary contact disposed in a housing member and a contact slider inserted in said housing member and carrying a contact movable relative to the stationary contact,

a solenoid actuator inserted in said housing member and including a bobbin, at least one coil and an armature movable substantially parallel to the direction of movement of the contact slider, and

at least one two-armed lever pivotable about a fixed bearing location, one arm of said lever being ~~coupled~~<sup>operatively linked</sup> to an end of said contact slider and the other arm being ~~coupled~~<sup>operatively linked</sup> to an end of said armature,

wherein said bearing location for said lever comprises at least one guide member which projects from the outside of said solenoid actuator substantially parallel to the direction of movement of said armature and extends through a recess formed in said lever, and a bearing surface formed on said housing member for supporting an outer surface of said lever in the vicinity of said recess.

2. The switching device of claim 1, wherein said bearing surface, which faces said lever, is configured to form a knife-edge bearing.

3. The switching device of claim 1, wherein said guide mem-



ber and said recess are of elongate shape in the direction of an axis about which the lever is pivotable.

4. The switching device of claim 1, wherein said lever is formed with two recesses which are open towards opposite sides, a guide member extending through each of said recesses.

5. The switching device of claim 1, wherein two levers are disposed on opposite sides of said solenoid actuator to constitute a parallelogram linkage together with said contact slider and said armature, said contact slider and armature having stepped ends extending through openings formed in the arms of both levers and being supported by said levers to constitute operative connections of said parallelogram linkage.

6. The switching device of claim 5, including a spring for biasing said contact slider towards a limit position, said spring being fixed in said housing member on the side of one of said levers remote from said solenoid actuator and bearing against an end of said lever.

7. The switching device of claim 5, including a spring for biasing said contact slider towards a limit position, said spring being fixed in said housing member on the side of one of said levers remote from said solenoid actuator and bearing against an end of one of said contact slider and said armature, said end extending through the respective opening in said lever.

8. The switching device of claim 6, wherein said spring is a leaf spring inserted in said housing member in such a way that its fixed end is disposed on the outer side of an integrally formed portion which constitutes said bearing surface for said lever.

9. A switching device substantially as hereinbefore described with reference to the accompanying drawings.

Dated this 24th day of January, 1990.

DAVIES & COLLISON  
Patent Attorneys for  
SDS-RELAIS AG.



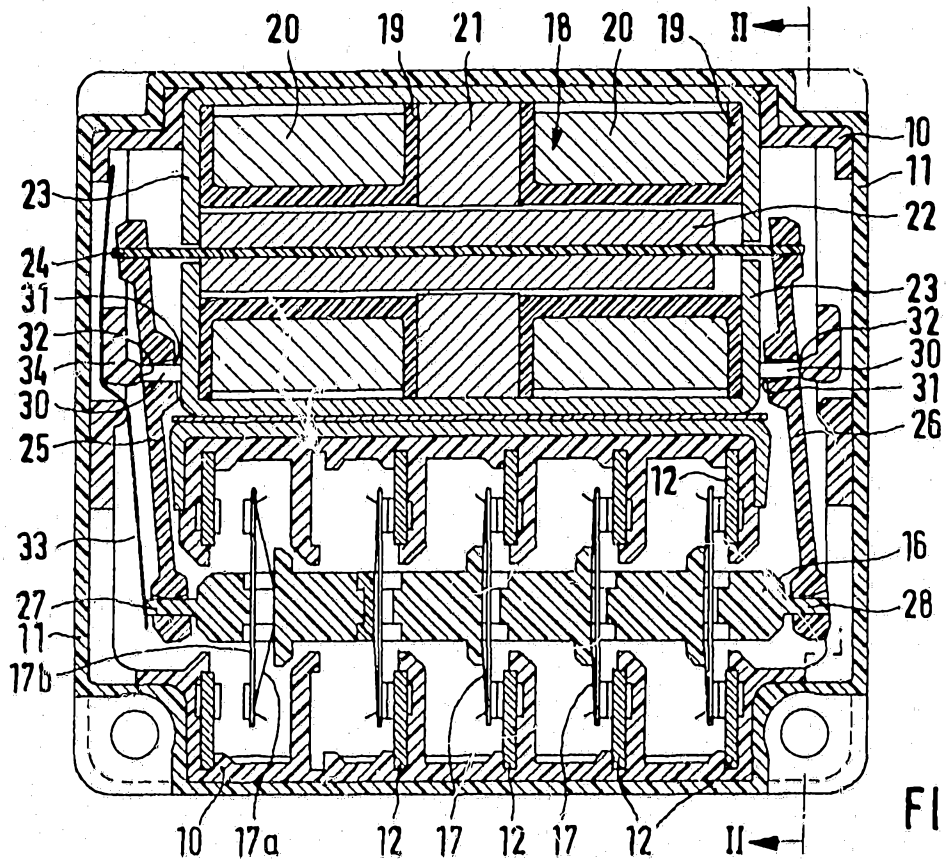

FIG. 1

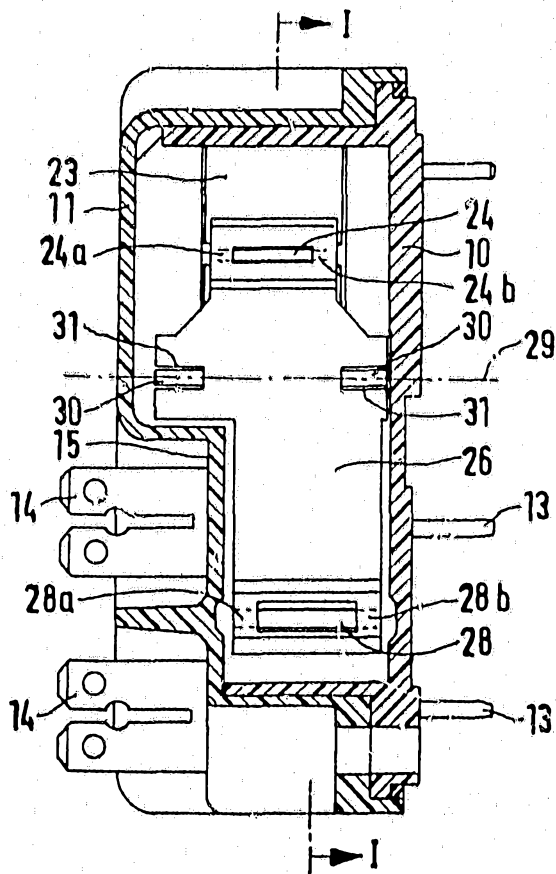

FIG. 2