

F. C. WEIR.
Steam-Boiler.

No. 214,855.

Patented April 29, 1879.

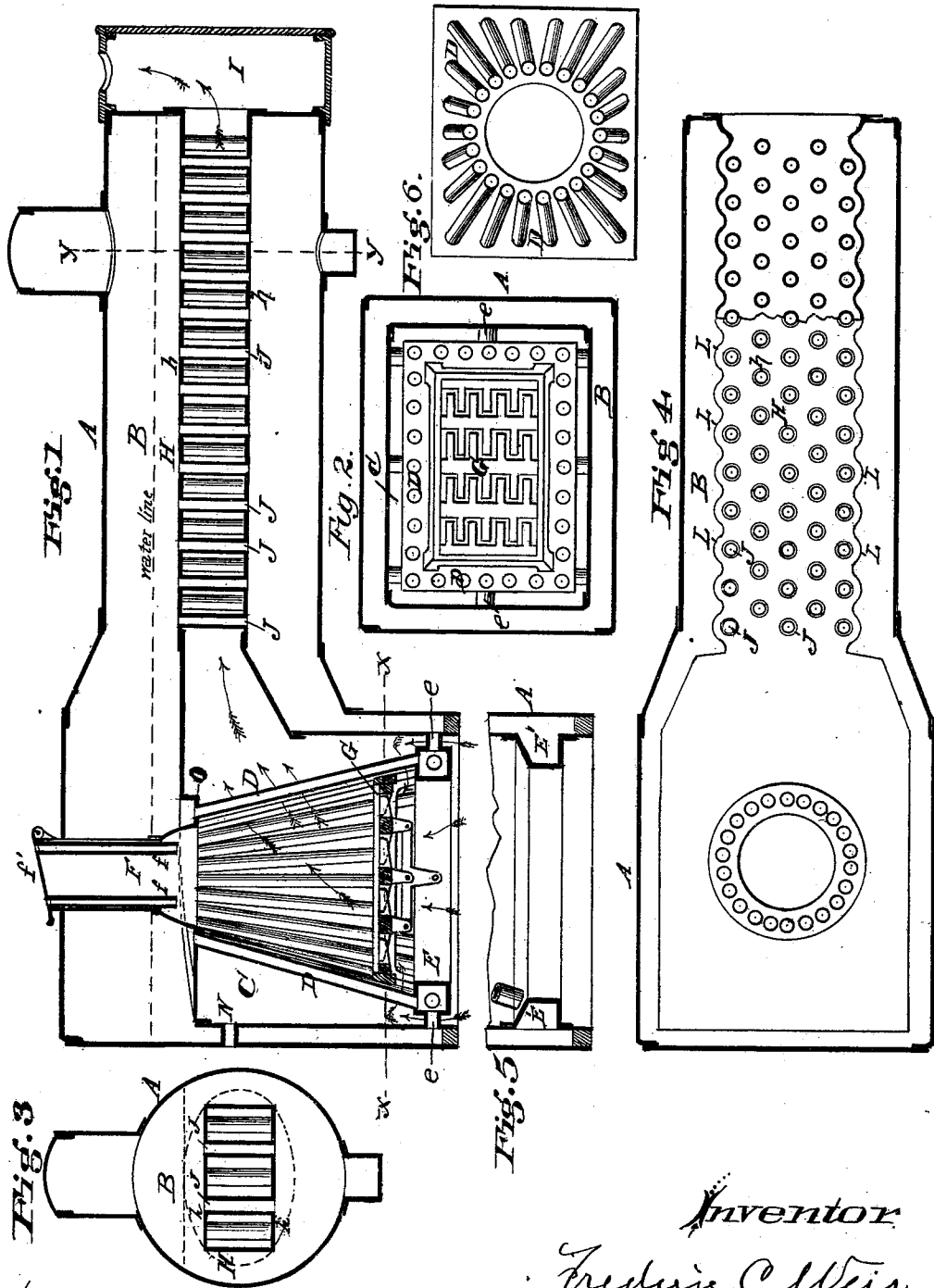

Attest
Edgar Gross
Chas. Clark

Inventor
Frederic C. Weir

UNITED STATES PATENT OFFICE.

FREDERIC C. WEIR, OF CINCINNATI, OHIO.

IMPROVEMENT IN STEAM-BOILERS.

Specification forming part of Letters Patent No. 214,855, dated April 29, 1879; application filed February 1, 1879.

To all whom it may concern:

Be it known that I, FREDERIC C. WEIR, of Cincinnati, Hamilton county, State of Ohio, have made certain new and useful Improvements in Steam-Boilers, of which the following is a specification.

My invention relates more particularly to the construction of a locomotive or fire-box boiler, but may be applied to any horizontal boiler.

It consists, first, in the construction of a vertical tubular grate, it forming a vertical tubular fire-box having a fuel-magazine located above it, with suitable provisions for admitting air from the bottom or sides, or both, or from the top through air-ducts around or through the magazine.

My invention consists, secondly, of a rectangular flue having its sides corrugated, so as to obtain the necessary strength, and the top and bottom of said flue being connected by a series of vertical tubes.

Thirdly, my invention consists in the combination of the vertical tubular furnace with the rectangular flue, traversed with tubes, and having its sides corrugated for strength.

The object of my invention is, first, a reconstruction of the present style of locomotive or fire-box boiler, having a more perfect combustion than the tubular boiler now and heretofore in use; secondly, its peculiar construction, making it practically a smoke-burning boiler, and when used for locomotives the combined arrangement of the vertical tubular grate and the flue traversed with vertical tubes, against which any coals which may be drawn from between the vertical tubular grate will necessarily be thrown, and the fire beaten out of them before being thrown into the open air, so that, in a measure, it is also a spark-arrester; and, third, is that the arrangement of the vertical tubular grates passing from the extra reservoir of water or additional water-space at the bottom of the fire-box and through the crown-sheet and the combined vertical tubes located in the rectangular flue guarantees a most perfect and even circulation of water throughout the boiler, and thereby obviates a serious difficulty common to the ordinary construction of tubular boilers—viz., priming or foaming, and in locomotive boilers

the raising of the water while working the engine, so that the water, as shown, is far from being solid, and the latter deception being undoubtedly the forerunner of numerous boiler-explosions.

Reference is made to the accompanying drawings.

Figure 1 represents a longitudinal vertical section of the boiler complete; Fig. 2, a horizontal section of the fire-box above the horizontal grate-bars on the line *x x* of Fig. 1, showing the enlarged water-space, the ends of the vertical tubes, and the horizontal grate-bars; Fig. 3, a cross-section of the cylindrical part of the boiler at *y y*; Fig. 4, a sectional plan of the longitudinal rectangular flue, showing its corrugated sides and the top ends of the vertical tubes forming the tubular grate, showing the ends of the tubes as they pass through the crown-sheet; Fig. 5, a section of the fire-box, showing a modified form of the enlarged water-space. Fig. 6 is a plan view of the fire-pot detached and the arrangement of the tubes forming it, taken on a line above the water-chamber, to which their lower ends are attached.

A represents the outside shell of a locomotive or fire-box boiler, of the usual shape. B represents the steam-space, as shown above the water line; C, the tubular fire box or grate, constructed of a series of vertical or inclined tubes, D, they in themselves forming a partly vertical or conical tubular grate connecting the crown-sheet of the fire-box with an internal enlarged water-space, E, which is joined to the outside or sheet fire-box or water-leg by small horizontal tubes *e*, or as shown in the modified form *E'*, Fig. 5.

Located over the fire-box, and passing through the shell of the boiler, is a magazine, F, fitted with a series of downward-draft tubes, *f*, and cover for same, *f'*. Inside of the vertical tubular grate is located a horizontal grate, G. A tapering throat connects the fire-box to a rectangular flue, H, leading to the smoke-box I. This rectangular flue is traversed by a series of vertical tubes, J, and its two vertical sides are formed and strengthened by corrugations L. The top and bottom sheets *h* are pierced for the tubes to pass through them.

There is provided at the fire-box end of the boiler an opening, N, through and connecting the inner and outer shell, and furnishing an aperture for observing the condition of the fire. This vertical or conical tubular fire-box or furnace may be of any desired size and shape, with or without an outside sheet or plate fire-box, so arranged that the vertical tubes shall act as a vertical or conical tubular grate and steam-generator.

The tubes may be set at an angle and inserted in the sides of outside sheet fire-box or water-leg, or with separate L or curved joint connections for each tube, or may be inserted in the top of the additional water-space or reservoir provided at the bottom of the fire-box or water-leg, as shown in Figs. 1 and 5 at E E', in the accompanying drawings, and may be in connection with a fuel-reservoir provided with downward air-tubes. The latter method is preferable, because it insures a larger body of water to provide for the rapid circulation necessarily caused by the intense heat that the tubes will be subjected to.

In addition to the vertical or conical tubular grate before specified, I use, in connection therewith, a horizontal grate-bar for supporting the fuel. This may be of any of the usual forms of grates, either stationary or movable. The latter, however, is preferable.

I so construct my fire-box with a fuel-magazine and downward-draft tubes as to permit as free a circulation of air to pass upon the outside of the vertical or conical tubular grates as may be required for perfect combustion of the gases by means of dampers of the usual form, and either by constructing the additional reservoir for water at the bottom of the fire-box, so as to permit of the air passing between it and the straight side sheets of the outside fire-box, as shown, or by sufficiently raising the horizontal grate-bars as to permit the necessary air-passage between them and the additional water-reservoir; or it may be admitted directly from the outside through tubes, or through divisions in the additional water-reservoir, or through the horizontal grate-bars. This arrangement for admitting air by means of the vertical or conical tubular grate causes the cold air to pass over so much heated surface that it practically prevents the admission of any cold air into the body of the boiler, and also permits of the delivery of air in such proportion and its proper place as to insure perfect combustion, and thereby practically produce a smokeless furnace and boiler.

Combined in producing the latter effect is the construction, in connection with this tubular fire-box, of a magazine for fuel, located over said fire-box, and provided with a series of downward draft-tubes, the bottom of this magazine having an enlarged or flaring mouth at its lower end for the better release of the fuel after the same has been expanded by the action of the heat, and its enlarged lower end so surrounded and protected by water by making an annular depression in the crown-sheet

running from a downward projection in the point to a point on a line with the back vertical tubes for the purpose of always insuring a sufficient quantity of water around the upper ends of the vertical tubes, and for the ready removal of any sediment or foreign matter that would otherwise settle there and concrete, the danger of which is well known to practical men; but I may not confine myself strictly to this construction, as the depression may run the entire width of the crown-sheet or otherwise, as may be determined by the formation of the boiler, so as to prevent the possibility of melting or burning the same; and, finally, after all the gases that have been generated from the green or fresh fuel have been compelled to pass over a live fire located between the vertical or conical tubular grates so as to create perfect combustion, I admit or draw the heat and flame into the continuous rectangular flue, having its sides corrugated for additional strength, as well as to give additional heating-surface, and the same being traversed by a series of vertical tubes for the purpose of creating additional heating-surface and insuring a perfect and even circulation of the water, and permitting the steam, as it is generated, to pass upward into the steam-space above the water-line.

This flue may be constructed of any desired dimensions, and the number of the corrugations are not necessarily limited; but I prefer to have a corrugation for every row of tubes, so as to permit of a tube being located in the extreme bend of the corrugation, and again utilize all the heating-surface by compelling the flame to impinge against the corrugated sides and envelop the tubes as much as possible. The corrugated sides and top of this rectangular flue may be slightly crowned, and thereby cause them to take the place of an arch-bar should additional strength be desired.

A small opening is constructed through the outside fire-box for the purpose of enabling the person in charge of the boiler to observe when the fuel requires replenishing.

A very important feature in the construction of my horizontal rectangular flue is, that the stay-bolts permanently attaching it to the shell of the boiler may be dispensed with, permitting its ready removal therefrom for repairs, &c.; but the stay-bolts may be used, if desired.

Having described my invention, what I claim is—

1. In a horizontal boiler, the combination, with the fire-box thereof, of an inner fire-pot, consisting of upright water-tubes D, the front and rear tubes inclining toward each other at the top, and the side tubes nearly vertical, and provided at its upper end with a chute, the whole forming a fuel-magazine and grate, substantially as shown and described.

2. The combination of a fire-pot consisting of vertical and inclined water-tubes, connected at the bottom to a water-chamber and at the top to a depressed water-chamber, which forms

part of the crown-sheet, the lower chamber being in communication with the water-leg of the boiler, and the upper chamber forming a water-projection for the tubes, substantially as shown and described.

3. In a horizontal boiler, the fire-pot made of water-tubes, inclined as shown, and forming a fuel-magazine, in combination with the fuel-chute F, provided with air-inlets at the top and a flaring bottom, the latter being protected by the water in chamber o, constructed and arranged as shown and described.

4. A horizontal boiler provided with an inner fire-pot and grate composed of water-tubes, inwardly inclined and running from the crown-sheet to a water-chamber located below the horizontal grate, and so connected to the water-leg of the boiler that the air may pass freely between the chamber and water-leg, and also a free and rapid circulation be given to the water between said water-leg and crown-sheet.

5. The combination of a fire-pot and fuel-magazine, made of water-tubes, inclined as shown, and a horizontal grate, all located within the fire-box of a boiler, arranged in such manner that an annular V-shaped chamber is formed in the fire-box for the admission of air and the commingling therewith of the products of combustion, substantially as herein described.

6. The combination, in a horizontal boiler, of a fire-box and a rectangular flue, constructed with corrugated vertical sides, the top and bottom water-spaces of the boiler being connected by water-tubes running through said flue, the corrugations being so arranged as each to admit a tube, whereby the products of combustion are made to take a tortuous course, substantially as described.

7. The combination, in a horizontal boiler, of a fire-box provided with a tubular fire-pot, a rectangular flue extending through the cylindrical portion of the boiler, said flue having vertical corrugated sides, and its top and bottom connected by vertical tubes, said fire-box and flue being connected by a tapering throat, in the manner set forth and described.

8. A horizontal boiler having a vertical tubular grate provided with a magazine over the fire-box of said boiler, its enlarged lower end arranged below the water-line, and thereby protected by a free circulation of water, and said magazine being provided with a series of downward tubes for admission of air and for creating a more perfect combustion of the gases, substantially as specified.

FREDERIC C. WEIR.

Witnesses:

CHAS. C. ABBE,
E. R. WILLIAMS.