



- (51) International Patent Classification:  
*H01F 7/02* (2006.01)    *E05B 47/00* (2006.01)
- (21) International Application Number:  
PCT/EP2013/062948
- (22) International Filing Date:  
20 June 2013 (20.06.2013)
- (25) Filing Language:  
English
- (26) Publication Language:  
English
- (30) Priority Data:
 

1210900.5	20 June 2012 (20.06.2012)	GB
1216514.8	16 September 2012 (16.09.2012)	GB
1222144.6	10 December 2012 (10.12.2012)	GB
1300638.2	14 January 2013 (14.01.2013)	GB
1300555.8	14 January 2013 (14.01.2013)	GB
1300551.7	14 January 2013 (14.01.2013)	GB
1306870.5	16 April 2013 (16.04.2013)	GB
1309452.9	26 May 2013 (26.05.2013)	GB

(81) Designated States (unless otherwise indicated, for every kind of national protection available): AE, AG, AL, AM, AO, AT, AU, AZ, BA, BB, BG, BH, BN, BR, BW, BY, BZ, CA, CH, CL, CN, CO, CR, CU, CZ, DE, DK, DM, DO, DZ, EC, EE, EG, ES, FI, GB, GD, GE, GH, GM, GT, HN, HR, HU, ID, IL, IN, IS, JP, KE, KG, KN, KP, KR, KZ, LA, LC, LK, LR, LS, LT, LU, LY, MA, MD, ME, MG, MK, MN, MW, MX, MY, MZ, NA, NG, NI, NO, NZ, OM, PA, PE, PG, PH, PL, PT, QA, RO, RS, RU, RW, SC, SD, SE, SG, SK, SL, SM, ST, SV, SY, TH, TJ, TM, TN, TR, TT, TZ, UA, UG, US, UZ, VC, VN, ZA, ZM, ZW.

(84) Designated States (unless otherwise indicated, for every kind of regional protection available): ARIPO (BW, GH, GM, KE, LR, LS, MW, MZ, NA, RW, SD, SL, SZ, TZ, UG, ZM, ZW), Eurasian (AM, AZ, BY, KG, KZ, RU, TJ, TM), European (AL, AT, BE, BG, CH, CY, CZ, DE, DK, EE, ES, FI, FR, GB, GR, HR, HU, IE, IS, IT, LT, LU, LV, MC, MK, MT, NL, NO, PL, PT, RO, RS, SE, SI, SK, SM, TR), OAPI (BF, BJ, CF, CG, CI, CM, GA, GN, GQ, GW, KM, ML, MR, NE, SN, TD, TG).

- (71) Applicant: INELXIA LIMITED [GB/GB]; 52 Hermitage Road, Abingdon, Oxfordshire OX14 5RW (GB).
- (72) Inventor: CHAIZY, Patrick André; 52 Hermitage Road, Abingdon Oxfordshire OX14 5RW (GB).
- (74) Agent: LIND, Robert; c/o Marks & Clerk LLP, Fletcher House (2nd Floor), Heatley Road, Oxford Science Park, Oxford Oxfordshire OX4 4GE (GB).

Published:  
— with international search report (Art. 21(3))  
— before the expiration of the time limit for amending the claims and to be republished in the event of receipt of amendments (Rule 48.2(h))

[Continued on next page]

(54) Title: MAGNETIC FIXINGS AND CONNECTORS

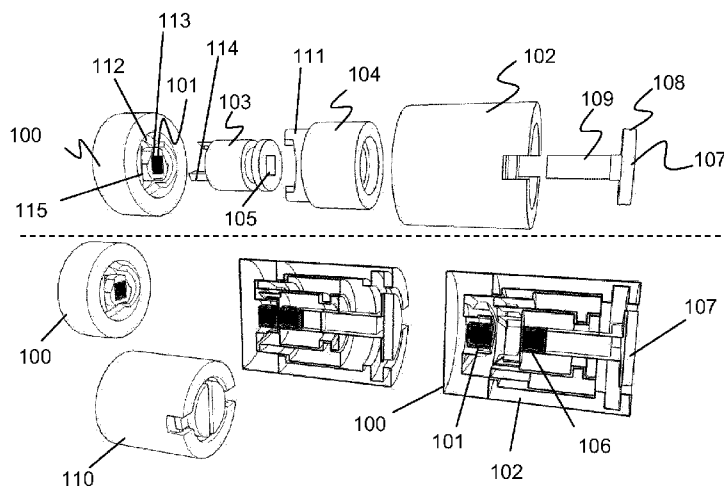

Figure 39

(57) Abstract: A mechanism comprising a first component (24) having a first magnetic part, a second component (23), and a third component (25) having a second magnetic part, the third component (25) being moveable relative to said first component (24) in a given direction to effect connection and or disconnection of the first and second components by causing interaction of the first and second magnetic parts, wherein, when connected, the first and second components are able to move relative to one another in said given direction. The mechanism further comprising a fourth component (26) for engagement with said first component (24) to prevent movement of the third component (25) relative to the first component (24) as a result of relative movement of the first and second components, thereby to prevent unintended disconnection of the first and second components.



**(88)** Date of publication of the international search report:  
20 February 2014

INTERNATIONAL SEARCH REPORT

International application No  
PCT/EP2013/062948

A. CLASSIFICATION OF SUBJECT MATTER  
INV. H01F7/02 E05B47/00  
ADD.  
According to International Patent Classification (IPC) or to both national classification and IPC

B. FIELDS SEARCHED  
Minimum documentation searched (classification system followed by classification symbols)  
H01F E05B  
Documentation searched other than minimum documentation to the extent that such documents are included in the fields searched

Electronic data base consulted during the international search (name of data base and, where practicable, search terms used)  
EPO-Internal, WPI Data

C. DOCUMENTS CONSIDERED TO BE RELEVANT

Category*	Citation of document, with indication, where appropriate, of the relevant passages	Relevant to claim No.
X	DE 10 2007 058188 A1 (FIDLOCK GMBH [DE]) 10 June 2009 (2009-06-10) cited in the application paragraphs [0024] - [0033]; figures 11-15 figures 1-14	1,2,6, 10,11, 20-22
A	----- US 2010/308605 A1 (FIEDLER JOACHIM [DE]) 9 December 2010 (2010-12-09) figures 1,9,10,11	1
X,P	----- WO 2012/160195 A2 (CHAIZY PATRICK ANDRE [GB]) 29 November 2012 (2012-11-29) cited in the application pages 4,5; figure 6 ----- -/--	1

Further documents are listed in the continuation of Box C.

See patent family annex.

\* Special categories of cited documents :

- "A" document defining the general state of the art which is not considered to be of particular relevance
- "E" earlier application or patent but published on or after the international filing date
- "L" document which may throw doubts on priority claim(s) or which is cited to establish the publication date of another citation or other special reason (as specified)
- "O" document referring to an oral disclosure, use, exhibition or other means
- "P" document published prior to the international filing date but later than the priority date claimed

- "T" later document published after the international filing date or priority date and not in conflict with the application but cited to understand the principle or theory underlying the invention
- "X" document of particular relevance; the claimed invention cannot be considered novel or cannot be considered to involve an inventive step when the document is taken alone
- "Y" document of particular relevance; the claimed invention cannot be considered to involve an inventive step when the document is combined with one or more other such documents, such combination being obvious to a person skilled in the art
- "&" document member of the same patent family

Date of the actual completion of the international search  10 October 2013	Date of mailing of the international search report  08/01/2014
Name and mailing address of the ISA/ European Patent Office, P.B. 5818 Patentlaan 2 NL - 2280 HV Rijswijk Tel. (+31-70) 340-2040, Fax: (+31-70) 340-3016	Authorized officer  Weisser, Wolfgang

## INTERNATIONAL SEARCH REPORT

International application No  
PCT/EP2013/062948

C(Continuation). DOCUMENTS CONSIDERED TO BE RELEVANT		
Category*	Citation of document, with indication, where appropriate, of the relevant passages	Relevant to claim No.
A	US 3 596 958 A (BOWERMAN WILLIAM R) 3 August 1971 (1971-08-03) cited in the application the whole document	1
A	----- DE 145 325 C (RICHARD DOLGE) 25 November 1903 (1903-11-25) cited in the application the whole document -----	1

# INTERNATIONAL SEARCH REPORT

International application No.  
PCT/EP2013/062948

## Box No. II Observations where certain claims were found unsearchable (Continuation of item 2 of first sheet)

This international search report has not been established in respect of certain claims under Article 17(2)(a) for the following reasons:

1.  Claims Nos.:  
because they relate to subject matter not required to be searched by this Authority, namely:
  
2.  Claims Nos.:  
because they relate to parts of the international application that do not comply with the prescribed requirements to such an extent that no meaningful international search can be carried out, specifically:
  
3.  Claims Nos.:  
because they are dependent claims and are not drafted in accordance with the second and third sentences of Rule 6.4(a).

## Box No. III Observations where unity of invention is lacking (Continuation of item 3 of first sheet)

This International Searching Authority found multiple inventions in this international application, as follows:

see additional sheet

1.  As all required additional search fees were timely paid by the applicant, this international search report covers all searchable claims.
  
2.  As all searchable claims could be searched without effort justifying an additional fees, this Authority did not invite payment of additional fees.
  
3.  As only some of the required additional search fees were timely paid by the applicant, this international search report covers only those claims for which fees were paid, specifically claims Nos.:
  
4.  No required additional search fees were timely paid by the applicant. Consequently, this international search report is restricted to the invention first mentioned in the claims; it is covered by claims Nos.:

1-22

### Remark on Protest

- The additional search fees were accompanied by the applicant's protest and, where applicable, the payment of a protest fee.
- The additional search fees were accompanied by the applicant's protest but the applicable protest fee was not paid within the time limit specified in the invitation.
- No protest accompanied the payment of additional search fees.

**FURTHER INFORMATION CONTINUED FROM PCT/ISA/ 210**

This International Searching Authority found multiple (groups of) inventions in this international application, as follows:

1. claims: 1-22

Mechanism (claims 1-20) of connecting a first component and a second component with each other, comprising the first component, having a first magnetic part (magnet), the second component, having a second magnetic part (magnet), and a third component. The third component is movable relative to said first component in a given direction to effect connection and/or disconnection of the first and second components by causing interaction of the first and second magnetic parts, wherein, when connected, the first and second components are able to move relative to one another in said given direction. The fourth component is for engagement with said first component to prevent movement of the third component relative to the first component as a result of relative movement of the first and second components, thereby to prevent unintended disconnection of the first and second components. Mechanism (claims 1-20) of connecting a first component and a second component with each other, comprising the first component, having a first magnetic part (magnet), the second component, having a second magnetic part (magnet), and a third component. The third component is movable relative to said first component in a given direction to effect connection and/or disconnection of the first and second components by causing interaction of the first and second magnetic parts, wherein, when connected, the first and second components are able to move relative to one another in said given direction. The fourth component is for engagement with said first component to prevent movement of the third component relative to the first component as a result of relative movement of the first and second components, thereby to prevent unintended disconnection of the first and second components. Apparatus (claims 21, 22) comprising said mechanism. Thereby, the fourth part decouples the second part from the third part. Rotation of the second part has no effect on the third part and in particular will not cause any rotation, and therefore release of, the third part from the first part (cf. page 4, line 12-14).

---

2. claims: 23-32

Kit of parts (claims 23-30) comprising first and second components configured to allow mechanical connection of the components together by relative motion in a given direction such that the first and second components are unable to move relative to one another in one or more directions but are free to move in one or more other directions, the kit of parts further comprising a third, locking component having fixed thereto a magnetic part, the third

## FURTHER INFORMATION CONTINUED FROM PCT/ISA/ 210

component being configured to be engaged with the first and second components whereby said magnetic part interacts with amagnetic part on one or both of the first and second components in order to prevent relative movement of the first and second components in the or at least one of said other directions.

Apparatus (claims 31, 32) comprising said kit of parts.

---

## 3. claims: 33-36

Mechanism (claims 33, 34) comprising first and second components configured to allow mechanical connection and disconnection of the components together by relative sliding of the components in a first linear direction, the first and second component each comprising magnetic parts at least one of which is movable within or around a guide in a second direction substantially perpendicular to said first linear direction, under the influence of the other magnetic part, in order to secure together and or release the first and second components, wherein in the secured state separation in a third linear direction substantially perpendicular to said first and second linear directions is prevented.

Apparatus (claims 35, 36) comprising said mechanism.

---

## 4. claims: 37-45

Mechanism (claims 37-43) comprising first and second components configured to allow mechanical connection and disconnection of the second component to the first component in a plurality of different locations on the first component, each location being defined by a respective first guide in the first component;  
and a third, locking component having a magnetic part for interacting with a magnetic part on the second component to cause movement of one of the magnetic parts into one of said first guides in order to secure the second and third parts relative to the first part.

Apparatus (claims 44, 45) comprising said mechanism.

---

## 5. claims: 46-53

Mechanism (claims 46-49) comprising first and second components configured to allow mechanical connection of the components together by relative motion of the components in a first linear direction to form a joint, whereby, when connected, the components cannot be separated in a second linear direction substantially perpendicular to said first linear direction;

and first and second collar parts locatable about the first and second components respectively, the first and second collar part each being provided with a magnetic part configured such that relative rotation of the collar parts,

## FURTHER INFORMATION CONTINUED FROM PCT/ISA/ 210

about the joint, causes the magnetic parts to interact and lock the collar parts about the joint, thereby preventing relative movement of the first and second components in said first linear direction.

Apparatus (claims 50, 51) comprising said mechanism.

Structure (claims 52, 53) using said mechanism.

---

## 6. claims: 54-58

Mechanism (claims 54, 55) comprising first and second components each comprising a plurality of magnetic parts, the magnetic parts being configured such that, when pairs of opposed magnetic parts on the first and second components are moved into and out of alignment by relative movement of the first and second components in a first linear direction, one of the magnetic parts of each pair is caused to move within or around a guide formed in the associated component into a guide formed in the other component, at least one of the pairs being configured to move a magnetic part in a second linear direction, substantially perpendicular to said first linear direction, to prevent separation of the components in a third linear direction substantially perpendicular to said first and second linear directions, and at least one of the pairs being configured to move a magnetic part in said third linear direction to prevent separation of the components in said second linear direction.

Apparatus (claims 56-58) comprising said mechanism.

---

## 7. claims: 59-62

Mechanism (claims 59-61) for attaching a rod at both ends to a supporting frame, the mechanism comprising, for each end of the rod

a fixing part for connection to the frame or to the end of the rod such that the part is slidable in the axial direction of the rod but is not rotatable with respect to the frame or rod to which it is to be connected;

a first magnetic part connected to the fixing part; and  
a second magnetic part for connection to the other of the frame or the rod to which the fixing part is not to be connected, the first and second magnetic parts being configured such that, in use, rotation of the rod with respect to the frame causes interaction of the magnetic components, sliding the fixing part into and or out of engagement with the other of the frame or the rod to which the fixing part is not to be connected.

Mechanism (claim 62) for attaching a rod at both ends to a supporting frame, the mechanism comprising, for each end of the rod;

a fixing part for connection to the frame or to the end of the rod such that the part is slidable in the axial direction of the rod;

## FURTHER INFORMATION CONTINUED FROM PCT/ISA/ 210

a first magnetic part connected to the fixing part; and a second magnetic part for connection to the other of the frame or the rod to which the fixing part is not to be connected, the first and second magnetic parts being configured such that, in use, rotation of the rod with respect to the frame in a given direction causing interaction of the magnetic components, sliding the fixing part into or out of engagement with the other of the frame or the rod to which the fixing part is not to be connected, rotation in the opposite direction causing a mechanical interaction to reverse the engagement or disengagement.

---

## 8. claims: 63-65

Apparatus comprising a first component and a second component mounted to the first component, the apparatus further comprising a mechanism for releasably securing the first component to the second component such that, when secured, the second component is prevented from moving in and out with respect to the first component and, when unsecured, the second component is able to move in and out with respect to the first component along at least one track formed in or on the first component, the mechanism comprising a first magnetic part coupled to the first component and a second magnetic part coupled to the second component, these parts being configured such that rotation or sliding of the second component with respect to the first component causes an interaction of the magnetic parts to move the second component between the secured and the unsecured positions.

---

## 9. claims: 66-68

Mechanism (claim 66) comprising a first component ; a second component ; complementary features provided on the first and second components to allow engagement of the two components by relative sliding of the components in a first linear direction; first and second magnetic parts configured to interact such that relative movement of the two magnetic parts in a second linear direction prevents or allows sliding movement of the two components in said first linear direction.  
Apparatus (claims 67, 68) comprising said mechanism.

---

## 10. claims: 69, 70

Mechanism (claim 69) comprising a first component comprising a first magnetic part ; a second component for coupling to the first component such that the second component is able to move freely with respect to the first component in a given direction;

**FURTHER INFORMATION CONTINUED FROM PCT/ISA/ 210**

a third component for coupling the first and second components together, the third component comprising a second magnetic part , movable with respect to the first magnetic part such that the interaction of the two magnetic parts couples and or uncouples the first and second components;  
and  
inter-engaging mechanical features on the first and third components which cooperate to prevent relative movement of the first and third components in said given direction in order to prevent disengagement of the first and second components.  
Hinge (claim 70) comprising said mechanism.

---

# INTERNATIONAL SEARCH REPORT

Information on patent family members

International application No

PCT/EP2013/062948

Patent document cited in search report	Publication date	Patent family member(s)	Publication date
DE 102007058188 A1	10-06-2009	CN 101939801 A	05-01-2011
		DE 102007058188 A1	10-06-2009
		EP 2218083 A2	18-08-2010
		US 2011001025 A1	06-01-2011
		WO 2009071071 A2	11-06-2009
-----			
US 2010308605 A1	09-12-2010	CN 101925313 A	22-12-2010
		EP 2252176 A2	24-11-2010
		US 2010308605 A1	09-12-2010
		WO 2009092368 A2	30-07-2009
-----			
WO 2012160195 A2	29-11-2012	NONE	
-----			
US 3596958 A	03-08-1971	NONE	
-----			
DE 145325 C	25-11-1903	NONE	
-----			