



INTERNATIONAL APPLICATION PUBLISHED UNDER THE PATENT COOPERATION TREATY (PCT)

<p>(51) International Patent Classification ⁵ : A61B 17/11</p>	<p>A1</p>	<p>(11) International Publication Number: WO 91/02491 (43) International Publication Date: 7 March 1991 (07.03.91)</p>
<p>(21) International Application Number: PCT/DK89/00197 (22) International Filing Date: 24 August 1989 (24.08.89) (71)(72) Applicant and Inventor: JØRGENSEN, Lars, Stig [DK/DK]; Engvangen 12, DK-8520 Lystrup (DK). (74) Agent: LEHMANN & REE; Frederiksberg Allé 26, DK-1820 Frederiksberg C (DK). (81) Designated States: AT (European patent), AU, BE (European patent), CH (European patent), DE (European patent)*, DK, FI, FR (European patent), GB (European patent), IT (European patent), JP, LU (European patent), NL (European patent), NO, SE (European patent), US.</p>		<p>Published <i>With international search report.</i> <i>In English translation (filed in Danish).</i></p>

(54) Title: INSTRUMENT AND METHOD FOR COLON AND RECTUM RESECTION

(57) Abstract

An instrument for colon and rectum resection and a subsequent anastomosis permits an aseptic and easy operation. The instrument comprises a diathermy snare (1) supported on a rigid support snare (3) which makes it possible to perform a precise location of the diathermy snare (1). The instrument has an extraction wire (8) provided with a circular end section (9) having a diameter smaller than the diameter of the possible opening of the support and diathermy snare (3, 1). The support snare is introduced via two guides (4) in a tubular connection means (6) which is also connected to the extraction wire (8). The instrument is introduced via anus to the diseased intestine section (19). The end section (9) is displaced through the support and diathermy snare and the intestine is fixed hereto whereafter an invagination is performed. The intestine is sutured without being opened whereafter the support snare is removed and the diathermy snare (1) is constricted around the intestine and the latter is cut off. The invaginated intestine may hereafter be extracted via anus together with the instrument. Thus, the intestine has not been opened during the operation.

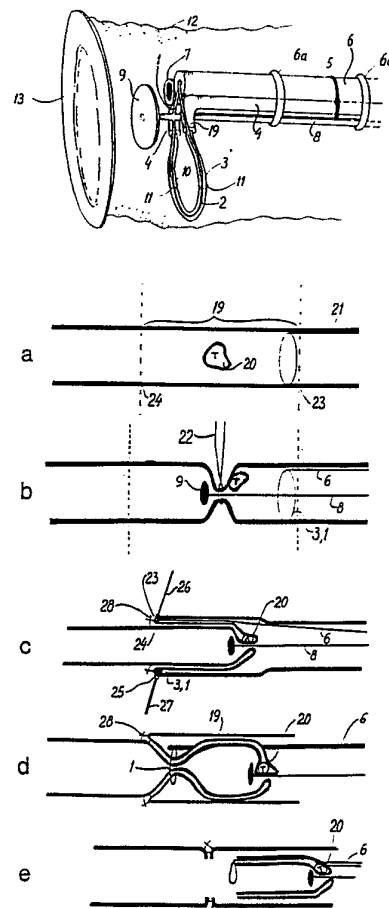

DESIGNATIONS OF "DE"

Until further notice, any designation of "DE" in any international application whose international filing date is prior to October 3, 1990, shall have effect in the territory of the Federal Republic of Germany with the exception of the territory of the former German Democratic Republic.

FOR THE PURPOSES OF INFORMATION ONLY

Codes used to identify States party to the PCT on the front pages of pamphlets publishing international applications under the PCT.

AT	Austria	ES	Spain	MC	Monaco
AU	Australia	FI	Finland	MG	Madagascar
BB	Barbados	FR	France	ML	Mali
BE	Belgium	GA	Gabon	MR	Mauritania
BF	Burkina Fasso	GB	United Kingdom	MW	Malawi
BG	Bulgaria	GR	Greece	NL	Netherlands
BJ	Benin	HU	Hungary	NO	Norway
BR	Brazil	IT	Italy	PL	Poland
CA	Canada	JP	Japan	RO	Romania
CF	Central African Republic	KP	Democratic People's Republic of Korea	SD	Sudan
CG	Congo			SE	Sweden
CH	Switzerland	KR	Republic of Korea	SN	Senegal
CM	Cameroon	LI	Liechtenstein	SU	Soviet Union
DE	Germany	LK	Sri Lanka	TD	Chad
DK	Denmark	LU	Luxembourg	TG	Togo
				US	United States of America

INSTRUMENT AND METHOD FOR COLON AND RECTUM RESECTIONBACKGROUND OF THE INVENTION

5 The present invention relates to an instrument for colon and rectum resection and a method wherein such a resection is performed by use of the instrument.

10 Colon and rectum resections are relatively often performed on surgical wards. The operation is most often performed on grounds of cancer, but also on grounds of other conditions as e.g. diverticulum disease and inflammatory intestinal diseases, colitis ulceration and Crohn's disease. Today colon resection is performed by division of the intestine after it has been dissected free of peritoneum and mesenterium. Thereafter the intestine continuity is reestablished by anastomizing the two open ends in one or two layers. This may take place either by conventional hand suturation or by special instruments (autosuture instruments). Contamination from the opened intestine involves a risk of infection (wound infection, intraperitoneal absces, peritonitis, septicæmi) as colon is heavily colonized with bacteria. It has been attempted to limit the infection risk through a reduction of the quantity of faeces in the intestine by some form of mechanical cleansing, by antibiotic pretreatment of the intestine and/or by preoperative or peroperative systemic antibiotic profylaxis. By conventional pretreatment without antibiotic profylaxis there is a substantial risk of some form of infection in connection with colon resection. Anastomosis leakage is another significant complication and it is believed that infection influences such a leakage.

25 Different forms of autosuture instruments have been developed which permit the application of the anastomosis to be much quicker than conventional hand suturation. However, these instruments are not aseptic and they are also expensive in use. Therefore it is desirable to be able to use an aseptic method and to use instruments which are inexpensive and which also enable easy succeeding conventional anastomosis.

35 Different instruments for surgical operation in tubular organs such as intestines and veins are known. These instruments are for example intended for performing a cutting-off or for suturing, or the instruments may be used as auxiliary equipment with a view to reducing the risk of infection or to facilitate the work of the surgeon. Thus, e.g.

clamps to close the intestine ends until most of the anastomosis has been sutured and autosuture instruments permitting a quicker anastomosis are known. Examples of surgical apparatus are known from, e.g. US patents Nos. 3,472,231, 4,328,805, 4,503,855, 3,771,526 and 3,935,981 and FR-A-2,619,301, SE patent No. 356,896 and DE patent No. 2,513,868. The instrument known from SE patent No. 356,896 is intended for proctologic operations. This apparatus comprises grasping and extracting means which may extract a diseased mucosa from the lower part of rectum. After the extraction, external cutting means are used to remove the diseased mucosa. This instrument will provide some of the desirable advantages, but the instrument has a limited field of application and it is also complicated to handle.

However, none of the instruments known from these patents make it possible to perform resection including succeeding anastomosis in a quick manner and without opening the intestinal wall at some time.

It is the object of the present invention to provide an instrument for colon and rectum resection including succeeding anastomosis which apparatus is arranged to make it possible to perform an aseptic operation, as the operation may take place from the internal side of the intestine without opening the intestine, and so that a support of the intestine is formed whereby the suture place is presented tubular and inverted so as to facilitate the suturing.

This object is achieved with an instrument for colon and rectum resection and comprising cutting means and extraction means, characterized in that the cutting means are provided in the form of a diathermal cutting snare and a support snare supporting the diathermy snare, that the diathermy snare, the support snare and the extraction means are arranged to be introduced via anus, and to be activated via a flexible tubular connection means and by means of operating means in a handle outside the body, that the support snare is introduced via two guides in the tubular connection means and is so arranged that it can be released from the diathermy snare and thus be extracted through one of the guides, that the extraction means are constituted of a thin, but rigid wire connected to the tubular connection means and having a circular end section with a diameter smaller than the diameter of the optional opening of the support snare and the diathermy snare support-

ed thereon, and
that a plate or the like is so arranged that it can be fixed relative
to the extraction wire in a position outside the body.

5 The instrument according to the invention is introduced via anus with-
out opening the intestine. The end section of the extraction wire is
placed immediately in front of the support snare and the diathermy
snare supported thereon, and this unit is introduced through the in-
10 testine approximately to the place of the distal resection line. Here
the support and diathermy snare are opened so that they press gently
against the intestinal wall. The end section of the extraction wire is
pushed through the support snare and the diathermy snare supported
thereon and forwards to approximately the middle of the intestine sec-
15 tion to be removed. Because of the rigidity and the diameter of the
support snare, the surgeon will be able to place the instrument cor-
rectly in a quick and easy way from the outside. After the end section
of the extraction wire has been placed correctly, it is fixed to the
intestine from the outside, e.g. with a ligature. By the operating
20 means, the surgeon is hereafter able to invaginate the diseased intes-
tine section through the support snare and the diathermy snare and
down into the healthy intestine. The support snare is located at the
fold which results from the invagination. When the invagination is
completed and the two places on the intestine to be anastomosed have
25 met, the instrument is fixed from the outside by means of the plate
bearing against anus. Hereby the invaginated intestine will not be
able to slip back. After the support snare and the diathermy snare
have been closed slightly, the surgeon may easily suture along the
fold as the suture place is presented as tubular and inverted. The
30 anastomosis may optionally be applied with autosuture instruments or
by conventional hand suturation. After the suturation, the support
snare is extracted and the diathermy snare is tightened and an attached
traditional diathermy apparatus is activated whereby the invaginate is
burnt through and released from the intestine. It may hereafter be
35 extracted through anus together with the instrument. The operation has
taken place from the inside of the intestine which has at no time been
opened thereby reducing the risk of infection considerably. The instru-
ment may hereafter be prepared for reuse. Certain parts of the instru-
ment may be exchangeable without affecting the instrument costs essen-
tially.

As the instrument permits an operation from the inside of the intestine, the risk of infection is reduced and hereby the need for use of antibiotics is reduced as well. Thus the instrument permits a cost-saving operation and at the same time it reduces the risk of antibiotic-associated complications.

The instrument may advantageously be wrapped in a sterile bag having a glue edge which is attached around anus. This bag may confine only a part of the instrument and may terminate immediately before the operation means so that a surgeon may easily adjust them.

As it will appear from the above, the known methods for colon and rectum resection are associated with drawbacks that are primarily related to the infection risk. Thus even known so-called aseptic methods have proved not to be aseptic in practice. The contamination with visceral contents was limited only by closing the intestine ends with suture or clamps until the major part of the anastomosis had been sutured. Apart from the introduction of prophylactic antibiotic treatment, methods for colon and rectum resection not involving a risk of infection have thus not been described recently. However, the increasing rise of broad-spectrum antibiotics is neither cheap nor without problems. Thus the risk of developing resistance and of antibiotic-associated complications (the development of allergy, anaphylactic reactions, antibiotic-associated colitis) is increased.

In acute operations, especially in the left side of colon (particularly contaminated) it is common practice today to perform a temporary colostomy. This is due to the fact that contamination from the non-pretreated intestine involves a substantial risk of complications if the intestine ends are joined primarily. Not until an operation is performed some months later, the colostomy is healed and the intestine ends are joined. Of course, this temporary colostomy causes inconvenience to the patient. Furthermore, two operations are to be performed which increases the patient's risk of complications and in addition, takes up resources. Capacity-wise and from a social point of view, it is desirable to finish the treatment of the patient rapidly and by performing only one surgical operation.

Examples of the known technology within the field may include the ope-

ration methods described in US Patents Nos. 3,472,231, 4,328,805, 3,771,526, and 4,705,040. However, none of the operation methods described in these patents point out satisfactorily a method to be used for colon and rectum resection and reducing the infection risk.

5

Thus it is a further object of the invention to provide a method for colūm and rectum resection which is aseptic and reduces the risk of infection. This method permits the operation to be performed rapidly and safely even in case of acute operations where the intestine is poorly evacuated.

10

This object is achieved by a method according to the invention wherein an instrument according to the invention is used and wherein the section of intestine to be removed in a usual manner is identified and released from peritoneum and mesentarium which method is characterized in that,

15

prior to the release of the intestine section the instrument is introduced via anus,

20

that the instrument with the diathermy and support snares closed around the end section of the extraction wire is introduced approximately to the place of the distal resection line, as the surgeon has a visual indication of the position of the support snare from the outside of the intestine and as the surgeon controls the introduction of the instrument through the intestinal wall,

25

that the end section of the extraction wire is displaced further forwards through the support snare and the cutting snare to a position shortly beyond the centre of the intestine section to be removed,

30

that the intestine is fixed to the extraction wire with a ligature or the like behind the end section of the extraction wire, that the support snare and the diathermy snare supported thereon are opened by means of a handle so that the snares exert a gentle pressure onto the intestinal wall,

35

that the intestine section to be removed is then led down into the healthy intestine by invagination until the two sites on the intestine to be anastomosed are joined as the invaginate is led down through the support snare and the diathermy snare,

that the support snare and the diathermy snare are tightened slightly so as not to press against the intestinal wall,

that the extraction wire is fixed by means of the external plate relative to the patient as the invaginated intestine section is kept in press,

5 that the intestine is sutured with soluble ligature all the way round, that the support snare is removed by extraction through the one of its guides in the tubular means,

that the diathermy snare is tightened and activated with cutting current whereby the invaginate is burnt through and released from the intestine,

10 that the invaginate is extracted through anus along with the instrument, and

that the wound in the abdominal wall is closed in a conventional manner.

15 In the described method, the intestine is not opened in connection with the division. The division takes place inside the intestine only after the diseased part of the intestine has been invaginated down into the healthy intestine and after the intestine has been sutured. Thus an aseptic resection is achieved by the method whereby the risk
20 of infection deriving from the contamination from the open intestine is substantially avoided. Hereby it becomes possible to perform the operation with a substantially reduced need for antibiotics thereby reducing costs associated with the operation and at the same time the risk of antibiotic-associated problems is reduced. The resection may
25 also be performed quickly and safely as the invagination ensures that the suture place is presented as tubular and inverted. Hereby it becomes possible to perform a quick and simple suture. This may be performed by means of autosuture instruments or by conventional hand suture.

30 Furthermore, the described method may very advantageously be used in case of acute operations. As there are no risk of complications associated with joining the intestine ends by the method according to the invention it will not be necessary to perform a temporary colostomy to
35 be reperformed after a couple of months. Thus this method will cause less inconvenience to the patient. In addition, this yields further capacity and social advantages as only one operation is required in order to finish the treatment of the patient.

Furthermore, the method may be used when treating cancer diseases where tissue as for example mesenterium and omentum is to be removed together with the intestine. Generally, these appendices have to be removed in advance in order to facilitate the invagination. This may be done
5 quickly and simply with a pair of scissors as the blood supply is cut off after the dissection.

If the method is used in an acute operation where faeces are not evacuated from the intestine, the described method may advantageously be
10 combined with a lavement, using an instrument comprising a suction and flushing passage.

Depending on the length and the flexibility of the tubular connection means of the instrument the method may be used for resection of the
15 small intestine in the same way as by colon resection.

If an invagination is prevented for example because of a large tumour, an alternative method may be used as referred to in claim 8. By this alternative method an aseptic operation is achieved together with the
20 advantages associated with the above-described method. However, the alternative method will be slightly slower as a constriction and a removal of the part of the intestine which cannot be invaginated has to take place initially.

25 DESCRIPTION OF THE DRAWINGS

The invention will now be further explained with reference to the accompanying drawing, wherein

- Fig. 1 illustrates a partial view of a detail of an instrument according to the invention,
30 Fig. 2 illustrates a partial view of another detail of the instrument,
Fig. 3 illustrates a partial view of a further detail of the instrument,
Fig. 4 illustrates a method according to the invention, and
35 Fig. 5 illustrates an alternative method according to the invention.

Together Figures 1,2, and 3 illustrate an instrument according to the invention. It is noted that the illustrated elements are partly dis-

torted by way of illustration.

Fig. 1 shows the front end of the instrument, i.e. that part which is intended to be conducted into the intestine via anus. Fig. 2 illustrates that part of the instrument which is intended to be outside the body and Fig. 3 illustrates the operation means of the element which also are outside the body. The instrument comprises a diathermy snare 1. The diathermy snare 1 is only uninsulated over a short distance 2. Hereby the cutting effect is concentrated and when used for cutting off an intestine section, the thread will not give rise to unsuitable heating of a larger area which would otherwise possibly have involved that cells denature. The diathermy snare is supported by a support snare 3 constituted of a flexible relatively rigid element, e.g. a wire formed of spiral thread. The element runs through two guides 4 forming the support snare at the front end of the instrument. The guides 4 and a protection casing 5 for the diathermy snare are placed in a flexible tubular connection means 6. The tubular connection means 6 also comprises a passage 7 for injection of protection gas, preferably CO₂. An injection with CO₂ eliminates the risk of explosions when the diathermy thread is activated with a cutting current. The tubular connection means also supports the extraction means in form of a thin, but rigid wire 8 having a circular end section 9. The diameter of the circular end section 9 is smaller than the optional opening 10 for the support snare 3 and the diathermy snare 1 supported thereon. The wire 8 is optionally connected to the tubular connection means 6 by means of an elastic connection, e.g. of one or more rubber bands 6a which allow a displacement of the wire 8.

The diathermy snare 1 and the support snare 3 are mutually connected by means of loops 11. Only two are shown, but also two or more loops 11 may be used. The loops 11 make it possible to release the connection between the two snares so that the support snare 3 may be extracted through one of the guides 4.

Fig. 1 illustrates a sterile bag 12 which encases the instrument and is provided with a glue edge 13 intended for application around anus. The sterile bag 12 may encase the entire instrument including the handle part 14 as illustrated in Fig. 3. However, this bag may also be arranged to end before the handle 14 so that the latter may be ope-

rated in a more easy way. Fig. 2 illustrates a plate 15 intended to bear against anus. The plate 15 is provided with clamping means (not shown) making it possible to perform a mutual fitting of the extraction wire 8 and the plate 15. The importance of this will be explained later on.

The handle 14 establishes a mutual connection between the diathermy snare 1 and the support snare wire 3. The connection is releasable as the diathermy snare thread 1 is connected to a clamping device 16 and the support snare wire 3 is connected to a clip 17 at each end. Thus it is possible to release the support snare wire 3 from the clips 17 whereby the support snare wire may be extracted through the one guide 4 when the diathermy snare is in its place. When the support snare and the diathermy snare are clamped in the clamping device 16 and in the clips 17, respectively, they will accompany each other when the handle 14 is operated. Fig. 3 also shows that the extraction wire 8 is provided with a grip 18 which may be activated independently of the handle 14.

Fig. 1 shows that the ends 19 of the guides 4 are orientated substantially perpendicular to the tubular connection means 6. Hereby the orientation substantially perpendicular to the tubular connection means is imparted to the support snare and may thereby be visually followed when it is conducted through the intestine as a surgeon with the hand may conduct the support snare 3 with the diathermy snare 1 supported thereon to the correct position for these elements.

The length of the tubular connection means 6 may vary from approx. 30 cm to approx. 150 cm depending on where in the intestine the instrument is intended to be used in the intestine. Furthermore, the passage 7 of the instrument may be used as a suction and flushing passage which may be an advantage in acute operations as hereby it becomes possible to evacuate the intestine. Furthermore, the instrument may be provided with a thermometer (not shown) measuring the temperature in the area at the uninsulated part 2 of the diathermy thread. The thermometer may be connected to guide means (not shown) interrupting the cutting current when there is a risk of denaturation of cells.

In order to make it possible to remove as short a length of the intes-

tine as possible, it is advantageous that the end section 9 of the extraction wire is disc-shaped as shown in Fig. 1. This is especially the case when the instrument is used during rectum resection.

5 The apparatus according to the invention may be used by a method according to the invention for colon and rectum resection and which is explained in the following with reference to Figs. 4 and 5.

10 Fig. 4 illustrates a method wherein an intestine section 19 contains a tumour 20. The tumour 20 is so small that it is possible to invaginate the diseased intestine section 19 into the healthy intestine section 21. After the intestine section 19 has been identified the instrument is introduced via anus with the support snare 3 and the diathermy snare 1 supported thereon tightened completely around the end section 9 of the extraction wire. Preferably this takes place before the operation starts as the sterile bag 12 may be pulled over the instrument and glued around anus before a skin disinfection and a sterile covering of the patient are performed. Hereafter the intestine section 19 is laid free in the usual manner. The relatively rigid support snare gives the surgeon a visual indication of the position of the snares. The two sites 23,24 on the intestine to be anastomosed are located and the snares are introduced approximately to the distal resection line 23. Hereafter, the snares 1,3 are opened by means of the handle 14 and the end section 9 of the extraction wire is displaced through the support snare and the cutting snare 3,1 to a position shortly beyond the middle of the intestine section 19 (Fig. 4b). The intestine is constricted behind the end section 9 by means of a sewing thread 22. Hereafter the intestine section 19 may be invaginated into the healthy intestine 21 until the two sites 23,24 on the intestine to be anastomosed meet (Fig. 4c). The intestine section 19 is invaginated through the support snare 3 and the cutting snare 1 which has been pressed upwards against the fold 25 formed by the invagination. After the invagination, the snares are easily closed and the intestine is tubular and inverted because of the position of the invagination. In order to make the diameter of the anastomosis as wide as possible, holding sutures 26,27 are pulled mesenterically and antimesenterically (Fig. 4c). Simultaneously, the invaginated intestine section is held under tension as the plate 15 is locked relative to the tubular means 6 and thus in relation to the extraction wire 8 in a position where the extraction wire is

15
20
25
30
35

drawn backwards. Thereafter the intestine is sutured with soluble ligature 28 all the way around. Hereafter the support snare 3 is extracted through one of its guides 4 and the diathermy snare 1 is tightened (Fig. 4d) whereafter the cutting current is activated. Hereby the intestine section 19 is released from the remaining part of the intestine and may thereafter be extracted (Fig. 4e) through anus together with the instrument. Hereafter the wound in the abdominal wall may be closed in the usual manner. By this method, the intestine has not been opened at any time and the risk of infection is thereby avoided. Hereby the use of antibiotics is considerably reduced which also reduces the risk of resistance development and of antibiotic-associated complications. The instrument proper is relatively inexpensive to produce as it consists of simple elements which may be reused. Furthermore, the use of the instrument is inexpensive and effective as the surgeon needs only one operation to finish the treatment of the patient.

An alternative method for using the instrument according to the invention is illustrated in Fig. 5. This method is used when the tumour 20 found is so large that the invagination is impossible. Firstly, the tumour is identified (Fig. 5a) in the usual manner. Hereafter, the instrument is introduced via anus whereafter the sterile bag 12 may be pulled over the instrument and glued around anus. Before the instrument is introduced into the intestine to its final position, a constriction of the intestine is performed (5c). The constriction is performed by means of two pair of clips 29 applied immediately adjacent to each other on each side of the tumour 20. Hereafter the intestine is divided by cutting 30 between each of the two pairs of clips 29 and the intestine section 31 containing the tumour is removed. Hereafter the end section 9 of the extraction wire is pushed forward to come into contact with the distal constricted end of the intestine. Afterwards a constriction of the distal intestine end behind the end section 9 is performed by means of a thread 32. Before the subsequent invagination, the two intestine ends are connected either by means of the thread 32 or by means of coupling means on the two clips 29.

35

In the following steps, the same method is followed as explained above with reference to Fig. 4. Thus an invagination (Fig. 5e) is performed followed by a suturing (Fig. 5f). Thereafter the support snare wire 3 is extracted and the diathermy snare is constricted (Fig. 5g). Hereby

the invaginate is released from the remaining part of the intestine and may be extracted (Fig. 5h) through anus together with the instrument. Subsequently, the wound in the abdominal wall is sutured in the usual manner. By this method the same advantages as described above are achieved as the intestine has not been opened. By use of this method the two closed intestine ends joined together by clips may optionally be dipped in iodine immediately after the cutting of the intestine.

10 In tests performed with the instrument according to the invention and with both of the methods described, i.e. a poor and a good intestine evacuation, good results are achieved. Thus in the anastomosis and in the operation wound less than 100 bacteria have been observed and the operation has proceeded without complications.

15

20

25

30

35

CLAIMS:

1. Instrument for colon and rectum resection and comprising cutting means and extraction means, c h a r a c t e r i z e d in that the cutting means are provided in the form of a diathermal cutting snare and a support snare supporting the diathermy snare, that the diathermy snare, the support snare and the extraction means are arranged to be introduced via anus, and to be activated via a flexible tubular connection means and by means of operating/or means in a handle outside the body, that the support snare is introduced via two guides in the tubular connection means and is so arranged that it can be released from the diathermy snare and thus be extracted through one of the guides, that the extraction means are constituted of a thin, but rigid wire connected to the tubular connection means and having a circular end section with a diameter smaller than the diameter of the optional opening of the support snare and the diathermy snare supported thereon, and that a plate or the like is so arranged that it can be fixed relative to the extraction wire in a position outside the body.
2. Instrument according to claim 1, c h a r a c t e r i z e d in that the circular end section is disc-shaped.
3. Instrument according to claim 1 or 2, c h a r a c t e r i z e d in that the insulation of the diathermy snare is removed from a relatively short section only.
4. Instrument according to any one of the preceding claims, c h a r a c t e r i z e d in that diathermy snare is connected to the support snare by means of several loops each having such a size that the support snare may pass freely therethrough during the extraction procedure and that the operating means comprises a releasable connection device enabling simultaneous movement of the support snare and the diathermy snare in an interlocked condition and which, in a released condition, releases the support snare for the separate extraction thereof.
5. Instrument according to any one of the preceding claims, c h a r a c t e r i z e d in that the support snare passes through guides in the tubular connection means and that the mouth of the guides is

orientated so that the support snare is substantially perpendicular to the tubular connection means.

5 6. Instrument according to any one of the preceding claims, characterized in that the tubular means comprises passages for further auxiliary equipment, e.g. a common passage for injection of protection gas and for suction and flushing of the intestine or the like.

10 7. Method for colon and rectum resection by use of an instrument according to any one of the preceding claims and wherein the section of the intestine to be removed is identified in the usual manner and released from peritoneum and mesenterium, characterized in that prior to the release of the intestine section the instrument is
15 introduced via anus,
that the instrument with the diathermy and support snares closed around the end section of the extraction wire is introduced approximately to the place of the distal resection line, as the surgeon has a visual indication of the position of the support snare from the outside of
20 the intestine and as the surgeon controls the introduction of the instrument through the intestinal wall,
that the end section of the extraction wire is displaced further forwards through the support snare and the cutting snare to a position shortly beyond the centre of the intestine section to be removed,
25 that the intestine is fixed to the extraction wire (8) with a ligature or the like behind the end section of the extraction wire,
that the support snare and the diathermy snare supported thereon are opened by means of a handle so that the snares exert a gentle pressure onto the intestinal wall,
30 that the intestine section to be removed is then led down into the healthy intestine by invagination until the two sites on the intestine to be anastomosed are joined as the invaginate is led down the support snare and the diathermy snare,
that the support snare and the diathermy snare are tightened slightly
35 so as not to press against the intestinal wall,
that the extraction wire is fixed by means of the external plate relative to the patient as the invaginated intestine section is kept in press,
that the intestine is sutured with soluble ligature all the way round,

that the support snare is removed by extraction through the one of its guides in the tubular means,

5 that the diathermy snare is tightened and activated with cutting current whereby the invaginate is burnt through and released from the intestine,

that the invaginate is extracted through anus along with the instrument, and

that the wound in the abdominal wall is closed in a conventional manner.

10

8. Method according to claim 7 and wherein the invagination is made impossible, e.g. due to a large tumour, characterized in that a method prior to the introduction of the instrument into its final position comprises,

15 that the part of the intestine to be removed is constricted by a pair of clips or the like placed immediately adjacent to each other on each side of the tumour,

that the intestine is divided by cutting between the clips in each of the two pairs, and

20 that the method after the introduction of the instrument into its final position comprises,

that the end section of the extraction wire is displaced to come into contact with the distal constricted intestine end,

25 that the two intestine ends closed by clips are fixed to each other, and

that the intestine ends are fixed to the extraction wire as a thread is constricted behind the end section of the extraction wire, whereupon the invagination and the subsequent steps are performed.

30 9. Method according to claim 8, characterized in that the two clips remaining on the intestine ends are coupled by interlocking coupling means on the two clips.

35 10. Method according to any one of claims 7 to 9, characterized in that diameter of the anastomosis during the suturing is made as large as possible by pulling the holding sutures mesenterically and antimesenterically.

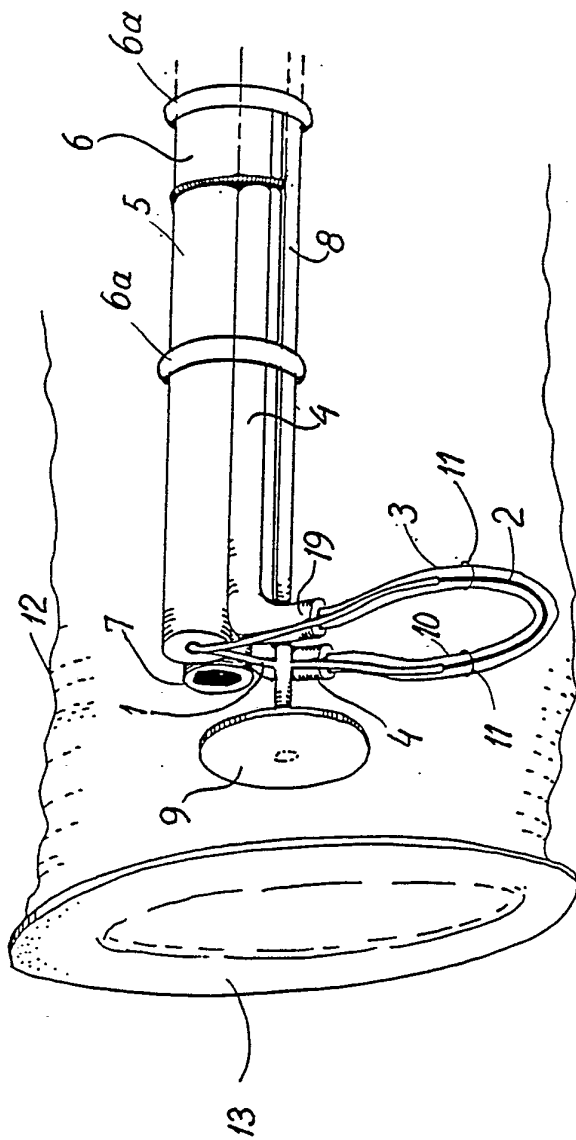

Fig. 1

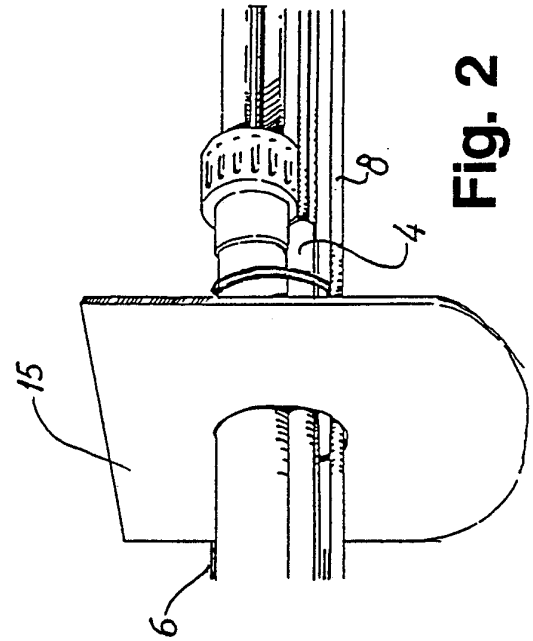

Fig. 2

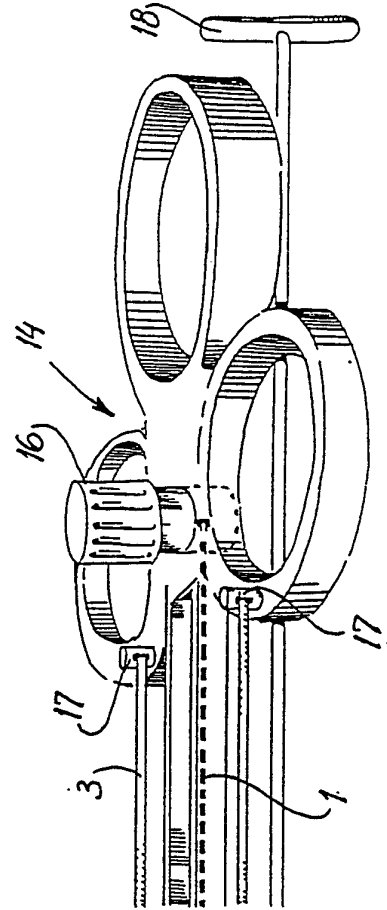

Fig. 3

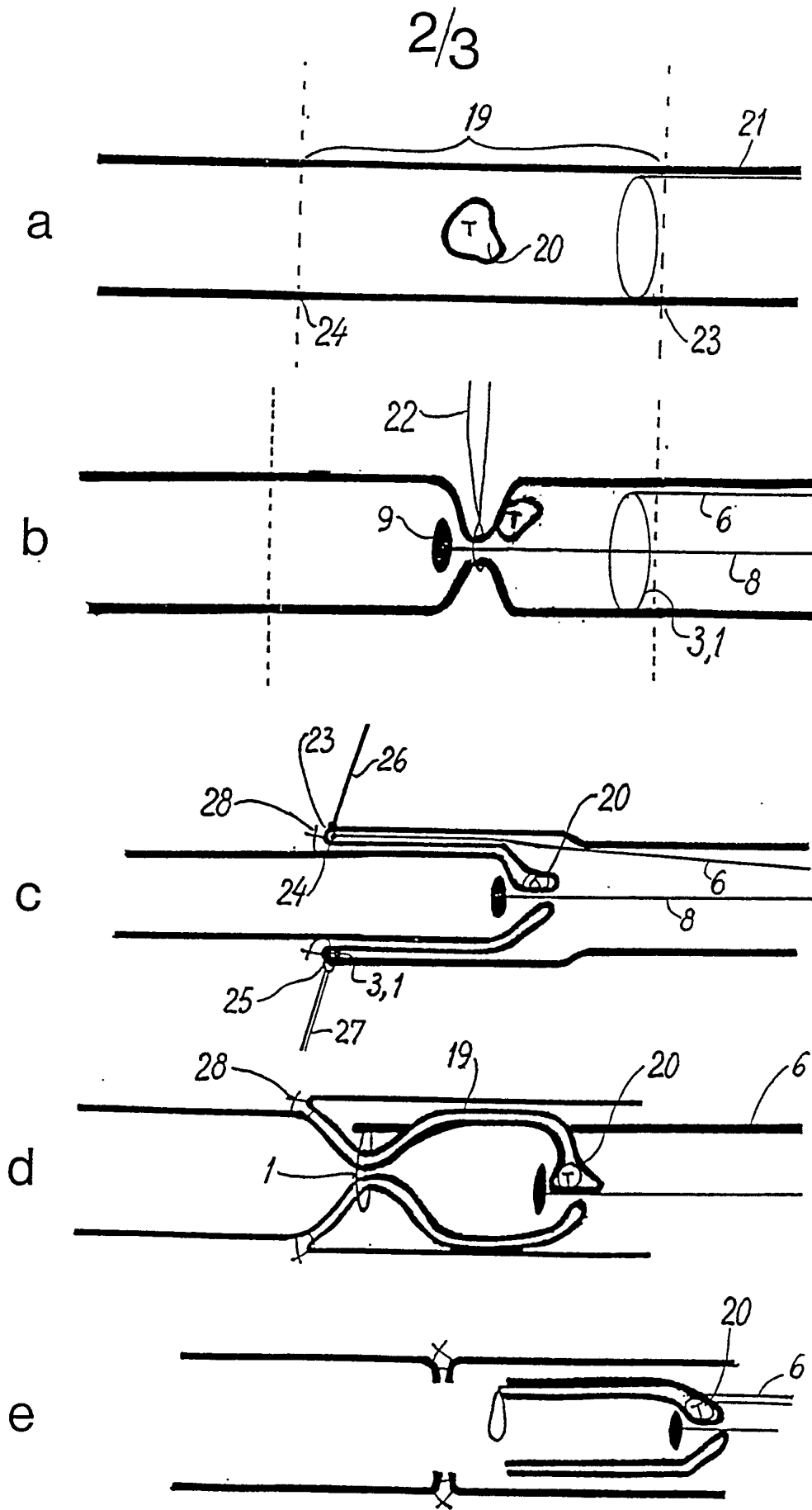

Fig. 4

3/3

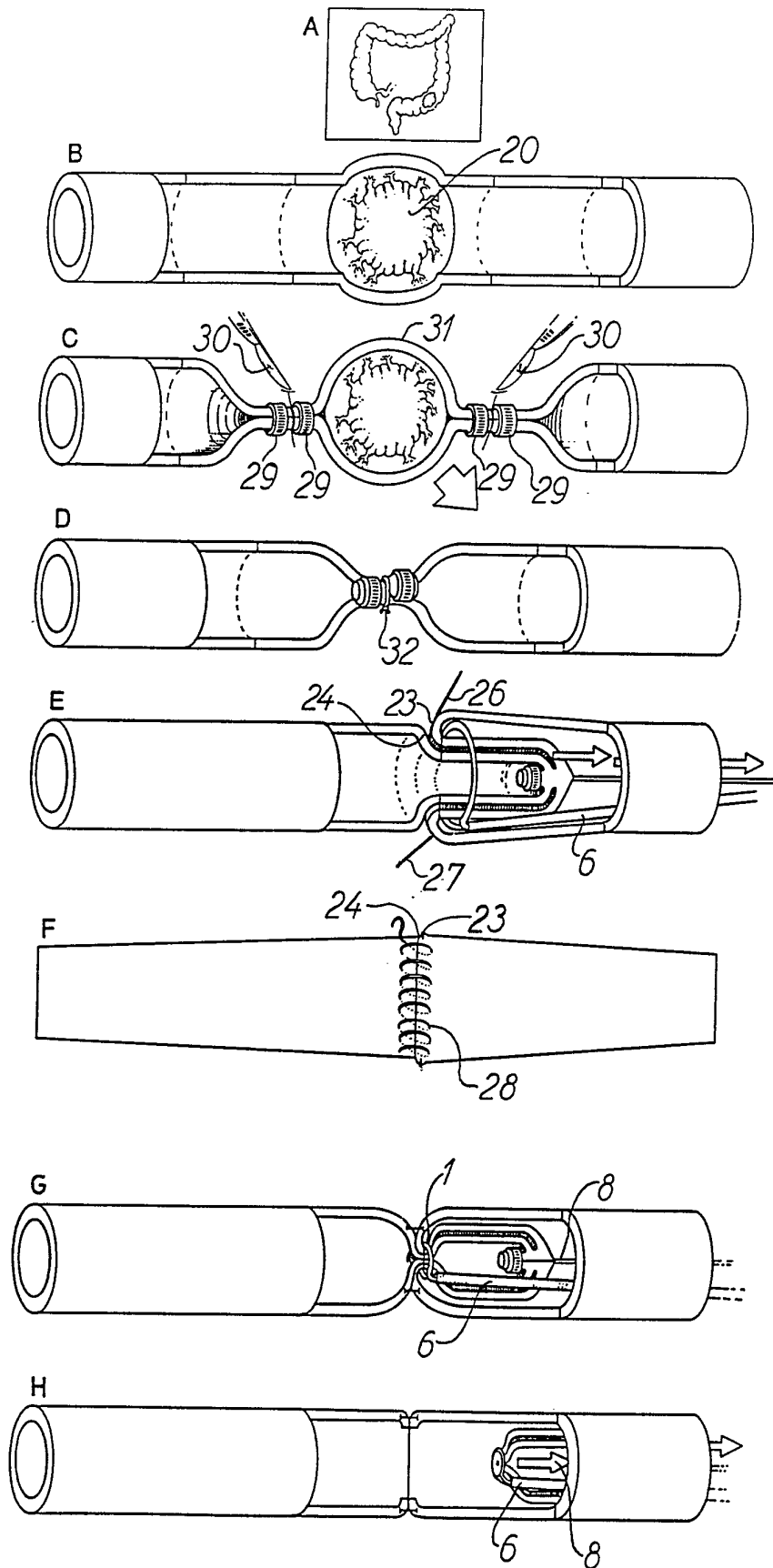
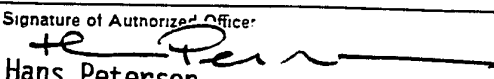

Fig. 5

INTERNATIONAL SEARCH REPORT

International Application No PCT/DK 89/00197

I. CLASSIFICATION OF SUBJECT MATTER (if several classification symbols apply, indicate all) *		
According to International Patent Classification (IPC) or to both National Classification and IPC		
IPC5: A 61 B 17/11		
II. FIELDS SEARCHED		
Minimum Documentation Searched †		
Classification System	Classification Symbols	
IPC5	A 61 B	
Documentation Searched other than Minimum Documentation to the Extent that such Documents are Included in the Fields Searched ‡		
SE,DK,FI,NO classes as above		
III. DOCUMENTS CONSIDERED TO BE RELEVANT †		
Category *	Citation of Document, †† with indication, where appropriate, of the relevant passages †††	Relevant to Claim No. ††††
A	Derwent's abstract, No. 87-361 074/51, SU 1 309 972, publ. week 8751 (TOPUZOV), see figures 1-5 --	1-6
A	FR, A1, 2619301 (MONARQUE) 17 February 1989, see abstract; figures 1-4 --	1-6
A	SE, B, 356896 (TJONG-JOE-WAI) 12 June 1973, see figures 1-8 see claims --	1-6
A	US, A, 3771526 (RUDIE) 13 November 1973, see abstract; figures 1-12 --	1-6
<p>* Special categories of cited documents: ††</p> <p>"A" document defining the general state of the art which is not considered to be of particular relevance</p> <p>"E" earlier document but published on or after the international filing date</p> <p>"L" document which may throw doubts on priority claim(s) or which is cited to establish the publication date of another citation or other special reason (as specified)</p> <p>"O" document referring to an oral disclosure, use, exhibition or other means</p> <p>"P" document published prior to the international filing date but later than the priority date claimed</p> <p>"T" later document published after the international filing date or priority date and not in conflict with the application but cited to understand the principle or theory underlying the invention</p> <p>"X" document of particular relevance: the claimed invention cannot be considered novel or cannot be considered to involve an inventive step</p> <p>"Y" document of particular relevance: the claimed invention cannot be considered to involve an inventive step when the document is combined with one or more other such documents, such combination being obvious to a person skilled in the art</p> <p>"Z" document member of the same patent family</p>		
IV. CERTIFICATION		
Date of the Actual Completion of the International Search	Date of Mailing of this International Search Report	
26th March 1990	1990 -03- 29	
International Searching Authority	Signature of Authorized Officer:	
SWEDISH PATENT OFFICE	 Hans Peterson	

III. DOCUMENTS CONSIDERED TO BE RELEVANT (CONTINUED FROM THE SECOND SHEET)		
Category*	Citation of Document, with indication, where appropriate, of the relevant passages	Relevant to Claim No
A	US, A, 4503855 (MASLANKA) 12 March 1985, see abstract; figure 1 -- -----	1-6

FURTHER INFORMATION CONTINUED FROM THE SECOND SHEET

V. OBSERVATIONS WHERE CERTAIN CLAIMS WERE FOUND UNSEARCHABLE ¹

This International search report has not been established in respect of certain claims under Article 17(2) (a) for the following reasons:

1. Claim numbers 7-10, because they relate to subject matter not required to be searched by this Authority, namely:

Methods for treatment of the human or animal body by surgery or therapy. (PCT, Article 17(2)(a)(i), Rule 39(iv))

2. Claim numbers, because they relate to parts of the international application that do not comply with the prescribed requirements to such an extent that no meaningful international search can be carried out, specifically:

3. Claim numbers, because they are dependent claims and are not drafted in accordance with the second and third sentences of PCT Rule 6.4(a).

VI. OBSERVATIONS WHERE UNITY OF INVENTION IS LACKING ²

This International Searching Authority found multiple inventions in this international application as follows:

1. As all required additional search fees were timely paid by the applicant, this international search report covers all searchable claims of the international application.
2. As only some of the required additional search fees were timely paid by the applicant, this international search report covers only those claims of the international application for which fees were paid, specifically claims:
3. No required additional search fees were timely paid by the applicant. Consequently, this international search report is restricted to the invention first mentioned in the claims; it is covered by claim numbers:
4. As all searchable claims could be searched without effort justifying an additional fee, the international Searching Authority did not invite payment of any additional fee.

Remark on Protest

- The additional search fees were accompanied by applicant's protest.
- No protest accompanied the payment of additional search fees.

**ANNEX TO THE INTERNATIONAL SEARCH REPORT
ON INTERNATIONAL PATENT APPLICATION NO. PCT/DK 89/00197**

This annex lists the patent family members relating to the patent documents cited in the above-mentioned international search report.

Patent document cited in search report	Publication date	Patent family member(s)	Publication date
FR-A1- 2619301	89-02-17	NONE	
SE-B- 356896	73-06-12	BE-A- 754628	71-01-18
		DE-A- 2037504	71-02-25
		FR-A- 2056817	71-05-14
		GB-A- 1312306	73-04-04
		NL-A- 7011762	71-02-15
		US-A- 3564582	71-02-16
US-A- 3771526	73-11-13	NONE	
US-A- 4503855	85-03-12	DE-A-C- 3247793	83-07-14
		DE-C- 3249452	85-12-19