

(19) **DANMARK**

(10) **DK/EP 2771085 T3**



(12) **Oversættelse af  
europæisk patentskrift**

Patent- og  
Varemærkestyrelsen

- 
- (51) Int.Cl.: **B 01 J 19/00 (2006.01)** **B 01 D 3/32 (2006.01)**
- (45) Oversættelsen bekendtgjort den: **2019-04-23**
- (80) Dato for Den Europæiske Patentmyndigheds bekendtgørelse om meddelelse af patentet: **2019-01-16**
- (86) Europæisk ansøgning nr.: **12843562.5**
- (86) Europæisk indleveringsdag: **2012-09-07**
- (87) Den europæiske ansøgnings publiceringsdag: **2014-09-03**
- (86) International ansøgning nr.: **US2012054065**
- (87) Internationalt publikationsnr.: **WO2013062677**
- (30) Prioritet: **2011-10-27 US 201113283400**
- (84) Designerede stater: **AL AT BE BG CH CY CZ DE DK EE ES FI FR GB GR HR HU IE IS IT LI LT LU LV MC MK MT NL NO PL PT RO RS SE SI SK SM TR**
- (73) Patenthaver: **UOP LLC, 25 East Algonquin Road , P.O. Box 5017, Des Plaines, Illinois 60017-5017, USA**
- (72) Opfinder: **NAUNHEIMER, Christopher, UOP LLC, 25 East Algonquin Road, P.O. Box 5017, Des Plaines, Illinois 60017-5017, USA**  
**SATTAR, Aziz, UOP LLC, 25 East Algonquin Road, P.O. Box 5017, Des Plaines, Illinois 60017-5017, USA**
- (74) Fuldmægtig i Danmark: **RWS Group, Europa House, Chiltern Park, Chiltern Hill, Chalfont St Peter, Bucks SL9 9FG, Storbritannien**
- (54) Benævnelse: **KLINKE TIL EN HYDROBEHANDLINGSBEHOLDER OG TILHØRENDE FREMGANGSMÅDE**
- (56) Fremdragne publikationer:  
**DE-A1- 2 109 889**  
**FR-A- 1 260 797**  
**RU-C1- 2 146 548**  
**RU-C2- 2 172 203**  
**RU-C2- 2 241 515**  
**RU-C2- 2 430 285**  
**SU-A- 203 621**  
**US-A- 3 649 466**  
**US-A1- 2002 131 841**  
**US-A1- 2010 018 012**



# DESCRIPTION

## PRIORITY CLAIM OF EARLIER NATIONAL APPLICATION

## FIELD OF THE INVENTION

**[0001]** This invention generally relates to a latch for a hydroprocessing vessel and a method relating thereto.

## DESCRIPTION OF THE RELATED ART

**[0002]** Often vessels, such as reactors, adsorbers, strippers, and distillation columns, utilize trays for gas-liquid contacting in various operations, such as hydroprocessing. The trays can be installed during initial construction of the vessel, as well as removed and reinstalled during maintenance or refurbishing. Various fasteners may be used securing a tray to a support ring positioned along an internal circumference of the vessel. Such fasteners may include one or more bolts, nuts, and/or J-shaped clamps.

**[0003]** However, such fasteners can suffer several disadvantages. Particularly, often a tray may have various tubes, such as downcomers, extending through the tray. As a result, the available space may be limited. As an example, a slotted screwdriver and a wrench are typically used to orientate and secure a J-clip to a tray. Often, space is limited interfering with the ability to rotate the wrench inside of the vessel. Due to the space limitations, the fastening of the J-clip to a support ring for securing the tray can be a time consuming process.

**[0004]** US 2010/0018012 describes a clamp for securing a tray in a vessel. Accordingly, it is desirable to provide an alternative fastening mechanism that can be used within a space constrained area and may minimize the number of tools required to secure a tray to a vessel.

## SUMMARY OF THE INVENTION

**[0005]** In the first aspect, there is provided a hydroprocessing vessel as defined in claim 1.

**[0006]** In the second aspect, there is provided a method of latching a member to an internal structure of a hydroprocessing vessel as defined in claim 2.

**[0007]** Usually, the hydroprocessing vessel includes an enclosure defining an interior volume, at least one internal structure, a member, and a latch having an elongated substantially

cylindrical shaft coupled to a helical pawl for engaging and disengaging the member from the at least one internal structure.

**[0008]** A further exemplary embodiment may be a method of latching a member to an internal structure of a hydroprocessing vessel. The method can include coupling a helical pawl of a latch to the internal structure. Typically, the helical pawl has a first position disengaged with the internal structure and a second position engaged with the internal structure.

**[0009]** The latch allows the simple fastening of a tray to a vessel. Generally, the latch can include a helical or spiral pawl for securing the tray to the vessel. A protrusion on an end can be adapted to correspond with a tool, such as an extension for a ball-and-socket wrench to allow rotation of the latch within constrained spaces of a vessel to secure or release the tray by engaging or disengaging the latch.

## **DEFINITIONS**

**[0010]** As used herein, the term "coupled" can mean two items, directly or indirectly, joined, fastened, associated, connected, or formed integrally together either by chemical or mechanical means, by processes including stamping, molding, or welding. What is more, two items can be coupled by the use of a third component such as a mechanical fastener, e.g., a screw, a nail, a staple, or a rivet; an adhesive; or a solder.

**[0011]** As used herein, the terms "absorbent" and "absorber" include, respectively, an adsorbent and an adsorber, and relates, but is not limited to, absorption, and/or adsorption.

**[0012]** As used herein, the term "vapor" can mean a gas or a dispersion that may include or consist of one or more hydrocarbons.

## **BRIEF DESCRIPTION OF THE DRAWINGS**

### **[0013]**

FIG. 1 is a cross-sectional, schematic depiction of a portion of an exemplary vessel.

FIG. 2 is a top, plan view of an exemplary platform in the exemplary vessel.

FIG. 3 is a perspective view of an exemplary latch.

FIG. 4 is a side, elevational view of the exemplary latch.

FIG. 5 is another side, elevational view of the exemplary latch.

FIG. 6 is a back, elevational view of the exemplary latch of FIG. 5.

**DETAILED DESCRIPTION**

**[0014]** Referring to FIG. 1, an exemplary vessel 10 can be utilized in any suitable hydrocarbon refining process, such as hydroprocessing. Generally, the vessel 10 can be a reactor, an adsorber, a stripper, a distillation column, or any other suitable vessel utilized in, e.g., hydroprocessing operations. Often, such a vessel 10 can facilitate mass transfer operations in downflow, upflow, co-current flow, and counter-current flow for one or more fluids, such as a gas, a liquid, and/or a mixed phase of a gas and a liquid, such as a dispersion.

**[0015]** The vessel 10 can include an enclosure 20 having one or more side walls defining an interior volume 30. Often, at least one internal structure 40 can be located inside of the vessel 10. As depicted in FIG. 1, the at least one internal structure 40 can include beams 50, a support ring 54, and a member 70. In this exemplary embodiment, the member 70 can include a tray 80 having one or more downcomers 84. Often, gas can flow downward through the downcomers with liquid collecting on the tray 80. Although not depicted, apertures in the tray 80 can allow liquid to pass there-through. In addition, in some operations gas may pass upwards. Two latches 100 can secure the tray 70 to the support ring 54.

**[0016]** Referring to FIG. 2, a platform 60 is depicted positioned at another elevation within the vessel 10. The platform 60 is not depicted in FIG. 1 of the vessel 10. At this location, at least one internal structure 40 can include the platform 60 that can be positioned inside of the vessel 10 and be used instead or in conjunction with the tray 80 depicted in FIG. 1. In this exemplary embodiment, the platform 60 can be substantially circular forming a rectangular opening for positioning a member 70, in this instance a man-way cover 90 positioned over beams 50, therein. The man-way cover 90 can straddle beams 50 and be secured with the latches 100. As the latches 100 can be substantially similar, only one latch 100 will be described hereinafter with respect to the tray 80, although the latch 100 may also be similarly utilized with the man-way cover 90, as depicted in FIG. 2.

**[0017]** Referring to FIGS. 3-6, a latch 100 can include an elongated substantially cylindrical shaft 120 coupled to a helical or spiral pawl 140. In addition, a grip 160 can be coupled to the elongated substantially cylindrical shaft 120 on an upper end 150, and in turn, be coupled with a protrusion 170. The protrusion 170 can be substantially wedge-shaped, although the protrusion 170 can form any suitable shape. The grip 160 may form a polygon having at least three sides, and in this exemplary embodiment, have a perimeter substantially being a hexagon. Generally, the grip 160 can be adapted to be engaged by any suitable tool, such as a wrench, pliers, and an extension for a ball-and-socket wrench.

**[0018]** The helical pawl 140 can be used for engaging and disengaging a member, such as the tray 80, and may extend or at least partially spiral no more than 180 degrees, optionally no more than 120 degrees or 100 degrees, about the circumference of the elongated substantially

cylindrical shaft 120. Desirably, the helical pawl 140 has a rise of no more than 30 degrees from a lower end 144 to an upper end 148. This allows an upper face of the helical pawl 140 to slide up against the underside of the tray 80.

**[0019]** Referring to FIGS. 3-5, the latch 100 can form two pieces 110 and 112 corresponding at a seam 114 with each piece 110 and 112 inserted through a hole from opposing sides of the tray 80. The first piece 110 including the grip 160 and the protrusion 170 may be inserted downward through the hole and the second piece 112 including the elongated substantially cylindrical shaft 120 and the helical pawl 140 may be inserted upward through the hole. The first and second pieces can be coupled using any suitable connection, such as threads, press-fits, or welds, to form a unitary piece as depicted in FIGS. 4-6. The seam 114 may be obscured by the tray 80 in FIGS. 4-6. Generally, the grip 160 has a larger circumference than the hole to prevent the latch 100 from falling there-through.

**[0020]** The latch 100 can have a first position 104 disengaged from the tray 80, as depicted in FIG. 4, and a second position 108 engaged with the tray 80, as depicted in FIG. 5. Utilization of a hand or any suitable tool, such as an extension for a ball-and-socket wrench, can be applied to the grip 160 to rotate the latch 100, as depicted in FIG. 4, 180 degrees clockwise to position the helical pawl 140 underneath the support ring 54 of the vessel 100. Although in this exemplary embodiment the latch 100 is rotated 180 degrees, any suitable path of rotation may be utilized, such as 30 to 540 degrees, preferably 90 to 270 degrees. The protrusion 170 can indicate the position of the latch 100 by pointing away from the wall 20, as depicted in FIG. 5, when the upper end 148 of the pawl 140 engages the underside of the support ring 54.

**[0021]** As depicted in FIG. 6, the helical pawl 140 of the latch 100 can reside completely underneath the support ring 54. Optionally, a gasket 44, as shown in FIGS. 4-6, can be positioned between the tray 80 and the support ring 54 to allow some resiliency between the support ring 54 and the tray 80 to secure them thereto.

**[0022]** The latch 100 can be manufactured from any suitable material depending on the conditions within the vessel 10. Such suitable materials can include carbon steel, stainless steel, and titanium. The gasket 44 can be manufactured from any suitable material, such as rubber, synthetic plastic, or heat resistant fiber, such as one or more ceramic fibers.

**[0023]** Thus, the latch 100 allows the securing of the tray 80 within the vessel 10. Reversing the positioning of the latch 100 by 90 degrees as depicted in FIG. 4 can allow the removal of the tray from the vessel 100 for, e.g., maintenance or refurbishment. The protrusion 170 can indicate the disengaged position by pointing towards the wall 20. It should be understood that the protrusion 170 can be modified so pointing towards the wall 20 indicates engagement and pointing away from the wall indicates disengagement of the latch 100. In addition, the grip 160 being a polygon with at least three sides may correspond to a suitable tool, such as a wrench or pliers. Thus the installation of members, such as trays and man-way covers, inside a vessel can be hastened and thus time spent offline or during installation of the trays may be minimized. Moreover, such a latch can ease operation, and thus minimize potential injuries.

## REFERENCES CITED IN THE DESCRIPTION

This list of references cited by the applicant is for the reader's convenience only. It does not form part of the European patent document. Even though great care has been taken in compiling the references, errors or omissions cannot be excluded and the EPO disclaims all liability in this regard.

### Patent documents cited in the description

- US20100018012A [0004]

## Patentkrav

1. Hydrobehandlingsbeholder (10), der indeholder en indvendig struktur (40) og en klinke (100) til klinkelukning af en del til  
5 en indvendig struktur i beholderen, hvor klinken (100) omfatter:  
A) et aflangt i det væsentlige cylindrisk skaft (120);  
B) en spiralformet klinkehage (140), der er koblet til det aflange i det væsentlige cylindriske skaft; og  
C) et greb, der er koblet til det aflange i det væsentlige  
10 cylindriske skaft, hvor grebet danner en polygon med mindst tre sider og er indrettet til at gå i indgreb med et værktøj; hvor den spiralformede klinkehage ikke strækker sig mere end 180 grader omkring omkredsen af det aflange i det væsentlige cylindriske skaft; og  
15 hvor klinken er konfigureret, således at den spiralformede klinkehage har en første position (104), der er ude af indgreb med den indvendige struktur, og en anden position (108), der er i indgreb med den indvendige struktur.
- 20 2. Fremgangsmåde til klinkelukning af en del til en indvendig struktur (40) i hydrobehandlingsbeholderen (10) ifølge krav 1, som omfatter:  
kobling af en spiralformet klinkehage (140) af en klinke til den indvendige struktur (40), hvor den spiralformede klinkehage  
25 (140) har en første position (104), der er ude af indgreb med den indvendige struktur (40), og en anden position (108), der er i indgreb med den indvendige struktur (40).
3. Fremgangsmåde ifølge krav 2, hvor delen omfatter en bakke  
30 (80).
4. Fremgangsmåde ifølge krav 3, hvor bakken omfatter et eller flere nedløbsrør.
- 35 5. Fremgangsmåde ifølge krav 2 eller 3, hvor delen omfatter et mandehulsdæksel.
6. Fremgangsmåde ifølge krav 2, hvor grebet danner en

heksagon, der er indrettet til at gå i indgreb med en skruenøgle.

**DRAWINGS**

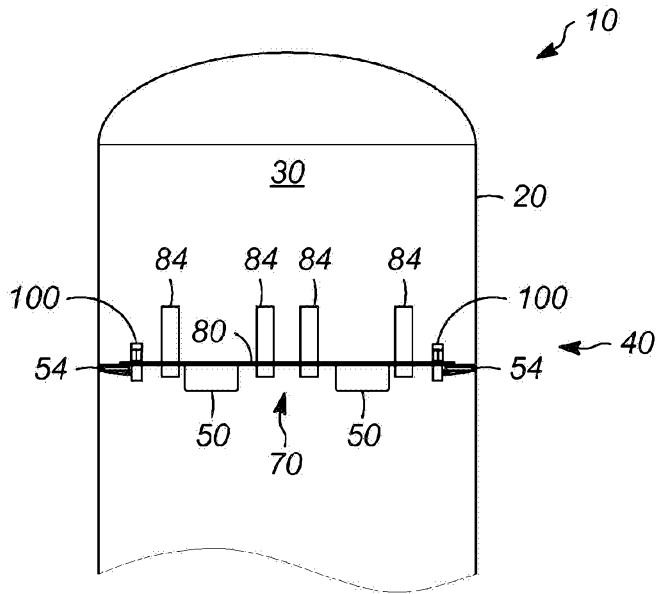

**FIG. 1**

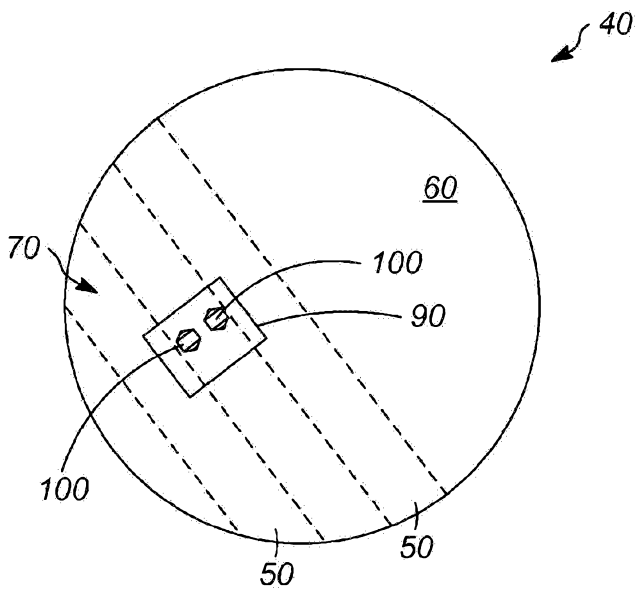

**FIG. 2**

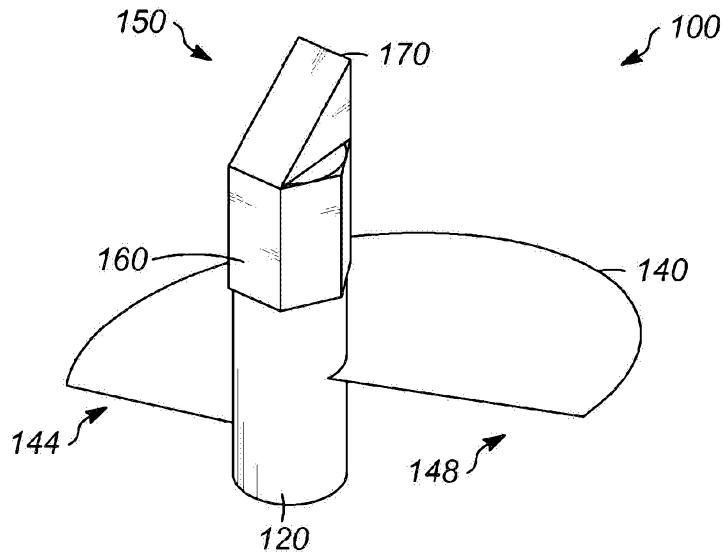

FIG. 3

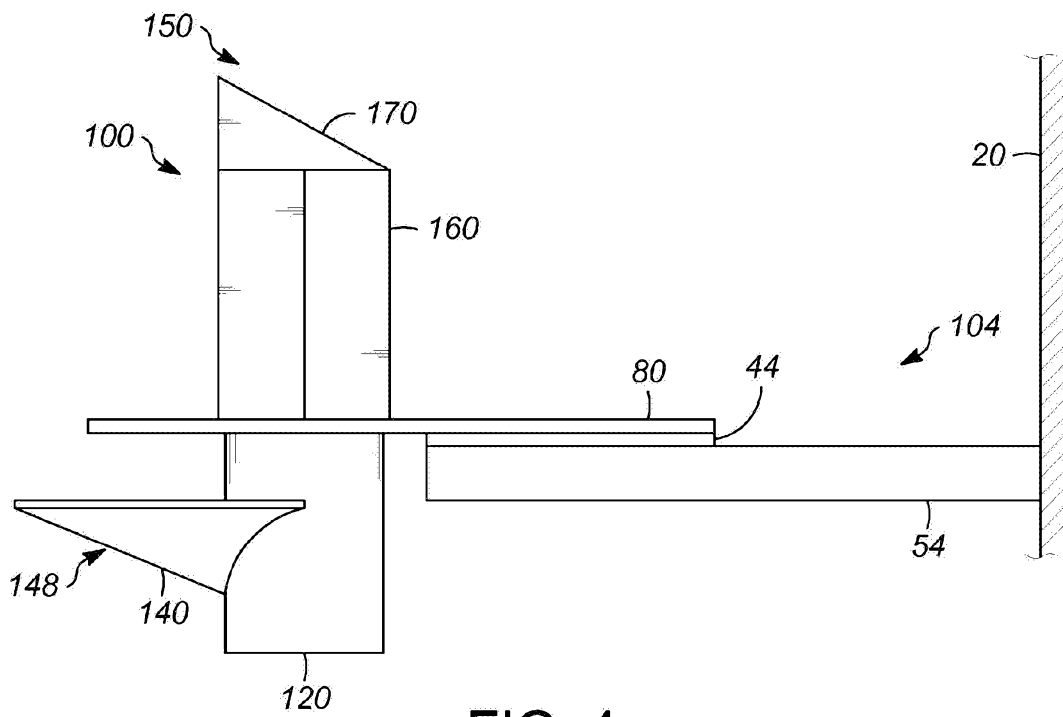

FIG. 4

