

L. A. DOUGHERTY.
MARINE MOTOR.
APPLICATION FILED JUNE 20, 1914.

1,166,749.

Patented Jan. 4, 1916.

2 SHEETS—SHEET 1.

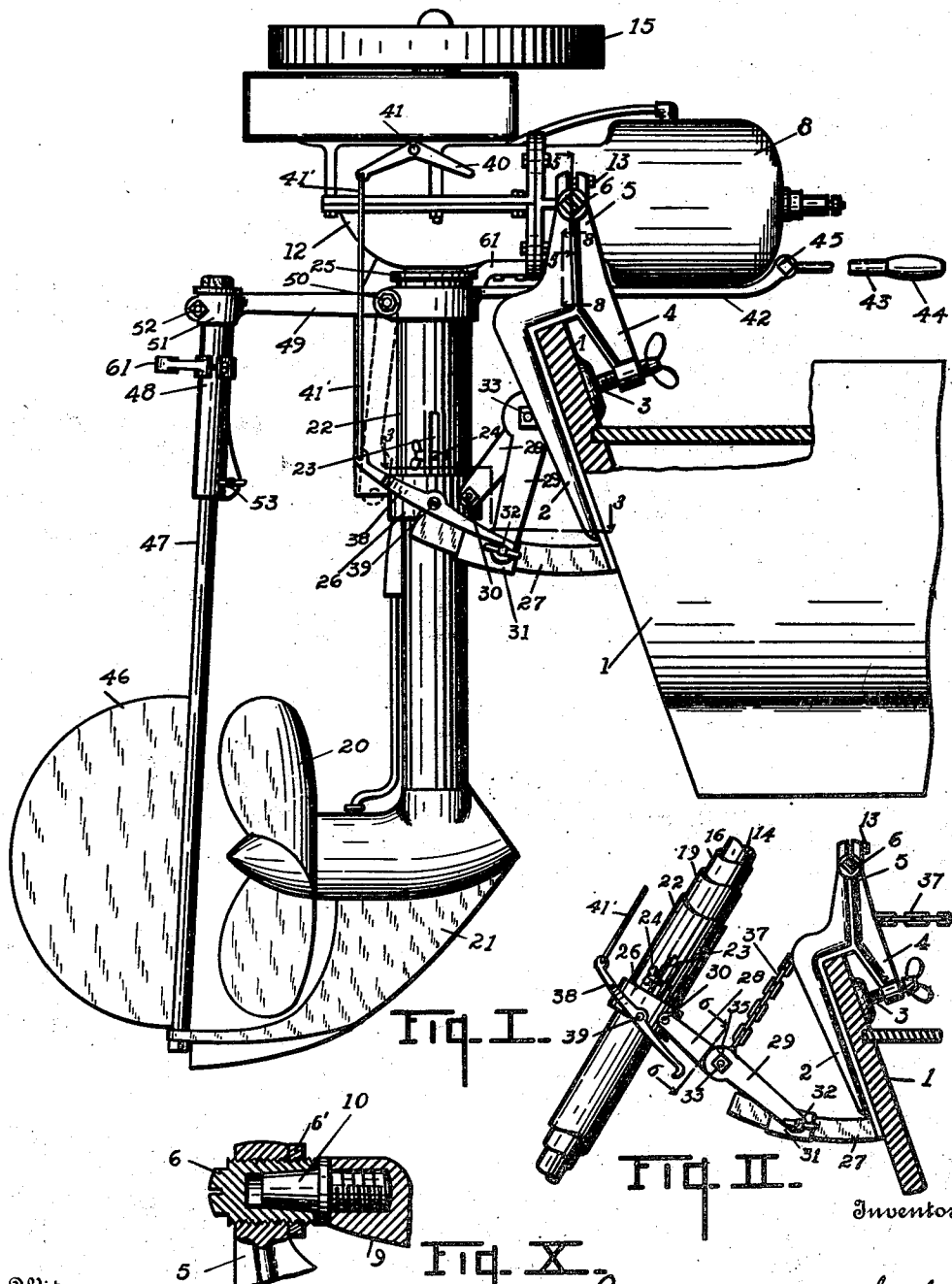

Witnesses

Luella Greenfield
Margaret L Glasgow

FIG. X

384

Lewis A. Dougherty
Chappell & East

Attorneys

L. A. DOUGHERTY.
MARINE MOTOR.

APPLICATION FILED JUNE 20, 1914

Patented Jan. 4, 1916.
2 SHEETS—SHEET 2.

1,166,749.

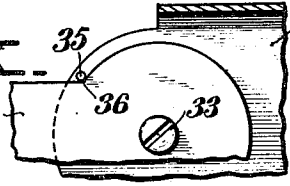
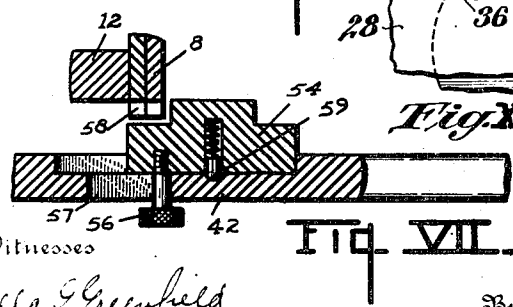
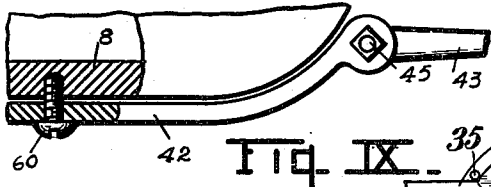
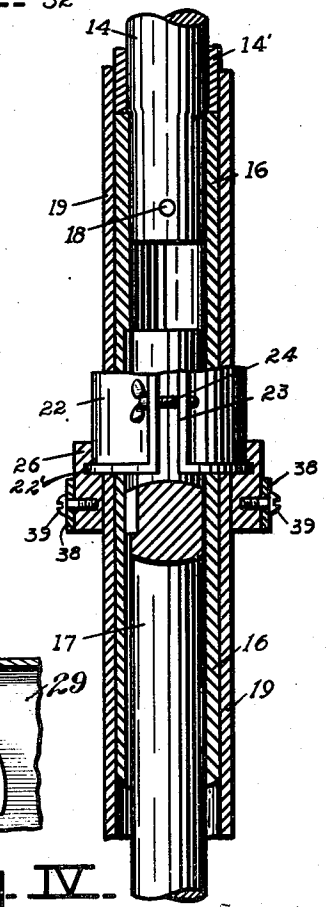
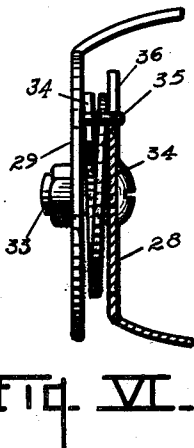
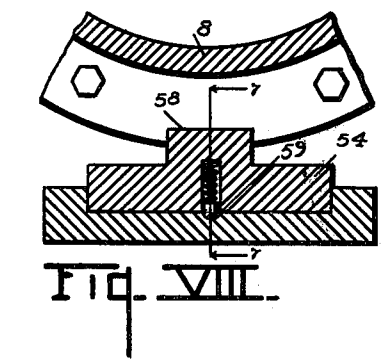
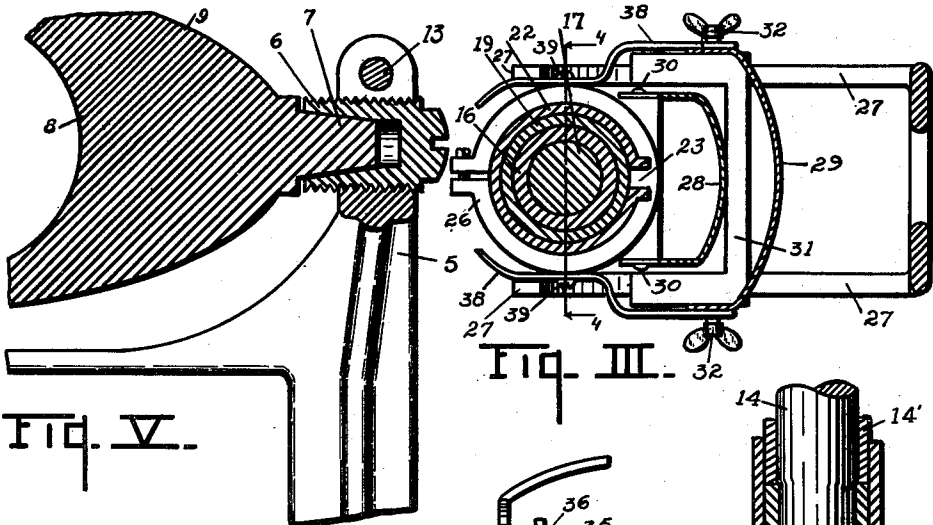

Witnesses
Lucia S. Greenfield
Margaret L. Hussey

Inventor
Lewis A. Dougherty
By Chappell & Co. Attorneys

UNITED STATES PATENT OFFICE.

LEWIS A. DOUGHERTY, OF ELKHART, INDIANA.

MARINE MOTOR.

1,166,749.

Specification of Letters Patent.

Patented Jan. 4, 1916.

Application filed June 20, 1914. Serial No. 846,335.

To all whom it may concern:

Be it known that I, LEWIS A. DOUGHERTY, a citizen of the United States, residing at Elkhart, in the county of Elkhart and State of Indiana, have invented certain new and useful Improvements in Marine Motors, of which the following is a specification.

This invention relates to improvements in marine motors.

The main objects of this invention are: First, to provide an improved marine motor adapted as an attachment for row boats, sail boats and the like. Second, to provide an improved marine motor which is readily attached to a row boat, sail boat or the like, and which is adjustable to swing the propeller out of the water or to inoperative position and also to permit the propeller to pass obstructions. Third, to provide an improved structure having these advantages which is comparatively simple and durable in structure and convenient to use.

Further objects, and objects relating to structural details, will definitely appear from the detailed description to follow.

I accomplish the objects of my invention by the devices and means described in the following specification.

The invention is clearly defined and pointed out in the claims.

A structure which is a preferred embodiment of my invention is clearly illustrated in the accompanying drawing forming a part of this specification, in which:

Figure I is a detail side elevation of my improved marine motor attached to a boat, the boat being partially in longitudinal sections to better show the arrangement of parts, the arm 49 being indicated in its collapsed position by dotted lines. Fig. II is a detail view with the motor supported in its inoperative position, the boat being shown in longitudinal section. Fig. III is a detail horizontal section on a line corresponding to the broken line 3—3 of Fig. I. Fig. IV is an enlarged detail partially in vertical section on a line corresponding to line 4—4 of Fig. III. Fig. V is an enlarged detail section on a line corresponding to line 5—5 of Fig. I, showing details of the mounting for the engine in the supporting basket. Fig. VI is a sectional view of the propeller support taken on a line corresponding to line 6—6 of Fig. II. Fig. VII is an enlarged detail view of the tiller lock taken on a line corresponding to line 7—7 of Fig. VIII.

Fig. VIII is a detail transverse section showing details of the tiller lock taken on a line corresponding to line 8—8 of Fig. I. Fig. IX is a detail perspective view of a modified form of tiller lock. Fig. X is a detail section of a modified form of engine supporting journals. Fig. XI is a detail side view of the link 28.

In the drawing similar reference characters refer to similar parts throughout the several views, and the sectional views are taken looking in the direction of the little arrows at the ends of the section lines.

Referring to the drawing, Fig. I is a side view of a boat to which my improved motor mechanism is secured as by means of the bracket 2, which is provided with a clamping screw 3 arranged through an arm 4 on the bracket. The bracket is provided with a pair of upwardly projecting arms 5 having bushing-like bearings 6 for the journals 7 of the cylinder 8. The journals are integral with the arms 9 projecting laterally from the sides of the cylinder 8. These arms are so disposed that the journals proper 7 are aligned with the horizontal center of the cylinder. The crank case 12 is bolted to the outer end of the cylinder as is well-known practice.

The journals 7 are tapered and the bearings 6 are tapered to receive them so that the parts can be nicely adjusted. The arms 5 of the brackets are split and the bushing-like bearings are threaded therein for adjustment, clamping bolts 13 being provided for clamping the bearings in their adjusted positions.

The crank shaft 14 has a fly wheel 15 on its upper end while its lower end projects from the bearing 14' into the tubular coupling 16 by which it is connected to the driving shaft 17, the driving shaft having a slip connection with the coupling 16, while the crank shaft is secured to the coupling by the pin 18. The shaft is provided with a housing 19 by which the propeller 20 is carried, the propeller shaft being horizontally disposed and secured to the driving shaft 17 by suitable beveled gears, not illustrated. The housing 19 also carries a shoe 21 which extends below and to the rear of the propeller 20. On the upper end of the housing 19 is a sleeve 22, the sleeve being split at 23 and provided with a clamping screw 24 by means of which the sleeve is clamped upon the housing so as to turn

therewith. The sleeve is provided with a flange 25 at its upper end which is engaged by the bracket 61 on the crank casing. See Fig. I. The sleeve 22 is provided with a flange 22' at its lower end with which the collar 26 is engaged. The collar and sleeve engage each other to permit rotative movement of the sleeve independent of the collar. On the lower end of the supporting bracket or frame are rearwardly projecting arms 27, the arms being curved or segmental in form. A support comprising a pair of links 28 and 29 is provided, the link 28 being pivoted to the collar 26 at 30, while the link 29 is pivoted to the adjustable slide member 31 on the arms 27 by the screws 32 which also secure the slide member in its adjusted positions. The links are pivotally connected to each other by the pivot 33. The links are preferably channel-shaped in cross section so one closes into the other as shown in Fig. III. Friction springs 34 are interposed between the links for applying friction thereto so that the motor is relieved from shock as it is thrown to its inoperative position or as it swings to permit the propeller to pass over an obstruction or returns to its operative position. The link 29 is provided with a pin 35 which coacts with a segment shaped notch 36 on the link 28 which prevents the links collapsing when extended. The pivot 33 of the links when extended swings past a plane extending through the pivots 30 and 32 so that the links constitute a toggle lock and the links do not tend to collapse and the propeller is supported in its raised position. A chain 37 is connected to the links for breaking the toggle. The clamp member 31 is slidable upon the arm 27 so that adjustment may be had at this point. For locking the propeller in its vertical position I provide a catch 38 which is bifurcated and pivoted on the collar 22 at the points 39 and the arms of which are adapted to engage the screws 32. The hand lever 40 is pivoted at 41 in convenient position to be reached by the operator. The lever is connected by the link 41' to the catch. See Fig. I. The tiller 42, which is clamped upon the sleeve 22, has a section 43 pivoted at 45 and provided with a hand piece 44 so that the oscillating movement of the motor on its supporting journals does not interfere with the operation of the tiller. The rudder 46 is carried by the rod 47, the lower end of which is supported by the shoe 21 and the upper end of which is secured by the sleeve 48 to the arm 49 projecting from the rear end of the tiller. The arm 49 is connected to the tiller by the bolt 50 and to the sleeve 48 by the clamp 51 provided with a clamping bolt 52. The sleeve is clamped to the upper end of the rod 47 by the clamping bolt 53. This permits of the removal of the rudder and when removed

the arm 49 is swung down against the sleeve 22, as shown by dotted lines in Fig. I, in which position it does not interfere with the normal operation of the motor, the propeller itself being used as the steering means. If it is desired to use only the rudder as a steering means the clamp 51 is loosened so that it serves as a bearing and cables, not shown, are attached to the cross arm 61 on the sleeve 48. I preferably, however, use the rudder as an addition to the propeller steering means.

It is sometimes desirable to lock the tiller in a central position and to accomplish this I provide the tiller with a lock 54 which is secured in its adjusted position by means of the set screw 56 arranged in a longitudinal slot 57 in the tiller 42 to secure the lock in its adjusted position, see Fig. VII. The lock is adapted to engage the notch-like keeper 58 in the cylinder flange, see Fig. VII. A stop pin 59 assists in locating the lock in its engaging and disengaging positions.

When it is desired to adjust the lock 54 the set screw 56 is loosened and the lock pushed longitudinally to or from engaging position as the case may be. The spring pressed stop pin 59 yields and does not prevent this as it retracts into its socket when the lock is pushed laterally and engages again when brought over the notch provided therefor.

In the modification shown in Fig. X the journals 10 are screwed into the arms 9 instead of being integral therewith as shown in the detail in Fig. V and the bearings 6 are secured in their adjusted position by the lock nuts 6'.

In the modification shown in Fig. IX, I provide a simple screw 60 for locking the tiller in a fixed position.

With the parts arranged as I have illustrated and described the motor may be quickly attached to or removed from a boat, such as a row boat or a sail boat. When using in shallow water or water in which there are logs or other debris the catch 38 is disengaged so as to allow the propeller to swing as its shoe passes over an object. The friction springs prevent shocks as the motor swings on its journals. When desired, the propeller may be swung out of the water and is automatically locked in its elevated position by means of the support described. The joint of the support is broken to release the same by a pull on the chain 37. The rudder is also convenient to operate and the combined action of the propeller and rudder are secured.

I have not attempted to maintain the proper proportions of the parts in the accompanying drawing as they are only intended to be illustrative.

Having thus described my invention, what

I claim as new and desire to secure by Letters Patent, is:

1. In a structure of the class described, the combination of a supporting bracket adapted for attachment to a boat, a horizontally disposed engine journaled on said bracket, a propeller, driving connections between said propeller and said engine, a tubular housing for said driving connections, said housing constituting a support for said propeller, a sleeve provided with flanges at its upper and lower ends clamped upon the upper end of said housing, a supporting bracket on said engine engaging the flange at the upper end of said sleeve whereby the housing is rotatably supported, a shoe on said housing extended below and to the rear of the propeller, a collar rotatably engaging the flange at the lower end of said bracket, a pair of rearwardly projecting spaced arms on said bracket, said housing being adapted to swing between said arms, a pair of links U-shaped in cross section pivotally connected to each other to collapse one within the other, one of said links being pivotally connected to said collar on said housing and the other to a clamp member adjustably mounted on said rearwardly projecting arms on said bracket, the connecting pivot for said links to each other and to said collar and clamp member being disposed so that the links when extended constitute a locking toggle, a friction spring interposed between said links, stops for limiting the movement of said links, a trip means for said links, a bifurcated catch embracing said collar and pivotally mounted thereon to engage the pivots connecting the link to said clamp member, and means for operating said catch.

2. In a structure of the class described, the combination of a supporting bracket adapted for attachment to a boat, a horizontally disposed engine journaled on said bracket, a propeller, driving connections between said propeller and said engine, a tubular housing for said driving connections, said housing constituting a support for said propeller, a sleeve provided with flanges at its upper and lower ends clamped upon the upper end of said housing, a supporting bracket on said engine engaging the flange at the upper end of said sleeve whereby the housing is rotatably supported, a shoe on said housing extended below and to the rear of the propeller, a collar rotatably engaging the flange at the lower end of said bracket, a pair of rearwardly projecting spaced arms on said bracket, said housing being adapted to swing between said arms, and a pair of links U-shaped in cross section pivotally connected to each other to collapse one within the other, one of said links being pivotally connected to said collar on said housing and the other to a clamp member adjustably mounted on said rearwardly

projecting arms on said bracket, the connecting pivot for said links to each other and to said collar and clamp member being disposed so that the links when extended constitute a locking toggle.

3. In a structure of the class described, the combination of a supporting bracket adapted for attachment to a boat, an engine journaled on said bracket, a propeller, driving connections between said propeller and said engine, a housing for said driving connections, said housing constituting a support for said propeller, said housing being rotatably supported, a shoe on said housing, a collar mounted on said housing, a pair of rearwardly projecting spaced arms on said bracket, said housing being adapted to swing between said arms, a pair of links U-shaped in cross section pivotally connected to each other to collapse one within the other, one of said links being pivotally connected to said collar on said housing and the other to a clamp member adjustably mounted on said rearwardly projecting arms on said bracket, the connecting pivot for said links to each other and to said collar and clamp member being disposed so that the links when extended constitute a locking toggle, stops for limiting the movement of said links, a trip means for said links, and a bifurcated catch embracing said collar and pivotally mounted thereon to engage the pivots connecting the link to said clamp member.

4. In a structure of the class described, the combination of a supporting bracket adapted for attachment to a boat, an engine journaled on said bracket, a propeller, driving connections between said propeller and said engine, a housing for said driving connections, said housing constituting a support for said propeller, said housing being rotatably supported, a shoe on said housing, a collar mounted on said housing, a pair of rearwardly projecting spaced arms on said bracket, said housing being adapted to swing between said arms, and a pair of links U-shaped in cross section pivotally connected to each other to collapse one within the other, one of said links being pivotally connected to said collar on said housing and the other to a clamp member adjustably mounted on said rearwardly projecting arms on said bracket, the connecting pivot for said links to each other and to said collar and clamp member being disposed so that the links when extended constitute a locking toggle.

5. In a structure of the class described, the combination of a supporting bracket adapted for attachment to a boat, an engine journaled on said bracket, a propeller, driving connections between said propeller and said engine, a housing for said driving connections, said housing constituting a support

- for said propeller, a sleeve provided with flanges at its upper and lower ends clamped upon the upper end of said housing, a supporting bracket on said engine engaging the flange at the upper end of said sleeve where-
 5 by the housing is rotatably supported, a shoe on said housing extended below and to the rear of the propeller, a collar rotatably engaging the flange at the lower end of said sleeve, a rearwardly projecting arm on said
 10 bracket, a pair of links pivotally connected to each other, one of said links being pivotally connected to said collar on said housing and the other to a clamp member adjustably
 15 mounted on said rearwardly projecting arm on said bracket, the connecting pivot for said links to each other and to said collar and clamp member being disposed so that the links when extended constitute a locking
 20 toggle, a friction spring interposed between said links, a stop for limiting the movement of said links, and a catch pivotally mounted on said collar to engage the pivot connecting the link to said clamp member.
- 25 6. In a structure of the class described, the combination of a supporting bracket adapted for attachment to a boat, an engine journaled on said bracket, a propeller, driving
 30 connections between said propeller and said engine, a housing for said driving connections, said housing constituting a support for said propeller, a sleeve provided with flanges at its upper and lower ends clamped
 35 upon the upper end of said housing, a supporting bracket on said engine engaging the flange at the upper end of said sleeve whereby the housing is rotatably supported, a shoe on said housing extended below and to the rear of the propeller, a collar rotatably
 40 engaging the flange at the lower end of said sleeve, a rearwardly projecting arm on said bracket, and a pair of links pivotally connected to each other, one of said links being pivotally connected to said collar on said
 45 housing and the other to a clamp member adjustably mounted on said rearwardly projecting arm on said bracket, the connecting pivot for said links to each other and to said collar and clamp member being disposed so
 50 that the links when extended constitute a locking toggle.
7. In a structure of the class described, the combination of a supporting bracket adapted for attachment to a boat, an engine
 55 journaled on said bracket, a propeller, a driving connection between said propeller and said engine, a housing for said driving connection, said housing constituting a support for said propeller, a rearwardly projecting
 60 arm on said bracket, a pair of links pivotally connected to each other, one of said links being pivotally supported by said housing, the other to a clamp member adjustably mounted on said rearwardly projecting
 65 arm on said bracket, the connecting pivot for said links to each other and to said clamp member being disposed so that the links when extended constitute a locking toggle, a friction spring interposed between said links, a trip for said links, and a catch for holding the housing in its operative position.
8. In a structure of the class described, the combination of a supporting bracket adapted for attachment to a boat, an engine
 75 journaled on said bracket, a propeller, driving connections between said propeller and said engine, a housing for said driving connections carried by said engine and constituting a support for said propeller, a sleeve
 80 provided with a flange at its lower end mounted on said housing, a collar rotatably engaging the flange at the lower end of said sleeve, and a pair of links pivotally connected to each other, one of said links
 85 being pivotally connected to said collar and the other to said supporting bracket.
9. In a structure of the class described, the combination of a supporting bracket adapted for attachment to a boat, an engine
 90 journaled on said bracket, a propeller, driving connections between said propeller and said engine, a support for said propeller carried by said engine, a collar on said propeller support, a pair of toggle links piv-
 95 otally connected to each other, one of said links being pivotally connected to said collar and the other to said supporting bracket, and a stop for supporting said links when extended positioned so that the pivot con-
 100 necting the links swings past the plane of the link supporting pivots whereby the links when extended support said propeller in inoperative position.
10. In a structure of the class described, the combination of a supporting bracket
 105 adapted for attachment to a boat, an engine journaled on said bracket, a propeller, a support for said propeller mounted on said engine, driving connections between said
 110 propeller and said engine, a pair of toggle links pivotally connected to each other and to said propeller support and bracket, a stop for supporting said links when extended positioned so that the pivot con-
 115 necting the links swings past the plane of the link supporting pivots whereby the links when extended support said propeller in inoperative position, and a catch for securing the propeller support with the propeller in
 120 operative position.
11. In a structure of the class described, the combination of a supporting bracket adapted for attachment to a boat, an engine
 125 journaled on said bracket, a propeller, a support for said propeller mounted on said engine, driving connections between said propeller and said engine, a pair of toggle links pivotally connected to each other and
 130 to said propeller support and bracket, and a

stop for supporting said links when extended positioned so that the pivot connecting the links swings past the plane of the link supporting pivots whereby the links when extended support said propeller in inoperative position.

12. In a structure of the class described, the combination of a supporting bracket adapted for attachment to a boat, an engine journaled on said bracket, a propeller, a support for said propeller mounted on said engine, driving connections between said propeller and said engine, a pair of links pivotally connected to each other and to said propeller support and bracket, said links constituting a jointed brace for supporting said propeller in an inoperative position, and a friction member between said links.

13. In a structure of the class described, the combination of a supporting bracket adapted for attachment to a boat, an engine journaled on said bracket, a propeller, driving connections between said engine and said propeller, a housing for said driving connections constituting a propeller support, a sleeve clamped to said housing and provided with a flange at its upper end, a bracket on said engine engaging said flange whereby the housing is rotatably supported, a tiller clamped upon said sleeve, an arm pivoted on said tiller and adapted to be folded down at the side of said sleeve, a rudder, a rearwardly projecting shoe carried by said housing, and a rudder rod mounted on said shoe, said arm on said tiller being secured to the upper end of said rod.

tiller being secured to the upper end of said rod.

14. In a structure of the class described, the combination of a supporting bracket adapted for attachment to a boat, an engine journaled on said bracket, a propeller, driving connections between said engine and said propeller, a housing for said driving connections constituting a propeller support, a sleeve clamped to said housing and provided with a flange at its upper end, a bracket on said engine engaging said flange whereby the housing is rotatably supported, and a tiller secured to said sleeve.

15. In a structure of the class described, the combination of a supporting bracket adapted for attachment to a boat, an engine journaled on said bracket, a propeller, driving connections between said engine and said propeller, a housing for said driving connections constituting a propeller support rotatably mounted on said engine, a tiller secured to said housing, an arm pivoted on said tiller and adapted to be folded down at the side of said housing, a rudder, a rearwardly projecting shoe carried by said housing, and a rudder rod mounted on said shoe, said arm on said tiller being secured to the upper end of said rod.

In witness whereof, I have hereunto set my hand and seal in the presence of two witnesses.

LEWIS A. DOUGHERTY. [L. S.]

Witnesses:

LUELLA G. GREENFIELD,
MARGARET L. GLASGOW.