

19



NL Octrooi Centrum

11

2003998

12 C OCTROOI

21 Aanvraagnummer: **2003998**

51 Int.Cl.: **H01J 37/147** (2006.01) **H01J 37/05** (2006.01)
G21K 1/093 (2006.01)

22 Aanvraag ingediend: **21.12.2009**

30 Voorrang:
23.12.2008 DE 10 2008 062 888

43 Aanvraag gepubliceerd:
30.06.2010

47 Octrooi verleend:
09.04.2013

45 Octrooischrift uitgegeven:
17.04.2013

73 Octrooihouder(s):
**Carl Zeiss NTS GmbH te Oberkochen,
BONDSREPUBLIEK DUITSLAND (DE).**

72 Uitvinder(s):
**Dirk Preikszas te Oberkochen (DE).
Michael Steigerwald te Westhausen (DE).
Daniel Tobias te Jena (DE).
Andreas Eisele te München (DE).
Momme Mommsen te Aalen (DE).
Dietmar Doenitz te Aalen (DE).
Christian Hendrich te Aalen (DE).**

74 Gemachtigde:
Mr. G.L. Kooy c.s. te Den Haag.

54 Particle optical device with magnet assembly.

57 A particle optical apparatus has a particle source for generating at least one beam of charged particles, and a magnet arrangement having two pole plates, which are arranged spaced apart from one another, such that the at least one beam of charged particles in operation passes through the pole plates, wherein trenches are provided in the pole plates, in which trenches coil wires are arranged. The trenches, when viewed in a cross section transverse to an extension direction of the trenches, have a smaller width in a region of a surface of the pole plates, than in a region arranged at a distance from the surface.

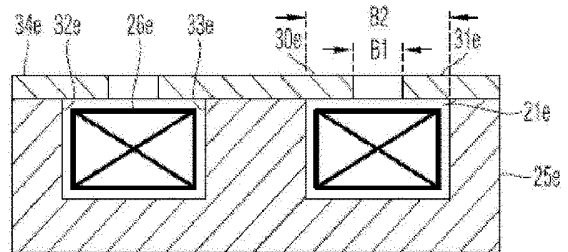

NL C 2003998

Dit octrooi is verleend ongeacht het bijgevoegde resultaat van het onderzoek naar de stand van de techniek en schriftelijke opinie. Het octrooischrift wijkt af van de oorspronkelijk ingediende stukken. Alle ingediende stukken kunnen bij NL Octrooi Centrum worden ingezien.

Nr. NLP186483A

Particle optical device with magnet assembly

Field of the Invention

The present invention relates to a particle optical device, and in particular to an electron microscope, 5 having a magnet assembly.

Electron microscopes are used for examining an object by directing a primary electron beam towards the object to be examined, whereupon electrons emanating from the object are guided to a detector as a secondary electron 10 beam, and detected there.

For electron microscopes, there exists a demand for deflecting the primary and/or the secondary electron beam in a precise manner, e.g. about an angle of 10° or more; or to separate an electron beam from a counter- 15 propagating electron beam, for being able to separately manipulate these beams. For an electron microscope operating in 180° -deflection, or an electron microscope with a mirror corrector, this means that both beams have to pass a deflecting field of a beam separator.

20

Brief Description of the Related Art

For beam guiding, magnetic fields are usually employed, which have to fulfill high demands concerning

their homogeneity, stability and edge effects. Metal plates with a high magnetic conductivity, usually of an iron-nickel-alloy, can be placed at a fixed distance opposite from one another as pole plates for generating these magnetic fields. Coils are fitted into the surfaces of the pole plates, which coils may be energized by a flow of current. A magnetic field which is homogeneous to a high degree of approximation is then generated on the areas surrounded by the coil wires. Such a device is known from German Patent No. 102 35 981.

The demands on the stability and accuracy of the geometry of the pole plates are tremendous, in particular for the electron microscopes with a mirror corrector mentioned above.

Conventionally, the heat generated by energizing the coils is dissipated through the pole plates. The present inventors have now found that thereby, temperature gradients are caused, which affect the geometry of the pole plates. Additionally, temperature drifts may result, when the amount of energizing has to be changed. These influences result in undesirable variations of the deflecting field.

It is therefore an object of the invention to overcome the drawbacks and deficiencies of the prior art.

Summary of the Invention

The present invention sets out from a particle optical device with

- a particle source for generating at least one beam of charged particles, and

- a magnet assembly including two pole plates, which are arranged spaced apart from one another, so that in operation, the beam of charged particles passes between the two pole plates, wherein trenches are provided in the pole plates, in which trenches coil wires are arranged.

Generally, the concept contemplated in this application resides in reducing and/or in stabilizing the

generation of heat in the coils, and/or in reducing the transfer of heat from the coils into the pole plates.

According to a first aspect, a particle optical device is provided, in which the coil trenches have a
5 smaller width in surface regions of the pole plate, than in regions located at a distance from the surface.

Thereby, more space is provided in some embodiments for the total cross section of the coil wires, without substantially compromising the particle optical
10 properties of the pole plates essentially determined by their surface contours. The heat generation for a like energizing current is reduced by the larger cross section of the conductor, and the accordingly lower (electric) resistance.

15 The enlargement of the trench cross section can, in some embodiments, be effected inwardly, outwardly or in both radial directions in relation to the conductor loop.

According to a second aspect, a particle optical device including a coil mount is provided, on which coil
20 mount the coil wires are supported, wherein a gap is provided between the coil mount and the pole plate.

According to this structure, in some embodiments the heat transfer from the coil wires to the pole plates via heat conduction is reduced, particularly in a case where the
25 pole plates and the coils are located in a vacuum. The heat dissipation from the coils may occur around the pole plates or through holes provided therein, respectively, e.g. using pillar-like stands made of a heat conducting material and extending through the holes.

30 In some embodiments, such an arrangement allows that generated heat is conducted to a cooling device bypassing the pole plates.

According to a third aspect, a particle optical device including two layers of an electrically conducting
35 and nonmagnetic material is provided, which layers are arranged between the two pole plates, and which extend on either side of the beam of charged particles.

According to some embodiments, an environment for the beam may be provided, to which a high voltage can be applied, while the sample and the coils are on ground or near-ground potential. While the current supply for the coils is simple, an electrical voltage may in operation be applied e.g. to parts of the sample, and the electron energy at the sample is variable. The nominal electron energy between the pole plates, however, remains constant, and likewise the magnetic field needed for deflection and therefore the energizing current. As a consequence, the remaining heat input into the pole plates through heat loss of the coils (e.g. via heat radiation) remains constant and, thus, temperature drift is reduced.

According to a fourth aspect, a particle optical device is provided, in which the coil wires are isolated thermally and with respect to high voltage from the pole plates, and the latter are put on a higher electric potential than the coil wires.

According to some embodiments, this results that on the one hand, the coil wires do not undergo thermal variations, and on the other hand, that the heat input into the pole plates is small. In some embodiments, this structure can be combined with that according to the first aspect, such that the increased space requirement in the coil trench may not result in a reduced cross section of the coil wires.

According to a fifth aspect, a particle optical device having a permanent magnet is provided, which is located within the coil arrangement as projected onto the beam plane.

According to some embodiments, this arrangement results in the main portion of the magnetic field to be generated being provided by the permanent magnet, while only a comparatively smaller portion is provided by the coil arrangement. Thereby, the current flow through the coils, and accordingly the heat input into the pole plates is reduced, and as a result also the influence on the pole

plate geometry.

In some embodiments, a magnetic flow density of the material used for the permanent magnet is particularly little influenced by the temperature. This small dependency
5 on the temperature can, in embodiments, be compensated for using a control e.g. measuring the temperature and applying a corresponding correction current to the coils as described e.g. in German patent No. 102 35 455.

Generally, two or more or all of the above aspects
10 may be combined with one another.

Hereinabove, the particle optical device is not restricted to electrons, but also ions, myons or others may serve as the charged particles. A preferred application of the particle optical device, however, is in the field of
15 electron microscopy.

The particle optical device may be used in several different types of electron microscopes. These comprise, on the one hand, such devices in which the primary electron beam is an examining beam focused onto specific locations on
20 the object, in particular focused successively onto distinct locations, and wherein a secondary electron intensity is detected integrally, i.e. is not spatially resolved. These types of microscopes are known in the art as SEMs (Scanning Electron Microscope). On the other hand, the devices
25 comprise electron microscopes with a spatially resolving detector onto which an extended area of the object is imaged, wherein the extended area is simultaneously and essentially uniformly illuminated by the primary electron beam. These types of microscopes are known in the art, among
30 others, as LEEM (low energy electron microscope), SEEM (secundary electron emission microscope) or TEM (transmission electron microscope).

Brief Description of the Drawings

35

The forgoing as well as other advantageous features of the invention will be more apparent from the following detailed

description of exemplary embodiments of the invention with reference to the accompanying drawings, wherein

Figure 1 shows schematically a conventional electron microscope of the SEM type;

5 Figure 2 shows schematically an arrangement of field regions of the beam splitter according to Figure 1;

Figure 3 shows schematically a cross section through one field region of the beam splitter shown in Figures 1 and 2 with an example of a current conductor
10 arrangement;

Figure 4 shows schematically two other possible magnet and coil arrangements;

Figure 5a shows schematically a magnet arrangement for a particle optical device according to an embodiment;

15 Figure 5b shows schematically a similar magnet arrangement as the one of Figure 5a;

Figure 5c shows schematically a similar magnet arrangement as the ones of Figure 5a and 5b;

Figure 6a shows schematically a top view of a magnet arrangement for a particle optical device according
20 to another embodiment;

Figure 6b shows schematically a cross sectional view to the top view of Figure 6a along the line A- -A;

Figure 7 shows schematically a magnet arrangement
25 for a particle optical device according to a further embodiment;

Figure 8 shows schematically a magnet arrangement for a particle optical device according to still another embodiment; and

30 Figure 9 shows schematically a magnet arrangement for a particle optical device according to yet another embodiment.

The modifications shown in Figures 5 to 9 can be combined in some embodiments.

35

Detailed Description of Exemplary Embodiments

The operating principle of an electron microscope of the SEM type is explained in Figure 1. The electron microscope 100 includes a particle source 1 with a beam accelerator 2 following the particle source 1 in the direction of the beam. After passing through the beam accelerator 2, the particles are accelerated to the potential of the outer beam guide tube 3. In this region, a magnetic condenser lens 4 and a stigmator 5 following same are envisaged. A first electrostatic immersion lens 6a follows the stigmator 5, by which lens 6a the electrons are accelerated or decelerated, respectively, to another kinetic energy, namely that of the inner beam guide tube 7. The beam splitter 8 with its magnet sectors 8a to 8c is arranged in the region of the inner beam guide tube 7. The beam splitter 8 is followed by a second electrostatic immersion lens 6b, by which the electrons are decelerated or accelerated, respectively, to the energy of the objective beam tube 9. Following this in the direction of the beam, a multipole system including 12-pole-elements 11, 13 and deflecting systems 10, 12, 14 are arranged, as well as, close to the object 15, an objective lens 16 having a diffraction plane 17. The objective lens 16 focuses the incident electron beam onto the focal plane 18 of the objective lens 16. Herein, the objective lens 16 can be configured as a purely magnetic objective lens, or as a combination with an electrostatic immersion lens. In the latter case, the immersion lens is formed by letting the objective beam tube 9 end within the objective lens 16 at a position of the pole shoe gap or behind, and by decelerating the electrons to the potential of the object 15 positioned in the vicinity of the focal plane 18 after exiting from the objective beam tube 9.

The pair of immersion lenses 6a, 6b further allows for compensating variations of the electron energy, such that the electron beam passing through the beam splitter 8 has a substantially constant energy.

The secondary electrons generated through interaction of the primary electron beam with the object 15

are accelerated back by the higher potential of the objective beam tube 9 and pass through the beam path between the objective lens 16 and the beam splitter 8 in opposite direction. Due to their reversed direction of motion, the
5 electrons are deflected in the magnet sector 8c in the opposite direction, so that they are spatially separated from the primary electron beam. The secondary electrons can be detected by means of a detector 20 following the deflected branch of the beam splitter. A discrimination
10 regarding the energies of the electrons coming from the sample, in particular according to mirror electrons, back scattered electrons, and several kinds of secondary electrons, is possible by means of an electrostatic lens 19 placed in front, to which different potentials are applied.

15 Figure 2 elucidates the arrangement of beam regions and field regions in the beam splitter 8. This exemplary beam splitter 8 consists of overall three magnet sectors 8a, 8b, 8c with surrounding current conductors (not shown) which are uniformly bent as regards the direction of
20 the bends, and are placed in according conductor guides 21a, 21b, 21c. The two outer sectors 8a, 8c may have identical structure, but it is sufficient if this symmetry holds for those beam regions transected by the primary electron beam. The directions of the magnetic fields B_a and B_c , in
25 embodiments also their strengths, are the same in these outer sectors 8a, 8c, while the magnetic field B_b of the inner sector 8b has the opposite direction. The inner magnetic sector 8b is symmetrical in itself, and arranged symmetrically to the plane 23 indicated by the dashed line
30 in Figure 2. Accordingly, the field regions including the field-free regions are symmetrically arranged, and therefore likewise the beam regions transected by the beam. In addition, all the magnetic fields are parallel or anti-parallel, respectively, so that the primary electron beam
35 passes coplanarly through the beam splitter, namely in the beam plane 24 (see Figure 3). Figure 2 thus represents a projection onto the beam plane 24.

The beam deflection within the beam splitter 8 results in a beam deflection of about 90° in this example, between the first and second beam axes BA1, BA2.

Figure 3 illustrates the principal design of the magnet sectors 8a, 8b, 8c. This drawing corresponds to a cross sectional view of the magnet sector 8a shown in Figure 2, approximately along the line (III- -III). The pole shoes 25 and the pair of coils 26 arranged in the conductor guide 21 are shown, as well as pairs of trim coils 27 serving for fine adjustment. In the space enclosed by the coils 26, the magnetic field B_a is generated. Yokes magnetically connecting the pole shoes 25 outside of the region surrounded by the current conductor, and required for completing the magnetic field flow, are not shown. Further, the yokes define the distance between the pole shoes. Both pole shoes 25 and the yokes may be made of soft iron, ferrite, an iron-nickel-alloy or another magnetic material. The coil wires may be made of a high conductance copper alloy or the like.

Figure 4 illustrates two alternative structures of the pole shoes, wherein functionally corresponding components bear like numerals as above, but with subscript small letters: In the upper part of this drawing, a bowl-shaped pole plate 25a" with an island pole 25a' is shown, between which the coil 26a is arranged. The surface of the pole plate is labeled 34. The pole plate 25a" and the island pole 25a' are assembled with one another such that between them, a sufficient magnetic connection is provided, and together they form the pole shoe. Similarly, in the lower part of Figure 4 a variant is shown, in which the pole shoe is formed by an island pole 25a', a ring-shaped pole plate 25b" and a back plate 28, between which the coil 26 is located, as before.

In the embodiment according to Figure 5a, the pole plate 25c has a pole lid 30c in its central portion, the pole lid partly covering the coil trench 21c from the radially inward side, such that only the outer wall 32 of the trench is formed by a single piece of the pole plate

25c. Thereby, the width B1 of the trench at the surface 34c of the pole plate 30c is less than the width B2 of the trench below the surface 34c. The width B1 as well as B2 may vary along the circumference of the poles.

5 Analogously, in the embodiment according to Figure 5b the pole plate 25d has, in its peripheral region, a ring-shaped pole lid 31d partly covering the coil trench 21d from the radially outward side, so that only the inner wall 33 of the trench is formed from a single piece of the pole plate
10 25d. Thereby, the width B1 of the trench at the surface 34d of the pole plate 30d is again less than the width B2 of the trench below the surface 34d. The width B1 as well as B2 may again vary along the circumference of the poles.

In the embodiment according to Figure 5c, the
15 modifications according to Figures 5a and 5b are combined: The pole plate 25e has a ring-shaped pole lid 31e in its peripheral region, as well as a pole lid 30e in its central portion, together partly covering the coil trench 21d from the radially inward and outward sides, so that neither the
20 inner wall 33e nor the outer wall 32e of the trench is formed from a single piece of the pole plate 25e. Thereby, the width B1 of the trench at the surface 34e of the pole plate 30e is more reduced compared with the width B2 of the trench below the surface 34e. The width B1 as well as B2 may
25 again vary along the circumference of the poles.

In the top view according to Figure 6a, it is shown how, in addition to a lead-through 36 for the coil wire terminal, plural through holes 38 for pillars of a coil mount (see Figure 6b) are distributed in the bottom of the
30 coil trench 21f. The number of these through holes may e.g. vary between 3 and 9, or between 5 and 7.

It will become evident from the corresponding side view according to Figure 6b, that the coil wires 26f are mounted on a ring-shaped coil mount 40', or a mount forming
35 a substantially closed ring, having e.g. an L-shaped profile. This ring 40' is itself mounted on top of several pillars 40" made of a material well conducting heat, e.g.

copper or aluminum. A gap 41 is provided between the coil mount 40' and the pillars 40", on the one hand, and the pole plate 25f on the other hand. The gap 41 presents a bar to direct flow of heat to the pole plate 25f. The heat is
5 conducted via the pillars 40" to a common, e.g. plate-like base 42. It is also envisaged to provide active cooling devices (not shown), e.g. water or air cooling, or a Peltier element. The arrangement for mounting the coils 40', 40", 42 is held in place in its position relative to the pole plate
10 25f by a heat-isolating spacer 44.

The modifications mentioned above relate to the plate or trench geometry in a wider sense. Independently from, or in combination with, the modifications already mentioned, the following embodiments relate to the
15 electrical configuration: According to Figure 7, a double layer 46 of an electrically conductive, but non-magnetic material, e.g. a thin copper or gold layer, is provided between the pole plates 25g, exemplarily shown here in the basic version of Figure 3. An upper limit for the tolerable
20 magnetic susceptibility of this material is $\mu_r < 1.01$. The material layer shall further be sufficiently electrically conductive such as to not accumulate electric charges. In the example according to Figure 7, the electrically
25 conductive layers 46, between which the beam of particles passes through, are each supported by an isolating layer 48 substantially or entirely filling the space between the layers 46 and the respective adjacent pole plate 25g. The isolating layers 48 may be formed monolithically, with only the holes for the ingoing and outgoing particle beams are
30 provided; such a configuration obviates protective measures otherwise necessary due to the high voltage to be applied to the double layer 46 and the pole plates 25g. Herein, the isolator may be formed by hollowing out a massive block to form a so-called beam box. Alternatively, the hollow block
35 may be constructed directly in the desired shape e.g. by Rapid Prototyping. In both cases, surface pairs are avoided which would be unavoidable e.g. if several parts would be

assembled by screwing together, and which might provide electrical break-through paths. The layers 46, together with head-on apertures transmitting the particle beam, form the beam box 45, within which the particles are at a defined electrical potential.

In Figure 8, a variant is shown in which the coil winding 26h is surrounded as a whole by an electrically and thermally isolating layer 50, such that the latter occupies substantially the entire space in the coil trench 21h left by the coil winding 26h. In this example, the pole plate geometry according to Figure 5c is taken as basis, in order to have available as much space as possible for the isolation, and to at the same time provide an as large as possible current conductor cross section for the coil wires 46h. Other pole plate types than those with a ring-shaped pole lid 31h and an island-like pole lid 30h are also conceivable. In this arrangement, the coil may be provided at a different potential than the pole plate; furthermore, the heat transfer is reduced. The fact that the pole plate does not serve as a heat sink in this embodiment, and that the coils heat up more as a consequence, is not critical in respect of the constancy and precision of the magnetic field at least as long as a tolerance gap 51 remains between the isolation 50 and the wall 33h of the coil trench 21h, of the isolation 50 is compressible. In this embodiment, the coil itself dissipates the major part of the heat generated in operation, via the coil wires.

A further possibility is shown in Figure 9: Herein, a permanent magnet 554 is arranged below an island pole 52, namely a plate made of a magnetic material, which at its periphery defines the coil trench. The permanent magnet provides the larger part of the magnetic flow required. The coil wires 46h in operation carry considerably less current than in the examples without a permanent magnet discussed above at the same magnetic field, because they provide only a minor part of the total magnetic field strength. The permanent magnet 54 cannot be provided with an

exact magnetic field strength, and furthermore its field depends - albeit only a little - from the temperature. Therefore, in this example, a temperature sensor 55 is provided, the output signal of which is used to adjust the
5 power supply voltage DC of the coils 26i by means of a controller 56 and a regulator 57, such that field variations are compensated. A power supply for the coils is also provided in the embodiments described previously; in addition, a controller may likewise be provided in each of
10 these embodiments.

To summarize, the invention provides systems with which the heat generation of the coils and/or the heat transfer from the coils into the pole plates may, in embodiments, be reduced and/or stabilized. The skilled
15 person will conceive of variations to the embodiments presented above, which variations are nevertheless covered by the appended claims.

C O N C L U S I E S

1. Deeltjes-optische inrichting omvattend:
een deeltjesbron voor het genereren van ten minste één straal van geladen deeltjes;
een magneetopstelling met twee poolplaten, die op
5 afstand van elkaar zijn gerangschikt, zodanig dat in werking de ten minste één straal van geladen deeltjes tussen de poolplaten door gaat, waarbij geulen zijn verschaft in de poolplaten, in welke geulen spoeldraden zijn gerangschikt, en
10 een spoelondersteuning die de spoeldraden ondersteunt, waarbij een tussenruimte is verschaft tussen de spoelondersteuning en de poolplaat.
2. Deeltjes-optische inrichting volgens conclusie 1, waarin de spoelondersteuning ten minste één pilaar omvat
15 die zich door een gat dat is verschaft in de poolplaat heen uitstrekt en uitsteekt uit een achterzijde van de poolplaat die tegenovergesteld gelegen is van het oppervlak van de poolplaat.
3. Deeltjes-optische inrichting volgens conclusie
20 2, waarin de spoelondersteuning een veelvoud aan pilaren en een basis omvat, waarin het veelvoud aan pilaren gezamenlijk worden ondersteund door de basis.
4. Deeltjes-optische inrichting volgens conclusie
2 of 3, waarin de tussenruimte de spoelondersteuning
25 volledig omringt.
5. Deeltjes-optische inrichting volgens een der conclusies 1 - 4, verder omvattend een koelinrichting die warmtegeleidend verbonden is met de spoelondersteuning.
6. Deeltjes-optische inrichting volgens een der
30 conclusies 1 -5, waarbij de geulen, wanneer bezien in een doorsnede dwars op een richting waarin de geulen zich uitstrekken, een smallere breedte hebben in een gebied van een oppervlak van de poolplaten, dan in een gebied dat op

een afstand van het oppervlak is gerangschikt.

7. Deeltjes-optische inrichting volgens conclusie 6, waarbij de breedte in het gebied dat op een afstand van het oppervlak is gerangschikt ten minste 1,5 keer zo groot is als de breedte bij het oppervlak.

8. Deeltjes-optische inrichting volgens conclusie 6 of 7, waarin ten minste één van de poolplaten een uitneembaar stuk omvat dat de breedte van de geul in het gebied van het oppervlak definieert.

9. Deeltjes-optische inrichting volgens conclusie 8, waarin een wand van de geul die zich uitstrekt tot het oppervlak van de poolplaat wordt gevormd door een integraal deel van de poolplaat.

10. Deeltjes-optische inrichting volgens een der conclusies 1 - 9, waarin de spoelondersteuning een gesloten ondersteuningsring omvat waarop de spoeldraden zijn gewonden.

11. Deeltjes-optische inrichting volgens een der conclusies 1 - 10, verder omvattend twee lagen van een elektrisch geleidend en niet-magnetisch materiaal gerangschikt tussen de twee poolplaten en zich uitstrekkend aan weerszijden van de straal van geladen deeltjes.

12. Deeltjes-optische inrichting volgens conclusie 11, verder omvattend twee lagen van een elektrisch isolerend materiaal respectievelijk gerangschikt tussen een van de poolplaten en de aanliggende van de lagen van het elektrisch geleidend materiaal.

13. Deeltjes-optische inrichting volgens conclusie 12, waarin elk van de lagen van het elektrisch isolerend materiaal geconfigureerd is als een ondersteuning voor de aanliggende van de lagen van het elektrisch geleidend materiaal.

14. Deeltjes-optische inrichting volgens een der conclusies 1 - 13, verder omvattend ten minste één permanente magneet voor elk van de spoelen.

15. Deeltjes-optische inrichting volgens conclusie 14, waarin een eilandpool is gerangschikt tussen elk van de

permanente magneten en de respectievelijke tegenovergelegen poolplaat.

16. Deeltjes-optische inrichting volgens een der conclusie 14 of 15, waarin het magnetisch veld dat tijdens werking wordt verschaft door de spoelen niet groter is dan het magnetisch veld verschaft door de permanente magneet.

17. Deeltjes-optische inrichting volgens conclusie 16, waarin het magnetisch veld dat tijdens werking wordt verschaft door de spoelen niet groter is dan 10% van het magnetisch veld verschaft door de permanente magneet.

18. Deeltjes-optische inrichting volgens een der conclusies 14 - 17, verder omvattend een regelinrichting voor het compenseren, door middel van de spoelen, van een variatie in tijd van het magnetisch veld dat wordt verschaft door de permanente magneten.

19. Deeltjes-optische inrichting volgens conclusie 18, waarin de regelinrichting een temperatuurmeetinrichting omvat.

20. Deeltjes-optische inrichting volgens een der voorgaande conclusies, waarin de spoeldraden gezamenlijk zijn ommanteld met een elektrisch en thermisch isolerend materiaal, en waarin de poolplaten op een hoger elektrisch potentiaal zijn dan de spoelen.

21. Deeltjes-optische inrichting volgens een der voorgaande conclusies, waarbij de poolplaten gemaakt zijn van een ijzer-nikkel-legering.

22. Deeltjes-optische inrichting volgens een der voorgaande conclusies, waarin de spoelgeulen in de poolplaten zijn gefreesd.

23. Gebruik van de deeltjes-optische inrichting volgens een der voorgaande conclusies voor ten minste een van het deeltjes-optisch belichten of het deeltjes-optisch beeldvormen van een object.

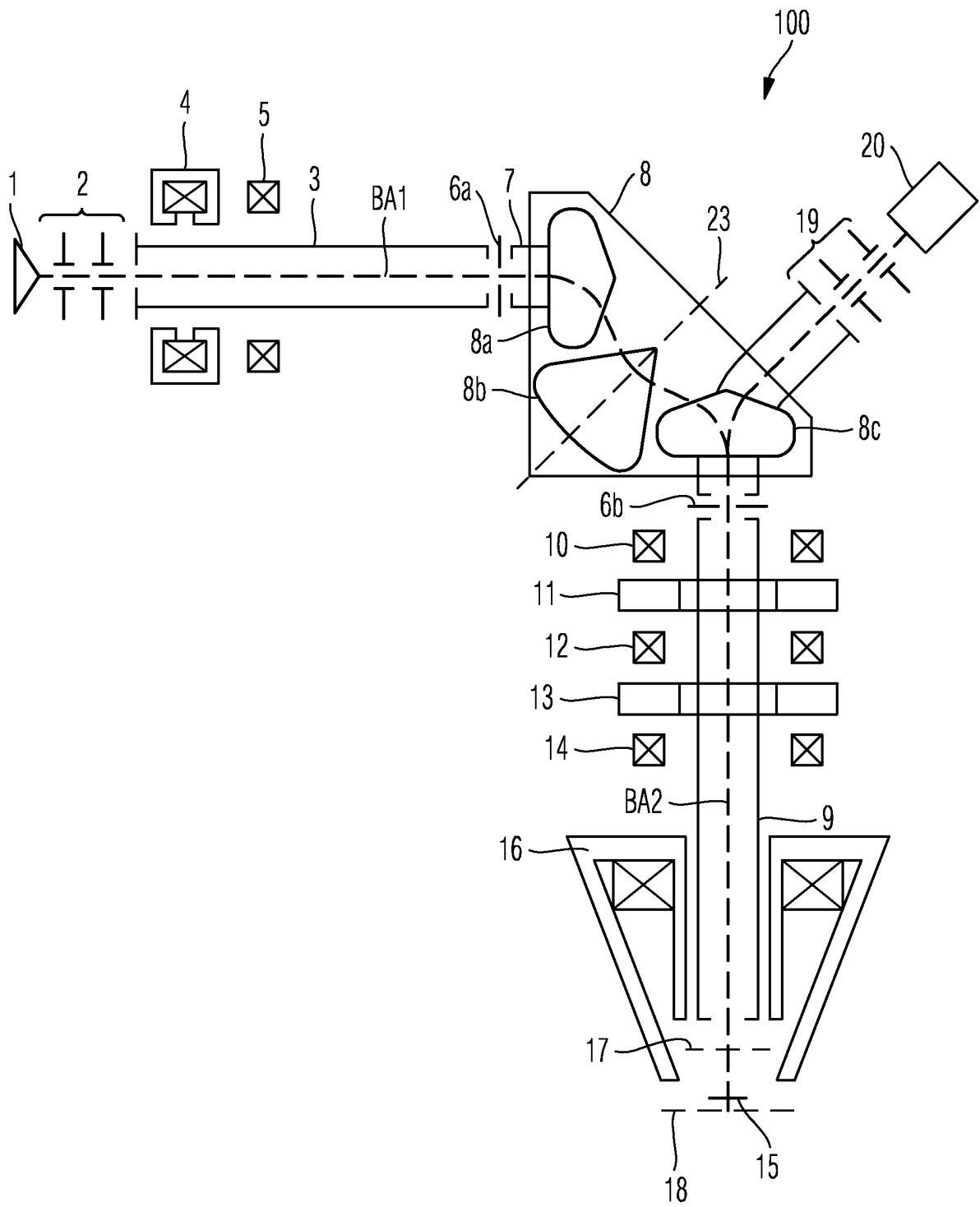

Fig. 1

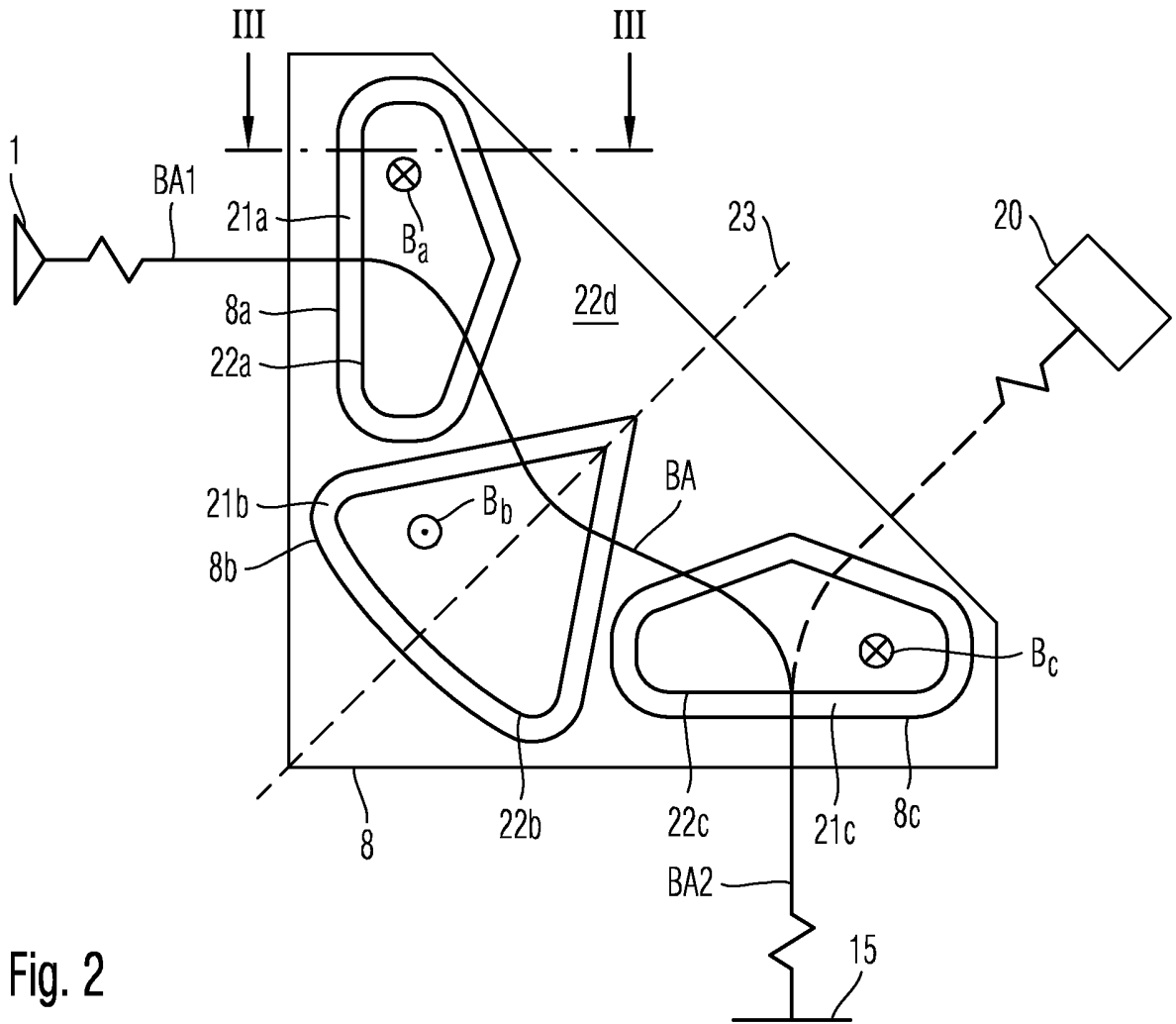

Fig. 2

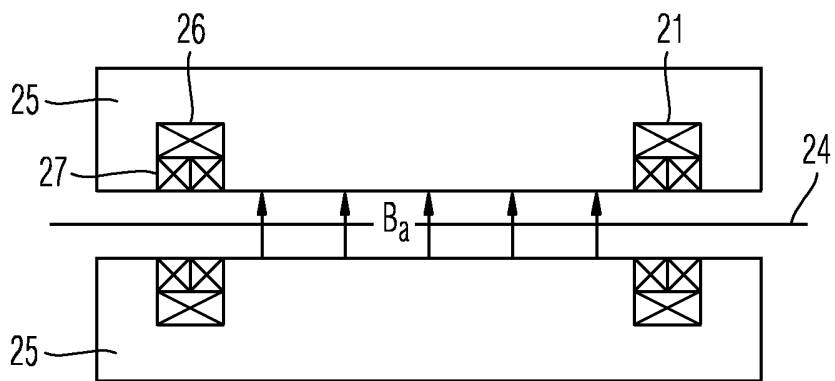

Fig. 3

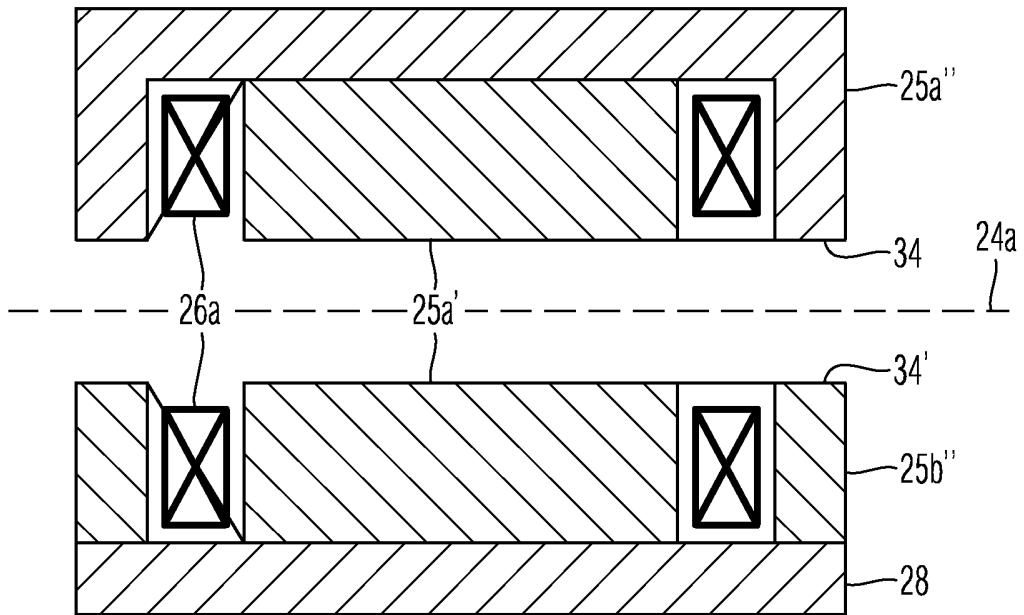

Fig. 4

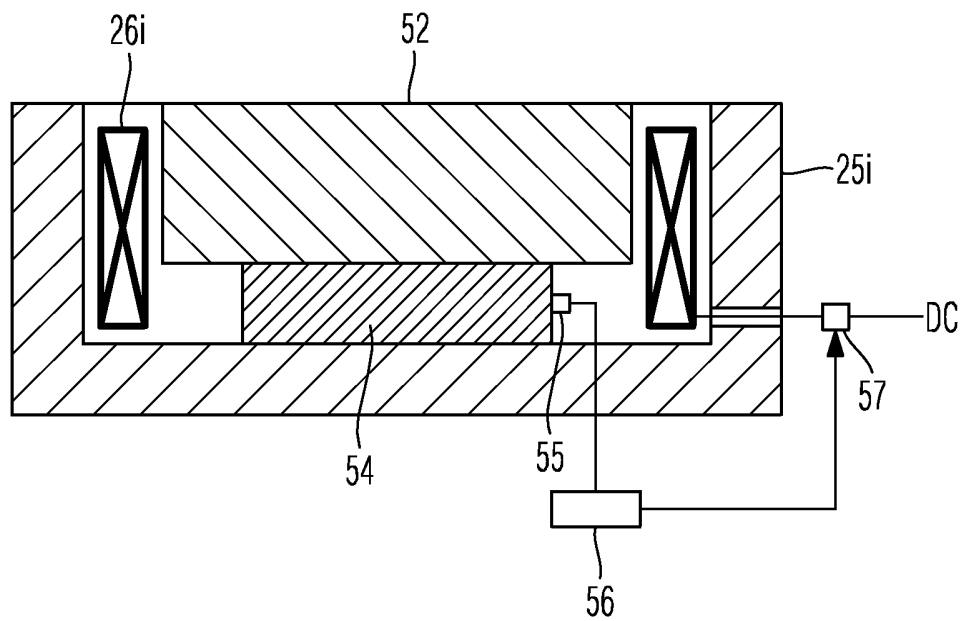

Fig. 9

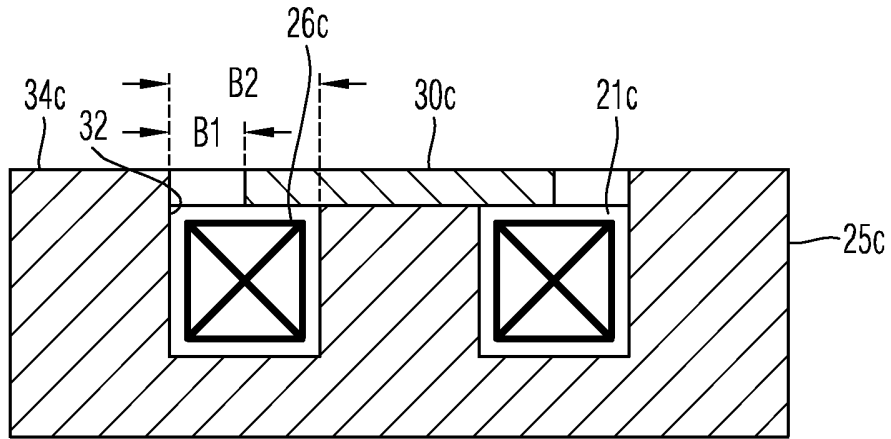

Fig. 5a

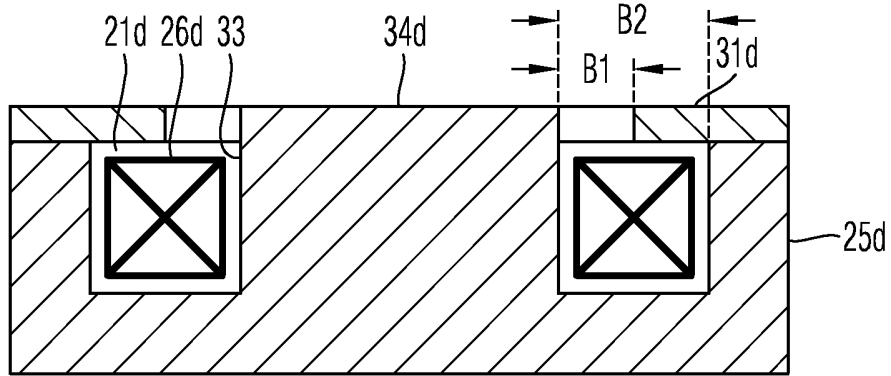

Fig. 5b

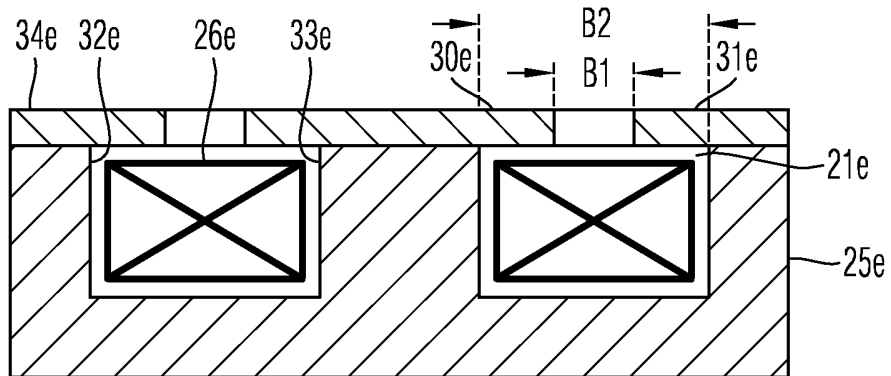

Fig. 5c

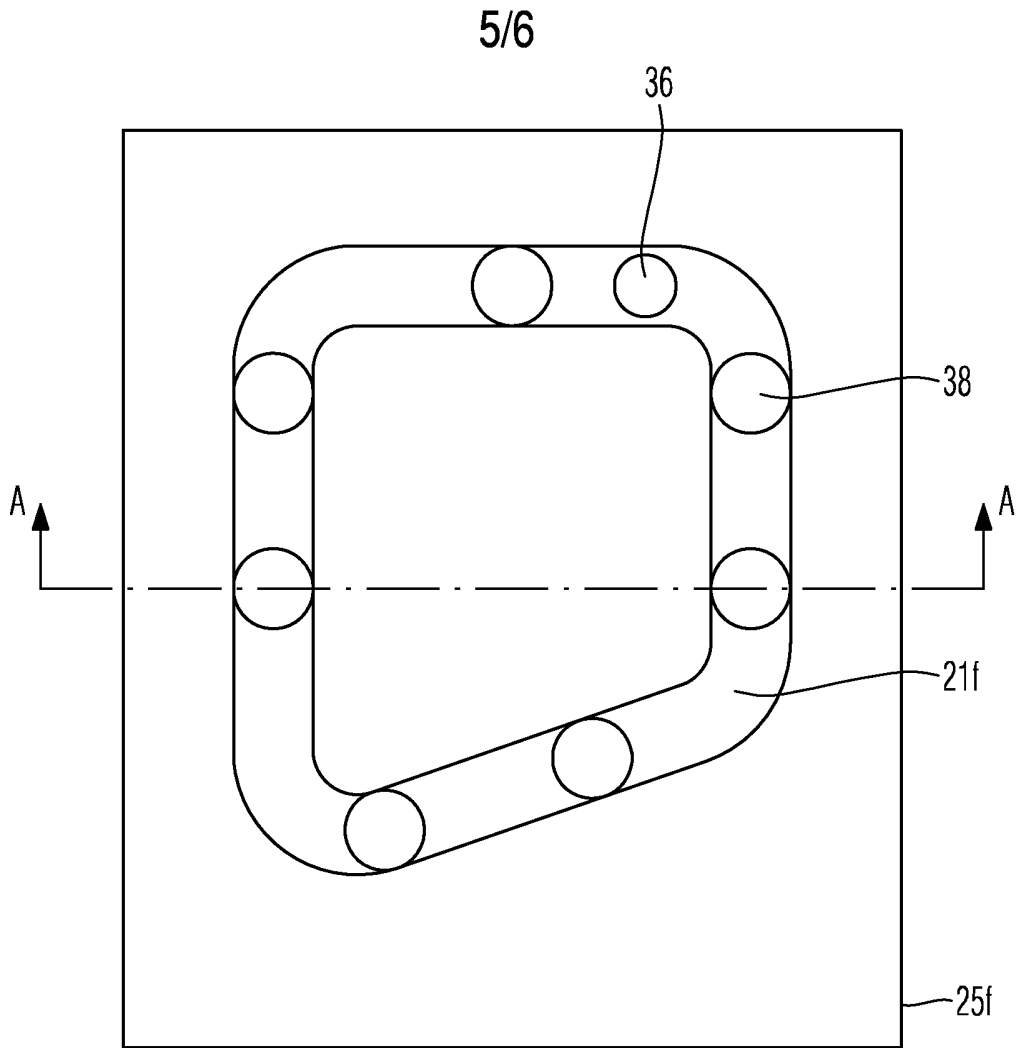

Fig. 6a

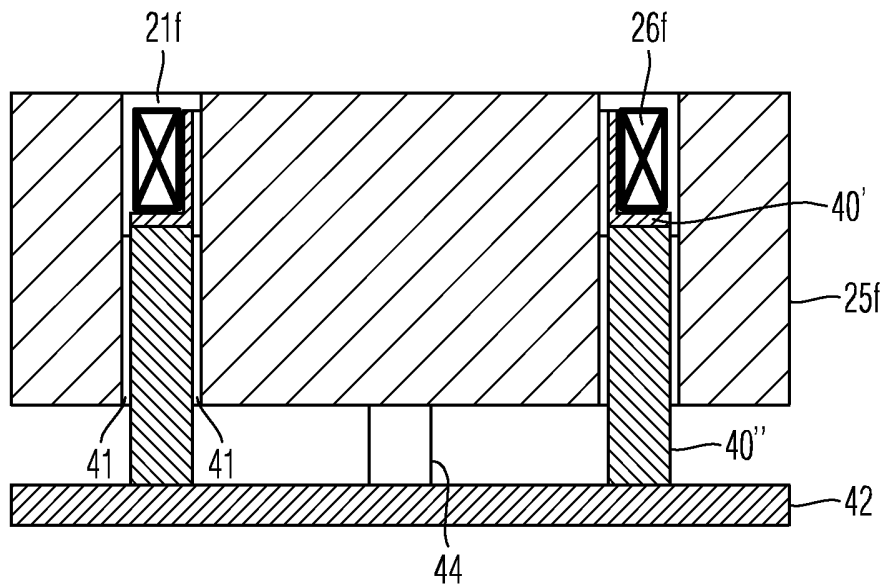

Fig. 6b

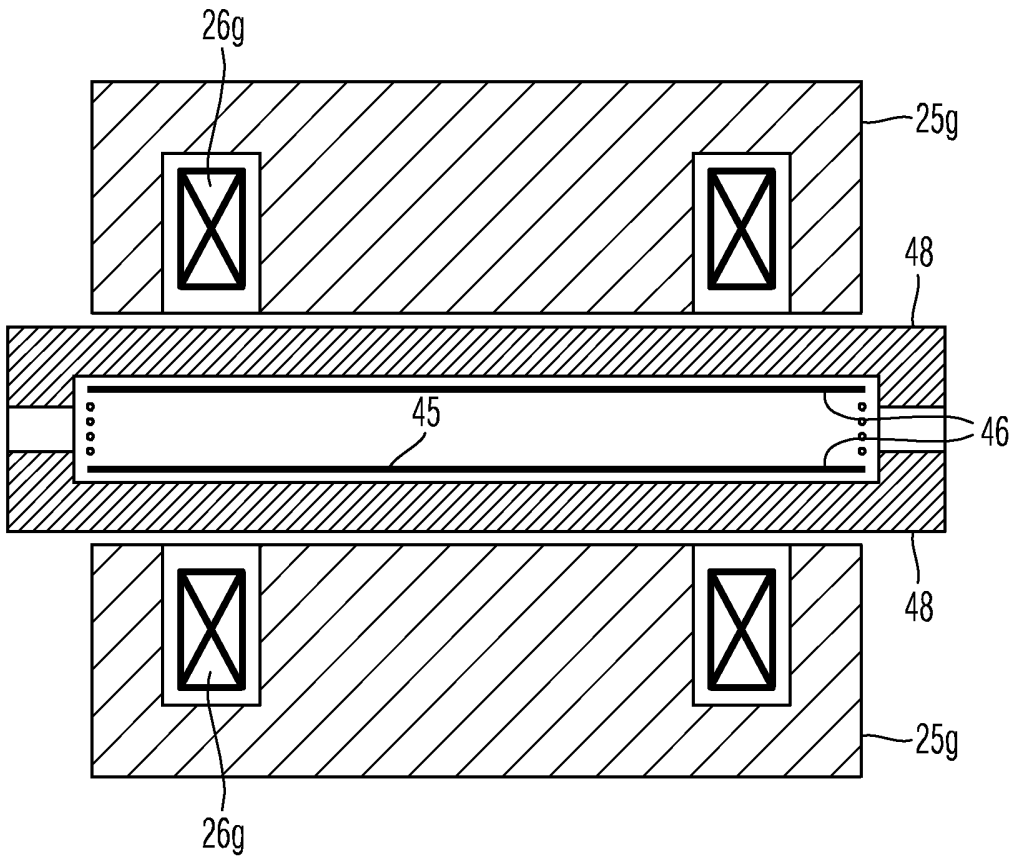

Fig. 7

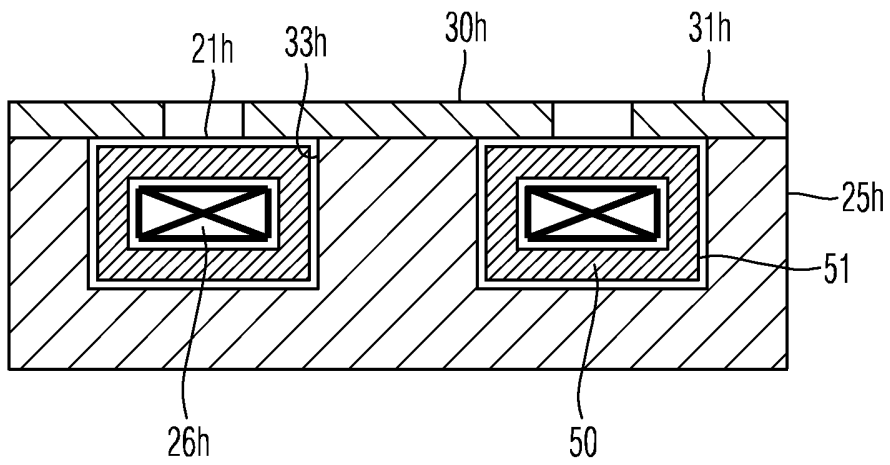

Fig. 8



ONDERZOEKSRAPPORT

BETREFFENDE HET RESULTAAT VAN HET ONDERZOEK NAAR DE STAND VAN DE TECHNIEK

RELEVANTE LITERATUUR			
Categorie ¹	Literatuur met, voor zover nodig, aanduiding van speciaal van belang zijnde tekstgedeelten of figuren.	Van belang voor conclusie(s) nr:	Classificatie (IPC)
X	JP 2007 207467 A (JEOL LTD) 16 augustus 2007 (2007-08-16)	1-8, 25-27	INV. H01J37/147
Y	* samenvatting; figuren *	9-11,23, 24	H01J37/05 G21K1/093
Y	----- WO 2007/060017 A2 (ZEISS CARL SMT AG [DE]; APPLIED MATERIALS ISRAEL LTD [IL]; KNIPPELMEYE) 31 mei 2007 (2007-05-31) * samenvatting; figuren 1,2 * * bladzijde 33, regel 4 - bladzijde 36, regel 8 *	9-11,23, 24	
A	----- US 6 878 937 B1 (MANKOS MARIAN [US]) 12 april 2005 (2005-04-12) * samenvatting; figuren * * kolom 2, regels 39-41 * * kolommen 2-3 *	9-11	
A	----- US 2004/075053 A1 (PREIKSZAS DIRK [DE] ET AL) 22 april 2004 (2004-04-22) * samenvatting; figuren * * alinea's [0060] - [0070] *	9-11	Onderzochte gebieden van de techniek
A	----- US 5 672 879 A (GLAVISH HILTON F [US]) 30 september 1997 (1997-09-30) * het gehele document *	9-11	H01J G21K
Indien gewijzigde conclusies zijn ingediend, heeft dit rapport betrekking op de conclusies ingediend op:			
Plaats van onderzoek: München		Datum waarop het onderzoek werd voltooid: 8 november 2012	Bevoegd ambtenaar: Opitz-Coutureau, J

¹ CATEGORIE VAN DE VERMEDELDE LITERATUUR

X: de conclusie wordt als niet nieuw of niet inventief beschouwd ten opzichte van deze literatuur
Y: de conclusie wordt als niet inventief beschouwd ten opzichte van de combinatie van deze literatuur met andere geciteerde literatuur van dezelfde categorie, waarbij de combinatie voor de vakman voor de hand liggend wordt geacht
A: niet tot de categorie X of Y behorende literatuur die de stand van de techniek beschrijft
O: niet-schriftelijke stand van de techniek
P: tussen de voorrangsdatum en de indieningsdatum gepubliceerde literatuur

T: na de indieningsdatum of de voorrangsdatum gepubliceerde literatuur die niet bezwaard is voor de octrooiaanvraag, maar wordt vermeld ter verheldering van de theorie of het principe dat ten grondslag ligt aan de uitvinding
E: eerdere octrooi(aanvraag), gepubliceerd op of na de indieningsdatum, waarin dezelfde uitvinding wordt beschreven
D: in de octrooiaanvraag vermeld
L: om andere redenen vermelde literatuur
&: lid van dezelfde octrooifamilie of overeenkomstige octrooipublicatie

**AANHANGSEL BEHORENDE BIJ HET RAPPORT BETREFFENDE
HET ONDERZOEK NAAR DE STAND VAN DE TECHNIEK,
UITGEVOERD IN DE OCTROOIAANVRAGE NR.**

NO 137047
NL 2003998

Het aanhangsel bevat een opgave van elders gepubliceerde octrooiaanvragen of octrooien (zogenaamde leden van dezelfde octrooifamilie), die overeenkomen met octrooischriften genoemd in het rapport.

De opgave is samengesteld aan de hand van gegevens uit het computerbestand van het Europees Octrooibureau per De juistheid en volledigheid van deze opgave wordt noch door het Europees Octrooibureau, noch door het Bureau voor de Industriële eigendom gegarandeerd; de gegevens worden verstrekt voor informatiedoeleinden.

08-11-2012

In het rapport genoemd octrooigeschrift		Datum van publicatie	Overeenkomend(e) geschrift(en)	Datum van publicatie
JP 2007207467	A	16-08-2007	JP 4761985 B2 JP 2007207467 A	31-08-2011 16-08-2007

WO 2007060017	A2	31-05-2007	AT 464647 T CN 101379584 A CN 102103966 A CN 102103967 A EP 1966815 A2 EP 2211368 A1 EP 2267753 A2 EP 2267754 A2 EP 2267755 A2 EP 2270835 A2 EP 2270836 A2 JP 2009517816 A KR 20080112189 A US 2009159810 A1 WO 2007060017 A2	15-04-2010 04-03-2009 22-06-2011 22-06-2011 10-09-2008 28-07-2010 29-12-2010 29-12-2010 29-12-2010 05-01-2011 05-01-2011 30-04-2009 24-12-2008 25-06-2009 31-05-2007

US 6878937	B1	12-04-2005	JP 4813063 B2 JP 2005228743 A US 6878937 B1	09-11-2011 25-08-2005 12-04-2005

US 2004075053	A1	22-04-2004	GEEN	

US 5672879	A	30-09-1997	DE 69634125 D1 DE 69634125 T2 EP 0832497 A1 JP 4374400 B2 JP H11507762 A US 5672879 A WO 9642103 A1	03-02-2005 23-06-2005 01-04-1998 02-12-2009 06-07-1999 30-09-1997 27-12-1996



Agentschap NL
Ministerie van Economische Zaken,
Landbouw en Innovatie

SCHRIFTELIJKE OPINIE

DOSSIER NUMMER NO137047	INDIENINGSDATUM 21.12.2009	VOORRANGSDATUM 23.12.2008	AANVRAAGNUMMER NL2003998
CLASSIFICATIE INV. H01J37/147 H01J37/05 G21K1/093			
AANVRAGER Carl Zeiss NTS GmbH			

Deze schriftelijke opinie bevat een toelichting op de volgende onderdelen:

- Onderdeel I Basis van de schriftelijke opinie
- Onderdeel II Voorrang
- Onderdeel III Vaststelling nieuwheid, inventiviteit en industriële toepasbaarheid niet mogelijk
- Onderdeel IV De aanvraag heeft betrekking op meer dan één uitvinding
- Onderdeel V Gemotiveerde verklaring ten aanzien van nieuwheid, inventiviteit en industriële toepasbaarheid
- Onderdeel VI Andere geciteerde documenten
- Onderdeel VII Overige gebreken
- Onderdeel VIII Overige opmerkingen

	DE BEVOEGDE AMBTENAAR Opitz-Coutureau, J
--	---

Onderdeel I Basis van de Schriftelijke Opinie

1. Deze schriftelijke opinie is opgesteld op basis van de meest recente conclusies ingediend voor aanvang van het onderzoek.
2. Met betrekking tot **nucleotide en/of aminozuur sequenties** die genoemd worden in de aanvraag en relevant zijn voor de uitvinding zoals beschreven in de conclusies, is dit onderzoek gedaan op basis van:
 - a. type materiaal:
 - sequentie opsomming
 - tabel met betrekking tot de sequentie lijst
 - b. vorm van het materiaal:
 - op papier
 - in elektronische vorm
 - c. moment van indiening/aanlevering:
 - opgenomen in de aanvraag zoals ingediend
 - samen met de aanvraag elektronisch ingediend
 - later aangeleverd voor het onderzoek
3. In geval er meer dan één versie of kopie van een sequentie opsomming of tabel met betrekking op een sequentie is ingediend of aangeleverd, zijn de benodigde verklaringen ingediend dat de informatie in de latere of additionele kopieën identiek is aan de aanvraag zoals ingediend of niet meer informatie bevatten dan de aanvraag zoals oorspronkelijk werd ingediend.
4. Overige opmerkingen:

Onderdeel III Vaststelling nieuwheid, inventiviteit en industriële toepasbaarheid niet mogelijk

De vraag of de uitvinding in de aanvraag nieuw, inventief en industrieel toepasbaar is, wordt niet behandeld in deze schriftelijke opinie met betrekking tot:

- de gehele aanvraag
- conclusies 12-22

omdat:

- deze aanvraag of deze conclusies , betrekking hebben op materie waarvoor het niet zinvol is een schriftelijke opinie op te stellen.
- de beschrijving, figuren of deze conclusies 12-22, , zo onduidelijk zijn dat het niet zinvol is een schriftelijke opinie op te stellen.

Zie aparte bladzijde

- deze conclusies , onvoldoende steun vinden in de beschrijving waardoor het niet zinvol is een schriftelijke opinie op te stellen.
- geen onderzoek naar de stand van de techniek is uitgevoerd voor deze conclusies .
- een zinvolle schriftelijke opinie niet opgesteld kon worden omdat de sequentie opsomming niet beschikbaar was in het juiste formaat, of in het geheel niet beschikbaar was (WIPO ST25).
- een zinvolle schriftelijke opinie niet opgesteld kon worden zonder de tabellen met betrekking tot de sequentie opsommingen; of deze tabellen waren niet beschikbaar in elektronische vorm.
- Zie aparte bladzijde

Onderdeel V Gemotiveerde verklaring ten aanzien van nieuwheid, inventiviteit en industriële toepasbaarheid

1. Verklaring

Nieuwheid	Ja: Conclusies 9-11, 23, 24 Nee: Conclusies 1-8, 25-27
Inventiviteit	Ja: Conclusies Nee: Conclusies 1-11, 23-27
Industriële toepasbaarheid	Ja: Conclusies 1-11, 23-27 Nee: Conclusies

2. Citaties en toelichting:

Zie aparte bladzijde

SCHRIFTELIJKE OPINIE

Aanvraag nr.:
NL2003998

Onderdeel VII Overige gebreken

De volgende gebreken in de vorm of inhoud van de aanvraag zijn opgemerkt:

Zie aparte bladzijde

Onderdeel VIII Overige opmerkingen

De volgende opmerkingen met betrekking tot de duidelijkheid van de conclusies, beschrijving, en figuren, of met betrekking tot de vraag of de conclusies nawerkbaar zijn, worden gemaakt:

Zie aparte bladzijde

Re Item V

Reasoned statement with regard to novelty, inventive step or industrial applicability; citations and explanations supporting such statement

1 Reference is made to the following documents:

D1 JP 2007 207467 A (JEOL LTD) 16 augustus 2007 (2007-08-16)

D2 WO 2007/060017 A2 (ZEISS CARL SMT AG [DE]; APPLIED MATERIALS ISRAEL LTD [IL]; KNIPPELMEYE) 31 mei 2007 (2007-05-31)

D3 US 6 878 937 B1 (MANKOS MARIAN [US]) 12 april 2005 (2005-04-12)

D4 US 2004/075053 A1 (PREIKSZAS DIRK [DE] ET AL) 22 april 2004 (2004-04-22)

D5 US 5 672 879 A (GLAVISH HILTON F [US]) 30 september 1997 (1997-09-30)

A computer translation of document D1 into English language, which is available on the Internet homepage of the Japanese Patent Office, are annexed to this communication.

2 The present application does not meet the criteria of patentability, because the subject-matter of claim 1 is not new.

D1 discloses

- A particle optical apparatus (D1: abstract, figures), comprising:

a particle source (implicit from D1 since a beam 1 and its trajectory 90 is disclosed) suitable for generating at least one beam (1, 90) of charged particles (abstract, figures; 1, 90);

a magnet arrangement having two pole plates (figures 3-6; see e.g. figure 3: the magnet has upper [45, 41, 44] and lower pole plates [35, 31, 32, 34] with additional upper [93] and lower [83] components and entrance [97] and exit [87] yoke components), which are arranged spaced apart from one another (see the figures), such that the at least one beam (1, 90) of charged particles in operation passes through the pole plates (figures),

wherein trenches (see figures 3, 5, and 6: the free spaces around the coils) are provided in the pole plates,

in which trenches coil wires (see e.g. figure 3: upper coil wires 46 in trenches 48 and 47; lower coil wire 36 in trenches 38 and 37) are arranged,

wherein the trenches (figure 3: 48, 47, 38, 37), when viewed in a cross section (see e.g. figure 3) transverse to an extension direction of the trenches, have a smaller width in a region of a surface of the pole plates, than in a region arranged at a distance from said surface (see figures 3, 5, and 6: since the pole plates are constructed from several components, e.g. upper pole plate in figure 3 consists of left and right outer components 45 and 44 as well as middle component 41, a trench is formed around the coil which is larger at the position of the coils and which is narrower at the beam-side surface of the pole piece.).

Thus, all features of claim 1 are known from D1.

- 3 The present application does not meet the criteria of patentability, because the subject-matter of claim 6 is not new.

D1 discloses

- A particle optical apparatus (D1: abstract, figures), comprising:

a particle source (implicit from D1 since a beam 1 and its trajectory 90 is disclosed) suitable for generating at least one beam (1, 90) of charged particles (abstract, figures; 1, 90);

a magnet arrangement having two pole plates (figures 3-6; see e.g. figure 3: the magnet has upper [45, 41, 44] and lower pole plates [35, 31, 32, 34] with additional upper [93] and lower [83] components and entrance [97] and exit [87] yoke components), which are arranged spaced apart from one another (see the figures), such that the at least one beam (1, 90) of charged particles in operation passes through the pole plates (figures),

wherein trenches (see figures 3, 5, and 6: the free spaces around the coils) are provided in the pole plates,

in which trenches coil wires (see e.g. figure 3: upper coil wires 46 in trenches 48 and 47; lower coil wire 36 in trenches 38 and 37) are arranged, and

a coil support (see e.g. figure 3: the upper [93] and lower [83] plates do support the coils) supporting the coil wires (see e.g. figure 3: upper coil wires 46 in trenches 48 and 47; lower coil wire 36 in trenches 38 and 37),

wherein a gap is provided between the coil support and the pole plate (see figures 3, 5, and 6: a gap is formed around the coils in such a manner that at least a part of the pole plates, see e.g. figure 3 the overhanging part of pole plates 45, 41, and 44 hanging over the coil, is spaced from the coil support 93 by a gap.).

Thus, all features of claim 6 are known from D1.

- 4 The present application does not meet the criteria of patentability, because the subject-matter of claim 27 is not new.

D1 discloses

Use of the particle optical apparatus according to one of the preceding claims for at least one of particle optically illuminating or particle optically imaging an object (D3: abstract, figures; see also the translation of D3 section [Filed of the Invention] paragraphs [0001]-[0004]: the particle optical apparatus of D3 is used in charged particle beam devices, e.g. for inspection and/or processing, such as an electron microscope.).

Thus, all features of claim 27 are known from D1.

- 5 The present application does not meet the criteria of patentability, because the subject-matter of claim 24 does not involve an inventive step, at least as far as claim 24 might be understood - see also the clarity objections against claim 24 under point 10.3.

- 5.1 D1 may be regarded as being the prior art closest to the subject-matter of claim 24, and discloses

- A particle optical apparatus (D1: abstract, figures), comprising:

a particle source (implicit from D1 since a beam 1 and its trajectory 90 is disclosed) suitable for generating at least one beam (1, 90) of charged particles (abstract, figures; 1, 90);

a magnet arrangement having two pole plates (figures 3-6; see e.g. figure 3: the magnet has upper [45, 41, 44] and lower pole plates [35, 31, 32, 34] with additional upper [93] and lower [83] components and entrance [97] and exit [87] yoke components), which are arranged spaced apart from one another (see the figures), such that the at least one beam (1, 90) of charged particles in operation passes through the pole plates (figures),

wherein trenches (see figures 3, 5, and 6: the free spaces around the coils) are provided in the pole plates,

in which trenches coil wires (see e.g. figure 3: upper coil wires 46 in trenches 48 and 47; lower coil wire 36 in trenches 38 and 37) are arranged.

- 5.2 The subject-matter of claim 24 therefore differs from this known particle optical apparatus in that
- a- the coil wires are commonly ensheathed by an electrically and thermally isolating material,
 - b- and wherein the pole plates are at a higher electric potential than the coils.

- 5.3 The problem to be solved by the present invention may therefore be regarded as to
- a- improve the insulation of the coil wires and
 - b- providing additional charged particle beam optical capabilities.
- 5.4 The solution proposed in claim 24 of the present application cannot be considered as involving an inventive step for the following reasons:
- 5.4.1 Providing insulation around the coil wires must be considered as a normal/usual/known design measure for proper functioning of a coil. Therefore, such measure is at least also implicitly known from D1. It is further one of the physical facts known to a person skilled in the art that the common materials used as electrically isolating material at the same time have thermally isolating properties.
- 5.4.2 Furthermore, document D2 discloses a particle optical apparatus (D2: figures 1+2) having a magnet arrangement (figure 2) having pole plates with trenches (figure 2) and coils of coil wires (figure 2). D2 discloses further coil wires (e.g. coil 167) which are commonly ensheathed by an electrically and thermally isolating material (figure 2: insulating resin 170; page 37 line 22 - page 38 line 4). The same passage of D2 also discloses that the pole plates are at a higher electric potential than the coils (figure 2: insulating resin 170; page 37 line 22 - page 38 line 4).
- 5.4.3 Thus, a person skilled in the art of charged particle optics would certainly know the teaching of D2 and would combine this teaching of D2 with the respective teaching of D1 in order to solve the problem posed.

Therefore, the subject-matter of claim 24 does not involve an inventive activity.

- 6 Dependent claims 2-5, 7, 8, 23, 25, 26 do not contain any features which, in combination with the features of any claim to which they refer, meet the requirements of novelty (n) and/or inventive step (is), see the table below:

claim	n/is	reasons
2	n	D1: figures 3, 5, 6: although the figures might not be to scale, it is clear from them that the order of magnitude of the width at a distance from the surface is at least 1.5 times as large as at the surface.
3	n	D1: figures 3, 5, 6: dismountable pole piece

4	n	D1: figures 3 + 5: the outer pole piece parts resemble integral pieces defining the trench wall
5	n	see the reasoning against claim 6 under point 3
7	n	D1: figures 3, 5, 6: a gap is formed around the portion of the coil support area (93) supporting the coil (46)
8	n	D1: figures 3, 5, 6: e.g. figure 3: all the remaining part of the plate 93 (coil support) which is outside the area which supports the coil is regarded as a kind of cooling device since the mass of this part take heat of the coil and conveys it away from the coil, thus functioning as a cooling device.
9, 10	is	D2 discloses a kind of pillar (D2: figure 2: 172, 169) or a plurality of them in order to connect the coil 167 with cooling 171 and excitation power sources. A combination of this teaching with the teaching of D1 appears to be obvious to a skilled person in order to place the coils in good position
11	is	closed rings are well known in the art, e.g. as part of transformers where the coil wires are wound on core rings. Their implementation here appears to be an obvious choice for a skilled person.
25	n	iron-nickel-alloys are well known for their magnetic and (lack of) thermal expansion properties - it appears to be a trivial measure for a person skilled in the art to use such material if necessary
26	n	milling of trenches into plates or milling of steps at plates which are later placed side by side to form a trench is a well known and trivial measure for a skilled person

Re Item VII: Certain defects in the international application (form or content)

- 7 The independent claims are not in the two - part form.
- 8 The features of the claims are not provided with reference signs placed in parentheses.

Re Item VIII: Certain observations on the international application (clarity)

- 9 Although claims 1, 6, 13, 17, and 24 have been drafted as separate independent apparatus claims, they appear to relate effectively to the same subject-matter and to differ from each other only with regard to the definition of the subject-matter for which protection is sought or in respect of the terminology used for the features of that subject-matter. The aforementioned claims therefore lack conciseness.
- 10 Independent claim 13, 17, and 24 are not clear.
- 10.1 Claim 13 is not clear due to misleading wording:
"... two layers of an electrically conductive and nonmagnetic material arranged between the two layers..."
from which it is not clear which material is arranged between the two layers of electrically conductive and nonmagnetic material.
- 10.1.1 Dependent claim 12 contains the same unclear feature and wording as claim 13 and is therefore unclear for the same reasons.
- 10.2 Claim 17 is not clear, since it is not clear for what a permanent magnet may be good for each of the coils.
- 10.2.1 Dependent claim 16 contains the same unclear feature and wording as claim 17 and is therefore unclear for the same reasons.
- 10.3 Claim 24 is not clear, since some of the features in the apparatus claim 24 relate to a method of using the apparatus rather than clearly defining the apparatus in terms of its technical features: the pole plates may only be at a higher potential, when the apparatus is in use and the essential features necessary to provide such potential would be provided, which is not the case at present. Also, this feature cannot distinguish the apparatus, when it is not in use and switched off. The intended limitations are therefore not clear from this claim 24.
- 10.4 The dependent claims 14 to 16 and 18 to 22 depending on unclear independent claims 13 and 17 are thus also unclear.
- 10.4.1 The subject-matter of these unclear claims has not been searched.
- 11 The present application contains 27 claims, of which 6 are independent, 5 of them belonging to the category of apparatus claims.
There is no clear distinction between the 5 independent apparatus claims because of overlapping scope.
There are so many claims, and they are drafted in such a way that the claims

as a whole are not in compliance with the provisions of clarity and conciseness, as it is particularly burdensome for a skilled person to establish the subject-matter for which protection is sought.

The non-compliance with the substantive provisions is to such an extent, that the search was performed taking into consideration the non-compliance in determining the extent of the search.

The search was based on the subject-matter that, as far as can be understood, could reasonably be expected to be claimed later in the procedure, and the corresponding claims, namely claims 1-11 and 23-27.
