

(19) World Intellectual Property Organization
International Bureau



(10) International Publication Number
WO 2010/146499 A1

(43) International Publication Date
23 December 2010 (23.12.2010)

(51) International Patent Classification:
F21V 7/00 (2006.01) F21Y 101/02 (2006.01)
F21K 99/00 (2010.01)

(21) International Application Number:
PCT/IB2010/052559

(22) International Filing Date:
9 June 2010 (09.06.2010)

(25) Filing Language: English

(26) Publication Language: English

(30) Priority Data:
09162852.9 16 June 2009 (16.06.2009) EP

(71) Applicant (for all designated States except US): **KONINKLIJKE PHILIPS ELECTRONICS N.V.** [NL/NL]; Groenewoudseweg 1, NL-5621 BA Eindhoven (NL).

(72) Inventors; and

(75) Inventors/Applicants (for US only): **TUKKER, Teunis, Willem** [NL/NL]; c/o High Tech Campus Building 44, NL-5656 AE Eindhoven (NL). **LENDERIK, Egbert** [NL/NL]; c/o High Tech Campus Building 44, NL-5656 AE Eindhoven (NL). **KURT, Ralph** [DE/NL]; c/o High Tech Campus Building 44, NL-5656 AE Eindhoven (NL).

SPIKES, Mark, Eduard, Johan [NL/NL]; c/o High Tech Campus Building 44, NL-5656 AE Eindhoven (NL).

(74) Agents: **BEKKERS, Joost, J., J.** et al.; High Tech Campus 44, NL-5656 AE Eindhoven (NL).

(81) Designated States (unless otherwise indicated, for every kind of national protection available): AE, AG, AL, AM, AO, AT, AU, AZ, BA, BB, BG, BH, BR, BW, BY, BZ, CA, CH, CL, CN, CO, CR, CU, CZ, DE, DK, DM, DO, DZ, EC, EE, EG, ES, FI, GB, GD, GE, GH, GM, GT, HN, HR, HU, ID, IL, IN, IS, JP, KE, KG, KM, KN, KP, KR, KZ, LA, LC, LK, LR, LS, LT, LU, LY, MA, MD, ME, MG, MK, MN, MW, MX, MY, MZ, NA, NG, NI, NO, NZ, OM, PE, PG, PH, PL, PT, RO, RS, RU, SC, SD, SE, SG, SK, SL, SM, ST, SV, SY, TH, TJ, TM, TN, TR, TT, TZ, UA, UG, US, UZ, VC, VN, ZA, ZM, ZW.

(84) Designated States (unless otherwise indicated, for every kind of regional protection available): ARIPO (BW, GH, GM, KE, LR, LS, MW, MZ, NA, SD, SL, SZ, TZ, UG, ZM, ZW), Eurasian (AM, AZ, BY, KG, KZ, MD, RU, TJ, TM), European (AL, AT, BE, BG, CH, CY, CZ, DE, DK, EE, ES, FI, FR, GB, GR, HR, HU, IE, IS, IT, LT, LU, LV, MC, MK, MT, NL, NO, PL, PT, RO, SE, SI, SK, SM, TR), OAPI (BF, BJ, CF, CG, CI, CM, GA, GN, GQ, GW, ML, MR, NE, SN, TD, TG).

[Continued on next page]

(54) Title: ILLUMINATION SYSTEM FOR SPOT ILLUMINA

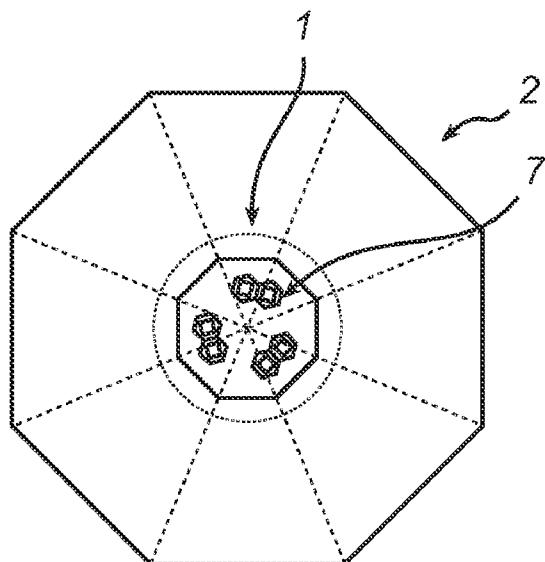

FIG. 2b

(57) Abstract: An illumination system (10) for spot illumination comprising a tubular reflector (2) with a reflective inner surface, the tubular reflector (2) having an entrance aperture (7) and an exit aperture (8) being larger than the entrance aperture (7); and a light source array (1) comprising a plurality of light-sources (13a-c; 30a-d, 31a-d, 32a-d) arranged to emit light into the tubular reflector (2) at the entrance aperture (7) thereof. At least one of the tubular reflector (2) and the light-source array (1) is configured in such a way that each symmetry state of the light-source array (1) is different from any symmetry state of the tubular reflector (2). By avoiding coinciding symmetry states, the occurrence of preferred directions of the emitted light can be reduced, whereby the spatial homogeneity with respect to intensity and, where applicable, color of the emitted light can be improved.



WO 2010/146499 A1

Declarations under Rule 4.17:

— *as to applicant's entitlement to apply for and be granted a patent (Rule 4.17(ii))*

— *before the expiration of the time limit for amending the claims and to be republished in the event of receipt of amendments (Rule 48.2(h))*

Published:

— *with international search report (Art. 21(3))*

Illumination system for spot illumina

TECHNICAL FIELD

The present invention relates to an illumination system for spot illumination, comprising a tubular reflector and a light source array.

5 BACKGROUND OF THE INVENTION

In spot illumination applications, such as scene setting or other atmosphere creating lighting, white light sources with colored filters has been used to a great extent. Lately, as an alternative, illumination systems with colored light sources, such as light emitting diodes, LEDs, have been developed. In systems with colored light sources, the color
10 can be changed by electronic control, and all accessible colors are always available.

In spot illumination applications, the homogeneity of the emitted light is of great importance.

One example of an illumination system for spot illumination is described in US6200002, wherein a tubular collimator collimates light from a light source array arranged
15 in the collimator entrance. Although US6200002 provides for an improved homogeneity compared to the prior art, further improved homogeneity of the emitted light would be desirable.

SUMMARY OF THE INVENTION

20 In view of the above, a general object of the present invention is to provide an improved illumination system for spot illumination providing for an improved homogeneity of the light emitted by the illumination system.

According to a first aspect of the invention, there is provided an illumination system for spot illumination comprising a tubular reflector with a reflective inner surface, the
25 tubular reflector having an entrance aperture and an exit aperture being larger than the entrance aperture; and a light-source array comprising a plurality of light-sources arranged to emit light into the tubular reflector at the entrance aperture thereof, wherein at least one of the light-source array and the tubular reflector is configured in such a way that each

symmetry state of the light-source array is different from any symmetry state of the tubular reflector.

By “symmetry state” should, in the context of the present application, be understood a state, different from an initial state, resulting in the same configuration as the initial state. A symmetry state may be achieved through any kind of transformation, such as rotation, translation, mirroring in respect of a plane, a point or a line, etc.

The present invention is based on the realization that a substantial improvement in the homogeneity of the light emitted by the illumination system can be achieved by configuring at least one of the tubular reflector and the light-source in such a way that there are no coinciding symmetry states of the tubular reflector and the light-source array.

By avoiding coinciding symmetry states, the occurrence of preferred directions of the emitted light can be reduced, whereby the homogeneity, that is, the spatial uniformity with respect to intensity and, where applicable, color of the light output by the illumination system can be improved.

The symmetry states, if any, of the tubular reflector can be controlled through, for example, the physical configuration of the tubular reflector, and the symmetry states, if any, of the light-source array may be controlled through the arrangement of the light-sources comprised in the light-source array.

According to various embodiments, non-coinciding symmetry states of the light-source array and the tubular reflector may be achieved by configuring at least one of the tubular reflector and the light-source array such that it has no symmetry states. For example, the light-sources may be arranged at random, and/or the tubular reflector may have an irregular cross-section.

Alternatively, the tubular reflector may exhibit a first number of states having identical configurations, and the light-source array may exhibit a second number of states having identical configurations, and a ratio between the first number and the second number may be a non-integer. Such a configuration provides for non-coinciding symmetry states.

The number of states having identical configurations equals the initial state plus the number of symmetry states, that is, the number of symmetry states plus one.

By, furthermore, configuring the illumination system in such a way that a largest common divisor of the first number and the second number equals one, the occurrence of preferred directions of the emitted light can be even further reduced, whereby homogeneity of the emitted light can be even further improved.

Moreover, the first number, that is, the number of symmetry states exhibited by the tubular reflector may be a prime number that is greater than two, whereby the more design freedom for the arrangement of the light-sources in the light-source array can be achieved, since fewer light-source configurations will exhibit coinciding symmetry states with such a tubular reflector configuration. According to a preferred embodiment the prime number may be 7.

According to various embodiments, furthermore, at least one of the tubular reflector and the light-source array may exhibit rotational and/or mirror symmetry with respect to an optic axis of the illumination system or a line crossing said optical axis of the illumination system, respectively.

The tubular reflector may have an essentially polygonal cross-section.

By “polygonal cross-section” should, in the context of the present application, be understood a cross-section that is bounded by a closed path of lines connected at at least three points, forming the corners of the polygonal cross-section. The lines can be straight or curved. For example, each path between the corners of the polygon may be concave or convex with respect to the polygonal cross-section. According to a preferred embodiment the polygonal cross section may be septagonal (7 sides) or enneagonal (9 sides).

According to another embodiment the cross section of the tubular reflector may have an essentially circular or elliptical shape.

To further improve the homogeneity of the light emitted by the illumination system, the illumination system may be configured in such a way that the total area of the light-sources comprised in the light-source array may be equal to at least 5% of an area of the entrance aperture of the tubular reflector.

By the total area of the light-sources should be understood the total emissive surface of the light-source, that is, the area that can emit light.

Through the provision of a sufficient ratio between the total emissive area and the area of the entrance aperture, the homogeneity of the light emitted by the illumination system can be improved further. Tests performed by the present inventors have indicated that such a sufficient ratio is around 5% of the area of the entrance aperture of the tubular reflector, and that an even higher ratio yields an even better result. However, the ratio may be preferably equal or at least 10% more preferably equal or at least 15%, and most preferably equal or at least 20%.

According to various embodiments of the present invention, the light-source array may, furthermore, comprise at least one set of light-sources configured to emit light of

a first color and at least one set of light-sources configured to emit light of a second color different from the first color.

A set of light-sources may be a single light-source, or may be a group of light-sources arranged together. For example, a set of light-sources may be provided in the form of
5 a line of light-emitting diodes (LEDs).

Hereby, a color controllable output of light from the illumination system can be provided for.

The present inventors have found that configuring the light-source array in such a way that it comprises at least three sets of light-sources configured to emit light of the first color and at least three sets of light-sources configured to emit light of the second color,
10 is beneficial to the homogeneity of the light output by the illumination system.

Moreover, the light-sources may advantageously be arranged in such a way that the largest spacing between adjacent sets of light-sources is smaller than a third of a lateral extension of the entrance aperture. Hereby, large “dark” areas in the light-source array are avoided, which further improves the homogeneity of the light output by the illumination
15 system. Distributing the light-sources even more uniformly in the light-source array results in a further improvement in the homogeneity.

According to various embodiments, the illumination system according to the present invention may advantageously further comprise a light-diffusing optical member arranged to diffuse light emitted by the illumination system, whereby the homogeneity of the
20 light output by the illumination system can be further improved.

In the illumination system according to the various embodiments of the present invention, the light leaving the tubular reflector at the exit aperture thereof is generally better mixed close to the optic axis of the illumination system than it is further away from the optic axis. Therefore, the light-diffusing optical member may advantageously
25 have a diffusing capability that depends on a distance from an optic axis of the illumination system. In particular, the diffusing capability may advantageously increase with increasing distance from the optic axis of the illumination system.

Moreover, the illumination system may advantageously further comprise a focusing optical element arranged to focus light emitted by the illumination system, whereby
30 the angular spread of the light output by the illumination system can be reduced.

Furthermore, the tubular reflector may be shaped in such a way that a substantially gaussian beam profile is achieved at the exit aperture or in the far field.

The length of the tubular reflector may advantageously range from 3 times the diameter of the entrance aperture to 8 times the diameter of the entrance aperture, and the

ratio between the diameter of the exit aperture and the diameter of the entrance aperture may advantageously range between 3 and 5.

BRIEF DESCRIPTION OF THE DRAWINGS

5 These and other aspects of the present invention will now be described in more detail, with reference to the appended drawings showing an exemplary embodiment of the invention, wherein:

 Fig. 1 is an exploded view of an illumination system according to an embodiment of the present invention;

10 Figs. 2a-b are cross-sectional views as seen along the optic axis illustrating different symmetry relations of exemplary embodiments of the present invention;

 Fig. 3 schematically illustrates an exemplary light-source array configuration; and

 Fig. 4 schematically illustrates an exemplary configuration of the diffusing member comprised in the illumination system in fig 1.

15

DETAILED DESCRIPTION OF AN EMBODIMENT OF THE INVENTION

 In the following description, the present invention is described with reference to an illumination system comprising a light-source array exhibiting a first number of symmetry states and a tubular reflector exhibiting a second number of symmetry states.

20

 It should be noted that this by no means limits the scope of the invention, which is equally applicable to other illumination systems, in which one or both of the light-source array and the tubular reflector may lack symmetry states.

 Fig. 1 schematically illustrates an illumination system for spot illumination suitable for atmosphere creating lighting, such as scene setting. The illumination system 10 comprises a light source array 1 formed by light sources 13a-d, such as LED arrays, mounted on a carrier, such as a printed circuit board (PCB) 3, which is arranged on a heat spreader 4, which is in turn arranged on a heat sink 5. The illumination system 10 further comprises a tubular reflector 2 with a reflective inner surface. The tubular reflector 2 has a light entrance aperture 7, and a light exit aperture 8 being larger than the light entrance aperture 7. At the exit aperture 8 of the tubular reflector 2, a diffusing member, here in the form of an optically diffusing sheet 9 is provided.

25

30

 The light source array 1 is arranged at the entrance aperture 7, to emit light into the tubular reflector 2. In the exemplary embodiment that is schematically illustrated in

fig 1, the tubular reflector 2 has a polygonal cross-section, in a plane perpendicular to the optic axis 12 of the illumination system.

In order to achieve a good homogeneity of the light output by the illumination system 10, the light-source array 1 and the tubular reflector 2 should have no coinciding symmetry states. Two exemplary configurations fulfilling this condition will now be described with reference to figs 2a-b, which are cross-sectional views as seen from the exit aperture 8 of the tubular reflector 2 along the optic axis 12 of the illumination system 10.

In the first exemplary configuration, which is schematically illustrated in fig 2a, the light-source array 1 exhibits one initial state and three symmetry states, that is, additional states resulting in the same configuration as the initial state. In total, the light-source array 1 thus has, as can easily be seen in fig 2a, four states with identical configurations. On the other hand, the tubular reflector 2 in fig 2a has one initial state and four symmetry states, in total five states with identical configurations.

Accordingly, the illumination system configuration that is schematically illustrated in fig 2a does not exhibit any coinciding symmetry states between the light-source array 1 and the tubular reflector 2. In particular, the ratio between the number of states with identical configurations for the tubular reflector 2 and the light-source array 1, respectively, is $5/4 = 1.25$, which is a non-integer.

In the second exemplary configuration, which is schematically illustrated in fig 2b, the light-source array 1 exhibits one initial state and two symmetry states, that is, additional states resulting in the same configuration as the initial state. In total, the light-source array 1 thus has, as can easily be seen in fig 2b, three states with identical configurations. On the other hand, the tubular reflector 2 in fig 2b has one initial state and seven symmetry states, in total eight states with identical configurations.

Accordingly, the illumination system configuration that is schematically illustrated in fig 2b does not exhibit any coinciding symmetry states between the light-source array 1 and the tubular reflector 2. In particular, the ratio between the number of states with identical configurations for the tubular reflector 2 and the light-source array 1, respectively, is $8/3$, which is a non-integer.

In each of the exemplary configurations of the illumination system 10 shown in figs 2a-b, the largest common divisor for the above-mentioned numbers is one.

Fig 3 schematically shows an exemplary configuration of the light-source array 1 comprising a plurality of light-sources in the form of differently colored LEDs. The

light-source array comprises four sets 30a-d of red LEDs arranged in lines, four sets 31a-d of green LEDs arranged in lines and four sets 32a-d of blue LEDs arranged in lines.

As can be seen in fig 3, the light-sources 30a-d, 31a-d and 32a-d are arranged in such a way that the light-source array 1 exhibits rotational symmetry with two states
5 resulting in identical light-source configurations.

To provide for the desired homogeneity of the light output by the illumination system 10 in which the light-source array 1 in fig 3 is comprised, the various sets 30a-d, 31a-d and 32a-d of light-sources are arranged such that the distance between adjacent sets of light-sources with the same color is smaller than one third of a lateral dimension of the
10 entrance aperture 7 of the tubular reflector 2, which is schematically indicated in fig 3.

For the sake of simplicity of illustration, the light-source array 1 in fig 3 has been described as comprising LEDs of three primary colors only. As can readily be appreciated by the person skilled in the art, an improved color mixing and homogeneity can be achieved by providing LEDs configured to emit additional primary colors, such as amber,
15 cyan, deep red and/or deep blue. Alternatively or additionally, various white light-sources may be used, such as warm white, neutral white and/or cool white. Such LEDs may be provided in additional lines, or lines may be provided in which LEDs or two or three colors are alternately arranged.

In the various embodiments of the illumination system according to the
20 present invention, the light output by the illumination system generally becomes less homogeneous with increased distance from the optic axis, in a plane perpendicular to the optic axis.

To further improve the homogeneity of the light output by the illumination system, while keeping the reduction in output efficiency at a minimum, the illumination
25 system 10 may advantageously comprise an optically diffusing member 9 arranged at the exit aperture 8 of the tubular reflector 2. Since the light is generally relatively homogeneous close to the optic axis 12, the light-diffusing member 9 has a lower diffusing capability there than further away from the optic axis 12. This may, for example be achieved by providing a film comprising scattering particles 35, where the concentration of scattering particles increases
30 with increasing distance from the optic axis 12 of the illumination system 10. This is schematically illustrated in fig 4. The optically diffusing member 9 may, alternatively, have a hole in the middle and thus not absorb or scatter any of the light output by the illumination system 10 close to the optic axis 12 thereof. As an alternative or complement to the scattering particles 35 that are schematically shown in fig 4, the diffusing capability of the optically

diffusing member 9 may be accomplished using other means, such as through a holographic pattern and/or a surface relief. It should be noted that the light-diffusing member 9 may advantageously be made of a polymeric material.

5 Additionally, variations to the disclosed embodiments can be understood and effected by the skilled person in practicing the claimed invention, from a study of the drawings, the disclosure, and the appended claims. In the claims, the word "comprising" does not exclude other elements or steps, and the indefinite article "a" or "an" does not exclude a plurality. A single processor or other unit may fulfill the functions of several items recited in the claims. The mere fact that certain measures are recited in mutually different dependent
10 claims does not indicate that a combination of these measured cannot be used to advantage.

CLAIMS:

1. An illumination system (10) for spot illumination comprising:
 - a tubular reflector (2) with a reflective inner surface, said tubular reflector (2) having an entrance aperture (7) and an exit aperture (8) being larger than the entrance aperture (7); and
 - 5 - a light-source array (1) comprising a plurality of light-sources (13a-c; 30a-d, 31a-d, 32a-d) arranged to emit light into the tubular reflector (2) at the entrance aperture (7) thereof,
wherein at least one of said light-source array (1) and said tubular reflector (2) is configured in such a way that each symmetry state of said light-source array (1) is different from any
10 symmetry state of said tubular reflector (2).
2. The illumination system (10) according to claim 1, wherein said tubular reflector (2) exhibits a first number of states having identical configurations, and said light-source array (1) exhibits a second number of states having identical configurations,
15 a ratio between said first number and said second number being a non-integer.
3. The illumination system (10) according to claim 2, wherein a largest common divisor of said first number and said second number equals 1.
- 20 4. The illumination system (10) according to claim 2 or 3, wherein said first number is a prime number greater than 2.
5. The illumination system (10) according to any one of the preceding claims, wherein at least one of said tubular reflector (2) and said light-source array (1) exhibits
25 rotational symmetry with respect to an optic axis (12) of said illumination system (10).
6. The illumination system (10) according to any one of the preceding claims, wherein said tubular reflector (2) has an essentially polygonal cross-section.

7. The illumination system (10) according to any one of the preceding claims, wherein a total area occupied by the light-sources (13a-c; 30a-d, 31a-d, 32a-d) comprised in said light-source array (1) is equal to at least 5% of an area of said entrance aperture (7).

5 8. The illumination system (10) according to any one of the preceding claims, wherein said light-source array (1) comprises at least one set (30ad) of light-sources configured to emit light of a first color and at least one set (31a-d) of light-sources configured to emit light of a second color different from the first color.

10 9. The illumination system (10) according to claim 8, wherein said light-source array (1) comprises at least three sets (30ad) of light-sources configured to emit light of said first color and at least three sets (31a-d) of light-sources configured to emit light of said second color.

15 10. The illumination system (10) according to claim 8 or 9, wherein a largest spacing between neighboring ones of said sets of light-sources is smaller than a third of a lateral extension of said entrance aperture (7).

20 11. The illumination system (10) according to any one of the preceding claims, further comprising a light-diffusing optical member (9) arranged to diffuse light output by said illumination system (10).

25 12. The illumination system according to claim 11, wherein said light-diffusing optical member is configured to exhibit a diffusing capability that depends on a distance from an optic axis of said illumination system.

30 13. The illumination system (10) according to claim 12, wherein said light-diffusing member (9) is configured to exhibit an increasing diffusing capability with increasing distance from said optic axis (12) of the illumination system (10).

14. The illumination system (10) according to any one of the preceding claims, further comprising a focusing optical element arranged to focus light output by said illumination system (10).

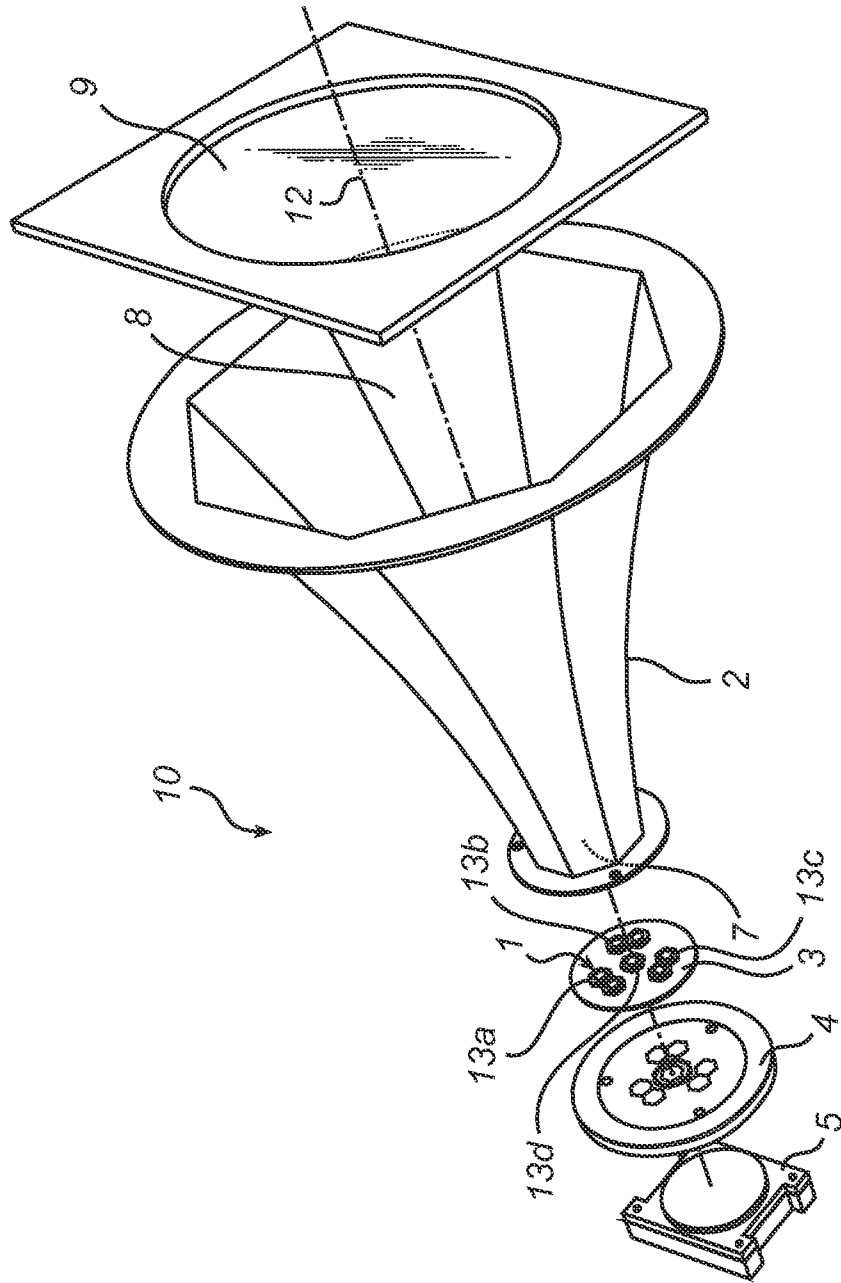

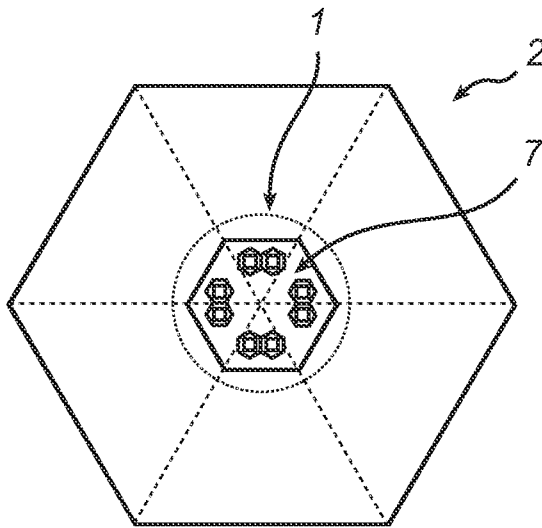

FIG. 2a

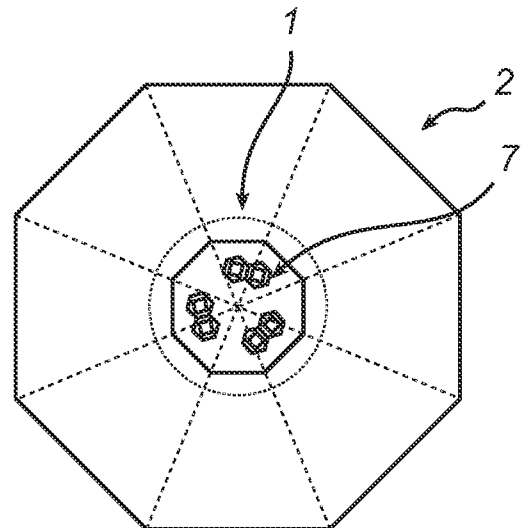

FIG. 2b

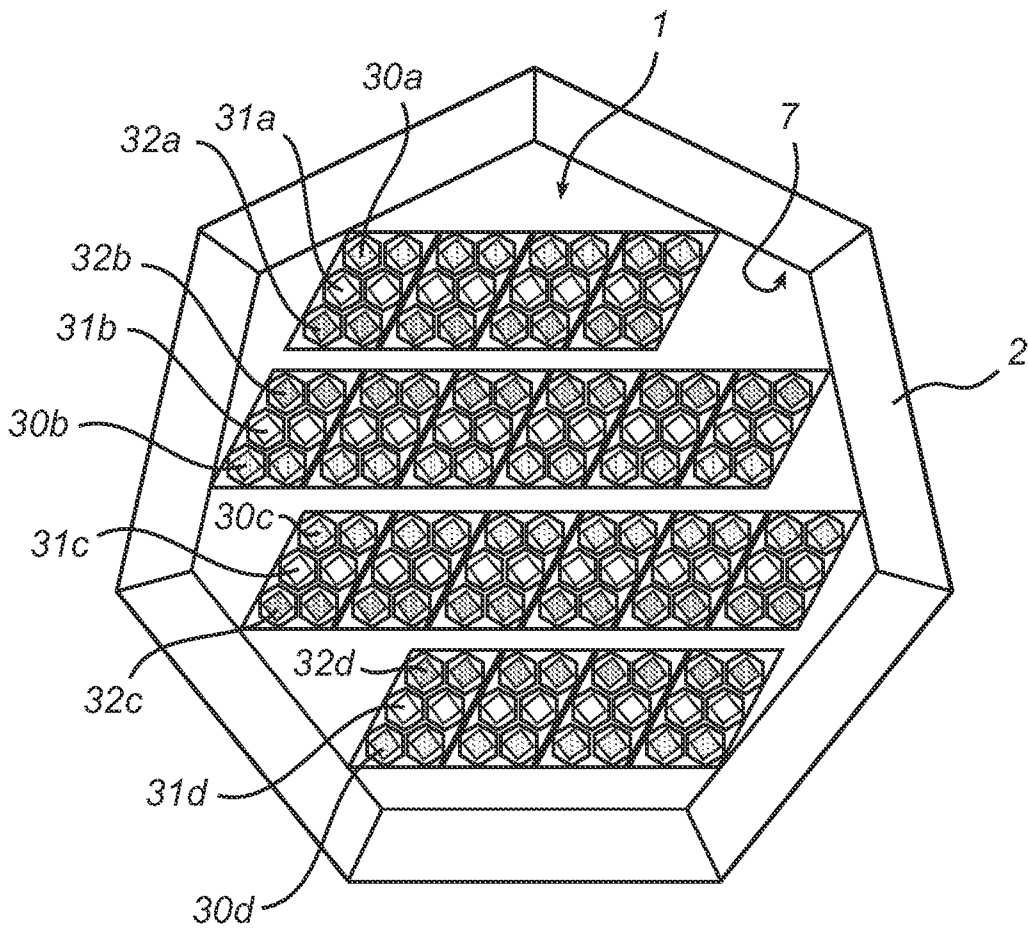

FIG. 3

3/3

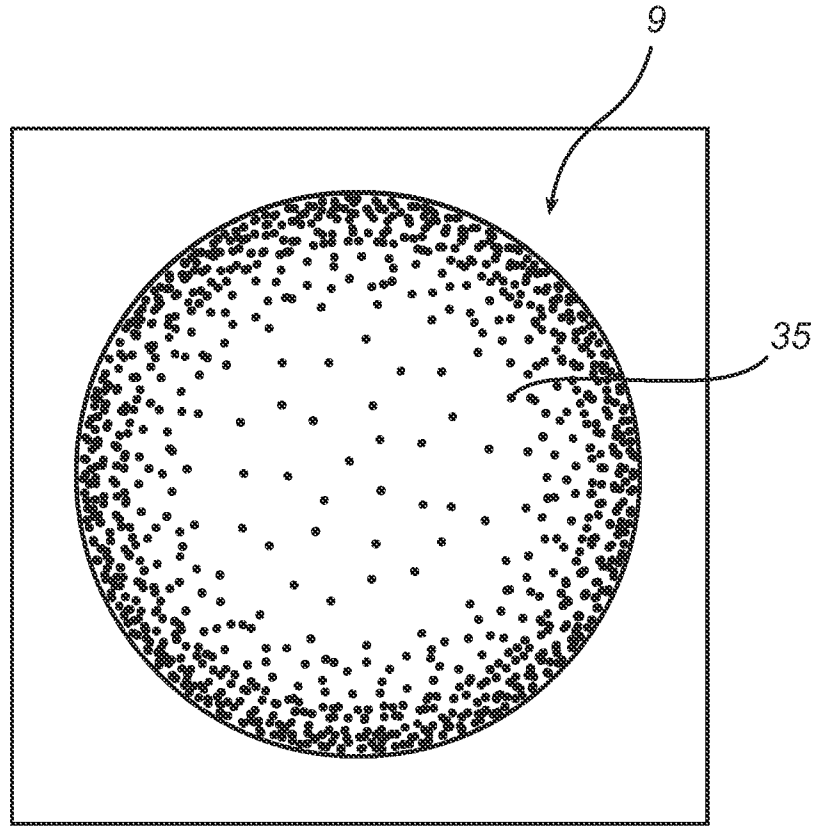

FIG. 4

INTERNATIONAL SEARCH REPORT

International application No
PCT/IB2010/052559

A. CLASSIFICATION OF SUBJECT MATTER
 INV. F21V7/00 F21K99/00
 ADD. F21Y101/02

According to International Patent Classification (IPC) or to both national classification and IPC

B. FIELDS SEARCHED

Minimum documentation searched (classification system followed by classification symbols)
 F21V F21K

Documentation searched other than minimum documentation to the extent that such documents are included in the fields searched

Electronic data base consulted during the international search (name of data base and, where practical, search terms used)
 EPO-Internal

C. DOCUMENTS CONSIDERED TO BE RELEVANT

Category*	Citation of document, with indication, where appropriate, of the relevant passages	Relevant to claim No.
X	US 2005/073244 A1 (CHOU DER JEU [US] ET AL) 7 April 2005 (2005-04-07) paragraph [0029] - paragraph [0078] paragraph [042] figure 10	1-14
X	EP 1 903 274 A1 (SCHEFENACKER VISION SYSTEMS [DE]) 26 March 2008 (2008-03-26) paragraph [0006] - paragraph [0061] figures 1,6,7,9,11	1-14
X	EP 1 693 615 A1 (MODULED INC [TW]; SUN CHING-CHERNG [TW]) 23 August 2006 (2006-08-23) paragraph [0011] - paragraph [0027] figures 2,3,6-11	1-14
	----- -/--	

Further documents are listed in the continuation of Box C. See patent family annex.

* Special categories of cited documents :

"A" document defining the general state of the art which is not considered to be of particular relevance	"T" later document published after the international filing date or priority date and not in conflict with the application but cited to understand the principle or theory underlying the invention
"E" earlier document but published on or after the international filing date	"X" document of particular relevance; the claimed invention cannot be considered novel or cannot be considered to involve an inventive step when the document is taken alone
"L" document which may throw doubts on priority claim(s) or which is cited to establish the publication date of another citation or other special reason (as specified)	"Y" document of particular relevance; the claimed invention cannot be considered to involve an inventive step when the document is combined with one or more other such documents, such combination being obvious to a person skilled in the art.
"O" document referring to an oral disclosure, use, exhibition or other means	"&" document member of the same patent family
"P" document published prior to the international filing date but later than the priority date claimed	

Date of the actual completion of the international search 26 October 2010	Date of mailing of the international search report 02/11/2010
--	--

Name and mailing address of the ISA/ European Patent Office, P.B. 5818 Patentlaan 2 NL - 2280 HV Rijswijk Tel. (+31-70) 340-2040, Fax: (+31-70) 340-3016	Authorized officer Blokland, Russell
--	---

INTERNATIONAL SEARCH REPORT

International application No

PCT/IB2010/052559

C(Continuation). DOCUMENTS CONSIDERED TO BE RELEVANT		
Category*	Citation of document, with indication, where appropriate, of the relevant passages	Relevant to claim No.
X,P	CN 201 368 347 Y (MASS TECHNOLOGY CO LTD [HK]) 23 December 2009 (2009-12-23) figure 1 -----	1-14

INTERNATIONAL SEARCH REPORT

Information on patent family members

International application No
PCT/IB2010/052559

Patent document cited in search report	Publication date	Patent family member(s)	Publication date
US 2005073244 A1	07-04-2005	WO 2005034197 A2	14-04-2005
EP 1903274 A1	26-03-2008	DE 102006044640 A1 US 2008080201 A1	27-03-2008 03-04-2008
EP 1693615 A1	23-08-2006	NONE	
CN 201368347 Y	23-12-2009	NONE	