

(19) **DANMARK**

(10) **DK/EP 3453805 T3**



Patent- og
Varemærkestyrelsen

(12) **Oversættelse af
europæisk patentskrift**

-
- (51) Int.Cl.: **E 03 D 11/08 (2006.01)** **E 03 D 11/13 (2006.01)**
- (45) Oversættelsen bekendtgjort den: **2020-07-20**
- (80) Dato for Den Europæiske Patentmyndigheds bekendtgørelse om meddelelse af patentet: **2020-04-29**
- (86) Europæisk ansøgning nr.: **17190549.0**
- (86) Europæisk indleveringsdag: **2017-09-12**
- (87) Den europæiske ansøgnings publiceringsdag: **2019-03-13**
- (84) Designerede stater: **AL AT BE BG CH CY CZ DE DK EE ES FI FR GB GR HR HU IE IS IT LI LT LU LV MC MK MT NL NO PL PT RO RS SE SI SK SM TR**
- (73) Patenthaver: **Geberit International AG, Schachenstrasse 77, CH-8645 Jona, Schweiz**
- (72) Opfinder: **WEISS, Rolf, Stägacher 2, 8627 Grüningen, Schweiz**
- (74) Fuldmægtig i Danmark: **Chas. Hude A/S, H.C. Andersens Boulevard 33, 1780 København V, Danmark**
- (54) Benævnelse: **Skyllevandsfordeler**
- (56) Fremdragne publikationer:
EP-A1- 2 602 391
WO-A1-2016/184950
DE-A1- 3 315 926

Description

TECHNICAL FIELD

5 The present invention relates to a flush water distributor for an item of sanitary ware according to the preamble to Claim 1.

PRIOR ART

10 In the case of ceramic items of sanitary ware in particular, flush water distributors are used for the improved distribution of flush water in the item of sanitary ware. For example, DE 33 15 926 discloses such a flush water distributor. Three flows of flush water are provided, wherein two of the flows of flush water in each case flow laterally into the toilet bowl, and wherein
15 one of the flows of flush water flows into the toilet bowl in a straight line.

A similar flush water distributor has become known from WO 2016/184950.

The flush water distributors that are known from the prior art suffer from the
20 disadvantage that the flush water is not guided optimally into the toilet bowl. This can lead to flush water overshooting the toilet bowl or to splashing from the toilet bowl. This effect is particularly disadvantageous in the case of so-called rimless toilet bowls.

25 DISCLOSURE OF THE INVENTION

Starting from this prior art, the invention has as its object to propose a flush water distributor which addresses the disadvantages of the prior art. In particular, the flush water distributor is intended to facilitate improved
30 distribution, in particular controlled distribution, of the flush water. An especially preferred object is to enable a central jet of water impinging on the siphon section to be directed more precisely by the flush water distributor.

This object is solved by the device according to claim 1. Accordingly, a flush water distributor for an item of sanitary ware comprises an external wall extending around a central axis, which external wall delimits a pipe section, and a partition wall disposed in the pipe section, which partition wall divides the pipe section into at least one left-hand, one right-hand and one upper distribution section, wherein each of the distribution sections comprises an inlet opening and an outlet opening. In each of the distribution sections, flush water flows in a direction of flow from the inlet opening to the outlet opening. The outlet opening of the left-hand distribution section in the installed position, and viewed in the direction of flow of the flush water, exits from the flush water distributor laterally on the left through the external wall. The outlet opening in this case is configured for spraying a left-hand section of the wall of the item of sanitary ware. The outlet opening of the right-hand distribution section in the installed position, and viewed in the direction of flow of the flush water, exits from the flush water distributor laterally on the right through the external wall. The outlet opening in this case is configured for spraying a right-hand section of the wall of the item of sanitary ware. The outlet opening of the upper distribution section is configured for flushing out the siphon section. The upper distribution section, viewed in the installed position, is disposed above the left-hand and the right-hand section of the distribution section. The outlet openings of the left-hand and the right-hand distribution section, viewed in the direction of flow of the flush water, are located ahead of the outlet opening of the upper distribution section. In other words, this means that the outlet opening of the upper distribution section, viewed in the direction of the central axis, is located further away from the inlet openings than the outlet openings of the left-hand and right-hand distribution section.

This arrangement provides the advantage that the upper distribution section is of longer configuration than the right-hand or the left-hand distribution section. Because of the arrangement of the upper distribution section above the other two distribution sections, the outlet opening of the upper

distribution section is located further away from the inlet opening than the outlet openings of the other two distribution sections. This is applicable in particular for the same size. As a result, it is possible to provide the flush water with a longer path as it flows through, such that the flow calms down in the upper distribution section, whereby the jet of flush water exiting from the upper distribution section can be guided more accurately into the ceramic. The accuracy of the jet of flush water that is directed into the siphon region is of the greatest significance for flushing out the siphon. The precise impingement of the jet of flush water ensures that no splashing occurs. Guiding by the flush water distributor for the jets of flush water spraying the wall of the item of sanitary ware from the left-hand or the right-hand distribution section is less important because in this case the water is guided essentially by the surface of the item of sanitary ware.

In other words, the function can be represented as follows: the left-hand and the right-hand distribution section in the installed position face towards the wall of the item of sanitary ware and flow over the wall in the direction of the siphon of the item of sanitary ware. The water supplied by these two distribution sections essentially cleans the surfaces of the item of sanitary ware. The upper distribution section in the installed position faces towards the siphon region of the item of sanitary ware, as already mentioned, and takes care of flushing out of the siphon region. With regard to this particular jet, it is important for this to be aimed as accurately as possible at the corresponding region. The accuracy of the jet of flush water from the upper distribution section can be considerably improved by the arrangement above the left-hand and the right-hand distribution section.

The outlet opening of the upper distribution section is preferably disposed above the outlet openings of the left-hand and right-hand distribution section.

The total volumetric flow is divided up onto the three distribution sections based on their cross sections. Preferably, precisely three distribution sections are provided. Depending on the function and the distribution of the

flush water, however, it would also be conceivable to provide more than three distribution sections.

5 The outlet opening of the upper distribution section is preferably disposed at the end in relation to the pipe section. The expression “disposed at the end” is used here to denote that the outlet opening is disposed essentially opposite the inlet opening. This arrangement offers the advantage that the outlet opening of the upper distribution section, viewed in the direction of flow, can be disposed further forwards relative to the outlet opening of the right-hand and left-hand distribution section, whereby said extended guide length can be easily implemented.

Depending on the configuration, the upper distribution section, viewed in the installed position, is located preferably exclusively above the central axis. 15 This ensures that the available volumetric flow is divided optimally onto the various distribution sections. If a larger volumetric flow is required in the upper distribution section, this can also extend over the central axis.

A further deflection surface is preferably provided for deflecting the flow of flush water exiting from the upper distribution section in the direction of the siphon region. The deflection surface deflects the flush water from the upper distribution section downwards after the outlet opening. The expression “downwards” is used in this context to denote in the direction of the two other distribution sections or, in the installed state, in the direction of the siphon region of the item of sanitary ware. In a first variant the distribution surface is formed on the flush water distributor, and in a second variant the distribution surface is formed on the item of sanitary ware. 20 25

In the first variant, as already mentioned, the diversion surface is formed on the flush water distributor. The diversion surface formed on the flush water distributor has the advantage that controlled by the upper distribution section after the outlet from the outlet opening can be redirected to the desired point. Because of the integration into the flush water distributor, the 30

diversion can take place independently of the item of sanitary ware, which is an advantage in particular in the case of ceramic items of sanitary ware, because large manufacturing tolerances are likely to be encountered with these.

5

The diversion surface preferably adjoins the external wall.

The deflection surface of both variants preferably extends, viewed transversely in relation to the central axis, essentially inclined at an angle to the central axis. As a result, the water jet exiting from the upper distribution section can be deflected accordingly.

10

The deflection surface of both variants preferably extends completely over the outlet opening of the upper distribution section. The deflection surface preferably extends as a maximum as far as a geometrical enveloping circle, which constitutes the continuation of the pipe section and extends as a minimum as far as the central axis. This arrangement of the deflection surface has the advantage that the longest possible guide is provided for the jet of water from the upper distribution section, which in turn is beneficial for the accuracy of the jet of water into the item of sanitary ware. In the variant according to which the deflection surface is provided by the item of sanitary ware, the deflection surface can also extend further in the direction of the siphon region.

15

20

The deflection surface of both variants is preferably of curved configuration, at least in sections, having a convex curvature.

25

The distance between the inlet opening in the upper distribution section and the deflection surface is preferably greater than the distance between the inlet opening in the left-hand or right-hand distribution section and the outlet opening in the left-hand or right-hand distribution section. This means in turn that the guide length in the distribution section for the upper distribution

30

section is greater than for the left-hand and the right-hand distribution section.

The deflection surface preferably adjoins the pipe section at the front end.

5 This means that the deflection surface protrudes from the pipe section.

The partition wall delimiting the upper distribution section from the left-hand and the right-hand distribution section preferably defines the outlet opening from the upper distribution section with an edge, over which the flush water
10 flows away.

The said edge is located at a distance from the deflection surface, such that the jet of water is able to flow from the upper distribution section through the intermediate space formed between the diversion surface and the edge
15 because of the distance.

The distance between the edge and the diversion surface can be selected such that the cross section through which the water is guided is smaller than or larger than the cross section of the upper distribution section. The velocity
20 of the jet of water can be varied as a result of this.

The distribution sections, viewed from the inlet opening, preferably extend as far as possible towards the outlet opening in a straight line in the direction of the central axis. The longest possible configuration extending in the
25 direction of the central axis offers the advantage that the flow of the flush water into the distribution sections is able to calm down before it is led to the outlet opening.

There is a particular preference for the upper distribution section to extend
30 in a straight line along the central axis for a longer distance than the left-hand and/or the right-hand distribution section. As a result, the flow in the upper distribution section is guided over a longer distance, which is advantageous for its calming in respect of its technical flow properties.

A guide surface, which deflects the distribution section to the respective outlet opening, is preferably arranged respectively in the left-hand and in the right-hand distribution section. A further guide surface, which is disposed in the region of the respective inlet opening, is preferably arranged respectively in the left-hand and the right-hand distribution section. Both guide surfaces offer the technical advantage that a certain degree of guiding is provided for the flow in the respective distribution section.

The guide surfaces are preferably arranged so that the one located in the region of the inlet opening diverts the flow water onto the one in the region of the outlet opening.

The guide surface of the outlet opening preferably deflects the flow through an angle of 30° to 60° in relation to the central axis.

The guide surface is preferably of concave rounded configuration.

The partition wall is preferably located between the left-hand and the right-hand distribution section in a vertical plane. The vertical plane is located in the vertical in the installed position. The left-hand and the right-hand distribution section are preferably configured essentially symmetrically to one another in relation to the partition wall. The upper distribution section is also preferably of essentially symmetrical configuration in relation to the partition wall. This means that the parts of the upper distribution section which are located to the left of the vertical plane are essentially symmetrical to the parts of the upper distribution section, which is located to the right of the vertical plane.

In a first preferred variant, the partition wall is located between the upper distribution section and the left-hand or the right-hand distribution section in a horizontal plane.

In a second preferred variant, the partition wall is located between the upper distribution section and the left-hand or the right-hand distribution section inclined at an angle to the separating wall between the left-hand and the right-hand distribution section.

5

This means that the partition wall, which delimits the upper distribution section in relation to the left-hand and right-hand distribution section, is of V-shaped configuration.

10 The inlet openings are preferably located in a common plane.

The cross section of the left-hand and the right-hand distribution section is preferably identical in size. The cross section of the upper distribution section is equal to, smaller than or greater than the cross section of the left-
15 hand and/or the right-hand distribution section.

The present invention also relates to an item of sanitary ware, in particular a toilet bowl or a urinal, comprising a holder for a flush water distributor, a flush water distributor according to the previous description, together with a
20 wall and a siphon section, wherein the flush water distributor is capable of insertion into the holder in such a way that the upper distribution section is located above the left-hand and the right-hand distribution section.

Further embodiments are indicated in the dependent claims.

25

BRIEF DESCRIPTION OF THE DRAWINGS

Preferred embodiments of the invention are described below on the basis of the drawings, which serve only to provide an explanation and must not be
30 interpreted in a restrictive manner. In the drawings:

- Fig. 1 depicts a perspective view of a flush water distributor in an item of sanitary ware, which is represented in a partially sectioned view;
- Fig. 2 depicts a perspective view of the flush water distributor according to Figure 1 from the rear;
- Fig. 3 depicts a perspective view of a flush water distributor according to Figure 1 from the front;
- Fig. 4a depicts a back view of the flush water distributor according to Figure 1;
- Fig. 4b depicts a sectioned view along the cutting line B-B in Figure 4a; and
- Fig. 4c depicts a sectioned view along the cutting line C-C in Figure 4c.

15

DESCRIPTION OF PREFERRED EMBODIMENTS

Depicted in Figure 1 is a perspective sectional representation of an item of sanitary ware 2, in this case in the form of a toilet bowl, and a flush water distributor 1. The item of sanitary ware 2 can also be a urinal. The flush water distributor 1 serves for the distribution of flush water in the item of sanitary ware 2. The item of sanitary ware 2 typically comprises a wall 15, which leads to a siphon region that is not depicted here.

25

The flush water distributor 1 in this case is inserted into a holder 16 on the item of sanitary ware 2. The flush water distributor 1 in this case is supplied with flush water via a passageway 17 on the item of sanitary ware 2. The passageway 17 in this case is in fluidic communication with a cistern or a similar element.

30

Depicted in Figure 2 is a perspective rear view, and in Figure 3 a perspective front view of the flush water distributor 1.

The flush water distributor 1 comprises an external wall 3 extending around a central axis M. The external wall 3 in this case delimits a pipe section 4, through which the flush water is conveyed. The flush water distributor 1 further comprises a partition wall 5 disposed in the pipe section 4. The partition wall 5 divides the pipe section 4 into at least three distribution sections 6, 7, 8. The partition wall in this case is of essentially T-shaped configuration. A left-hand distribution section 6, a right-hand distribution section 7 and an upper distribution section 8 are provided in the depicted embodiment. The left-hand and the right-hand distribution section 6, 7 are oriented next to each other, and the upper distribution section 8 is located, viewed in the installed position, above the two distribution sections 6, 7. All three distribution sections 6, 7, 8 are oriented in the direction of the central axis M and parallel to one another.

Each of the distribution sections 6, 7, 8 comprises respectively an inlet opening 9 and an outlet opening 10. In each of the flush section 6, 7, 8, flush water is capable of being conveyed in a direction of flow F from the inlet opening 9 to the outlet opening 10. The direction of flow F extends, at least initially, that is to say close to the inlet opening 9, essentially in the direction of the central axis M.

The outlet opening 10 of the left-hand distribution section 6, in the installed position and viewed in the direction of flow F of the flush water, exits from the flush water distributor 1 laterally on the left through the external wall 3. The outlet opening 10 of the left-hand distribution section 6 is configured for spraying a left-hand section of the wall of the item of sanitary ware 2.

The outlet opening 10 of the right-hand distribution section 7, in the installed position and viewed in the direction of flow F of the flush water, exits from the flush water distributor 1 laterally on the right through the external wall 3. The outlet opening 10 of the right-hand distribution section 7 is configured for spraying a right-hand section of the wall of the item of sanitary ware 2.

The wall of the item of sanitary ware 2 is thus essentially sprayed and cleaned via these two outlet openings of the left-hand or the right-hand distribution section 6, 7. The water jet that is led out of these two outlet openings 10 is preferably configured in such a way that the wall of the item
5 of sanitary ware 2 is essentially sprayed completely.

The outlet opening 10 of the upper distribution section 8 is configured for flushing out the siphon section of the item of sanitary ware 2. For this purpose, a corresponding jet is led through the outlet opening 10 in the
10 direction of the siphon region, wherein said jet must impact the siphon region relatively accurately, so that, on the one hand, the siphon region is flushed effectively, and so that, on the other hand, the occurrence of sprays, which spray out of the toilet bowl or the urinal, is avoided.

15 The upper distribution section 8, viewed in the installed position, is disposed above the left-hand and the right-hand distribution section 6, 7. In addition, the outlet openings 10 of the left-hand and the right-hand distribution section 6, 7, viewed in the direction of flow F of the flush water, are disposed ahead
20 of the outlet opening 10 of the upper distribution section 8. This means that the flush water covers a smaller distance in the left-hand and the right-hand distribution sections 6, 7 than in the upper distribution section 8. This has the advantage that the flow in the upper distribution section 8 can be calmed to a greater extent, which is of great importance for the accuracy of the flow jet which exits from the outlet opening 10 of the upper distribution section 8.
25 On the other hand, the flush water from the outlet openings 10 of the left-hand and right-hand distribution section 6, 7 will flow through a shorter guide length, although this is far less critical because of the different function of the corresponding flush water.

30 Depicted in Figure 4b is a sectioned representation along cut line B-B in Figure 4a. It can be clearly appreciated in this case that the guide length in the upper distribution section 8 is greater than the guide length in the left-

hand or in the right-hand distribution section 6 or 7. The guide lengths are marked with the lines F6, 7 and F8.

5 The outlet opening 10 of the upper distribution section 9 is disposed at the end in relation to the pipe section 4. This means that water flows out of the pipe section at the end, whereas the water from the left-hand and the right-hand distribution section 6, 7 flows laterally in relation to the pipe section 4.

10 The flush water distributor 1 further comprises a deflection surface 11, as depicted in the figures. The deflection surface 11 in this case is formed in a single piece on the flush water distributor 1. The deflection surface 11 serves to deflect the flush water of the upper distribution section 8 after the outlet opening 10. In the process, the flush water is deflected from the upper distribution section 8 by the deflection surface 11 appropriately downwards
15 in the direction of the siphon region. In the depicted embodiment, the deflection surface 11 extends inclined at an angle in relation to the central axis M. In addition, it has a slight convexity, as represented in Figure 4b.

20 The deflection surface 11 in this case extends fully over the outlet opening 10 of the upper distribution section 8. The maximum extent of the deflection surface 11 is preferably such that it does not extend beyond a geometrical enveloping circle H, which constitutes the continuation of the pipe section 4. The enveloping circle H is drawn schematically in Figure 4b. However, the deflection surface 11 extends as a minimum over the central axis M, so that
25 the diversion surface 11 also provides an appropriate guide length for the flush water from the upper distribution section 8.

30 The deflection surface 11 in this case adjoins the pipe section 4 at the front end. The outlet opening 10 from the upper distribution section 8 exhibits an edge 13. The edge 13 in this case constitutes a partial limit of the outlet opening 10, and the flush water flows away over the edge 13. The edge 13 in this case is formed by the partition wall 5, which delimits the upper distribution section 8 in relation to the left-hand and the right-hand

distribution section 6, 7. The edge 13 is located at a distance from the deflection surface 11. An intermediate space 18 is created by this distance. The distance between the deflection surface 11 and the edge 13 affords the ability to vary the cross section of the intermediate space 18, whereby optimization of the jet of flush water from the outlet opening 10 of the upper distribution section 8 is facilitated.

It is clear from the figures that the distribution sections 6, 7, 8, viewed from the inlet opening 9, extend as far as possible towards the outlet opening 10 in a straight line in the direction of the central axis M. In this case, in the depicted embodiment, the upper distribution section 8 is configured over a longer distance in a straight line along the central axis M than the left-hand and/or the right-hand distribution section 6, 7. As already mentioned, it is advantageous if the upper distribution section 8 is configured over a longer distance in a straight line than the left-hand and/or the right-hand distribution section 6, 7, because a higher accuracy is required for the flush water directed at the siphon, which is provided from the upper distribution section 8, since it is no longer guided after leaving the guide surface until it impinges on the siphon water, whereas the two lateral jets of flush water flow along the wall of the pan after a short distance.

A guide surface 14, as depicted in Figure 4c, is arranged in the left-hand and in the right-hand distribution section 6, 7. The guide surface 14 in this case is of concave curved configuration and deflects the distribution section 6, 7 to the respective outlet opening 10. As a result, the flush water that is conveyed in the left-hand and the right-hand distribution section 6, 7 is deflected accordingly.

The partition wall 5 between the left-hand and the right-hand distribution section 6, 7 is located in a vertical plane VE, as clearly depicted in Figures 2 and 4a. The partition wall, which delimits the left-hand and the right-hand distribution section 6, 7 from the upper distribution section 8, is illustrated here in an essentially V-shaped configuration. This means that the partition

wall 5 is located with two sections respectively inclined at an angle to the vertical plane VE. The partition wall can also be located in a horizontal plane, however.

5 The left-hand and the right-hand distribution section 6, 7 are configured essentially symmetrically in relation to one another in relation to the partition wall 5 or the vertical plane VE, which lies between these two distribution sections 6, 7. The upper distribution section 8 in relation to the partition wall 5 or the vertical plane VE is likewise of essentially symmetrical configuration.

10

In the depicted embodiment, furthermore, the flush water distributor 1 comprises latching elements 19 disposed in the region of the external wall 3. The latching elements 19 in this case are spring bars, which facilitate the engagement of the flush water distributor 1 in the holder 16 on the item of sanitary ware 2.

15

Furthermore, the flush water distributor 1 comprises alignment elements 20. The alignment elements 20 in this case serve for the alignment of the flush water distributor 1 in the holder 16, and bars protruding from the external wall 3 are thereby provided.

20

In addition, the flush water distributor 1 in the depicted embodiment further comprises an abutment edge 21, which interacts with an abutment 22 in the region of the holder 16 of the item of sanitary ware 2, in such a way that the flush water distributor 1 can be inserted into the holder 16 until it stops.

25

LIST OF REFERENCE DESIGNATIONS

	1	flush water distributor	17	passageway
5	2	item of sanitary ware		18 intermediate space
	3	external wall	19	latch element
	4	pipe section	20	alignment element
	5	partition wall	21	abutment edge
	6	left-hand distribution section	22	abutment
10	7	right-hand distribution section	23	guide surface
	8	upper distribution section		
	9	inlet opening	M	central axis
	10	outlet opening	H	enveloping circle
	11	deflection surface	F	direction of flow
15	12	convex curvature	VE	vertical plane
	13	edge	HE	horizontal plane
	14	guide surface		
	15	wall		
	16	holder		

PATENTKRAV

1. Skyllévandsfordeler (1) til en sanitær artikel (2), såsom en toiletkumme eller et urinal, med en væg (15) og et sifonområde, omfattende
- 5 en ydervæg (3), der strækker sig omkring en midterakse (M), og som afgrænser et rørafsnit (4), samt en skillevæg (5), der er anbragt i rørafsnittet (4), og som opdeler rørafsnittet (4) i mindst et venstre, et højre og et øvre fordelingsafsnit (6,7, 8), hvorved hvert af fordelingsafsnittene (6, 7, 8) omfatter en indgangsåbning (9) og en udgangsåbning (10),
- 10 hvorved, i hvert af skyllévandsafsnittene (6,7, 8), skyllévand strømmer i en strømningsretning (F) for indgangsåbningen (9) til udgangsåbningen (10), hvorved udgangsåbningen (10) for det venstre fordelingsafsnit (6) i installationsposition og set i skyllévandets strømningsretning (F), afgår sideværts til venstre for skyllévandsfordeleren (1), gennem ydervæggen (3) og er konfigureret til at besprøjte et venstre område af den sanitære artikels (2) væg,
- 15 hvorved udgangsåbningen (10) fra det højre fordelingsområde (7) i installationsposition og set i strømningsretningen (F) for skyllévandet, afgår sideværts til højre fra skyllévandsfordeleren (1) gennem ydervæggen (3) og er konfigureret til at besprøjte et højre område af den sanitære artikels væg,
- 20 hvorved udgangsåbningen (10) fra det øvre fordelingsafsnit (8) er udformet med henblik på udskylning af sifonområdet, hvorved det øvre fordelingsafsnit (8), set i installationsposition, er arrangeret oven over det venstre og det højre fordelingsområde (6, 7), og hvorved udgangsåbningerne (10) i det venstre og det højre fordelingsområde
- 25 (6, 7), set i skyllévandets strømningsretning (F), ligger foran udgangsåbningen (10) i det øvre fordelingsafsnit (8).
2. Skyllévandsfordeler (1) ifølge krav 1, **kendetegnet ved, at** udgangsåbningen (10) fra det øvre fordelingsafsnit (8) er arrangeret til frontsiden for rørafsnittet
- 30 (4).
3. Skyllévandsfordeler (1) ifølge krav 1 eller 2, **kendetegnet ved, at** det øvre fordelingsafsnit (8), set i installationsposition, helt ligger oven over midteraksen

(M); eller at det øvre fordelingsafsnit (8), set i installationsposition, strækker sig til neden under midteraksen (M).

4. Skyllévandsfordeler (1) ifølge et af de foregående krav, **kendetegnet ved, at**
5 der på skyllévandsfordeleren (1) desuden er dannet en afbøjningsflade (11), der afbøjer skyllévandet fra det øvre fordelingsafsnit (8) efter udgangsåbningen (10) i retning nedad; eller at udgangsåbningen i det øvre fordelingsafsnit (8) er rettet mod en afbøjningsflade (11), der er dannet på den sanitære artikel.

10 5. Skyllévandsfordeler (1) ifølge krav 4, **kendetegnet ved, at** afbøjningsfladen (11), set på tværs af midteraksen (M), i det væsentlige strækker sig under en vinkel i forhold til midteraksen (M); og/eller
at afbøjningsfladen (11) helt strækker sig over udgangsåbningen (10) i det øvre fordelingsafsnit (8) og med fordel strækker sig maksimalt indtil en geometrisk omslutningscirkel (H), der danner fortsættelsen af rørafsnittet (4) og minimalt strækker sig til midteraksen (M); og/eller
15 **at** afbøjningsfladen (11) mindst områdevist er udformet med en konveks krumning (12);
og/eller
20 **at** afbøjningsfladen (11) ved frontenden slutter sig til rørafsnittet (4).

6. Skyllévandsfordeler (1) ifølge krav 4, **kendetegnet ved, at** afstanden mellem indgangsåbningen (9) i det øvre fordelingsafsnit (8) og afbøjningsfladen (11) er større end afstanden mellem indgangsåbningen (9) i det venstre, henholdsvis
25 højre fordelingsafsnit (6, 7) og udgangsåbningen i det venstre, henholdsvis højre fordelingsafsnit (6, 7).

7. Skyllévandsfordeler (1) ifølge et af de foregående krav, **kendetegnet ved, at** skillevæggen (5), som afgrænser det øvre fordelingsafsnit (8) fra det venstre og
30 det højre fordelingsafsnit (6, 7), begrænser udgangsåbningen (10) med en kant (13), over hvilken skyllévandet bortstrømmer, hvorved kanten (13) fortrinsvis er beliggende i en afstand fra afbøjningsfladen (11).

8. Skyllevandsfordeler (1) ifølge et af de foregående krav, **kendetegnet ved, at** fordelingsafsnittene (6, 7, 8), set fra indgangsåbningen (9), strækker sig så langt som muligt retlinjet hen til udgangsåbningen (10) i retning af midteraksen (11).

5

9. Skyllevandsfordeler (1) ifølge krav 8, **kendetegnet ved, at** det øvre fordelingsafsnit (8) strækker sig over en længere distance retlinjet langs midteraksen (M) end det venstre og/eller det højre fordelingsafsnit (6, 7).

10 10. Skyllevandsfordeler (1) ifølge krav et af de foregående krav, **kendetegnet ved, at** der i henholdsvis det venstre og i det højre fordelingsafsnit (6, 7) er arrangeret en ledeflade (14), som afbøjer fordelingsafsnittet (6, 7) til den respektive udgangsåbning (10), og at der i det venstre og det højre fordelingsafsnit (6, 7) fortrinsvis er arrangeret en yderligere ledeflade (23), som er anbragt i området
15 det ved den respektive indgangsåbning (9).

11. Skyllevandsfordeler (1) ifølge et af de foregående krav, **kendetegnet ved, at** skillevæggen (5) mellem det venstre og det højre fordelingsafsnit (6, 7) ligger i et vertikalplan (VE), hvorved det venstre og det højre fordelingsafsnit (6,7) i
20 forhold til skillevæggen (5), henholdsvis vertikalplanet (VE) i det væsentlige er udformet, så de er dannet symmetrisk i forhold til hinanden, og/eller hvorved det øvre fordelingsafsnit (8) i forhold til skillevæggen (5), henholdsvis vertikalplanet (VE) i det væsentlige er udformet som symmetrisk.

25 12. Skyllevandsfordeler (1) ifølge et af de foregående krav, **kendetegnet ved, at** skillevæggen (5) mellem det øvre fordelingsafsnit (8) og det venstre, henholdsvis det højre fordelingsafsnit (6, 7) ligger i et horisontalt plan (HE); eller
ved, at skillevæggen (5) mellem det øvre fordelingsafsnit (8) og det venstre eller det højre fordelingsafsnit (6, 7) er beliggende under en skrå vinkel i forhold til
30 skillevæggen mellem det venstre og det højre fordelingsafsnit (6, 7).

13. Skyllevandsfordeler (1) ifølge et af de foregående krav, **kendetegnet ved, at** indgangsåbningerne befinder sig i et fælles plan.

14. Skyllévandsfordeler (1) ifølge et af de foregående krav, **kendetegnet ved, at** tværsnittet af det venstre fordelingsafsnit og tværsnittet af det højre fordelingsafsnit er lige store; og/eller at tværsnittet af det øvre fordelingsafsnit er større end eller mindre end eller lig med tværsnittet af det venstre og/eller det højre fordelingsafsnit.

15. Sanitær artikel, navnlig en toiletkumme eller et urinal, omfattende en holder (16) for en skyllévandsfordeler, en skyllévandsfordeler (1) ifølge et af de foregående krav, såvel som en væg (15) og et sifonområde, hvorved skyllévandsfordeleren kan indsættes i holderen på en sådan måde, at det øvre fordelingsafsnit (8) ligger oven over det venstre og det højre fordelingsafsnit (6, 7).

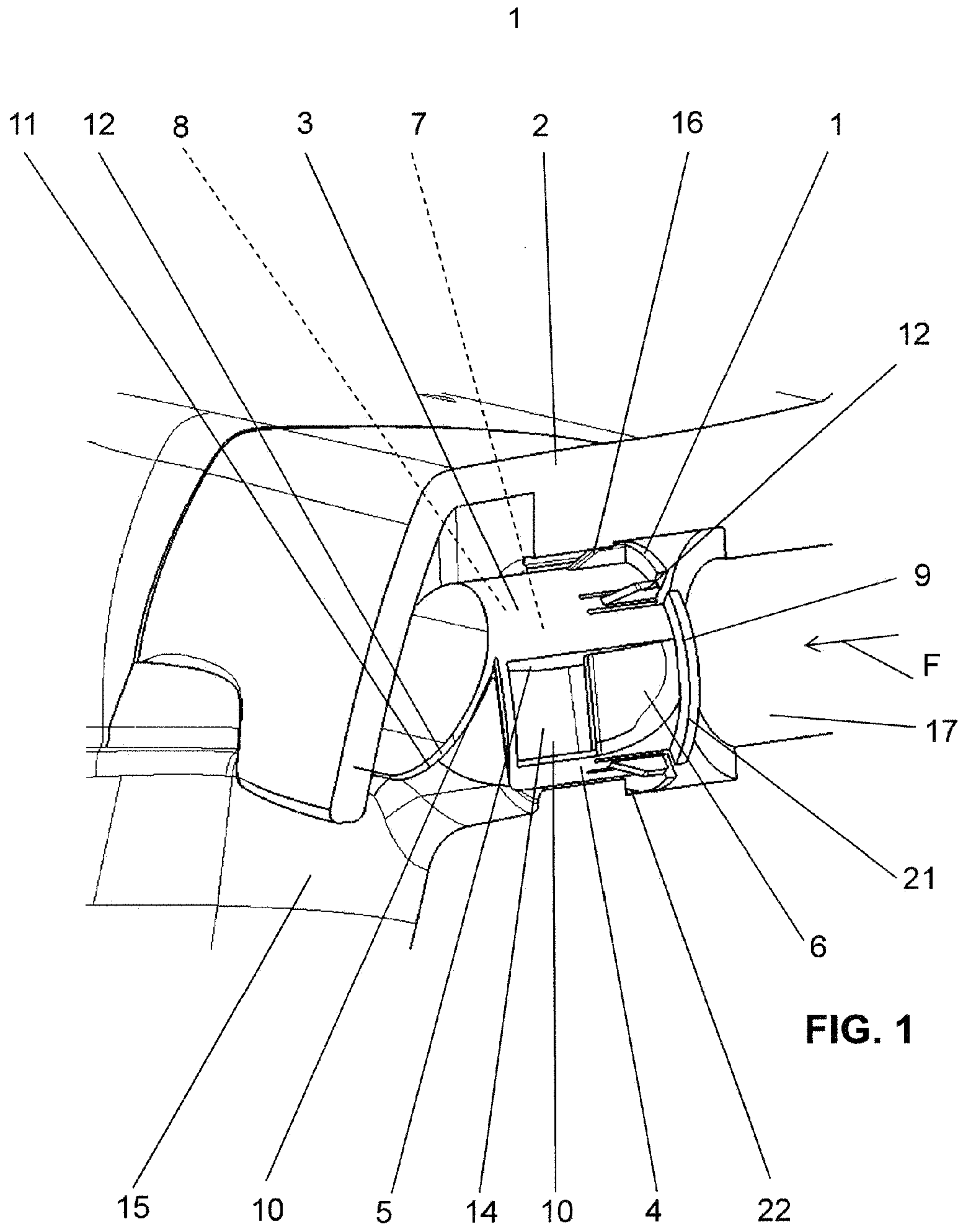

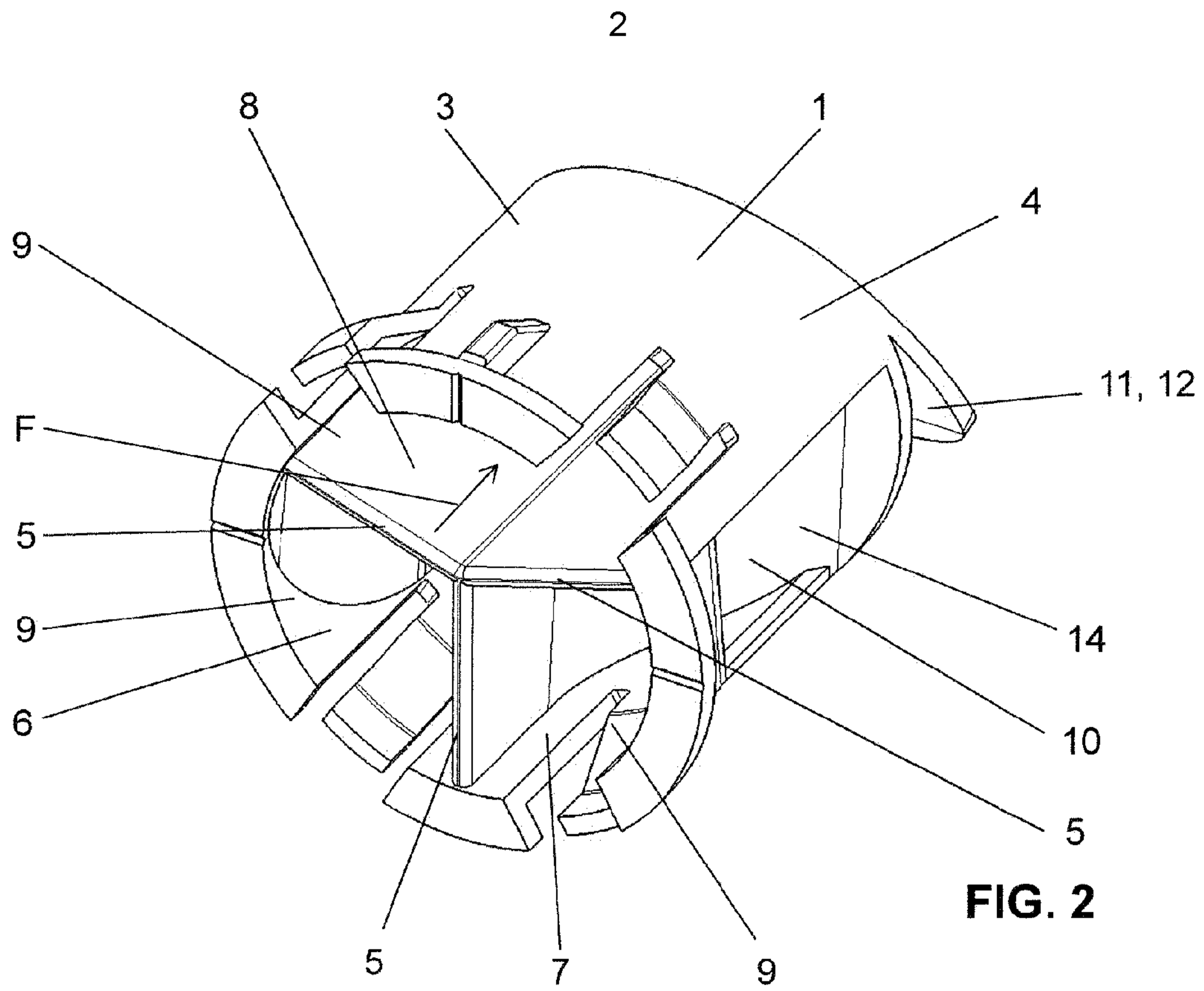

FIG. 2

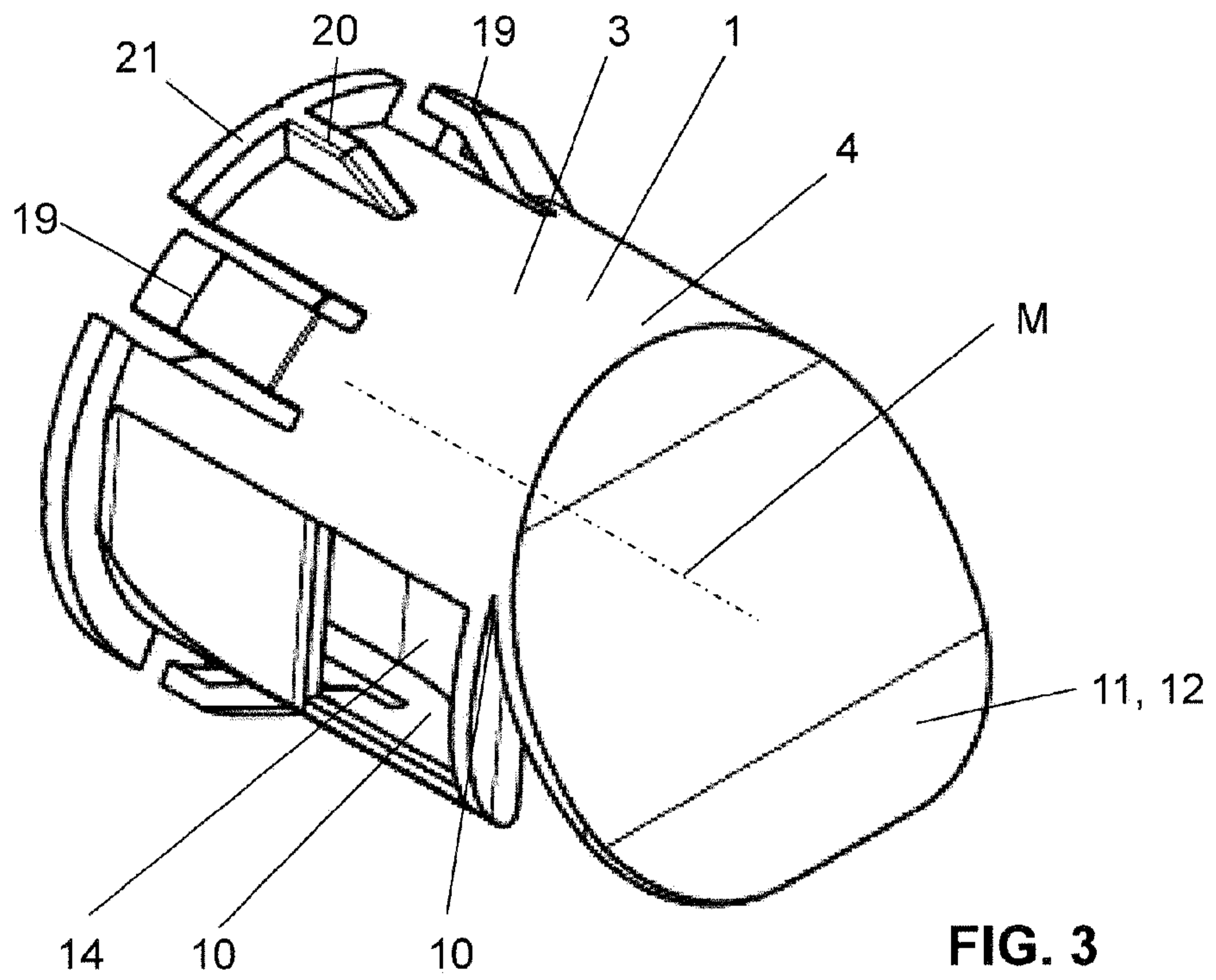

FIG. 3

3

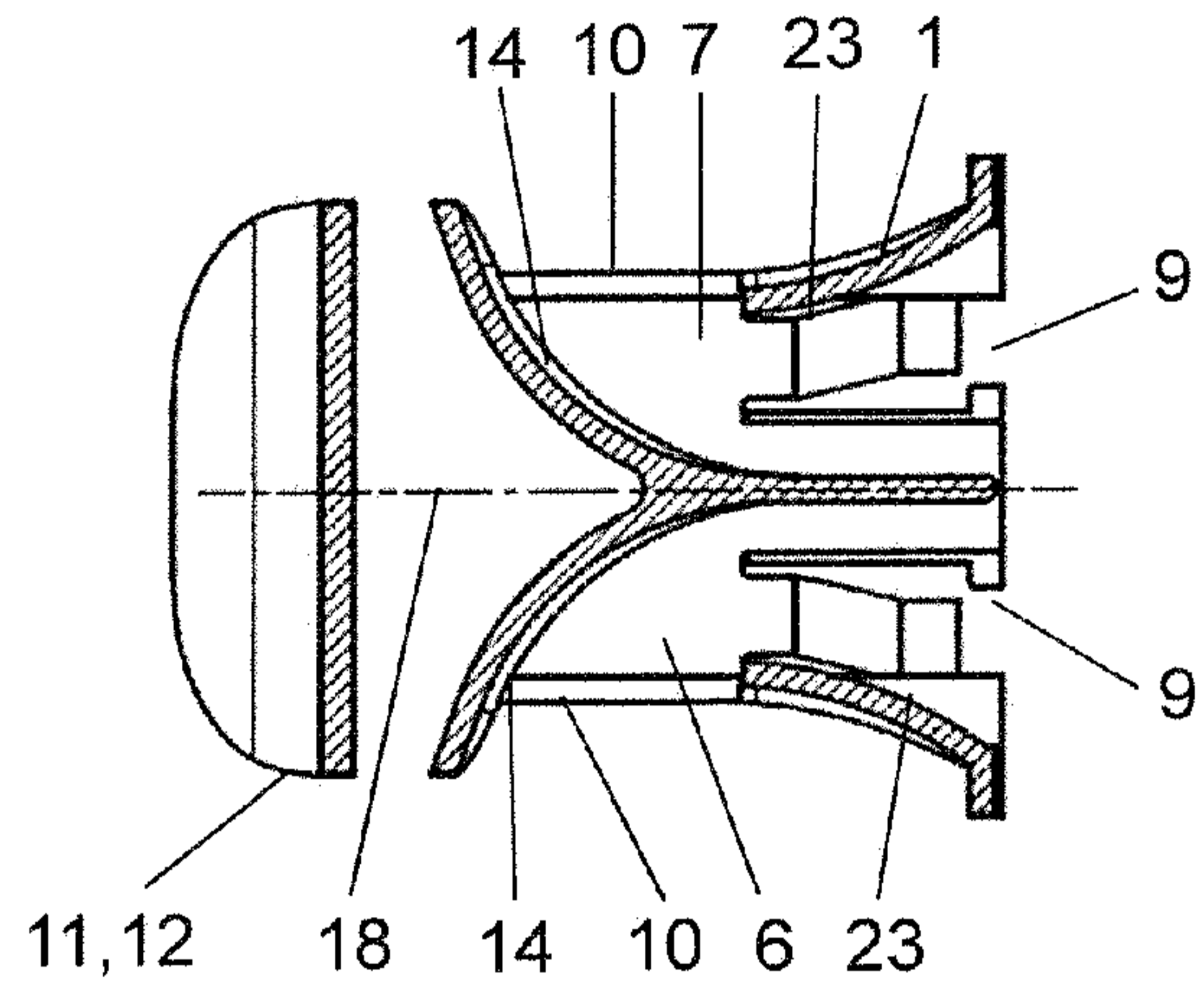
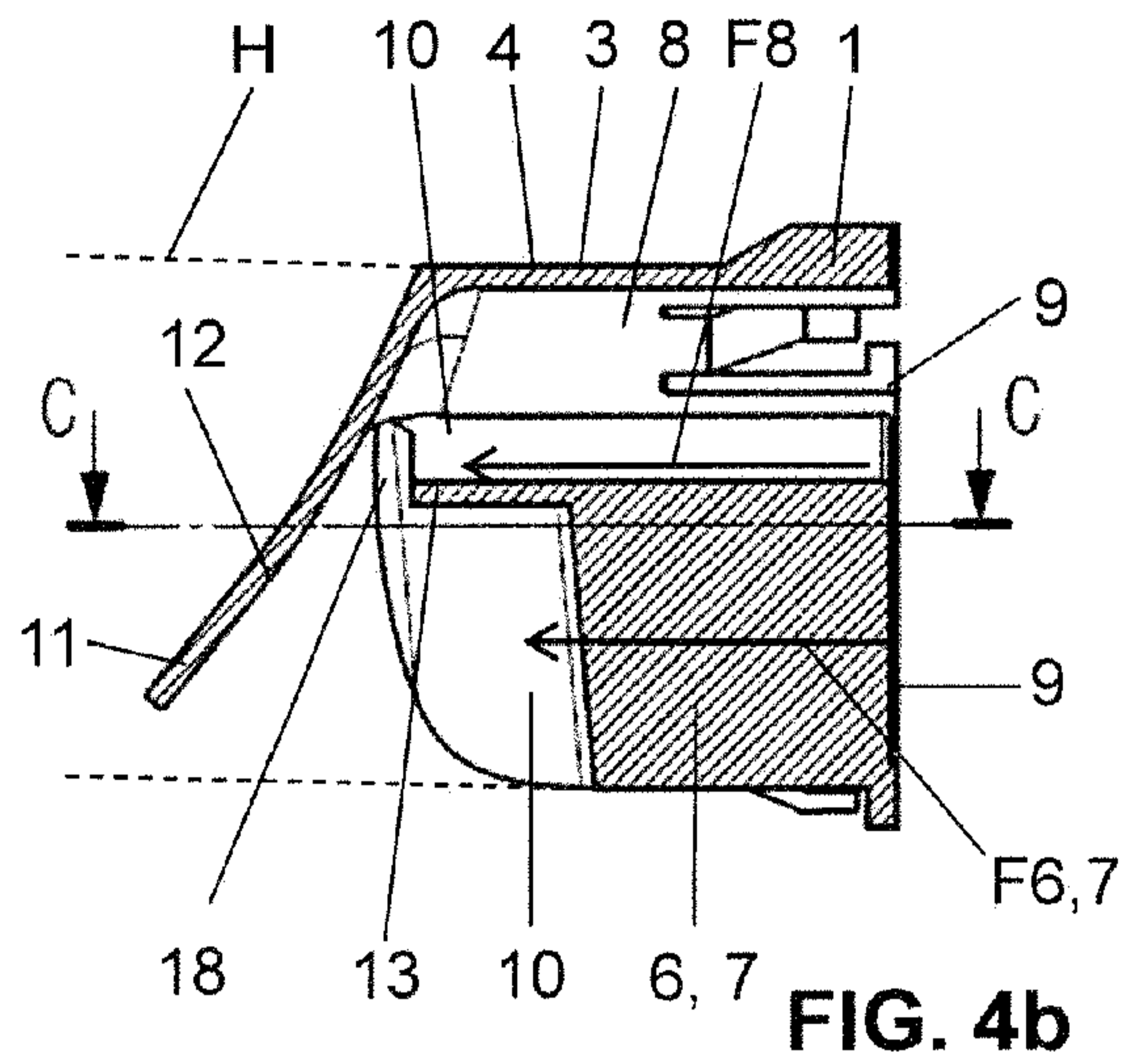
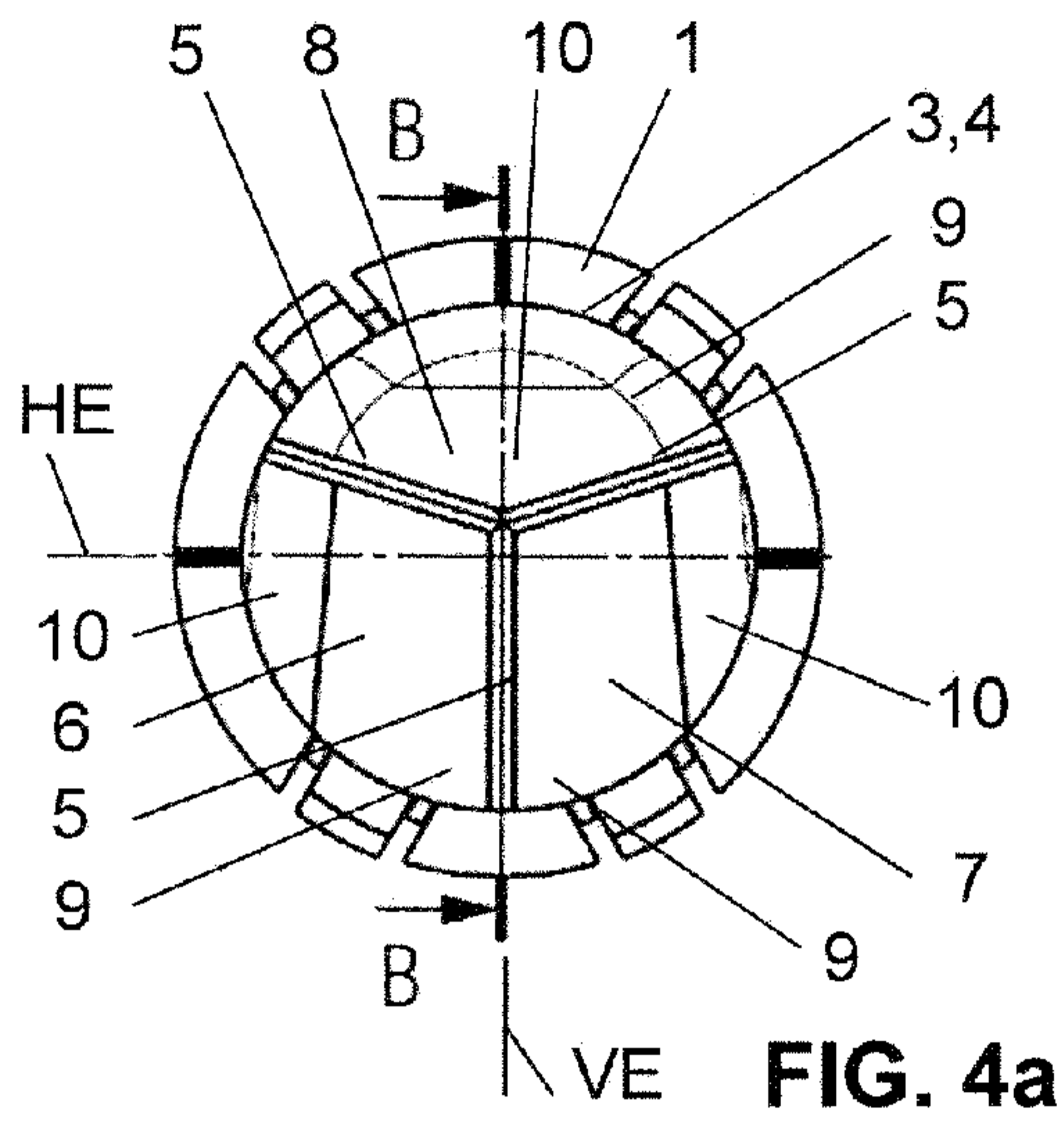

FIG. 4c