

(No Model.)

G. DUPES.  
ROTARY CUTTER FOR PLANING MACHINES.

No. 553,280.

Patented Jan. 21, 1896.

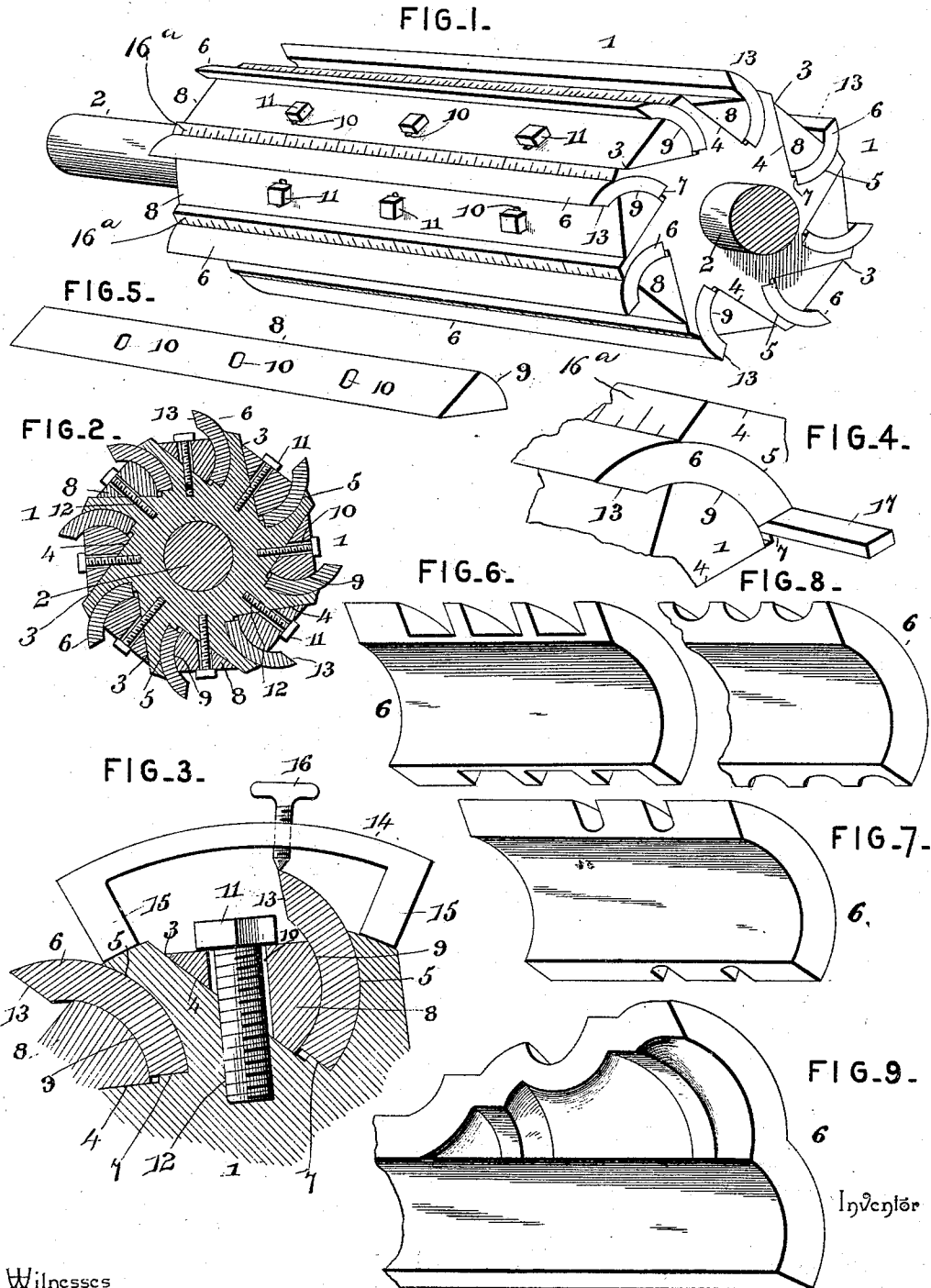

Witnesses  
*Jas. K. McArthur*  
*D. T. McArthur*

By his Attorneys.  
*George Dupes*  
*by C. Snow & Co.*

# UNITED STATES PATENT OFFICE.

GEORGE DUPES, OF SOUTH KNOXVILLE, ASSIGNOR OF ONE-THIRD TO  
T. F. ADAMS, OF KNOXVILLE, TENNESSEE.

## ROTARY CUTTER FOR PLANING-MACHINES.

SPECIFICATION forming part of Letters Patent No. 553,280, dated January 21, 1896.

Application filed February 21, 1895. Serial No. 539,236. (No model.)

*To all whom it may concern:*

Be it known that I, GEORGE DUPES, a citizen of the United States, residing at South Knoxville, in the county of Knox and State of Tennessee, have invented a new and useful Rotary Cutter for Planing-Machines, of which the following is a specification.

This invention relates to rotary cutters for planing-machines; and it has for its object to provide a new and useful cutter of this character that shall provide simple and efficient means for surfacing, jointing, molding, matching, sticking, beading, and all classes of work accomplished by planing-machines.

To this end the main and primary object of the present invention is to provide a construction of cutter-head and certain kind of fastening means for cutter-bits, whereby a great variety of different kinds of cutter-bits can be used on the same head, so that the cutter will be adapted for all kinds of wood-working such as turned out on planing-machines.

With these and other objects in view, which will readily appear as the nature of the invention is better understood, the same consists in the novel construction, combination, and arrangement of parts hereinafter more fully described, illustrated, and claimed.

In the drawings, Figure 1 is a perspective view of a rotary cutter for planing-machines constructed in accordance with this invention. Fig. 2 is a transverse sectional view thereof. Fig. 3 is an enlarged detail transverse sectional view of a section of the cutter, showing in elevation a gage for setting the cutting-edges of the cutter-bits in the same circular path. Fig. 4 is a detail in perspective of a portion of the cutter, showing a different method of setting the cutting-edges of the knives in the same circular path. Fig. 5 is a detail in perspective of one of the fastening-keys. Figs. 6, 7, 8, and 9 are details in perspective of some of the different forms of cutter-bits adapted to be used in connection with the cutter-head.

Referring to the accompanying drawings, 1 designates a cylindrical cutter-head that is made of malleable cast steel, iron, or brass, and is designed to be used in connection with any planer. The cylindrical cutter-head 1 is made in any suitable size, according to the

size of the machine in connection with which the same is used, and is mounted on the usual arbor or shaft 2.

In the present invention the cutter-head 1 is provided in its periphery with a series of longitudinal recesses or pockets 3. The peripheral longitudinal recesses or pockets 3 extend from end to end of the cutter-head and are spaced at regular distances apart and are arranged in any desired number, according to the number of cutter-bits that it is designed for the cutter-head to carry. The said longitudinal recesses or pockets 3 are triangularly or V shaped in cross-section and are provided with the inclined and curved sides 4 and 5, respectively, and the curved sides 5 of said triangular recesses 3 are formed on the arc of the same circle, or, in other words, have the same curvature, which curvature corresponds to the curvature of the transversely-curved cutter-bits 6, that are adapted to be fastened within the recesses 3 against the curved sides 5 of the said recesses. At the bottom angle of the recesses or pockets 3 the cutter-head is provided with the stop-shoulders 7, that form seats for the inner edges of the cutter-bits 6 to rest against, and also form stops to limit the movement of the fastening-keys 8 in one direction.

The fastening-keys 8 are adapted to fit within the recesses 3 and extend from end to end thereof, and are also triangular in cross-section to correspond with the triangular shape of the recesses. The triangularly-shaped fastening-keys 8 have one of their flat sides contact with and slide on the inclined flat sides 4 of the recesses, and said keys are provided opposite their apices with the rounded sides 9, that are adapted to register within and bear against the inner curved sides of the bit 6 to provide for clamping the same tightly against the curved sides 5 of the recesses or pockets. The fastening-keys 8 are provided with a series of transversely-disposed slots 10, that receive the cap-screws 11, engaging in threaded sockets or openings 12, formed in the cutter-head and leading off from the flat inclined sides of the recesses. When the curved cutter-bits have been inserted in place within the recesses 3 between the keys 8 and the curved sides 5 of said recesses, it is simply necessary to tighten the cap-screws, which will cause

55

60

65

70

75

80

85

90

95

100

the keys to slip or slide on the inclined sides 4 of the recesses against the bits 6 to hold the latter firmly in place.

5 The cutter-bits 6 may be of any desired size or shape to provide for planing out different kinds of work; but in all the different forms of bit the same are segmental in cross-section, or transversely curved, in order to register with the curved surfaces 5 and 9, and  
10 in the present invention it is also contemplated that the said bits shall be provided with beveled front edges 13, instead of being beveled on their back or rear sides. By reason of thus beveling the bits the fibers will be  
15 caused to turn short and break, and the fibers or chips will also be caused to pass along the bevel and be thrown clear of the cutter, so as to obviate jamming, as occurs with straight cutter-bits and bits that are beveled on their  
20 back or rear sides with respect to the rotation or travel thereof. In working the cutter-head the bits may or may not extend the entire length of the head, and under certain conditions it may be desirable to remove some of  
25 the bits and operate the cutter with bits located or fastened in only some of the recesses or pockets. In such cases the fastening-keys in the recesses without the bits are jammed, by means of the cap-screws, against the stop-  
30 shoulders 7, in which adjusted positions the said fastened keys will remain firm and steady and will keep the cutter-head perfectly balanced, as will be obvious to those skilled in the art.

35 All of the cutter-bits that are used in connection with the cutter-heads are interchangeable, inasmuch as the same are intended to have a uniform curvature to fit the recesses or pockets of the rotary cutter-head, and some  
40 of the different kinds of cutter-bits are illustrated in Figs. 6, 7, 8 and 9 of the drawings, which show bits for grooving, beading, molding and similar work.

45 Whatever may be the form of cutter-bits employed in connection with the cutter-head, when such bits have become worn, the same may be adjusted outward the proper distance by means of either the gage 14 (shown in Fig. 3) or the gage-strips 17. (Shown in Fig. 4 of the  
50 drawings.) Referring particularly to Fig. 3 of the drawings, the gage 14 is provided with opposite rest-feet 15, that are adapted to rest on the periphery of the head 1 at both sides of a recess or pocket therein, so that the gage  
55 will span such recess or pocket. The proper position of the gage on the head may be determined by adjusting the feet 15 to any graduated point desired, inasmuch as the flat peripheral portions of the cutter-head between  
60 the recesses thereof are provided with inch and fractional graduations 16<sup>a</sup>. The gage 14 carries at a point intermediate of the

feet 15 thereof a gage-screw 16, which may be adjusted down to the cutting-edge of the first cutter-bit that has been adjusted out  
65 when worn, so that each succeeding cutter-bit requires only to be adjusted out to the screw 16, in order to be properly adjusted to cut in the same circular path as the other cutter-bits.

70 Referring to Fig. 4 of the drawings, the outward adjustment or setting of the bits 6 may be secured by placing under the bits, before being fastened, a gage-strip 17 of a certain width, which is removed from under the bit  
75 after being fastened, as will be easily understood. The inch graduations of the periphery on the cutter-head also serve the function of properly setting in the same circular plane narrow cutter-bits—such as bits for  
80 molding, matching, beading, &c.,—so that such bits can be quickly and accurately set to travel precisely in the same path.

85 The many advantages of the herein described rotary cutter will readily suggest themselves to those skilled in the art, and it will be understood that changes in the form, proportion, and the minor details of construction may be resorted to without departing  
90 from the principle or sacrificing any of the advantages of this invention.

Having thus described the invention, what is claimed, and desired to be secured by Letters Patent, is—

95 In a rotary cutter for planers, the cylindrical cutter head provided with a peripheral series of longitudinal V-shaped recesses having separate flat inclined and curved sides respectively, stop shoulders formed in the  
100 bottom angles of said recesses, and graduated flat peripheral portions formed between said recesses and adapted to form rest portions for a gage, curved cutter bits fitted within the recesses against the curved sides thereof, solid triangularly shaped keys having one of  
105 their flat sides slidably contacting with the inclined sides of the recesses, and provided with a series of transversely disposed slots, and rounded sides which register within the concavities of the cutter bits, and cap-screws  
110 passed through the slots of the keys and engaging threaded openings in the cutter head to provide means for wedging the keys against the cutter bits when the latter are in position, or against said stop shoulders when a  
115 bit is removed, substantially as set forth.

In testimony that I claim the foregoing as my own I have hereto affixed my signature in the presence of two witnesses.

GEORGE DUPES.

Witnesses:

J. L. FORD,  
H. H. DAVIS.