

May 9, 1933.

D. J. MORAN ET AL

1,908,627

PIPE LINE PUMP ASSEMBLY

Filed June 22, 1932

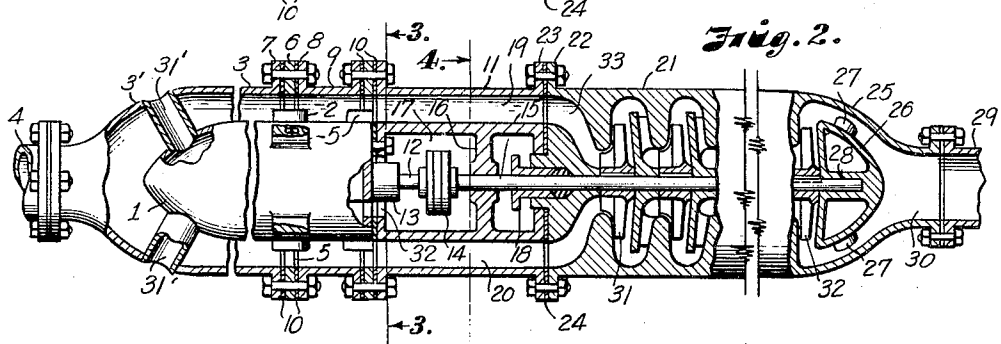
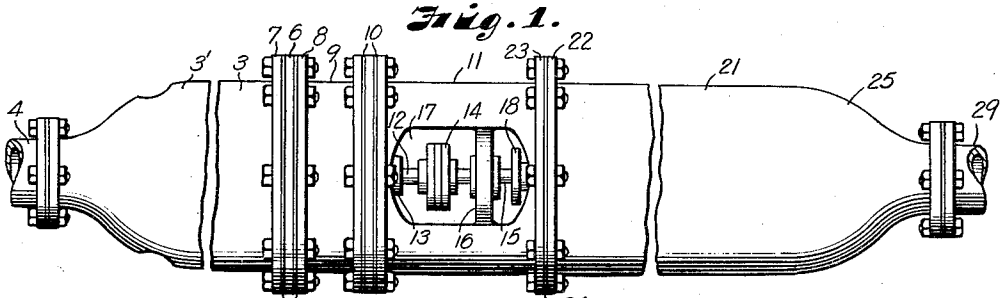

Fig. 3.

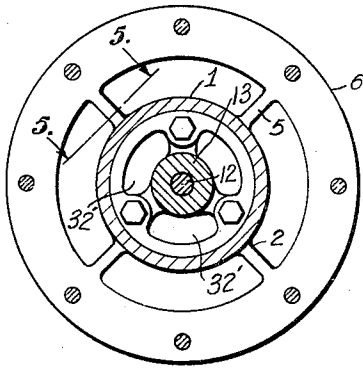

Fig. 4.

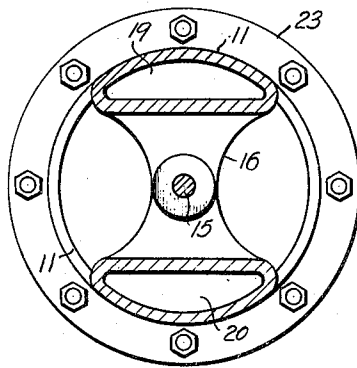
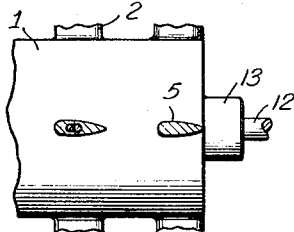

Fig. 5.



INVENTORS  
Daniel J. Moran  
and Edwin O. Bennett  
BY *Thos. E. Scofield*  
ATTORNEY.

# UNITED STATES PATENT OFFICE

DANIEL J. MORAN AND EDWIN O. BENNETT, OF PONCA CITY, OKLAHOMA, ASSIGNORS  
TO CONTINENTAL OIL COMPANY, OF PONCA CITY, OKLAHOMA, A CORPORATION OF  
DELAWARE

## PIPE LINE PUMP ASSEMBLY

Application filed June 22, 1932. Serial No. 618,793.

Our invention relates to pipe line pump assemblies and more particularly to a booster pump assembly adapted to be placed in a pipe line for transporting oil.

5 In long oil pipe lines, it is necessary to install booster pumps at suitable intervals. The present practice is to use Diesel or motor-driven units housed in small buildings or placed upon suitable foundations. In the  
10 large pipe lines, the expense of building foundations for housing is considerable.

One object of our invention is to provide a booster pump assembly for oil pipe lines which may be assembled between flanges in a  
15 pipe line.

A further object of our invention is to provide a booster pump assembly which will require no exterior support or foundation.

20 Still another object of our invention is to provide a booster pump assembly which may be placed in a ditch or pit or on the surface of the ground in alignment with the pipe line requiring but little space.

25 Still another object of our invention is to provide an assembly which may be quickly installed and will effect a great saving in the cost of building booster units over a booster unit of the conventional type of like capacity.

30 Another object of our invention is to provide an electrically driven pipe line pumping unit in combination with our novel assembly in which the motor is cooled by contact with the fluid pumped.

35 In the accompanying drawing in which like reference numerals are used to indicate like parts in the various views and which form part of the instant specification and are to be read in conjunction therewith:

40 Figure 1 is a side elevation of a booster pump assembly embodying one mode of carrying out our invention.

Figure 2 is a sectional view of the embodiment shown in Figure 1.

45 Figure 3 is a sectional view taken on the line 3-3 of Figure 2.

Figure 4 is a sectional view taken on the line 4-4 of Figure 2.

Figure 5 is a fragmentary sectional view taken on the line 5-5 of Figure 3.

50 In general our invention consists of an elec-

trically driven motor directly connected with a multistage pump of any suitable type through a flexible coupling. The motor is housed in a casing and supported therefrom in any suitable manner by means of a spider. 55 The motor is completely enclosed in a streamlined housing around which the stream of fluid being pumped is adapted to flow, thus effecting a cooling of the motor. A section joins the motor section with the pump section and is provided with oil passages. The intermediate section is partially cut away to expose the motor and pump bearings and the flexible coupling. The bearings may be oiled and the unit assembled through the opening 65 provided in the intermediate section. The pump section is secured to the intermediate section by flanges or in any other suitable manner and is driven directly from the pump. The electrical connections for 70 the pump may be made through one of the spider arms or through the intermediate section or at any other convenient place. The oil line is joined to the assembly by flanges or in any other suitable manner, the unit 75 being in alignment with the pipe line when assembled.

More particularly referring now to the drawing, an electric motor is housed within a suitable housing 1 which is stream-lined 80 form. The housing 1 is provided with spiders 2 which may be made integral with the housing 1 or secured thereto in any suitable manner. The concentric passageway formed by outer shell 3 and housing 1 provides the 85 space through which the oil coming from pipe line 4 flows. The spider arms 5 are steam-lined in cross section as can readily be seen by reference to Figure 5. Obviously, this will reduce the frictional resistance to the flow of the oil through our device. The outer portion of the spiders 2 terminates in a flattened, ring-like member 6 which is adapted to be interposed between the flange 7 of the shell 3 and the flange 8 of 95 member 9. Suitable gaskets 10 are interposed between the ring 6 and flanges 7 and 8. As many supporting spiders as may be desired may be employed. It will be obvious that the motor will be rigidly supported in 100

a fixed spaced relation in the casing 3, permitting the oil to flow through the concentric passageway thus formed. One of the spider arms 5 may be made hollow, if desired, for the passageway of the electric leads for the motor. The electrical connections may be made in any suitable manner, however, as through the intermediate section 11 of our unit. This intermediate section 11 joins the motor assembly to the pump assembly. The motor shaft 12 passes through a suitable bearing 13 and is connected by a flexible coupling 14 of any suitable type to the pump shaft 15, enabling the pump to be driven directly by the motor. A suitable spring bearing 16 is provided in the intermediate section 11. The intermediate section 11 is provided with lateral openings 17 exposing the bearing 13, the coupling 14, the spring bearing 16 and the pump bearing and stuffing box 18 for inspection, oiling, assembly, and the like. The construction of the intermediate section 11 can be readily understood by reference to Figure 4. The oil flows through section 11 in a divided stream through ducts 19 and 20 provided in the intermediate section 11. The pump section 21 is secured to the intermediate section 11 by means of flanges 22 and 23 or in any other suitable manner. A gasket 24 is interposed between the sections to provide an oil-tight joint. The pump 21 may be of any suitable multistage type, it being understood, of course, that our invention is not in the pump per se but in the pump assembly and its adaptation to the particular manner of utilizing it as a booster pump in a pipe line. The oil flowing through ducts 19 and 20 is led by passageway 33 to the first stage of the multistage centrifugal pump. The pump shown in the drawing is a well known type similar to the Alberger multistage centrifugal pump, having internal hydraulic balance and labyrinth bushing rings, there being no diffusion vanes. The oil passes through the various stages of the pump and leaves through the annular passage formed by the pump casing 25 and the fairing member 26 which is supported by stream-lined spider arms 27. The fairing member 26 also provides a bearing 28 for the pump shaft 15. The pipe line 29 is joined to the pump discharge opening 30 by flanges or in any other suitable manner.

In operation the oil flows from pipe line 4, which is joined by flanges to the motor section 3', through motor section 3' in the concentric passageway formed between the casing 3 and the housing 1. The oil flowing around the housing 1 cools the motor and prevents it from overheating. By this construction we are enabled to use a totally enclosed motor. The oil leaves the concentric passageway in the motor section and flows in a divided stream through ducts 19 and 20.

It will be obvious from the above description that the motor drives the centrifugal pump through flexible coupling 14. The oil from ducts 19 and 20 passes into passageway 33 which leads to the first stage of the centrifugal pump. The impeller blades 31 of the centrifugal pump throw the oil outwardly and it passes through the pump from stage to stage, building up pressure in a manner well known to the art. The oil is thrown outwardly by the impeller 32 of the final stage and passes through the passageway formed by the pump casing and the fairing 26, passing through outlet 30 into pipe line 29 at increased velocity and pressure.

It will be obvious that we have accomplished the objects of our invention. Our construction provides a unit which may be dropped into and fitted between the flanges on a pipe line. Our unit requires no exterior support or foundation and obviates the necessity of buildings or housing facilities. Our assembly may be placed in a ditch or pit or on the surface of the ground directly in line with the pipe line. The cost of a unit of our construction would be approximately ten percent of a Diesel unit of the same capacity. We are enabled to use a totally enclosed electric motor with our construction due to the fact that the oil is utilized to cool the motor. In the event of breakdown or trouble, the unit can be quickly removed and a new unit dropped into place, preventing a shutdown of the pipe line for any extended period of time. Our units are quickly assembled and are rugged, enabling them to stand up under hard usage.

It will be understood that certain features and sub-combinations are of utility and may be employed without reference to other features and sub-combinations. This is contemplated by and is within the scope of our claims. It is further obvious that various changes may be made in details within the scope of our claims without departing from the spirit of our invention. It is, therefore, to be understood that our invention is not to be limited to the specific details shown and described.

If desired, we may provide for additional cooling of the motor by means of air ducts 31 leading from the outside atmosphere to the housing 1. These ducts may be secured in any suitable manner as, for example, by flanges or by screw threads. The housing 1 is provided at the end which opens to the intermediate section 11 which is open to the atmosphere through opening 17 with suitable openings 32' through which the air coming through air ducts 31' and through the housing 1 may escape.

Having thus described our invention, what we claim is:

1. A pipe line distribution system comprising in combination a pipe line adapted to

transport liquids, a booster pump assembly including a casing connected in said line, an electric motor mounted within said casing in spaced relation thereto to define a surrounding passage through which the liquid being pumped is adapted to flow, said motor being provided with a heat conducting housing whereby the liquid being pumped passes over said housing and cools the motor, a pump mounted in alignment with said motor and actuated thereby, an inlet for said pump connected with said passage, a discharge outlet for said pump, and means for connecting said pump assembly in axial alignment and interposed in said pipe line to form a continuation thereof.

2. A liquid transporting pipe line having in combination a pump organization interposed therein, said organization including a casing, a pump operating means mounted within said casing in spaced relation to the walls thereof, a pump connected with said operating means for actuation thereby, means for connecting said casing in said pipe line, the construction being such that the liquid being pumped will flow through said casing in a path which surrounds said operating means.

3. A liquid transporting pipe line as in claim 2, wherein said operating means comprises an electric motor provided with a duct communicating with the atmosphere through which cooling air may be passed.

4. A liquid transporting pipe line having in combination a pumping organization interposed therein, said organization including a casing, an electric motor mounted within said casing in spaced relation with the interior walls thereof to define a passageway therein, a pump connected for actuation by said motor and mounted in axial alignment therewith, means for connecting a pipe line to said casing, and means for connecting a pipe line to said pump discharge, the construction being such that the liquid being pumped will flow through said motor and said pump organization in a substantially axial direction.

In testimony whereof we affix our signatures.

D. J. MORAN.  
EDWIN O. BENNETT.