

19



Europäisches Patentamt
European Patent Office
Office européen des brevets



11 Publication number:

0 369 540 B1

12

EUROPEAN PATENT SPECIFICATION

45 Date of publication of patent specification: **23.03.94** 51 Int. Cl.⁵: **B41F 15/44**

21 Application number: **89202871.3**

22 Date of filing: **10.11.89**

54 **Magnetic bar for a roller squeegee of a rotary screen printing device.**

30 Priority: **14.11.88 NL 8802794**

43 Date of publication of application:
23.05.90 Bulletin 90/21

45 Publication of the grant of the patent:
23.03.94 Bulletin 94/12

84 Designated Contracting States:
AT DE IT NL

56 References cited:
CH-A- 426 711
GB-A- 429 199
GB-A- 450 541
NL-A- 71 981

Kunststoff-Lexikon, Carl Hanser Verlag München Wien 1981, page 399, "Polytetrafluorethylen"

73 Proprietor: **STORK BRABANT B.V.**
Wim de Körverstraat 43a
NL-5831 AN Boxmeer(NL)

72 Inventor: **Beck, Humphry Guido Eduard**
De Stoutheuvel 120
NL-5632 MT Eindhoven(NL)

74 Representative: **Barendregt, Frank, Drs. et al**
EXTERPATENT B.V.
P.O. Box 3241
NL-2280 GE Rijswijk (NL)

EP 0 369 540 B1

Note: Within nine months from the publication of the mention of the grant of the European patent, any person may give notice to the European Patent Office of opposition to the European patent granted. Notice of opposition shall be filed in a written reasoned statement. It shall not be deemed to have been filed until the opposition fee has been paid (Art. 99(1) European patent convention).

Description

The invention relates to a magnetic bar according to the preamble of claim 1.

In such rotary screen printing devices use is generally made of electromagnets, in which a magnetic field is generated by means of coils through-out which a direct current is passed. Through varying the current intensity, the magnetic force of attraction on the coils for the roller squeegee can be varied.

However, these electromagnets have the disadvantage that they produce a large amount of heat, so that additional facilities have to be provided to discharge this heat, in order to avoid buckling of the bar.

In order to find a solution to the problem of heat development with electromagnets, the use of permanent magnets was thought of, as already proposed in Swiss Patent 426,711. The use of permanent magnets does, however, have the disadvantage that the magnetic force of attraction of said magnets on the roller squeegee cannot be varied.

It is therefore an object of the present invention to provide a magnetic bar for a roller squeegee in which permanent magnets are placed, and in which there is the possibility of varying the magnetic force of attraction on the roller squeegee.

This object is achieved according to the invention in a magnetic bar having the features as comprised in the characterising part of claim 1.

When the two parts of the magnetic bar take up a position relative to each other in which the magnetically conducting elements in the plate are in line with the permanent magnets, a maximum magnetic force of attraction will be exerted on the roller squeegee, since so many possible lines of force run via the elements through the roller squeegee. Through shifting the two parts of the magnetic bar from this position relative to each other, the force field transmitted via the elements to the roller squeegee is reduced, so that the roller squeegee is attracted with a smaller force.

The permanent magnets can be taken totally out of contact with the elements in the plate. In this position there will, however, be a small residual field present which acts upon the roller squeegee.

If the magnetic force of attraction has to be switched off completely, the bottom part is according to the invention displaceable in the vertical direction from the top part.

Through this vertical displacement, the magnetic force of attraction on the roller squeegee can be reduced virtually to zero.

According to the invention, the bottom part of the magnetic bar can carry out a rotation through 90° about a longitudinal axis thereof.

The rotation through 90° of the bottom part bearing the permanent magnets results in the magnetic force of attraction being completely switched off. At the beginning of this rotation there is, however, a risk of the roller squeegee being pulled a little to the side due to the residual field. This is undesirable, since the stencil can be damaged as a result. The risk of damage to the stencil is avoided by first removing the bottom part of the magnetic bar approximately 20 mm from the top part, before the bottom part is rotated through 90°.

In respect of the magnetic bar according to the invention reference is made to GB-A-429199. Said publication describes a magnetic bar as such which is used as a work-holder. Said magnetic bar is described as being capable of being demagnetised analogous to the operation of an electric switch; i.e. a use for reducing the magnetic force of attraction to an intermediate value is not envisaged or suggested.

Further GB-A-450 541 describes a magnetic device for holding articles wherein, for releasing said articles, the magnet or magnets can be rotated away from the pole shoes. Also this publication does not envisage or suggest a use in an application in which reduction of the magnetic force of attraction to an intermediate value as desired.

The invention will be explained in greater detail with reference to the appended drawing, in which:

Fig. 1 is a schematic cross-section of a part of the rotary screen printing device through the longitudinal axis of the magnetic bar;

Fig. 2 is a perspective exploded view of the magnetic bar according to the invention; and

Fig. 3 is a view corresponding to that of Fig. 1, showing how the magnetic bar according to the invention works.

As shown in Fig. 1, the magnetic bar 1 comprises a top part 2 and a bottom part 3, the top surface of the top part 2 being provided with a teflon layer 4. A printing blanket 5 of the rotary screen printing device bearing a cloth 6 to be printed glides over this teflon layer, a cylindrical stencil 7 containing a roller squeegee 8 rolling over said cloth 6.

As can be seen more clearly from Fig. 2, the bottom part 3 of the magnetic bar is provided with a number of cylindrical rods 9 which are disposed next to each other with a space between them in the lengthwise direction of the bar, and which each comprise a bottom part 10 fixed to the part 3 of the magnetic bar, a permanent magnet 11, and a top part 12. The permanent magnets 11 are placed in such a way that the polarity of the permanent magnets of the adjacent rods 9 are always alternated. In other words, there is alternately a north pole and a south pole at the top side. The permanent magnets can be of the cobalt/samarium type,

or of the neodymium/iron/boron type, which are the currently strongest available types of permanent magnets. The parts 10 and 12 of each of the cylindrical bars are, like the bottom part 3 of the magnetic bar, preferably made of iron.

The top part 2 of the magnetic bar is plate-shaped and made of a non-magnetically conducting material such as, for example, aluminium. Disc-shaped elements 13, made of a magnetically conducting material such as, for example, iron are disposed herein at regular intervals from each other. The elements 13 are circular, with a diameter which corresponds to that of the cylindrical rods 9, and are placed in such a way relative to each other that each element can always be in line with a corresponding rod 9 of the bottom part 3 of the magnetic bar. The top surfaces of the elements 13 are flush with the top surface of the plate 2, while the elements 13 at the bottom side of the plate 2 project slightly beyond it, the bottom surfaces of the elements 13 thus being in contact with the top surfaces of the corresponding bars 9 of the bottom part 3 of the magnetic bar.

As can be seen clearly from Fig. 3, on a displacement of the bottom part 3 of the magnetic bar in the direction of the double arrow P, the elements 13 in the top part 2 of the magnetic bar will no longer lie fully in line with the rods 9. This means that fewer lines of force will run from the permanent magnets via the elements 13 through the roller squeegee, so that said roller squeegee is attracted less strongly by the magnets. When the rods 9 are between the elements 13, and are thus entirely separated from them, hardly any further line of force will run through the elements 13.

In order to ensure that no magnetic force of attraction at all is exerted on the roller squeegee, the bottom part 3 bearing the permanent magnets can be moved away from the top part in the direction of the double arrow F in Fig. 2, following which said bottom part can be tilted through 90° about a longitudinal axis. If this tilting of the bottom part is carried out without moving this part away from the top part first, the roller squeegee will have a tendency, due to a residual field possibly present, to move sideways at the beginning of the tilting, which can cause damage to the stencil. In general, it is sufficient to move the bottom part approximately 20 mm away from the top part.

This design of the magnetic bar has the advantage that permanent magnets can now be used while retaining the possibility of exerting a variable force of attraction on the roller squeegee. Through the absence of the coils, a considerable weight saving is obtained, on the one hand, while on the other, no heat is developed in the magnetic bar, something which gives rise to problems such as the buckling of the bar.

In the embodiment shown and described, the bottom part of the magnetic bar moves in the lengthwise direction. It is, however, also conceivable for the bottom part to move at right angles to the lengthwise direction of the magnetic bar. In this case the permanent magnets could be placed more closely together.

Claims

1. Magnetic bar (1) for a roller squeegee (8) of a rotary screen printing device, said bar bearing a number of permanent magnets (11) next to each other in the lengthwise direction for the attraction of the roller squeegee, (8), **characterized in that**

- said magnetic bar (1), for varying the magnetic force of attraction on the roller squeegee (8) comprises two parts which can be displaced relative to each other, i.e. a fixed top part (2) and a bottom part (3) which is slidable in the lengthwise direction relative to the top part (2),
- the permanent magnets (11) are disposed in the bottom part (3);
- the top part (2) is a plate of non-magnetically conducting material which is provided locally with elements (13) of magnetically conducting material extending at least over the whole thickness of the plate, while the positioning of the elements (13) relative to each other in the said plate corresponds to the relative positioning of the permanent magnets (11) in the bottom part of the magnetic bar (1), in such a way that the permanent magnets (11) can be taken together into a conducting connection with the appropriate elements in the top part (2); and
- the distance between the elements (13) in the top part of the magnetic bar (1) is greater than the diameter of the permanent magnets (11) in the bottom part (3).

2. Magnetic bar according to Claim 1, **characterized in that** the bottom part (3) is displaceable in the vertical direction away from the top part (2).

3. Magnetic bar according to Claim 1 or 2, **characterized in that** the bottom part (3) can carry out a rotation through 90° about a longitudinal axis thereof.

4. Magnetic bar according to the preceding Claims 1 - 3, **characterized in that** the permanent magnets (11) are accommodated in vertical rods (9) of a magnetically conducting

material.

5. Magnetic bar according to the preceding Claims 1 - 4, **characterized in that** the elements of magnetically conducting material project a little beyond the bottom side of the plate.

Patentansprüche

1. Magnetbalken (1) für ein Rollrakel (8) einer Rotationsiebdruckeinrichtung, wobei besagter Balken eine Anzahl von Permanentmagneten (11) in Längsrichtung nebeneinander für die Anziehung des Rollrakels (8) trägt, dadurch gekennzeichnet, daß
- besagter Magnetbalken (1) zur Veränderung der magnetischen Anziehungskraft auf das Rollrakel (8) zwei Teile aufweist, die relativ zueinander versetzt werden können, d. h. ein fixiertes Oberteil (2) und ein Unterteil (3), welches in Längsrichtung relativ zu dem Oberteil (2) verschieblich ist;
 - die Permanentmagnete (11) im Unterteil (3) angeordnet sind;
 - das Oberteil (2) eine Platte aus einem nicht magnetisch leitenden Material ist, das örtlich mit Elementen (13) aus magnetisch leitendem Material versehen ist, welche sich zumindest über die gesamte Dicke der Platte erstrecken, während die Positionierung der Elemente (13) relativ zueinander in der besagten Platte mit der relativen Position der Permanentmagnete (11) in dem Unterteil des Magnetbalkens (1) derart korrespondiert, daß die Permanentmagnete (11) in eine leitende Verbindung mit den zugehörigen Elementen in dem Oberteil (2) zusammengenommen werden können; und
 - der Abstand zwischen den Elementen (13) in dem Oberteil des Magnetbalkens (1) größer ist als der Durchmesser der Permanentmagnete (11) in dem Unterteil (3).
2. Magnetbalken gemäß Anspruch 1, dadurch gekennzeichnet, daß das Oberteil (3) in vertikaler Richtung von dem Oberteil (2) wegbewegbar ist.
3. Magnetbalken gemäß Anspruch 1 oder 2, dadurch gekennzeichnet, daß das Oberteil (3) eine Verschwenkung um 90° um seine Längsachse durchführen kann.

4. Magnetbalken nach einem der vorhergehenden Ansprüche 1 bis 3, dadurch gekennzeichnet, daß die Permanentmagnete (11) in vertikalen Stangen (9) eines magnetisch leitenden Materials aufgenommen sind.

5. Magnetbalken nach einem der vorhergehenden Ansprüche 1 bis 4, dadurch gekennzeichnet, daß die Elemente aus magnetisch leitendem Material ein wenig über die Unterseite der Platte vorstehen.

Revendications

1. Barreau magnétique (1) pour un racle à rouleau (8) d'un dispositif rotatif d'impression au pochoir par sérigraphie, ledit barreau portant un certain nombre d'aimants permanents (11) disposés les uns à côté des autres dans la direction longitudinale, afin d'attirer la racle à rouleau (8), caractérisé en ce que
- ledit barreau magnétique (1), afin de faire varier la force magnétique d'attraction s'exerçant sur le racle à rouleau (8) comprend deux parties qui peuvent être déplacées l'une par rapport à l'autre, à savoir une partie supérieure fixe (2) et une partie inférieure (3) qui est susceptible de glisser dans la direction longitudinale par rapport à la partie supérieure (2);
 - les aimants permanents (11) sont disposés dans la partie inférieure (3);
 - la partie supérieure (2) est une plaque en matériau non-magnétiquement conducteur muni localement d'éléments (13) en matériau magnétiquement conducteur s'étendant au moins sur toute l'épaisseur de la plaque, tandis que la positions des éléments (13) l'un par rapport à l'autre dans ladite plaque correspond à la position relative des aimants permanents (11) dans la partie inférieure du barreau magnétique (1), de telle sorte que les aimants permanents (11) puissent être disposés ensemble en relation de conduction avec des éléments appropriés de la partie supérieure (2); et
 - la distance entre les éléments (13) de la partie supérieure du barreau magnétique (1) est supérieure au diamètre des aimants permanents (11) de la partie inférieure (3).
2. Barreau magnétique selon la revendication 1, caractérisé en la partie inférieure (3) est susceptible d'être déplacée dans la direction verticale en s'éloignant de la partie supérieure (2).

3. Barreau magnétique selon la revendication 1 ou 2, caractérisé en ce que la partie inférieure (3) est susceptible de subir une rotation de 90° le long de l'un de ses axes longitudinaux. 5
 4. Barreau magnétique selon les revendications précédentes, caractérisé en ce que les aimants permanents (11) présentent une structure de barreaux verticaux (9) en matériau magnétiquement conducteur. 10
 5. Barreau magnétique selon les revendications précédentes, caractérisé en ce que les éléments en matériau magnétiquement conducteur sont légèrement en saillie en-dessous de la face inférieure de la plaque. 15
- 20
- 25
- 30
- 35
- 40
- 45
- 50
- 55
- 5

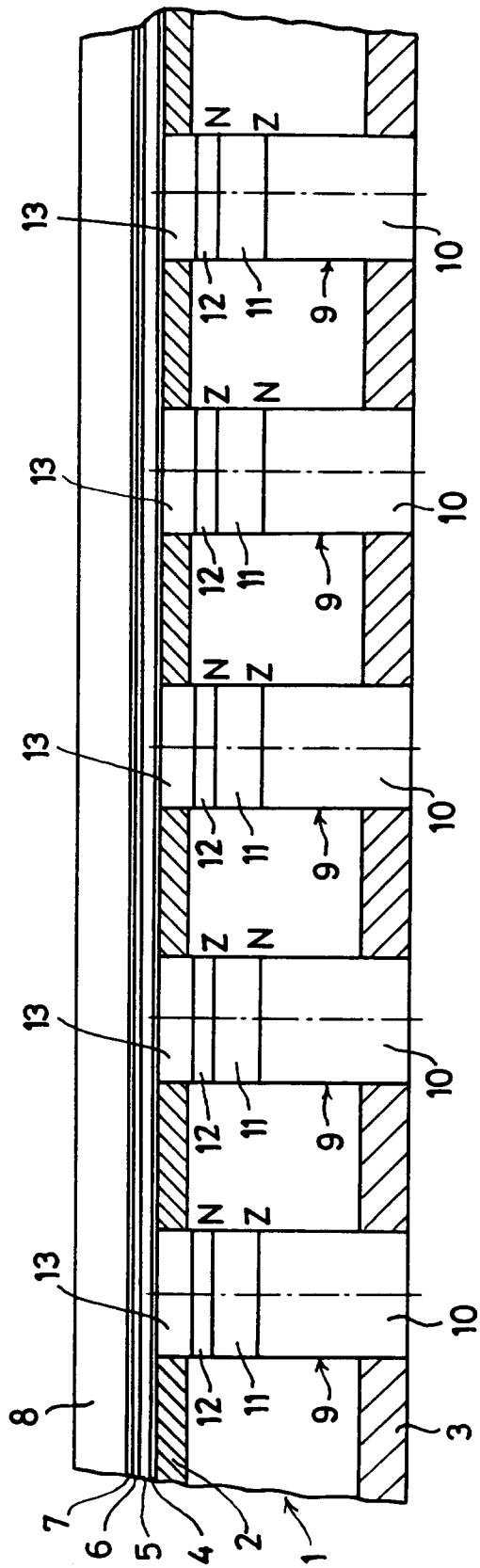

Fig. 2.

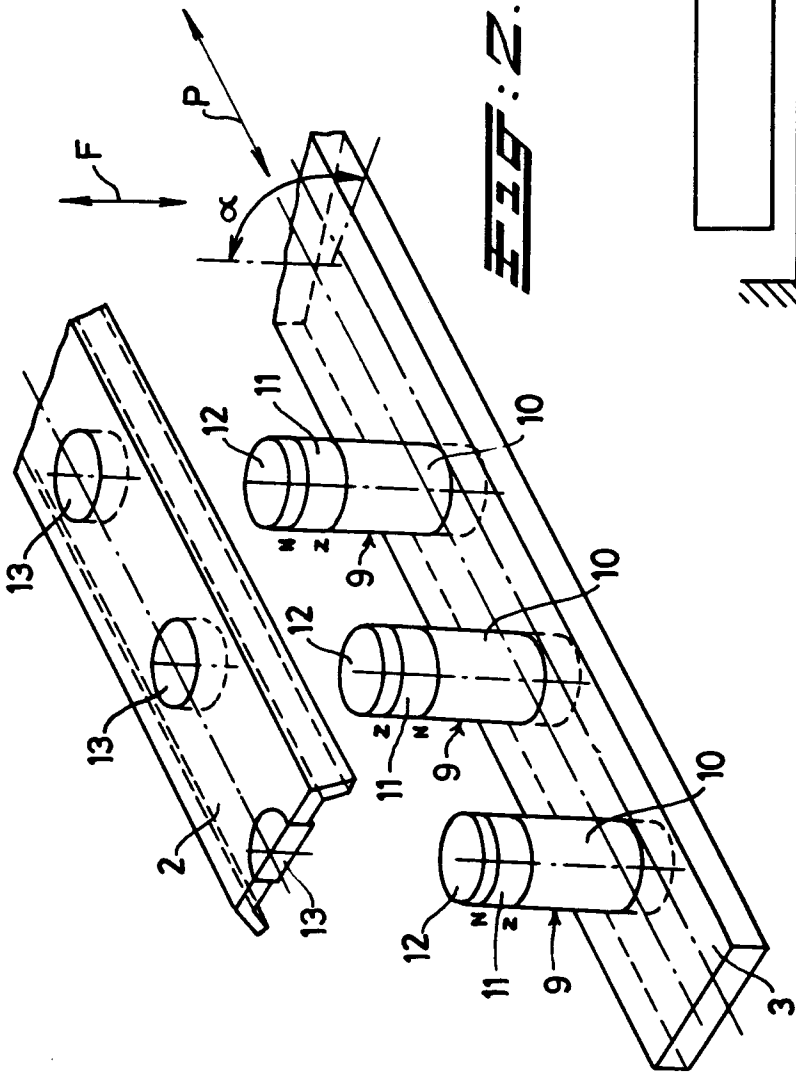

Fig. 2.

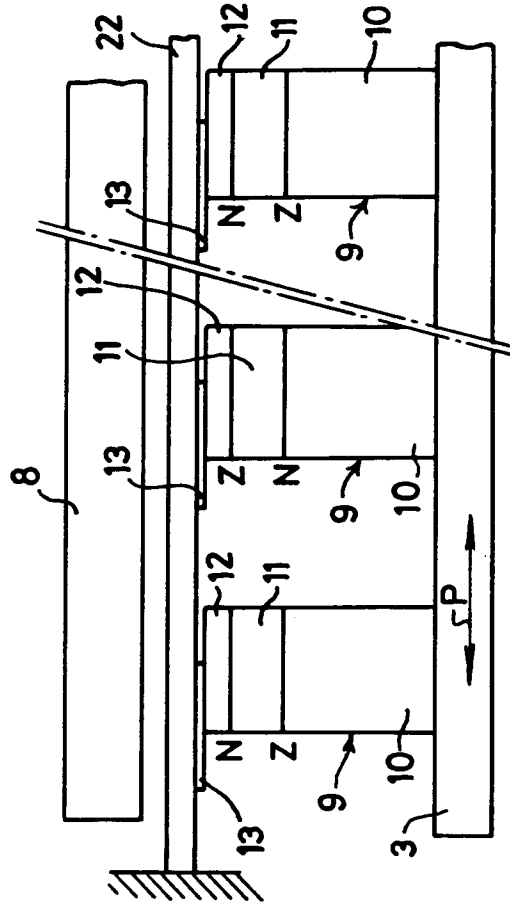

Fig. 5.