



(72) KIM, Young Ran, US
(72) YEE, Michael W., US
(72) MEHTA, Suresh N., US
(72) SAGALA, Josefino C., US
(72) KANTOR, Johanna, US
(71) ABBOTT LABORATORIES, US

(51) Int.Cl.⁶ G01N 33/49, G01N 15/14
(30) 1994/12/15 (08/356,932) US

(54) **PROCEDE D'ANALYSE RAPIDE ET SIMULTANEE DE
GLOBULES ROUGES NUCLEES**

(54) **METHOD FOR RAPID AND SIMULTANEOUS ANALYSIS OF
NUCLEATED RED BLOOD CELLS**

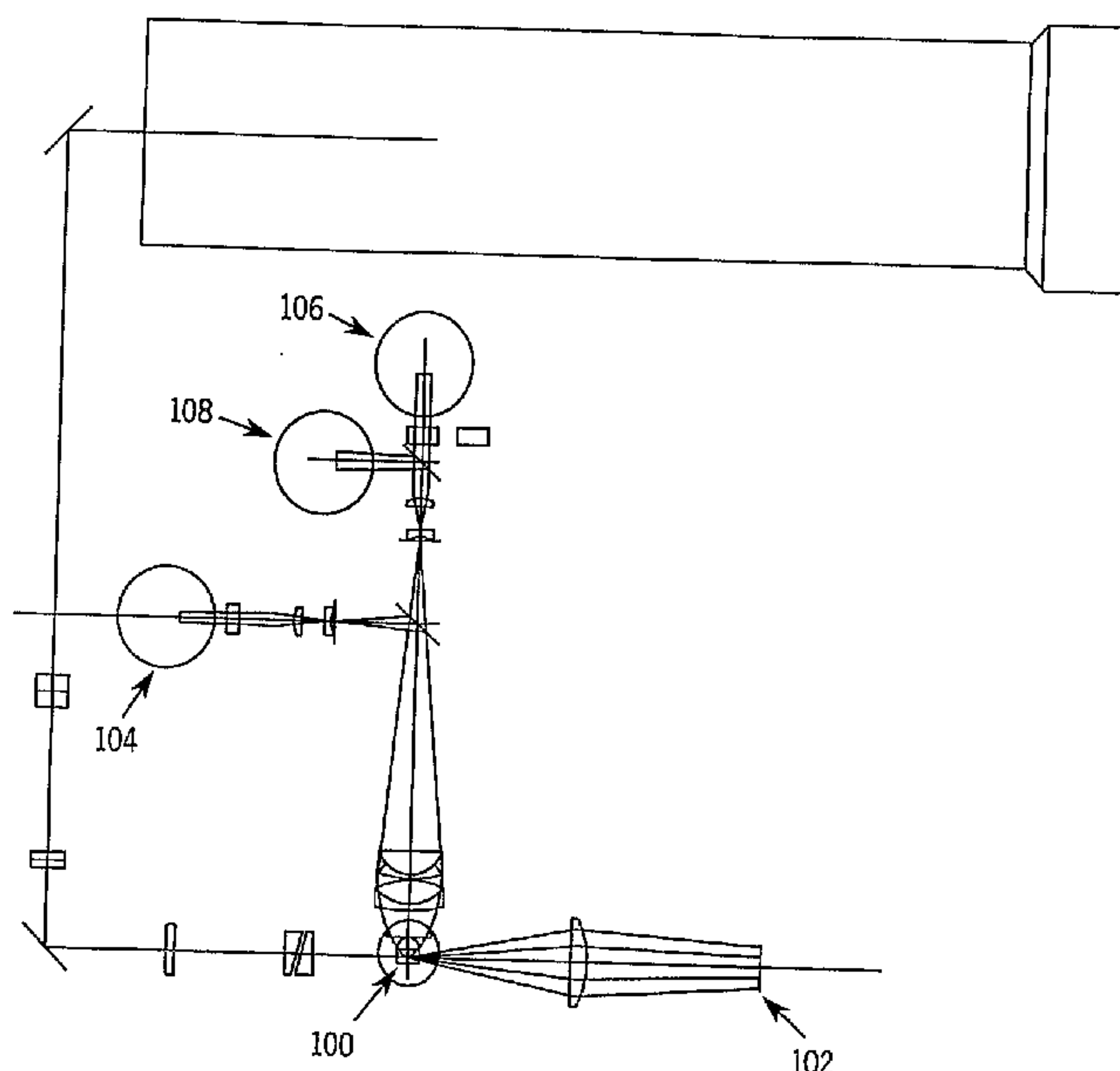

(57) Procédé et appareil d'analyse cytométrique de flux, simultanée et quantitative, de globules rouges nucléés (NRBC) et de globules blancs (WBC) dans un échantillon de sang total. Ce procédé consiste à réaliser la lyse du cytoplasme de globules rouges (RBC) et de NRBC d'une aliquote d'un échantillon de sang total pour éliminer les RBC et soumettre les NRBC à une coloration nucléaire vitale ainsi qu'à inhiber la pénétration du colorant nucléaire dans les WBC, à soumettre l'aliquote colorée à des mesures de la lumière par cytométrie de flux, à obtenir au moins un signal pour des paramètres incluant la lumière diffusée à une

(57) A method and device for the simultaneous and quantitative, flow cytometric analysis of nucleated red blood cells and white blood cells in a whole blood sample. The method includes the lysis of RBC and NRBC cytoplasm from an aliquot of a whole blood sample to eliminate RBC and to expose the NRBC to a vital nuclear stain and the inhibition of the permeation of the nuclear stain into the WBC, subjecting the stained aliquot to flow cytometric light measurements, obtaining at least one signal for parameters including scattered light at a first and a second range of scatter angles and fluorescence (FL), qualifying the obtained signals by



première et à une seconde gamme d'angles de diffusion et la fluorescence (FL), à qualifier les signaux obtenus au moyen de la logique combinatoire dans laquelle un signal qualifié doit être supérieur au second seuil de signal de diffusion, tout en devant être supérieur à l'un ou à l'autre du premier seuil de signal de diffusion et du seuil FL {[premier signal d'angle de diffusion OU signaux FL) et second signal d'angle de diffusion]}, à construire une représentation tridimensionnelle des signaux d'intensité qualifiés de fluorescence et de lumière diffusée à partir des signaux détectés, à distinguer les NRBC et WBC à partir de cette représentation tridimensionnelle construite et à déterminer le nombre de cellules de chaque type.

using the combination logic wherein a qualified signal must be greater than the second scatter signal threshold, while at the same time it must be greater than either the first scatter signal threshold or the FL threshold {[first scatter angle signal OR FL signals) AND second scatter angle signal]}, constructing a three-dimensional plot of qualified intensity signals of fluorescence and scattered light from the detected signals, and differentiating the NRBC and WBC from the constructed three-dimensional plot and determining the number of cells of each.



PCT

WORLD INTELLECTUAL PROPERTY ORGANIZATION
International Bureau

INTERNATIONAL APPLICATION PUBLISHED UNDER THE PATENT COOPERATION TREATY (PCT)

(51) International Patent Classification ⁶ : G01N 15/14	A1	(11) International Publication Number: WO 96/18878 (43) International Publication Date: 20 June 1996 (20.06.96)
<p>(21) International Application Number: PCT/US95/15371</p> <p>(22) International Filing Date: 28 November 1995 (28.11.95)</p> <p>(30) Priority Data: 08/356,932 15 December 1994 (15.12.94) US</p> <p>(71) Applicant: ABBOTT LABORATORIES [US/US]; CHAD 0377/AP6D-2, 100 Abbott Park Road, Abbott Park, IL 60064-3500 (US).</p> <p>(72) Inventors: KIM, Young, Ran; 934G La Mesa Terrace, Sunnyvale, CA 94086 (US). YEE, Michael, W.; 1051 Mango Avenue, Sunnyvale, CA 94087 (US). MEHTA, Suresh, N.; 3543 Gresham Court, Pleasanton, CA 94588 (US). SAGALA, Josefino, C.; 3001 D'amico Drive, San Jose, CA 95148 (US). KANTOR, Johanna; 3120 Middlefield Road, Palo Alto, CA 94306 (US).</p> <p>(74) Agents: SCHMIDT, Richard, D. et al.; Abbott Laboratories, Chad 0377/AP6D-2, 100 Abbott Park Road, Abbott Park, IL 60064-3500 (US).</p>	<p>(81) Designated States: CA, JP, European patent (AT, BE, CH, DE, DK, ES, FR, GB, GR, IE, IT, LU, MC, NL, PT, SE).</p> <p>Published <i>With international search report. Before the expiration of the time limit for amending the claims and to be republished in the event of the receipt of amendments.</i></p>	

(54) Title: METHOD FOR RAPID AND SIMULTANEOUS ANALYSIS OF NUCLEATED RED BLOOD CELLS

(57) Abstract

A method and device for the simultaneous and quantitative, flow cytometric analysis of nucleated red blood cells and white blood cells in a whole blood sample. The method includes the lysis of RBC and NRBC cytoplasm from an aliquot of a whole blood sample to eliminate RBC and to expose the NRBC to a vital nuclear stain and the inhibition of the permeation of the nuclear stain into the WBC, subjecting the stained aliquot to flow cytometric light measurements, obtaining at least one signal for parameters including scattered light at a first and a second range of scatter angles and fluorescence (FL), qualifying the obtained signals by using the combination logic wherein a qualified signal must be greater than the second scatter signal threshold, while at the same time it must be greater than either the first scatter signal threshold or the FL threshold {[first scatter angle signal OR FL signals) AND second scatter angle signal]}, constructing a three-dimensional plot of qualified intensity signals of fluorescence and scattered light from the detected signals, and differentiating the NRBC and WBC from the constructed three-dimensional plot and determining the number of cells of each.

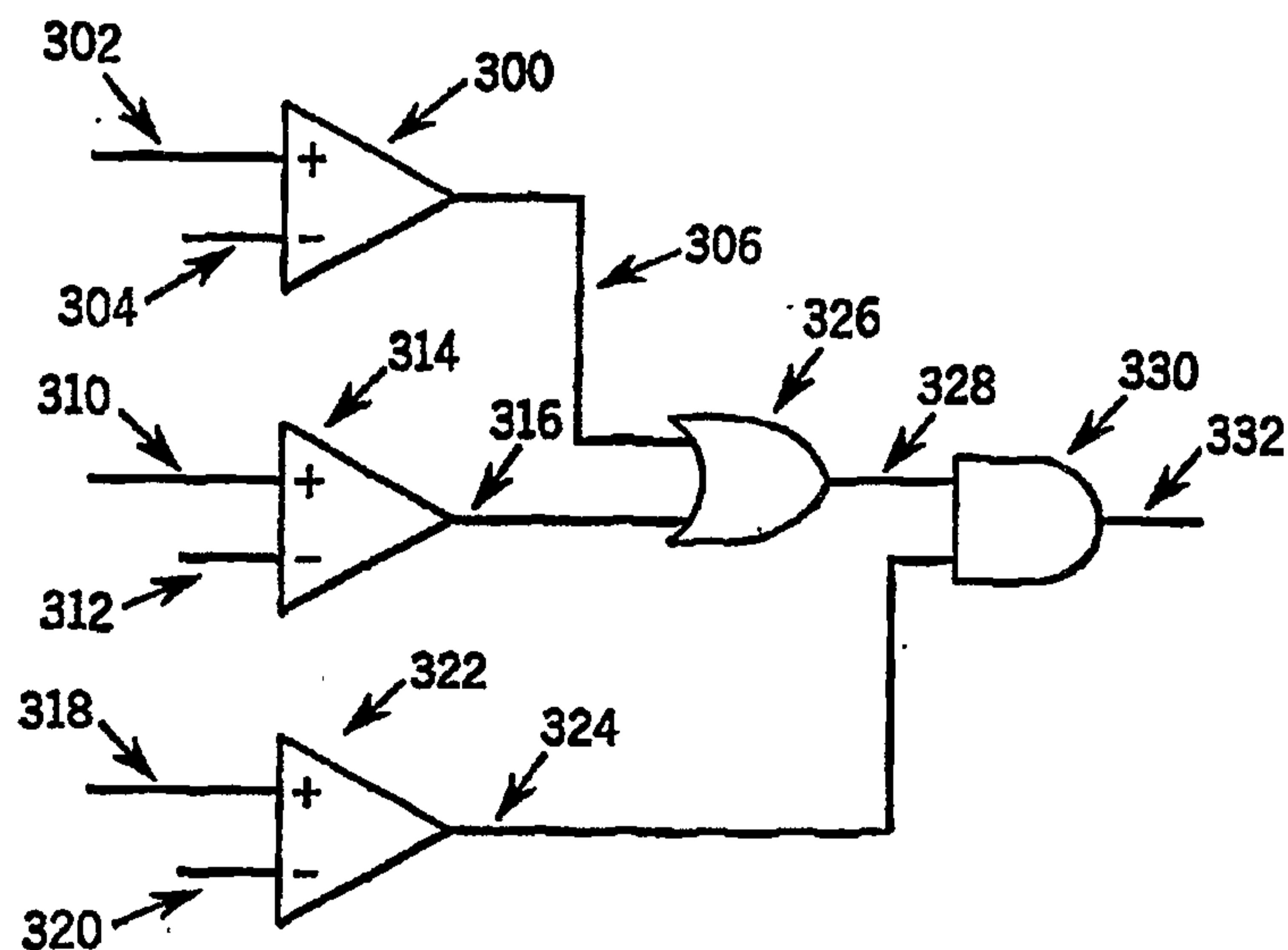

METHOD FOR RAPID AND SIMULTANEOUS ANALYSIS OF
NUCLEATED RED BLOOD CELLS

BACKGROUND OF THE INVENTION

5 This invention relates to a method of differentiating and accurately counting nucleated red cells ("NRBC") in a whole blood sample. In particular this invention relates to a method for the simultaneous differentiation and counting of NRBC and white blood cell ("WBC") sub-populations in a whole blood sample by the use of two light scattering parameters and fluorescence.

10 Events related to the onset of the anemia need to be carefully monitored. The hematology laboratory offers a set of routine or standard procedures relevant to the diagnosis of anemia. The most important of these procedures are the complete blood count (performed on an automated blood cell
15 counter), blood smear morphology, and the reticulocyte production index. NRBC counts are conventionally determined by means of blood smear morphology. A stained blood smear is examined under the microscope and the NRBC are manually counted. In general, an NRBC concentration is reported as
20 number of NRBC per 100 white blood cells ("WBC"). Normally, 200 WBC and the number of NRBC present in the same region on a patient blood smear are counted and the numbers are divided by 2 to express the NRBC concentration as the number of NRBC/100 WBC. The major drawback to this type of manual
25 microscopic method is that it is very labor intensive, time-consuming, subjective and inaccurate due to poor statistics. Therefore, an accurate automated NRBC method has long been sought after by pathologists and laboratory technicians.

30 A major problem in automating a NRBC method for use on a clinical flow cytometer has been that since NRBC are rare

events and RBC populations are so numerous, NRBC populations are not easily detected among the red blood cell ("RBC") population by either the differences in the cell's electrical resistivity (impedance measurements) or its light scattering characteristics (optical measurements). Although many attempts have been made to count NRBC among WBC populations, instead of among RBC population, these efforts have not generally been successful.

NRBC populations are not easily distinguished from WBC populations since NRBC do not form a well defined cluster among the WBC in the usual two dimensional space differentiation methods utilized on flow cytometers. One is usually not able to separate NRBC populations from the lymphocyte populations when the detected signals are viewed on the generally accepted, two-dimensional light scatter (forward vs. side) or light scatter vs. absorption, dot plots. The signals from the majority of the NRBC population is usually mixed in with the signals for RBC stroma and platelets ("PLT"), and the upper-end of NRBC cluster most often will extend into the space occupied by the lymphocyte population.

Automated clinical hematology instruments, such as the Technicon H*1®, Coulter STK® S and Abbott Cell-Dyn® 3000 and 3500 only "flag" samples for the possible presence of NRBC if the sample dot plot shows increased noise signals below the lymphocyte cluster. This type of flagging very often produces false positive results since the elevated noise level could be due to PLT clumps, giant PLT or incompletely lysed RBC. In addition, it is extremely difficult to obtain accurate Total WBC and WBC Differential ("WBC/Diff") results on samples containing NRBC because of the interference. Additionally, blood smears of the flagged samples must be examined and counted under the microscope by a skilled technician to obtain accurate WBC differential and NRBC counts. This is a very labor-intensive and subjective process.

5 Recently, U.S. Patent # 5,298,426, issued on March 29, 1994, to Inami *et al.* This patent teaches a two-step method comprising the staining of WBC and NRBC by specific nuclear stains. In this patented method, a blood sample is first
10 mixed with an acid hypotonic solution containing a fluorescent nuclear dye. Then, a solution comprising an alkaline salt buffer, to adjust pH and Osmolarity, is mixed with the sample/first reagent solution. This final solution is then loaded into a flow cytometer to detect and count NRBC along with other nucleated cells.

15 There are several reasons why the Inami *et al.* approach is not acceptable, especially for an automatable method. First, an acidic-hypotonic solution damages all cell membranes making all WBC leaky and therefore selective staining of NRBC nuclei by a nuclear stain is not possible. There are no known dyes which stain only NRBC nuclei and not WBC nuclei since the nuclear material (DNA) is the same. The nuclear stain claimed by Inami *et al.*, Propidium Iodide, is a
20 commonly used vital nuclear stain that stains dead cell nuclei by permeating damaged cell membrane and intercalates into the DNA helix of any nucleus, not just an NRBC nucleus. Second, the method does not separate or distinguish the fluorescent signals of the NRBC nuclei from that of other nuclear remnants such as Howell-Jolly Bodies, Basophilic
25 Stippling, RNA from lysed reticulocytes and reticulated platelets, and DNA from WBC and Megakaryocytic fragments. Third, the Inami *et al.* method requires that the sample be pretreated, off-line, using several reagents to "prep" the sample before the prepped sample/reagent solution can be
30 loaded into the instrument.

SUMMARY OF THE INVENTION

A method for the simultaneous and quantitative, flow cytometric analysis of nucleated red blood cells and white blood cells in a whole blood sample is provided. The method comprises the destruction of RBC and NRBC cytoplasm from an aliquot of a whole blood sample to expose the NRBC nuclei to a vital nuclear stain and minimizing the permeation of the vital nuclear stain into the WBC, subjecting the stained aliquot to flow cytometric light measurements, obtaining at least one signal for parameters including scattered light at a first and a second range of scatter angles and fluorescence (FL), qualifying the obtained signals by using the combination logic wherein a qualified signal must be greater than the second scatter signal threshold, while at the same time it must be greater than either the first scatter signal threshold or the FL threshold $\{[(\text{first scatter angle signal OR FL signals}) \text{ AND second scatter angle signal}]\}$, constructing a three-dimensional plot of qualified intensity signals of fluorescence and scattered light from the detected signals, and differentiating the NRBC and WBC from the constructed three-dimensional plot and determining the number of cells of each.

In another embodiment of the invention, a device is provided for the simultaneous and quantitative analysis of NRBC and WBC in a whole blood sample. The device comprises a flow cytometer for obtaining at least one signal for parameters including scattered light at a first and a second range of scatter angles and fluorescence (FL or Fl), and a triple triggering circuit that qualifies signals obtained by the flow cytometer for digitation by means of AND/OR logic wherein a qualified signal must be greater than the second scatter signal threshold, while at the same time it must be greater than either the first scatter signal threshold or the

FL threshold {[(first scatter angle signal OR FL signals) AND second scatter angle signal]}.

5 In another embodiment of the invention, a method for the simultaneous and quantitative analysis of nucleated red blood cells and white blood cells in a whole blood sample is provided. The method comprises the elimination of the red blood cells ("RBC") and the cytoplasm of NRBC from an aliquot of a blood sample to expose the NRBC nuclei, staining of the NRBC nuclei with a nuclear stain while minimizing the staining of WBC, subjecting the aliquot to flow cytometric light measurements, obtaining at least one signal for parameters including scattered light extinction at from about 0° to about 1° (ALL), scattered light from about 3°-10° (IAS) and fluorescence (Fl), qualifying the signals obtained by using AND/OR logic wherein the logic comprises [(ALL signals) OR (Fl signals) AND (3°-10° scatter signals)], constructing a three-dimensional plot of qualified intensity signals of fluorescence and scattered light from the detected signals, and differentiating the NRBC and WBC from the constructed three-dimensional plot and determining the number of cells of each.

15
20
25
30
35
In another embodiment of the invention, a flow cytometric device is provided for the quantitative analysis of nucleated red blood cells and white blood cells in a whole blood sample. The device comprises a flow cytometer for obtaining at least one signal for parameters including scattered light at from about 0° to about 1° and from about 3°-10° and fluorescence (Fl) and a triple triggering circuit that qualifies signals obtained by the flow cytometer for digitation by means of AND/OR logic wherein the logic comprises [(0° to about 1° scatter signals) OR (Fl signals) AND (3°-10° scatter signals)] to validate signals for further processing.

BRIEF DESCRIPTION OF THE DRAWINGS

Figure 1 is a schematic diagram of the optics of a clinical flow cytometer that may be employed in implementing the method of the present invention.

Figure 2 is a diagram depicting a "Valid" triple trigger circuit.

Figures 3A, 3B and 3C are drawing ofs the WBC, NRBC, RBC stroma and other background noise distribution of a whole blood sample processed as described in EXAMPLE 1, utilizing standard or normal detection triggers.

Figures 4A, 4B and 4C are drawings of the WBC, NRBC, RBC stroma and other background noise distribution of a whole blood sample processed as described in EXAMPLE 1 utilizing only an 0° to about 1° scatter axial light loss (ALL) trigger.

Figures 5A, 5B, and 5C are drawings of the WBC, NRBC, RBC stroma and other background noise distribution of a whole blood sample processed as described in EXAMPLE 1 utilizing only a 3° - 10° intermediate angle scatter (IAS) trigger.

Figures 6A, 6B and 6C are drawings of the NRBC, RBC stroma and other background noise distribution of a whole blood sample processed as described in EXAMPLE 1 utilizing only a fluorescence (FL3) trigger.

Figures 7A, 7B and 7C are drawings of the NRBC distribution of a whole blood sample processed as described in EXAMPLE 1 utilizing a trigger level for FL3 higher than for the trigger utilized in Figure 6 to eliminate the noise signals.

Figure 8 is a drawing of the WBC, NRBC and other background noise distribution of a whole blood sample processed as described in EXAMPLE 1 utilizing two triggers, ALL and FL3, electronically "OR'ed" together.

Figures 9A, 9b and 9C are drawings of the WBC and NRBC distribution of a whole blood sample processed as described in EXAMPLE 1, utilizing two triggers ALL and FL3

electronically "OR'ed" together with the level of FL3 trigger set at a higher value than in Figure 8.

5 Figures 10A, 10B and 10C are drawings of the WBC and NRBC distribution of a whole blood sample processed as described in EXAMPLE 1, with triggers for ALL, IAS and FL3.

Figures 11A - 11C show the dot plot displays of a normal blood sample processed as described in EXAMPLE 1, utilizing normal or standard detection triggers.

10 Figures 12A and 12B show the cytograms of an abnormal blood with NRBC, processed as described in EXAMPLE 2, utilizing standard or normal detection triggers.

Figure 13a and 13B show the cytograms of an abnormal blood with NRBC, processed as described in EXAMPLE 3, utilizing normal detection triggers.

15 Figures 14A - 14C depict the distributions of a whole blood sample which contained 56 NRBC/100 WBC utilizing the triple trigger (ALL, FL3 and IAS) detection method of the present invention.

20 Figures 15A and 15B depict the distributions of another whole blood sample which contained 140 NRBC/100 WBC, also utilizing the triple trigger (ALL, FL3 and IAS) detection method of the present invention.

25 Figures 16A and 16B show the results of linearity samples that were prepared and processed as described in EXAMPLE 6 by utilizing a method of the present invention.

30 Figure 17 is the correlation plot of an automated hematology analyzer's NRBC counts (ordinate) utilizing a method of the present invention and manual microscopic NRBC counts (abscissa). The data were processed as described in EXAMPLE 7.

DETAILED DESCRIPTION OF THE INVENTION

Broadly, the present invention relates to an automated method for simultaneous analysis of WBC/Diff and NRBC in a whole blood sample using a unique triple triggering method. This method enables accurate NRBC counts and WBC/Diff data, simultaneously from a whole blood sample containing NRBC.

An important aspect of the present invention is that the signals from debris (both fluorescent and non-fluorescent) are blocked by the triple triggering method and the signals which fall below the ALL trigger but above the FL3 trigger can be identified and counted as NRBC. Therefore, accurate NRBC counts, which are essentially free of contamination from fluorescent nuclear debris, are obtained. Fragile blast cells and dead cells may also be detected utilizing the methods of this invention.

In the triple trigger method, it is possible to simultaneously count WBC/Diff and NRBC accurately by mixing the blood sample with a blood diluent which rapidly lyses RBC and preserves WBC, and to which has been added a suitable nuclear stain which will stain naked nuclei of the NRBC. Such a diluent is disclosed in U.S. Application Serial Number 08/297,662, entitled "MULTIPURPOSE REAGENT SYSTEM FOR RAPID LYSIS OF WHOLE BLOOD SAMPLES", filed on August 29, 1994, and herein incorporated by reference thereto. The diluent/sample mixture is then passed, essentially a cell at a time through an illuminated optical flow cell. This causes the cells to scatter the illuminating light and any stained nuclei present to fluoresce. The scattered and fluorescent light signals are detected by known means and, by using the triple triggering method in conjunction with the processing of the detected signals it is possible to identify and quantify WBC, WBC/Diff and NRBC. A hematology analyzer which has been found to be particularly compatible with the triple trigger method of this invention is disclosed and described in U.S. Application

Serial No. 08/283,379, entitled "METHOD AND APPARATUS FOR PERFORMING AUTOMATED ANALYSIS", filed on August 1, 1994, and is herein incorporated by reference thereto.

5 The triple trigger method is unique in that the simultaneous analysis of WBC/Diff/NRBC can be carried out automatically, accurately, and rapidly without interference from other cellular debris such as RNA from lysed reticulocytes, Howell Jolly Bodies, reticulated platelets, giant platelets, DNA from WBC and Megakaryocytic fragments, 10 parasites, and RBC fragments. Further advantage of the present invention is that it has a very high clinical value in that the method can be incorporated into a clinical hematology analyzer which routinely calibrate for WBC, RBC, and Platelet counts. Such a system is capable of producing an accurate WBC/Diff /NRBC data (percent as well as absolute 15 counts) in clinical blood samples. This has not previously been possible.

The triple trigger method also permits accurate WBC/Diff analysis in a blood sample that contains NRBC by subtracting 20 signals identified as NRBC from the total WBC signals before WBC/Diff analysis is performed. Only one dye is needed for NRBC staining and the WBC/Diff analysis can be performed by the difference of light scattering characteristics of the WBC subclasses.

25 The present invention achieves all of the objectives described above by a unique triple triggering method in the three dimensional space of Axial Light Loss (ALL), Intermediate Angle Scatter (IAS) and Red Fluorescence (FL3).

To accomplish this, one or more detectors are preferably 30 placed in the forward light path for measuring forward intermediate angle scattering (IAS) and either small angle forward scattering (SAS) or axial light loss (ALL, also known as forward extinction). ALL is generally the decrease in light energy due to a cell passing in front of a laser beam and being detected by a photodiode. The light loss is 35

generally due to scattering and defined as the decrease in light energy reaching a detector in the path of a laser beam due to the passage of a cell through that beam (generally ALL is detected at an angle of from about 0° to about 1° .) Small angle forward scatter (SAS), in contrast, is light energy that reaches a detector outside (but within a narrow angle of about 1° to 3°) the incident laser beam due to scattering from a cell passing through the beam. A beam stop is generally provided to keep the laser beam from getting into the detector. ALL measuring systems collect light within the incident cone of laser illumination, while small angle scatter systems collect light outside this cone. In ALL measuring systems, the signal of interest is a negative signal subtracted from the steady state laser signal, whereas in small angle forward scatter measurement the signal is a small positive signal imposed on a very low background light level. Intermediate angle forward scattering (IAS) is similar to small angle forward scattering, except the light is scattered at a larger angle from the incident laser beam. More specifically, IAS relates to light scattered in a ring between about 3° and 10° away from the incident or center line of a laser beam. In a preferred embodiment, ALL is collected in the angles less than about 0.3° horizontally and less than about 1.2° vertically from the laser axis, and IAS is collected at angles between about 3° and 10° from the laser axis.

Another technical advantage of the disclosed system is that it requires much lower concentration of the dye to effectively and rapidly stain NRBC for accurate detection and counting because of complete lysis of the cytoplasm of NRBC making their nuclei more accessible to the stain. This condition permits high signal to noise (S/N) ratio, greater than 100, in NRBC detection. The concentration of a vital dye required this system to rapidly perform the simultaneous

analysis of WBC/Diff/NRBC is only 1 to 2 $\mu\text{g/ml}$ which is at least 50 fold less than that in the previous art.

5 Vital stains (nuclear stains which stain only dead or damaged cells) that can be used in the present invention can be any vital stain with relatively high extinction
10 coefficient and low fluorescence intensity when they are not bound to nucleic acid. The spectral characteristics, i.e. Extinction (EX) max. (nm) / Emission (EM) max. (nm), of the vital dyes must be compatible with the laser light source used in the system.

The following characteristics are desired for the vital stains for the disclosed system:

High extinction coefficient

High quantum yield

15 High binding affinity to nucleic acid

Low fluorescence when it is not bound to nucleic acid

Light source compatibility of Spectral Characteristics.

(e.g. EX max. ~488 nm and EM max. ~ 630 nm with an Argon laser light source.)

20 There are a number of nuclear dyes qualified for use in the disclosed system with appropriate light source. Some of the commercially available dyes that can be used in the disclosed system are YOYO-1, YOYO-3, TOTO-1, TOTO-3, BO-PRO-1, YO-PRO-1, TO-PRO-1, and many more. It is known to those
25 who are familiar in the art that the dyes with different EX max. can be excited with appropriate light source such as He-Ne, Xenon or Mercury lamps.

Qualified dyes which can be used with an Argon laser which are also commercially available are Propidium iodide
30 (PI), ethidium bromide (EBr), ethidium homodimer-1 (EthD-1), ethidium homodimer-2 (EthD-2) or diethylene triamine (DTA). In one application of the present invention, the vital stain used is PI. A multipurpose reagent system (US Application
Serial No. 08/297,662) having a pH of about 6.5, osmolarity
35 of about 260, and comprises an acetate buffer (about 15 mM),

ammonium chloride (about 5.0 g/L), potassium bicarbonate (about 2 g/L), saponin (about 100 mgs/L) and formaldehyde (about 0.07 %) is used to carry-out a one-step simultaneous analysis of WBC/Diff/NRBC at about 42°C within one minute.

5 US Patent Application Serial No. 08/283,379, entitled "METHOD AND APPARATUS FOR PERFORMING AUTOMATED ANALYSIS", filed on August 1, 1994, and incorporated herein by reference, discloses an automated Hematology analyzer which utilizes light scatter signals ALL and IAS, among others, as well as various fluorescent signals to differentiate cells and subclasses of cells from a whole blood sample. The following description is defined by this hematology analyzer. Such a description is merely for convenience and by no means is the present invention limited to only one instrument.

15 A portion of a whole blood sample, about 25 microliters, is deposited by means of a sample aspiration probe into the WBC cup which contains about 850 microliters of an isotonic lysing reagent. A lysing reagent is used to lyse the erythrocyte fraction of the blood sample and to lyse the cytoplasm of NRBC to expose the nuclei of any NRBC present. In addition to lysing the erythrocyte fraction of the blood, the reagent must be gentle enough to protect or not damage the WBC fraction. One such lysing reagent system is disclosed in US. Patent Application Serial No. 08/297,662, entitled
25 "MULTIPURPOSE REAGENT SYSTEM FOR RAPID LYSIS OF WHOLE BLOOD SAMPLES", filed on August 29, 1994, and is herein incorporated by reference. This reagent system is characterized in that it embodies a one reagent/one step process that achieves multipurpose goals. This reagent is gentle enough to preserve the morphology of all fragile white cells, and at the same time efficiently lyse all of the red cells. Both of these goals are accomplished even in hemaglobinopathic samples, which may require that the lysing time be extended. No matter what the formulation of the lyse
30 utilized with the triple trigger method, the reagent will

5 additionally contain, or be combined with, a small concentration of a vital nuclear stain which effectively labels any NRBC which might be present in the peripheral blood. Preferably, for use with the above referenced analyzer, the lysis chemistry will be configured such that the refractive index matches that of a sheath solution to substantially less than 0.1%.

10 The mixture of lyse reagent and sample will normally remain in the above referenced WBC cup only for 11 seconds. There it is lysed and mixed at $42^{\circ}\text{C} \pm 3^{\circ}\text{C}$. At this point, the contents of the WBC cup are piped directly to an optical flowcell 100 for detection, see Figure 1.

15 The measurement process begins as the cells stream passes through the flowcell 100, having been diluted with the addition of lyse so that the cells pass through the laser illuminated volume single file, in a laminar flowing sample stream surrounded by diluent/sheath solution. The illuminated volume is bounded in the two dimensions normal to the flow axis by the hydrodynamically focused cell stream, and in the dimension parallel to the flow axis by the vertical beam waist of the laser beam which is about 17 microns. When doing this test, the sample flow rate is about 2.5 microliters per second, and the corresponding illuminated sensing volume of the WBC and NRBC cells approximates an elliptical cylinder with dimension of about $80 \times 5 \times 17$ microns. The 17 micron dimension is measured along the axis of the cylinder.

20 At this point and as shown in Figure 1, the presence of a cell is detected by a compound photodiode 102 detecting axial light loss (ALL) and intermediate angle scatter (IAS), photomultiplier tube 104 which detects red fluorescence, and a unique triple trigger circuit, shown in Figure 2, in the three dimensional feature space of ALL, IAS, and FL3 (red fluorescence). The triple trigger circuit qualifies signals for digitization using AND/OR logic. A qualified signal must

25
30
35

be greater than the IAS trigger, while at the same time it must be greater than either the ALL trigger or the FL3 trigger. The combination of this unique triggering circuit, and the lysing properties which include a balanced fixative, allow the exposed NRBC nuclei to be rapidly stained, and clearly and non ambiguously counted and excluded from the WBC differential cell count without the usual interference from background, both fluorescent and non-fluorescent, such as DNA fragments, RBC stroma, and platelets.

One or more detectors are preferably placed in the forward light path for measuring forward intermediate angle scattering (IAS) and either small angle forward scattering (SAS) or axial light loss (ALL, also known as forward extinction). ALL is generally the decrease in light energy due to a cell passing in front of a laser beam and being detected by a photodiode. The light loss is generally due to scattering and defined as the decrease in light energy reaching a detector in the path of a laser beam due to the passage of a cell through that beam (generally ALL is detected at an angle of from about 0° to about 1° .) Small angle forward scatter (SAS), in contrast, is light energy that reaches a detector outside the incident laser beam (but within a narrow angle of from about 1° to 3°) due to scattering from a cell passing through the beam. A beam stop is generally provided to keep the laser beam from getting into the detector. ALL measuring systems collect light within the incident cone of laser illumination, while small angle scatter systems collect light outside this cone. In ALL measuring systems, the signal of interest is a negative signal subtracted from the steady state laser signal, whereas in small angle forward scatter measurement the signal is a small positive signal imposed on a very low background light level. Intermediate angle forward scattering (IAS) is similar to small angle forward scattering, except the light is scattered at a larger angle from the incident laser beam.

More specifically, IAS relates to light scattered in a ring between about 3° and 10° away from the incident or center line of a laser beam. In a preferred embodiment, ALL is collected in the angles less than about 0.3° horizontally and less than about 1.2° vertically from the laser axis, and IAS is collected at angles between about 3° and 10° from the laser axis.

When cells, thus triggered, pass through the aforementioned illuminated volume, pulses are generated at detectors 102, 104, 106 and 108. The amplitudes of these pulses are then filtered, amplified, digitized, and stored in list mode in the corresponding five dimensional feature space of ALL, IAS, FL3, PSS (polarized side scatter), and DSS (depolarized side scatter). The normal counting time through flowcell 100 is 10 seconds. At the flow rate and dilution ratio described above, with a normal patient WBC count of 7000 cells per microliter of blood volume, the resulting event count rate would be 5000. In low count samples, this counting time can be automatically extended in order to improve the statistics of the measurement. At the conclusion of the measurement time, the sample stream is piped to waste, and probe is cleaned and dried and prepared to process a subsequent sample.

Algorithms are then applied to the list mode data of the aforementioned feature space of ALL, IAS, FL3, PSS, and DSS, and the following cell types are enumerated and/or flagged within less than 30 seconds of processing time:

<u>CELL TYPES ENUMERATED</u>	<u>PERCENTAGES</u>	<u>FLAGGED OR</u>
<u>ENUMERATED</u>		
White Cell concentration (WBC)		
Neutrophil concentration	%N of WBC	
Lymphocyte concentration	%LYMPH of WBC	
Monocyte concentration	%MONO of WBC	

	<u>CELL TYPES ENUMERATED</u>	<u>PERCENTAGES</u>	<u>FLAGGED OR</u>
	<u>ENUMERATED</u> (cont'd)		
	Eosinophil concentration	% EOS of WBC	
5	Basophil concentration	%BASO of WBC	
	NRBC	%NRBC of WBC	
	Band concentration		(BAND)
	Blast concentration		(BLST)
	Immature gran. conc.		(IG)
10	Variant-lymph conc.		(VARL)

ALL and IAS signals are detected and collected for the WBC/Diff analysis and FL3 signals from stained NRBC nuclei are collected for NRBC analysis, as will be described below.

15 The triple trigger circuit, shown in Figure 2, qualifies these signals for digitization using AND/OR logic. To be qualified a signal must be greater than the IAS trigger, while at the same time it must be greater than either the ALL trigger or the FL3 trigger.

20 The various components and generated or utilized signals identified in Figure 2 correspond to the following labels:

	300 - ALL Voltage Comparator
25	302 - ALL Signal
	304 - ALL Threshold Voltage (Vth1)
	306 - ALL Voltage Comparator Output
	310 - FL3 Signal
	312 - FL3 Threshold Voltage (Vth2)
30	314 - FL3 Voltage Comparator
	316 - FL3 Voltage Comparator Output
	318 - IAS Signal
	320 - IAS Threshold Voltage (Vth3)
	322 - IAS Voltage Comparator
35	324 - IAS Voltage Comparator Output

17

326 - OR Gate
328 - OR Gate Output
330 - AND Gate
332 - Valid Trigger Output

5

Real time signals from their respective channels are present at the inputs of the voltage comparators. Voltage comparators 300, 314 and 322 function by comparing the "+ inputs" (302, 310 and 318) to the "- inputs" (304, 312 and 320) to resultant outputs (306, 316, 324). If the "+ input" is of a higher voltage than the "- input" the output will be high. If the "+ input" is of a lower voltage than the "- input" the output will be low.

15

The threshold voltages are independent voltages which are determined by system parameters.

The outputs of comparators 300 and 314 are inputs to OR gate 326 to give resultant OR gate output 328. The OR gate functions by comparing its inputs. The output will be high if either, or both, inputs are high.

20

The output of the OR gate 328 and the output of comparators 322 and 324 are inputs to AND gate 330. The AND gate functions by comparing its inputs to derive its output 332 which is also also the valid trigger output. The output will be high only if both inputs are high.

25

The valid trigger output 332) will only be high if the IAS signal 318 is greater than its threshold voltage 320, and either or both, the ALL signal 302 is greater than its threshold voltage 304 or the FL3 signal 310 is greater than its threshold voltage 312.

30

Using the above triggering circuit, the NRBC's form a unique cluster in the aforementioned three dimensional space, see Figures 14 and 15, which can be easily counted during the Optical WBC Differential analysis, and exclude non ambiguously from the WBC count. Thus, a count of NRBC per 100 WBC, and an absolute NRBC per μ l of patient blood is

35

reported. Consequently, NRBC are subtracted from total WBC counts permitting accurate total WBC and Differential analysis in the presence of NRBC in a blood sample. Background noise, both fluorescent and non-fluorescent, from DNA fragments, RBC stroma, platelets, Howell-Jolly Bodies, Basophilic Stippling, RNA from lysed reticulocytes and DNA from WBC and Megakaryocytic fragments are substantially eliminated. Stained NRBC nuclei are separated from the various background noise signals via the disclosed triple-triggering process (on ALL, IAS and FL3) and only the FL3+ signals from NRBC nuclei above the FL3 trigger on the ALL vs. FL3 dot plot are counted as NRBC.

In Figures 3 through 10 the cell population areas identified by the below listed numbers, correspond to the following cell types:

202 = Lymphocytes	208 = Origin Noise
204 = Monocytes	210 = NRBC
206 = Granulocytes	212 = Stroma

EXAMPLE 1

An EDTA-anti-coagulated fresh normal blood was run on an experimental unit of the automated clinical hematology analyzer described above and disclosed in US Patent Application Serial No. 08/283,379, entitled "METHOD AND APPARATUS FOR PERFORMING AUTOMATED ANALYSIS", filed on August 1, 1994, and incorporated herein by reference. While the present invention was incorporated into the aforementioned analyzer it was not always utilized in all of the following examples. Twenty five (25) micro-liters of the blood sample were mixed on-line with 675 micro-liters of the isotonic multipurpose reagent (pH 6.5, 260 mOsm/L) disclosed in U.S. Application Serial Number 08/297,662, entitled "MULTIPURPOSE

REAGENT SYSTEM FOR RAPID LYSIS OF WHOLE BLOOD SAMPLES", filed on August 29, 1994, and herein incorporated by reference.

For the purposes of these experiments the multipurpose reagent system is comprised of about 95 mM ammonium chloride (5g/l), about 0.075% by volume of formaldehyde, from about 10 mM to about 20 mM acetate buffer, about 10 mM potassium bicarbonate, and about 0.01% by weight volume (i.e., grams per 100 ml) of saponin. The pH of the reagent system is adjusted to a range of from about 6.2 to about 7.0 and the osmolality of the reagent system is from about 215 to about 270 mOsm/L.

The reagent is pre-warmed at $42^{\circ}\text{C} \pm 3^{\circ}$ in the instrument's heated mixing chamber, where the sample and reagent are mixed and incubated for 11 seconds. This mixture was then transported to the flow cell (which takes 8 and 1/2 seconds) for the WBC/Diff/NRBC analysis. The optical configuration of the system is presented in Figure 1. The analysis was performed without implementing the triple triggering circuit; using only ALL and FL3 dual triggers as is common in the art. See all Figures from Figure 3A through 10C.

The upper dot plot display, Figure 11A maps the light scatter signals (ALL vs. IAS) obtained from the sample and show 3 distinct populations of WBC. The Basophil cluster is not apparent here because normal bloods do not contain many Basophils. The Eosinophil cluster is not shown here since Eosinophils are separated via a DSS vs. PSS dot plot (not shown) and the middle cytogram, Figure 11B is a dot plot display of ALL and FL3 signals as labeled. Note that normal bloods do not contain any NRBCs. The lower bottom FL3+ cluster, Figures 11B and 11C, is apparently cell debris containing RNA or DNA, as described earlier.

EXAMPLE 2

5 Figures 12A and 12B top and bottom cytograms respectively,
are dot plot displays of an abnormal blood with NRBC (47
NRBC/100 WBC) analyzed as described in EXAMPLE 1 utilizing a
standard detection method. The cluster right below the
lymphocyte population in the top cytogram belongs to NRBC and
the small cluster at the bottom, left corner belongs to the
origin noise which include RBC stroma (reticula, Howell Jolly
10 Bodies and etc.), platelets and WBC debris. Figure 12B shows
that the origin noise cluster of this sample stained with the
nuclear dye brightly, following the stained NRBC cluster very
closely in FL3 channel, thereby making it impossible to set
the FL3 trigger to count NRBC accurately.

15

EXAMPLE 3

The cytograms for Figures 13A and 13B are dot plot
displays of an abnormal blood with NRBC (51 NRBC/100 WBC)
20 analyzed as described in EXAMPLE 1 utilizing a standard
detection method. The cluster right below the lymphocyte
population in the top display, Figure 13A belongs to NRBC. An
increased FL3+ origin noise of this sample can be seen. The
noise cluster is located very close to the NRBC cluster in
25 the FL3 channel. Thus, the FL3 noise is interfering with the
position of the FL3 trigger. When the FL3 trigger was set
high enough to eliminate all the origin noise, a part of the
NRBC population was also lost below the FL3 trigger as shown
in Figure 13B.

30

EXAMPLE 4

The disclosed triple trigger circuit (ALL/IAS/FL3) of the
present invention was incorporated into the same instrument

used in EXAMPLES 1 through 3 and utilized during this procedure.

5 A EDTA, anti-coagulated clinical sample which contained 56 NRBC/100 WBC was processed as described in EXAMPLE 1. The results are presented in Figures 14A through 14C. Note the disappearance of the FL3+ noise cluster. The noise signals are blocked by the added IAS trigger. The fluorescent origin noise from this abnormal blood is no longer visible above the FL3 trigger, although the trigger is set low enough to
10 recover the total NRBC population. (Note the circular shape of the NRBC cluster.)

EXAMPLE 5

15 Figures 15A and 15B show the dot plot displays of the NRBC distribution of another clinical whole blood sample which contained 140 NRBC/100 WBC, also post triple trigger (ALL, FL3 and IAS) implementation. The origin noise is not visible and the total NRBC population is recovered above the FL3
20 trigger. Note the heavy density of the NRBC cluster due to the very high concentration of NRBC in this sample.

EXAMPLE 6

25 Linearity samples were prepared by adding various concentrations of unfixed chicken erythrocytes to a EDTA, anti-coagulated normal human blood. The samples were processed as described in EXAMPLE 1 utilizing the triple trigger detection method of the present invention. The
30 cytoplasm of chicken erythrocytes lyse in the method of present invention leaving only naked nuclei (CEN). The CEN stained very rapidly with the vital nuclear stain (PI) in the diluent and become fluorescent (FL3). The FL3+ CEN are counted as NRBC and reported as number of NRBC/100 WBC and as
35 absolute counts per μL of the whole blood sample in the

method of the present invention. The results are presented in Figures 16A and 16B. The linearity plots of NRBC/100 WBC and NRBC in absolute numbers in the figure demonstrate that the method of the current invention generate a linear NRBC counts.

5

EXAMPLE 7

Figure 17 shows the correlation plot of NRBC counts (ordinate) of 85 clinical samples obtained by the method of the current invention. The results were correlated to that of reference manual microscopic counts (abscissa). For manual NRBC counts, 200 cell WBC differential was performed on each patients' blood smears stained with Wright-Giemsa and NRBC counts present in the same region were divided by 2 to report NRBC/100 WBC. Correlation coefficient (R) is 0.973 ($R^2 = 0.946$), the slope is 0.86 and Y-intercept is 1.32.

10

15

WHAT IS CLAIMED IS:

1. A method of differentiating nucleated red blood cells (NRBC) from other cells by flow cytometry which comprises:
 - (a) mixing an aliquot of a blood sample with a reagent system comprising a RBC lysing component, a leukocyte fixing component and a vital nuclear stain component to stain the nuclei of the NRBC;
 - (b) subjecting the mixed aliquot, substantially a cell at a time, through an area of optical stimulation;
 - (c) obtaining at least one signal for parameters including fluorescence (FL) and scattered light at a first and second range of scatter angles;
 - (d) qualifying the signals obtained by subjecting the signals to a logic wherein a qualified signal must be greater than the second scatter signal threshold, while at the same time it must be greater than either the first scatter signal threshold or the FL threshold;
 - (e) constructing a three-dimensional plot of intensity signals of FL and scattered light from the detected signals; and
 - (f) differentiating the NRBC and white blood cells (WBC) from the constructed three-dimensional plot and the qualified signals and determining the number of cells of each.
2. The method of claim 1 wherein the first scatter angle is from about 0° to about 1° .
3. The method of claim 1 wherein the first scatter parameter is axial light loss (ALL).
4. The method of claim 3 wherein the ALL is obtained at an angle from about 0° to about 1° .

5. The method of claim 1 wherein the second scatter angle is from about 3° - 10° .

6. The method of claim 1 wherein the nuclear stain is selected from the group of vital stains consisting of propidium iodide (PI), ethidium bromide (EBr), ethidium homodimer-1 (EthD-1), ethidium homodimer-2 (EthD-2) and diethylene triamine (DTA).

7. A method of differentiating nucleated red blood cells (NRBC) from other cells by flow cytometry which comprises:

(a) mixing an aliquot of a blood sample with a reagent system comprising a RBC lysing component, a leukocyte fixing component and a nuclear stain component to stain the nuclei of the NRBC;

(b) subjecting the mixed aliquot, substantially a cell at a time, through an area of optical stimulation;

(c) obtaining at least one signal for parameters including fluorescence (FL) and scattered light at a range of scatter angles comprising from about 0° to about 1° and about 3° - 10° wherein at least one scattered light parameter includes axial light loss;

(d) qualifying the signals obtained by subjecting the signals to a logic wherein a qualified signal must be greater than the 3° - 10° scatter signal threshold, while at the same time it must be greater than either the 0° to about 1° signal threshold or the FL threshold;

(e) constructing a three-dimensional plot of intensity signals of FL and scattered light from the detected signals; and

(f) differentiating the NRBC and white blood cells (WBC) from the constructed three-dimensional plot and the qualified signals and determining the number of cells of each.

8. The method of claim 7 wherein the nuclear stain is selected from the group consisting of propidium iodide (PI), ethidium bromide (EBr), ethidium homodimer-1 (EthD-1), ethidium homodimer-2 (EthD-2) and diethylene triamine (DTA).

9. A flow cytometer for the differentiation of cells from a blood sample further comprising a triple trigger circuit that implements the logical expression [(0° to about 1° scatter signals) OR (Fl signals) AND (3°-10° scatter signals)] to qualify signals obtained from light scatter signals and fluorescent signals.

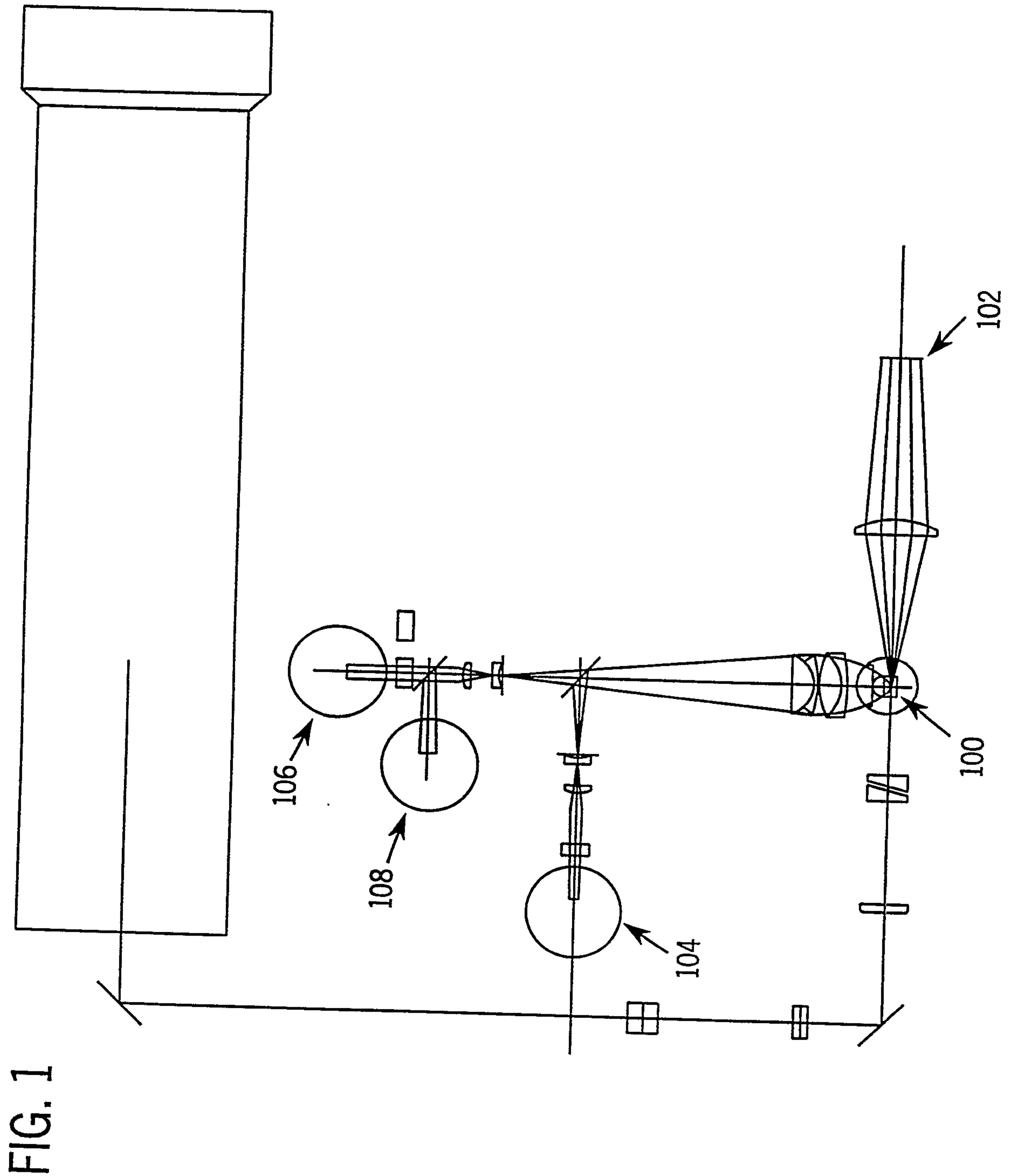

FIG. 2

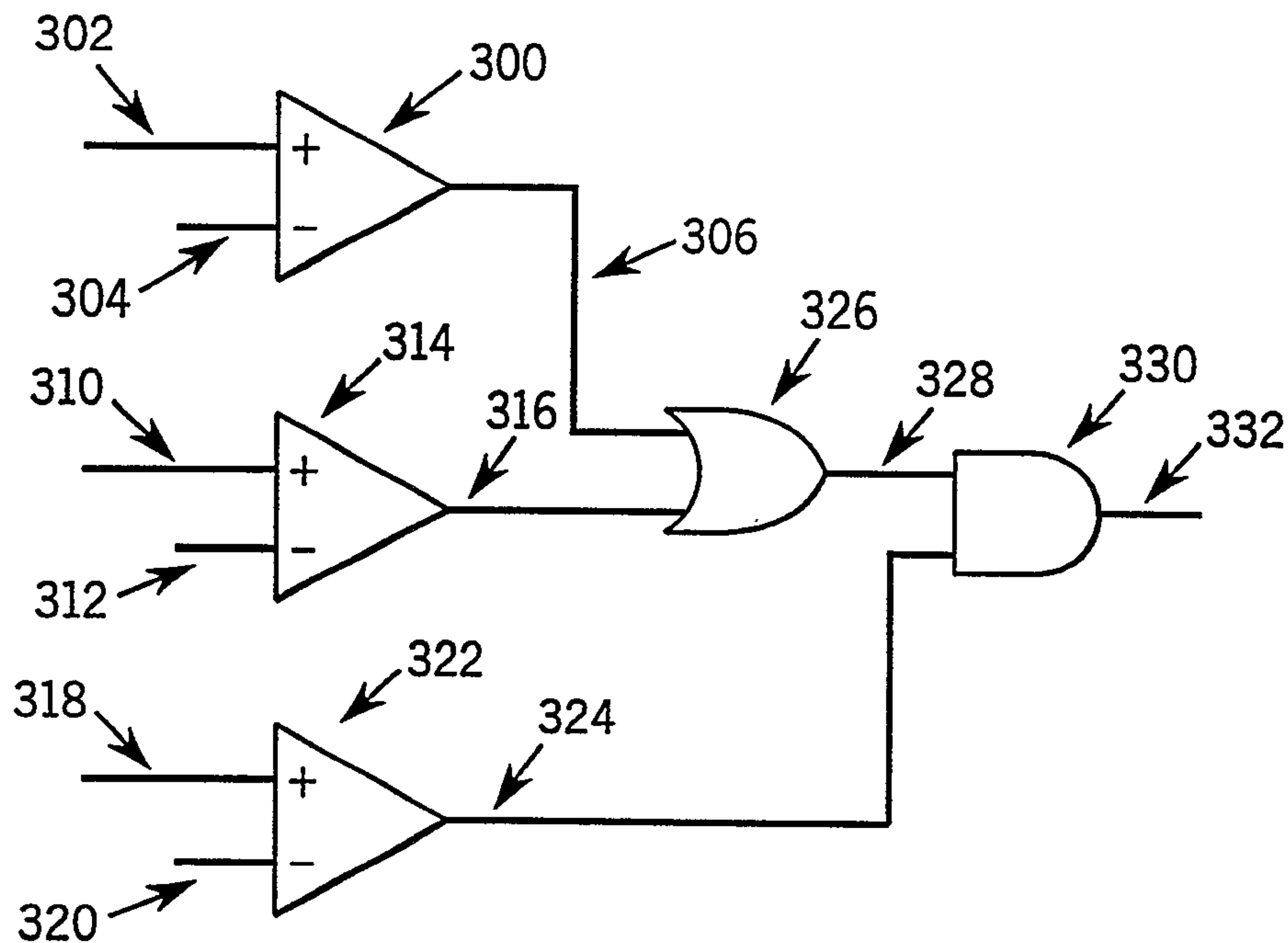

FIG. 17

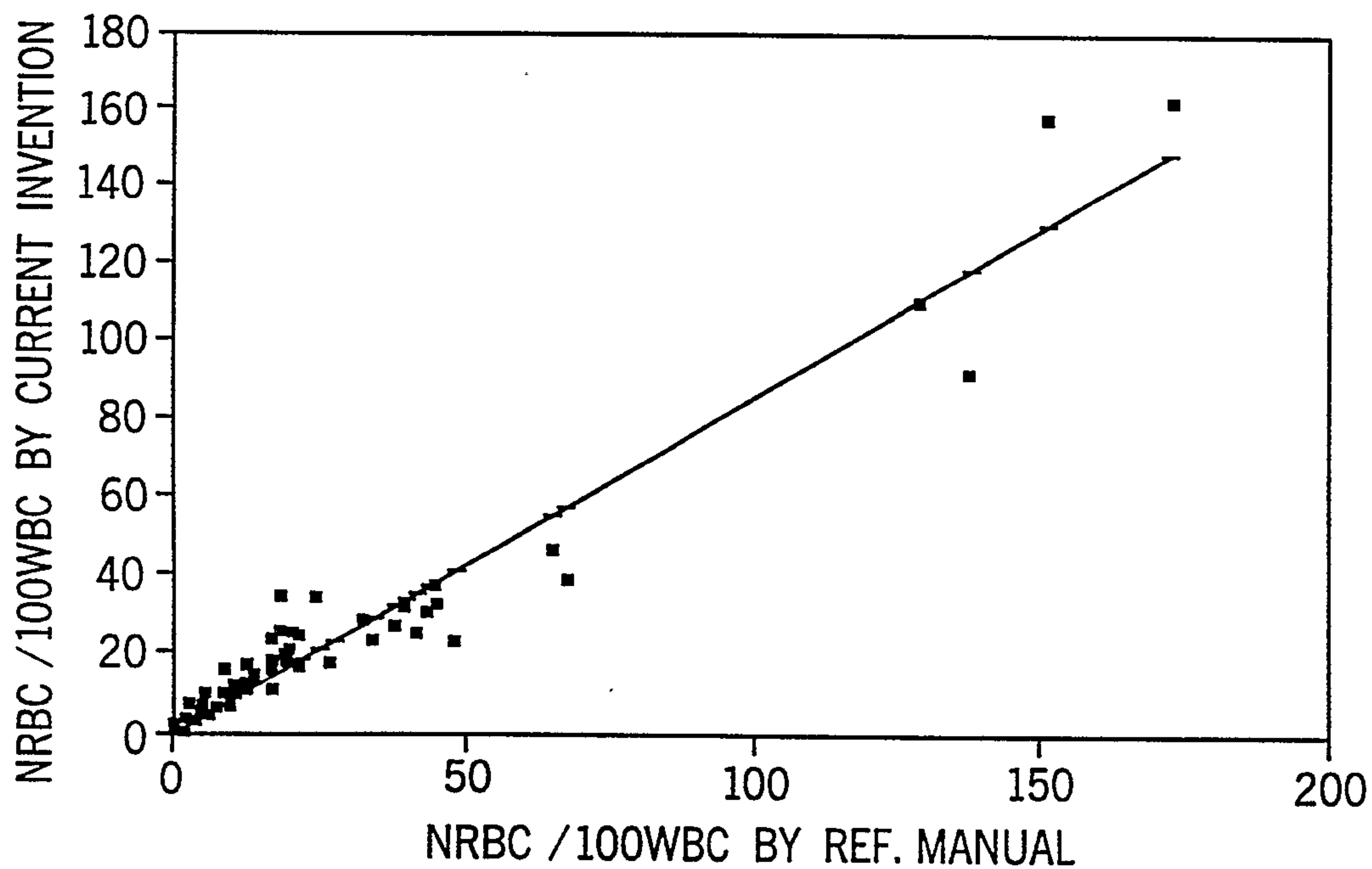

FIG. 3A

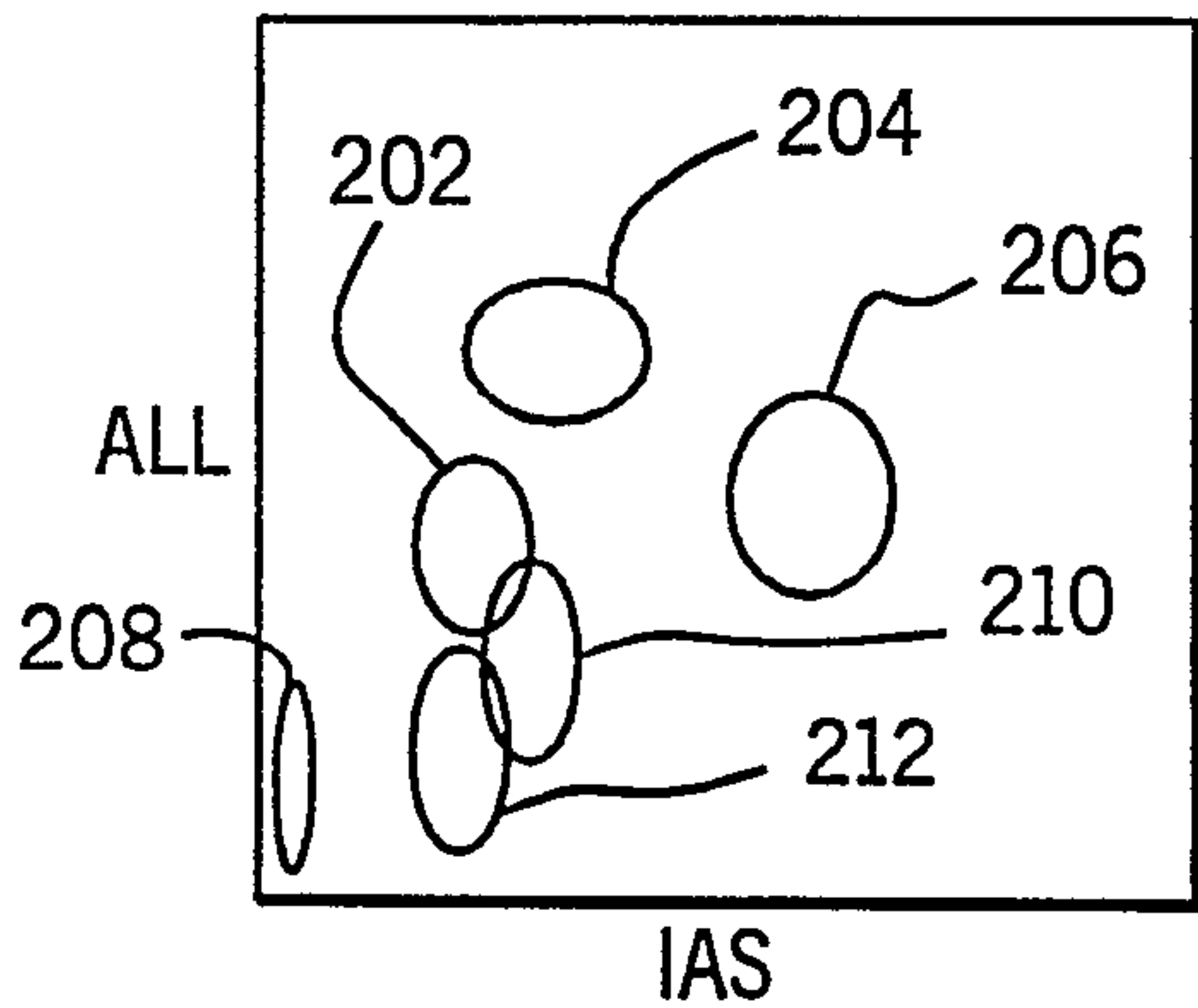

FIG. 4A

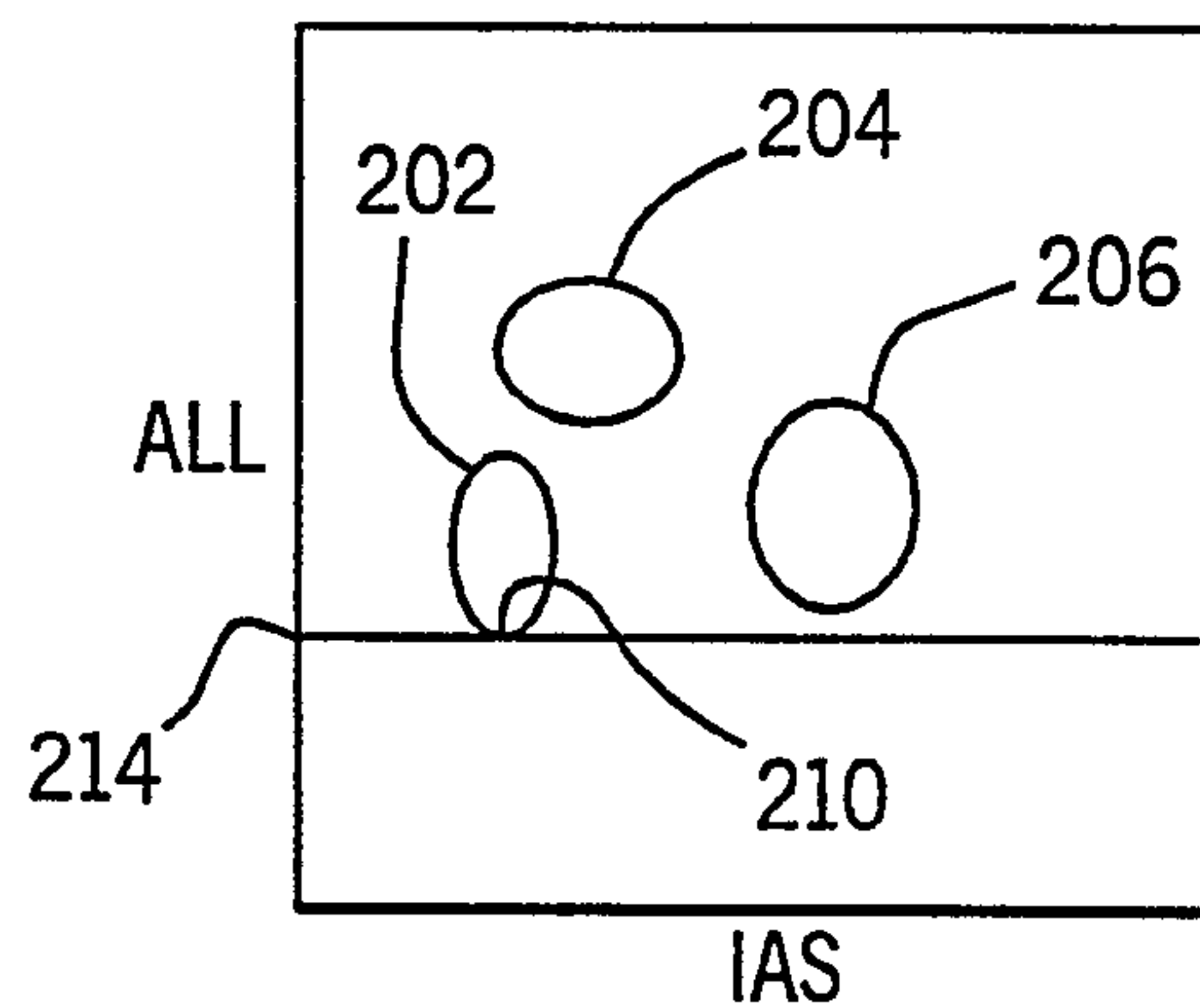

FIG. 3B

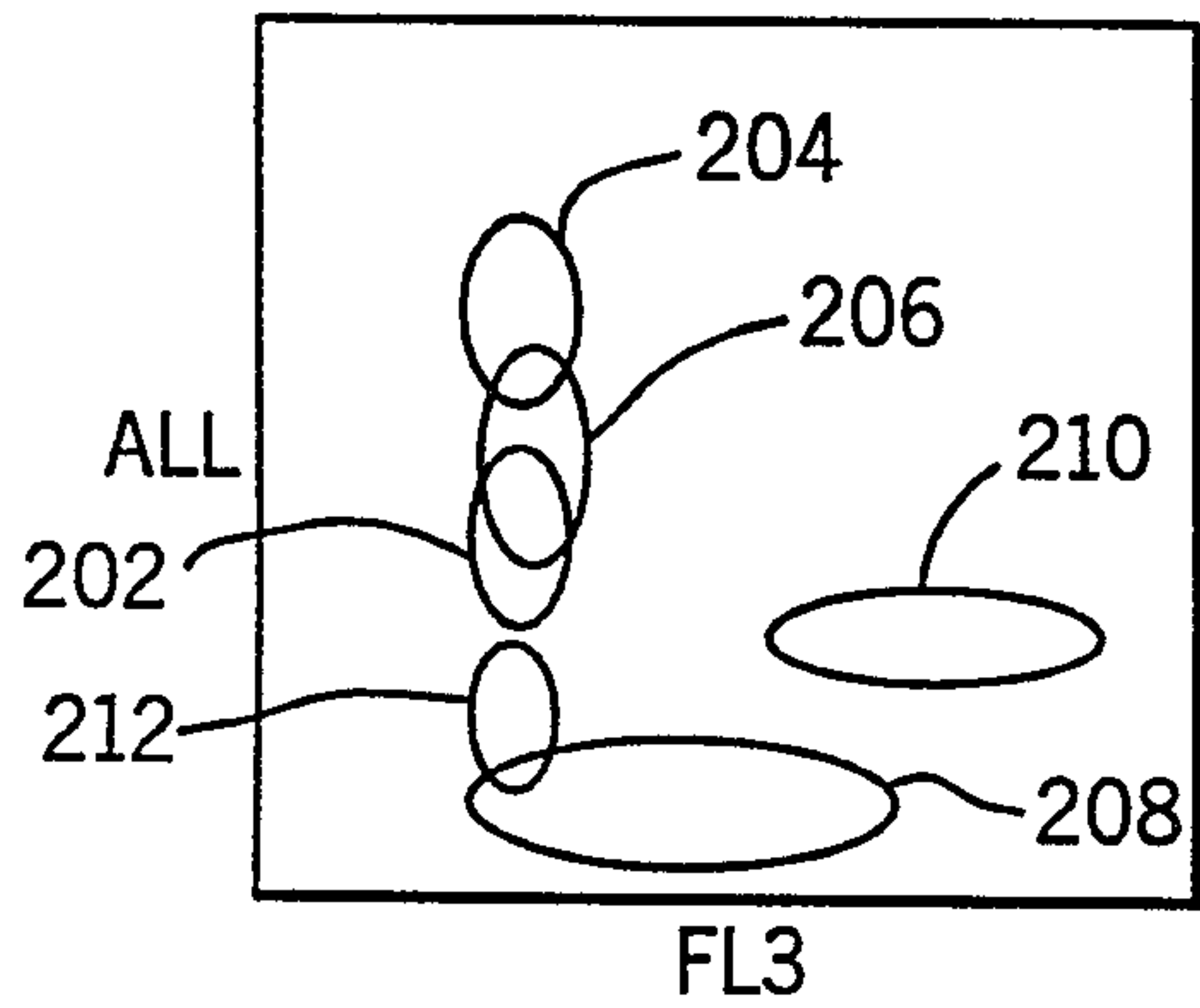

FIG. 4B

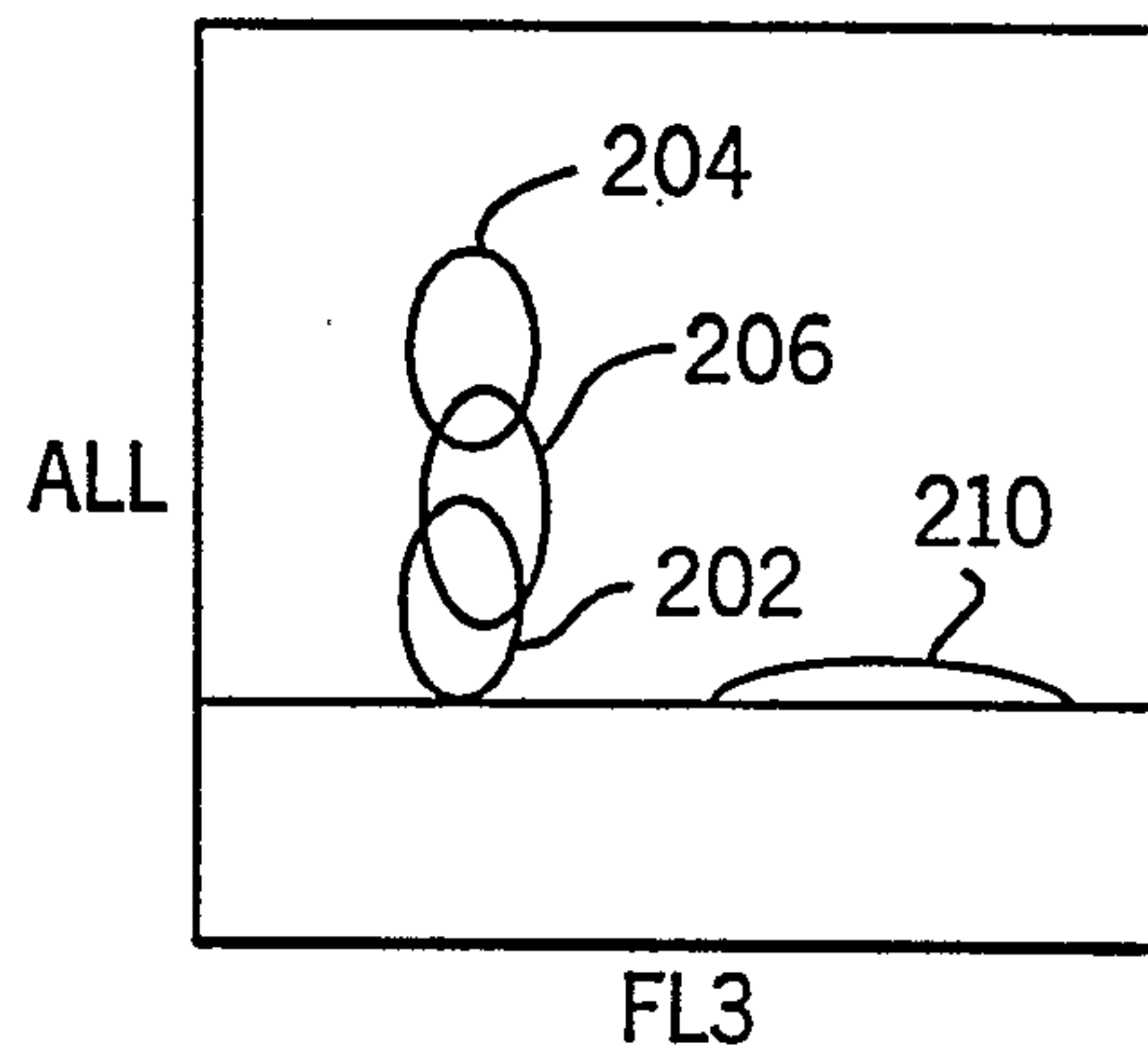

FIG. 3C

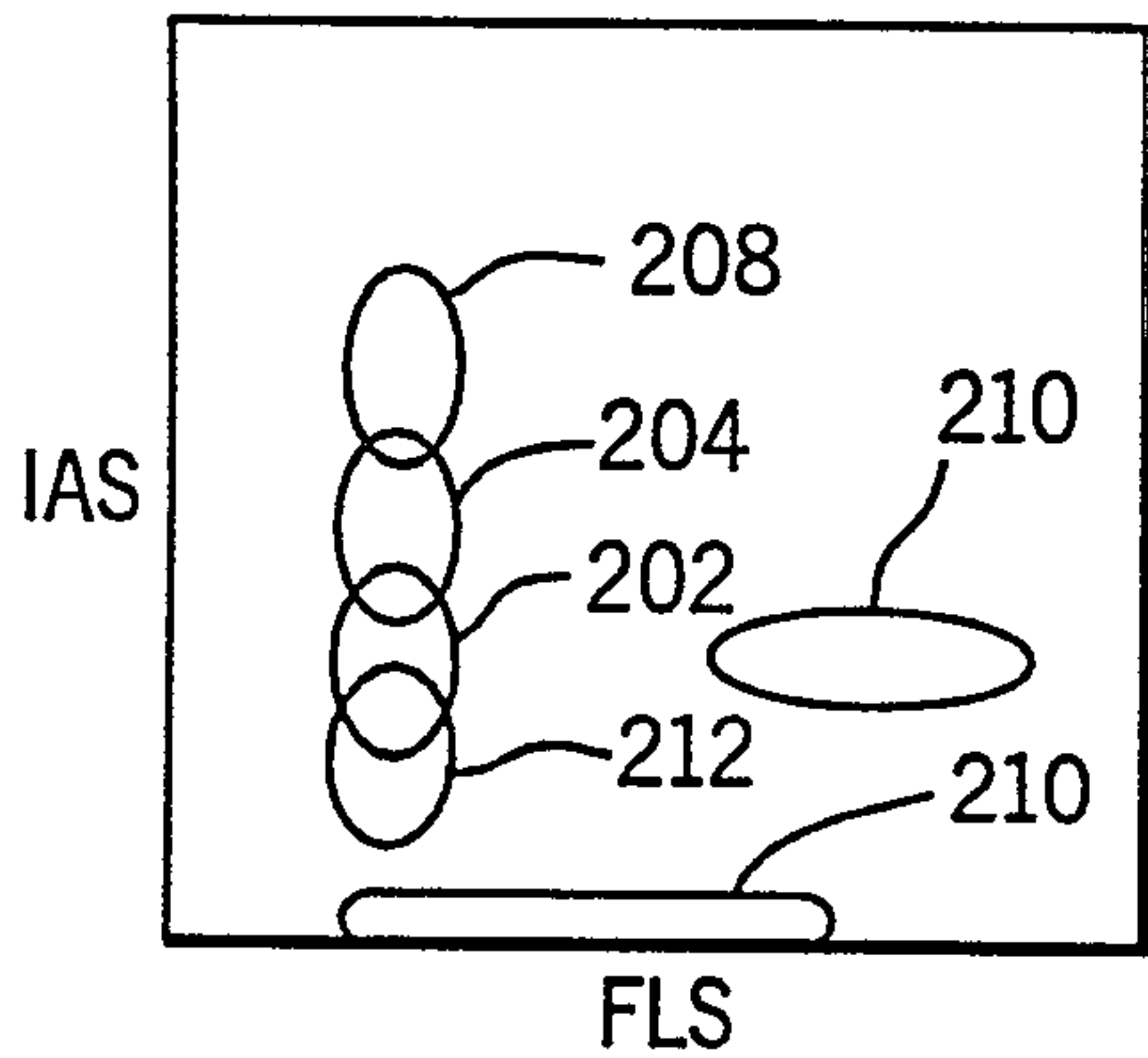

FIG. 4C

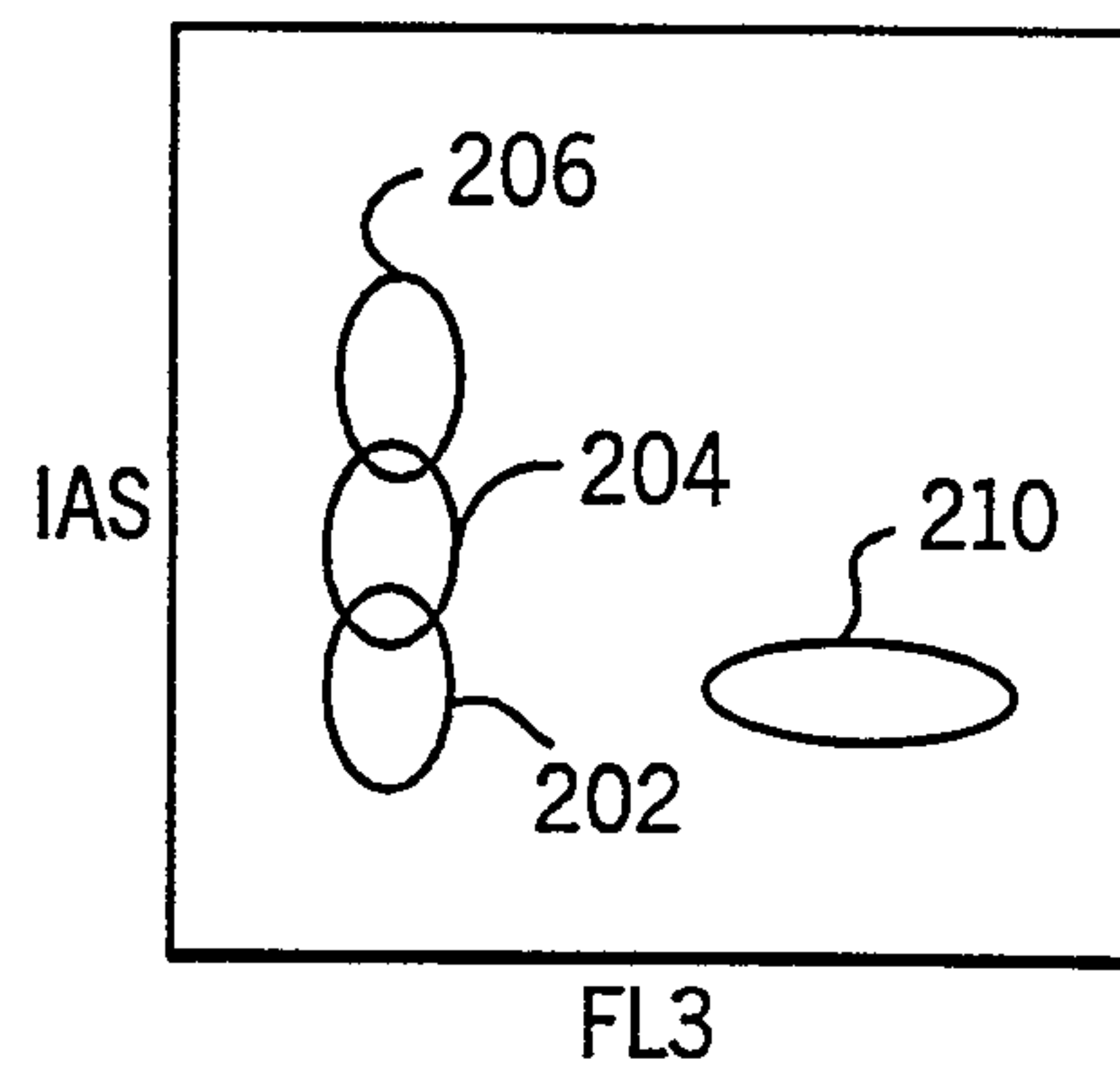

FIG. 5A

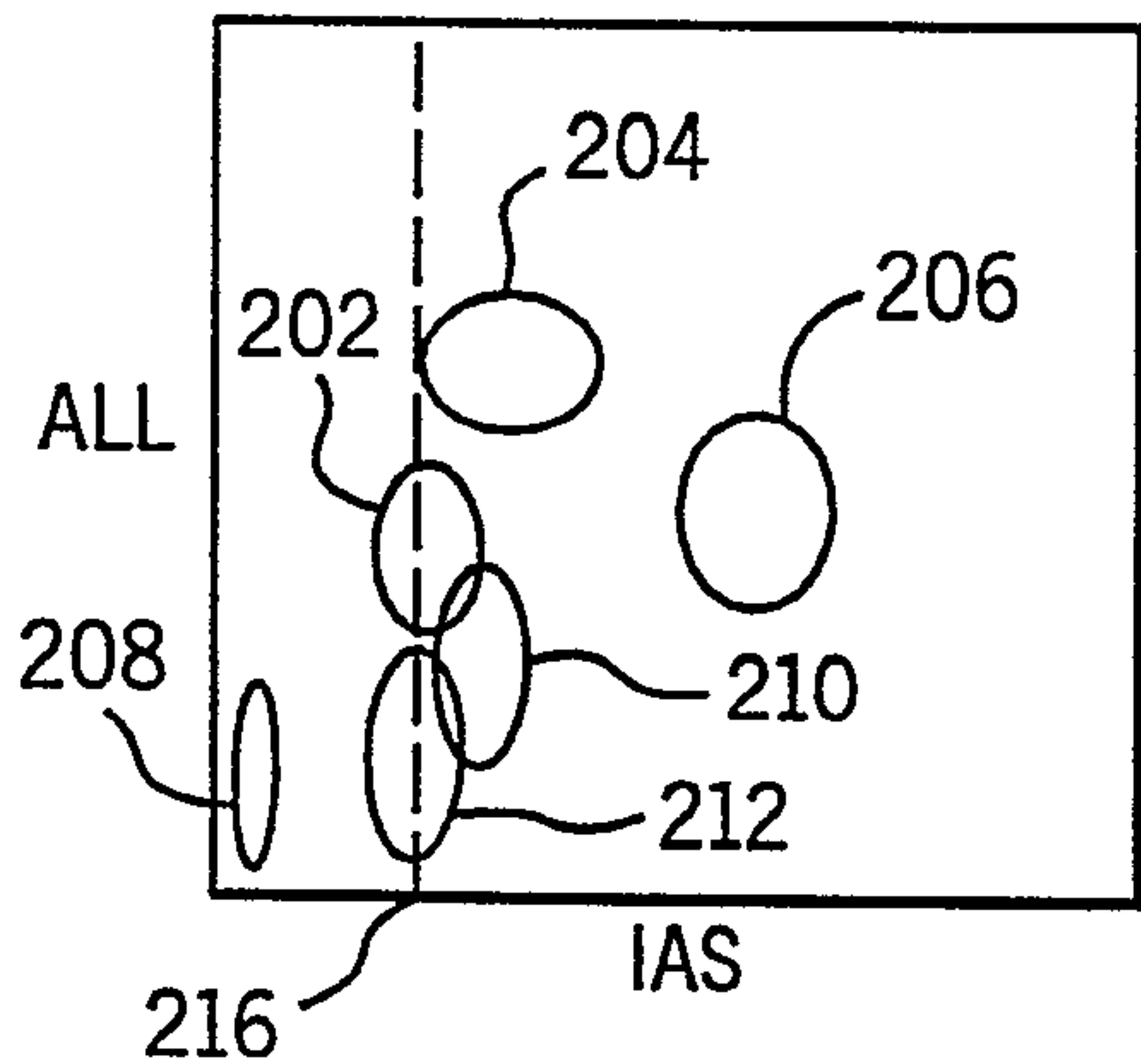

FIG. 6A

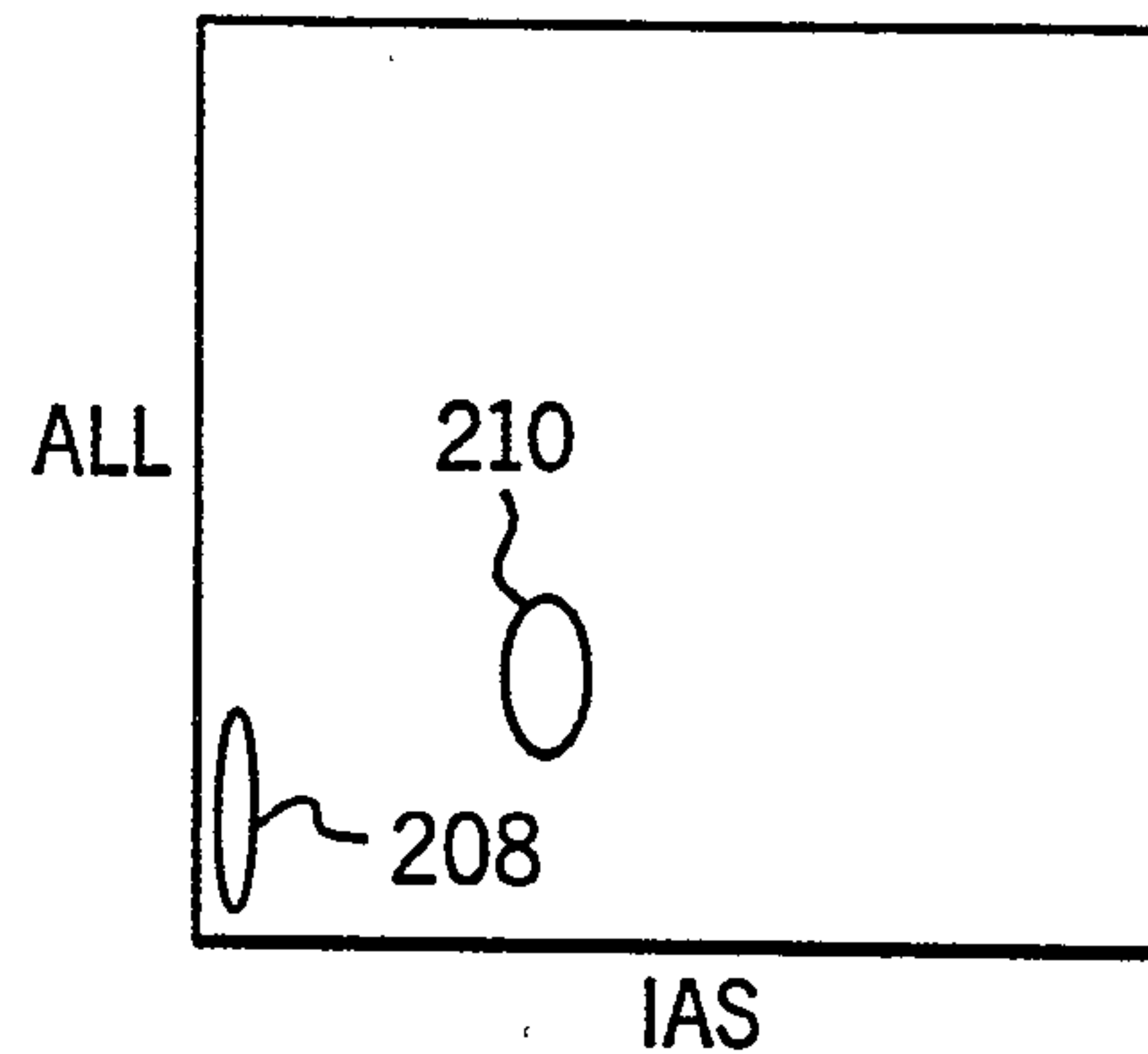

FIG. 5B

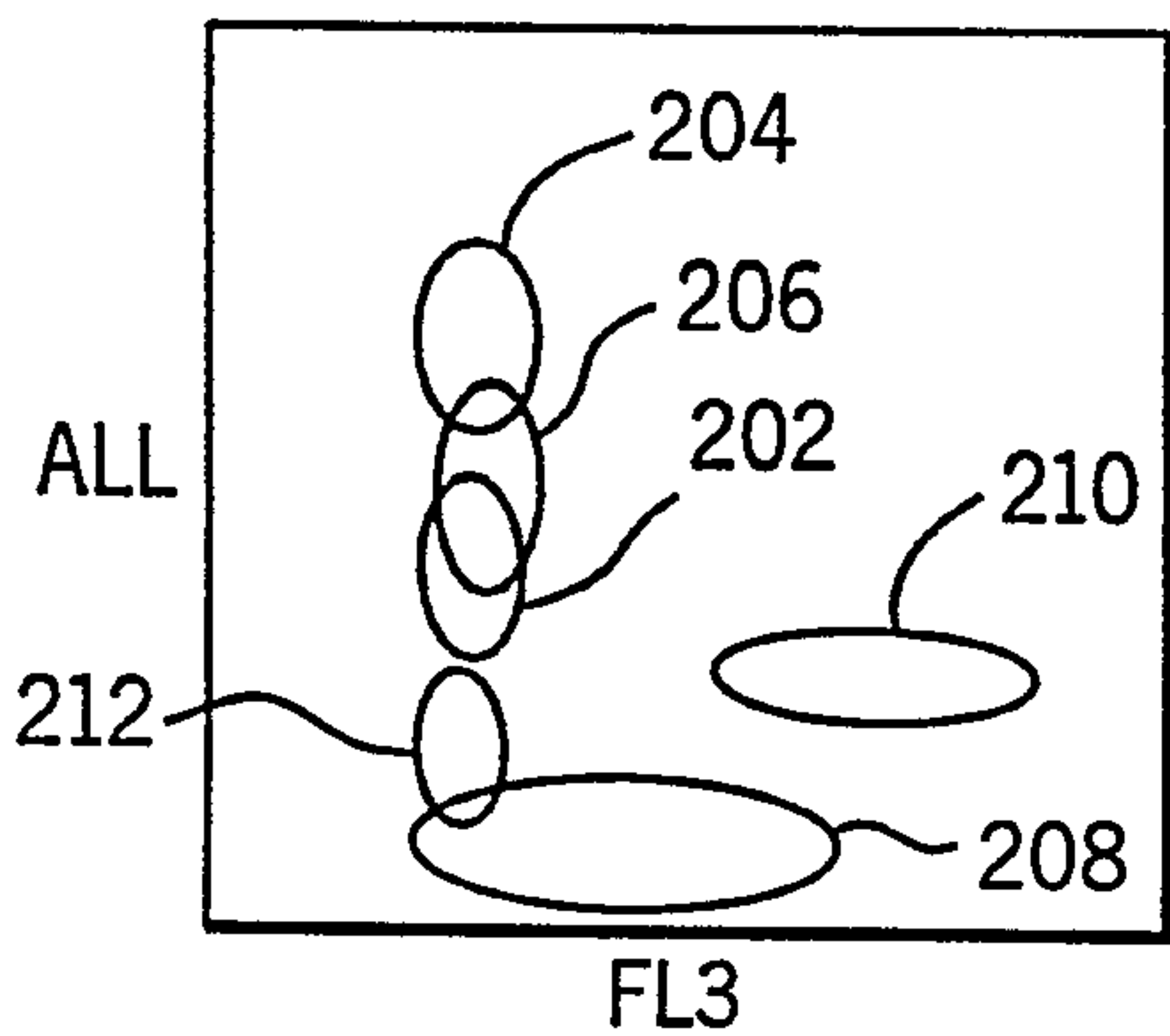

FIG. 6B

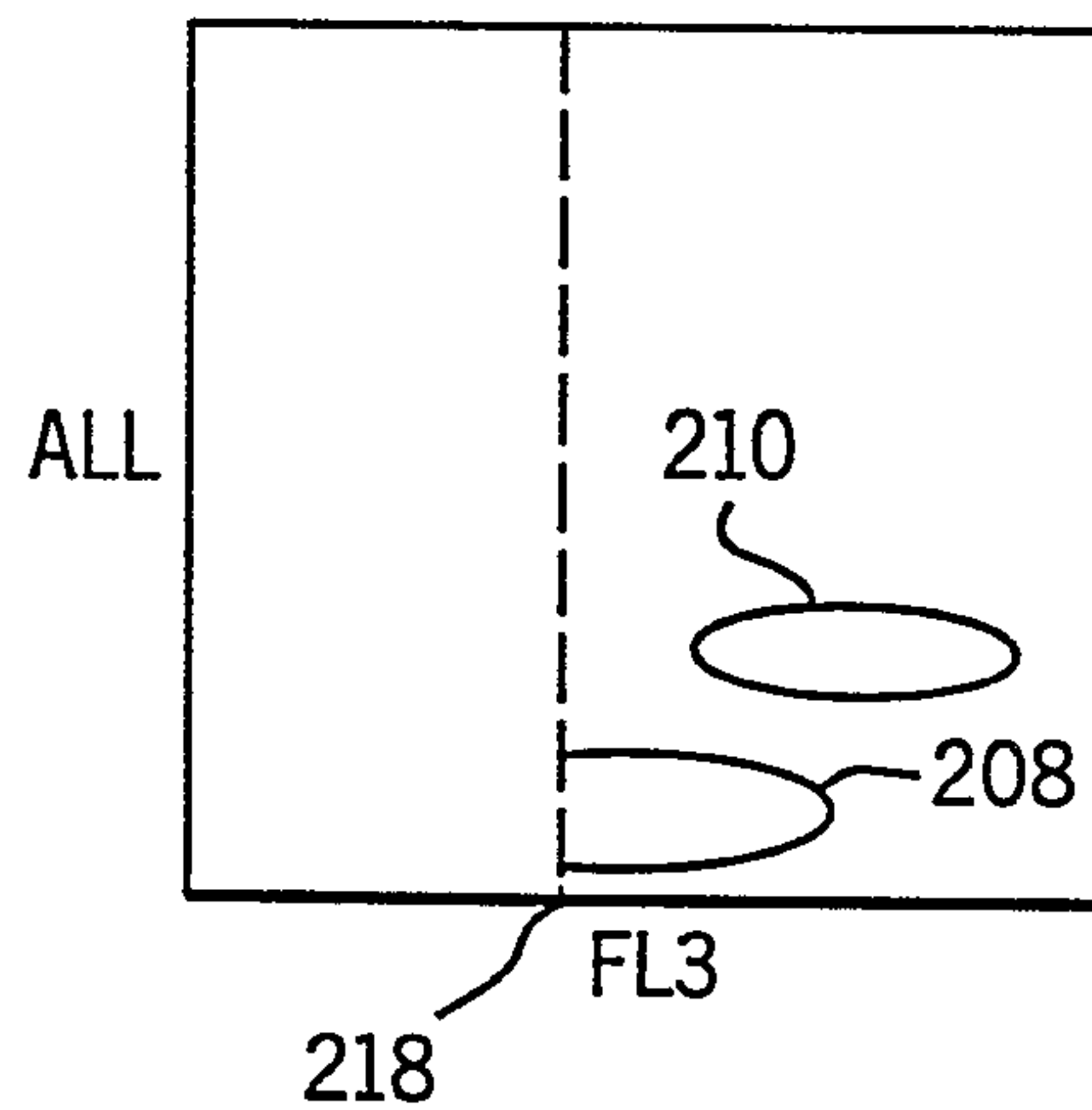

FIG. 5C

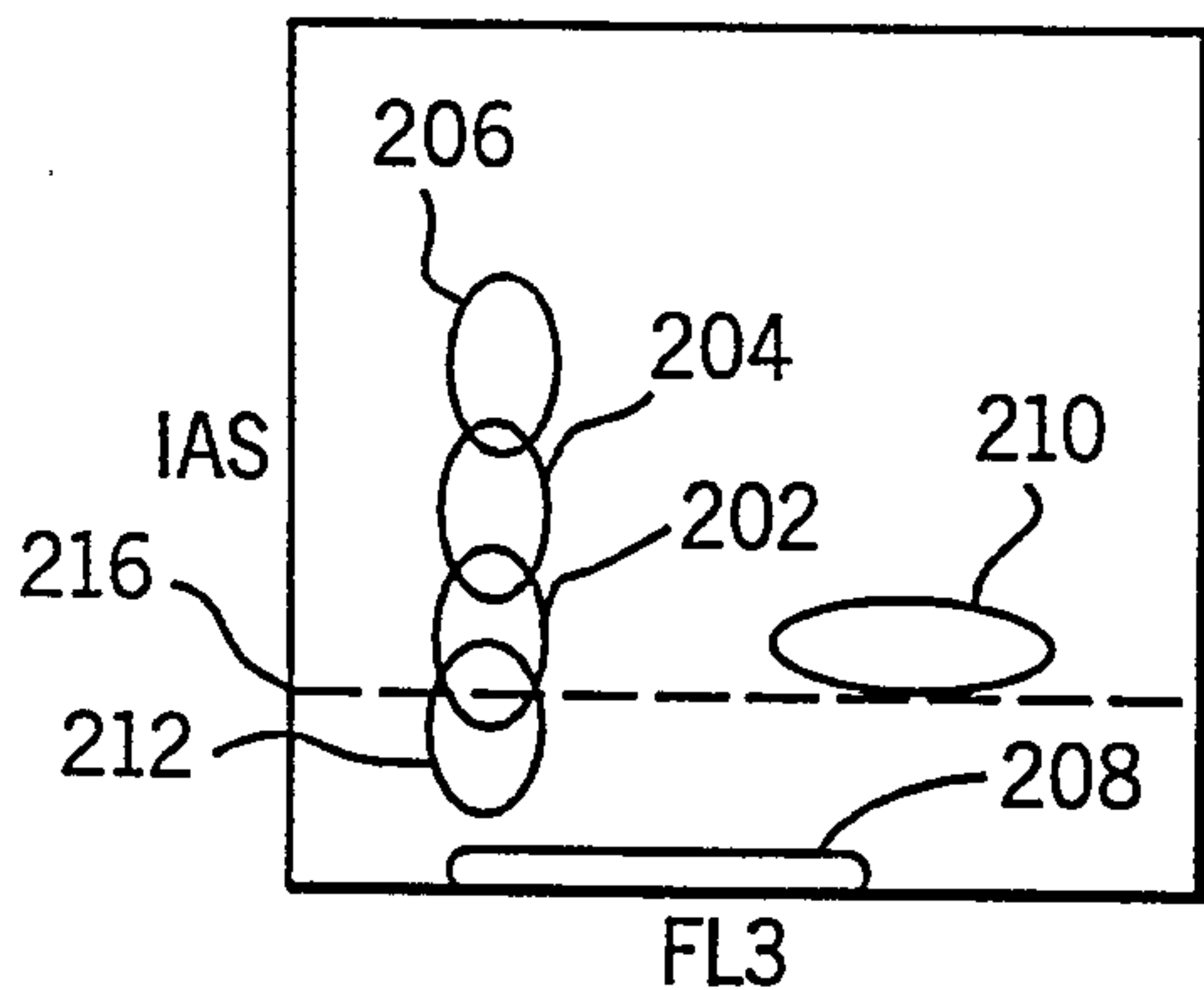

FIG. 6C

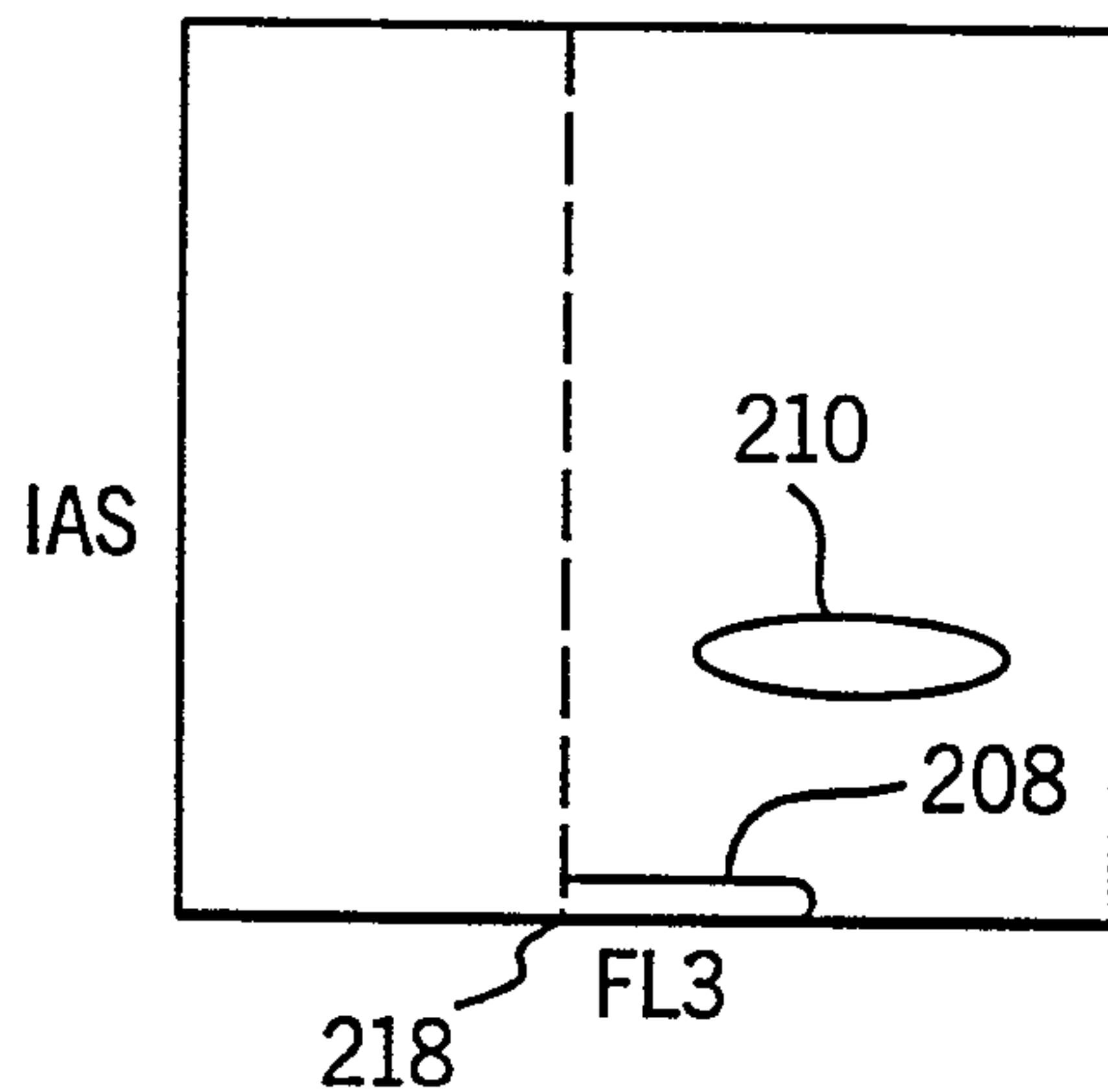

FIG. 7A

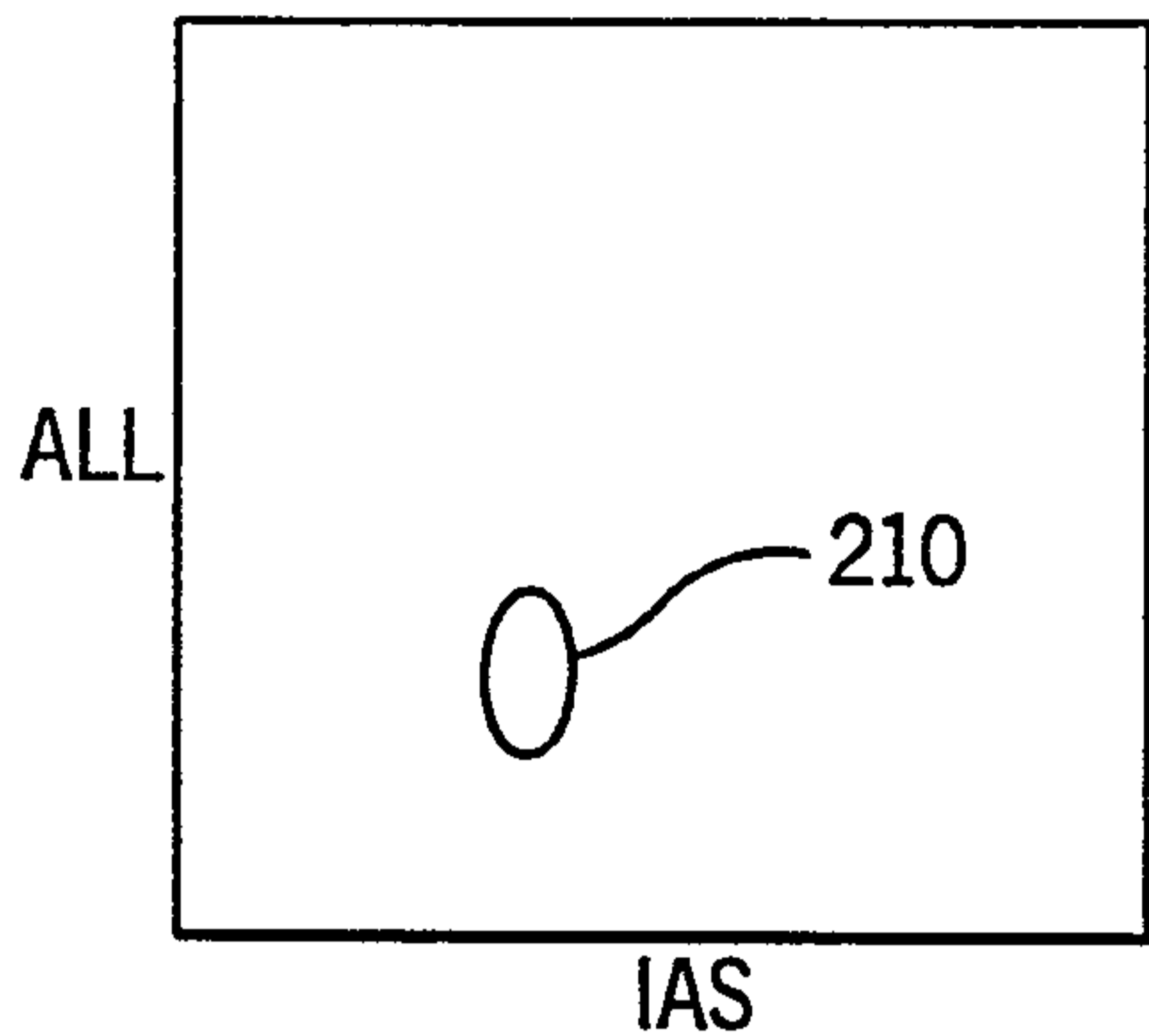

FIG. 8A

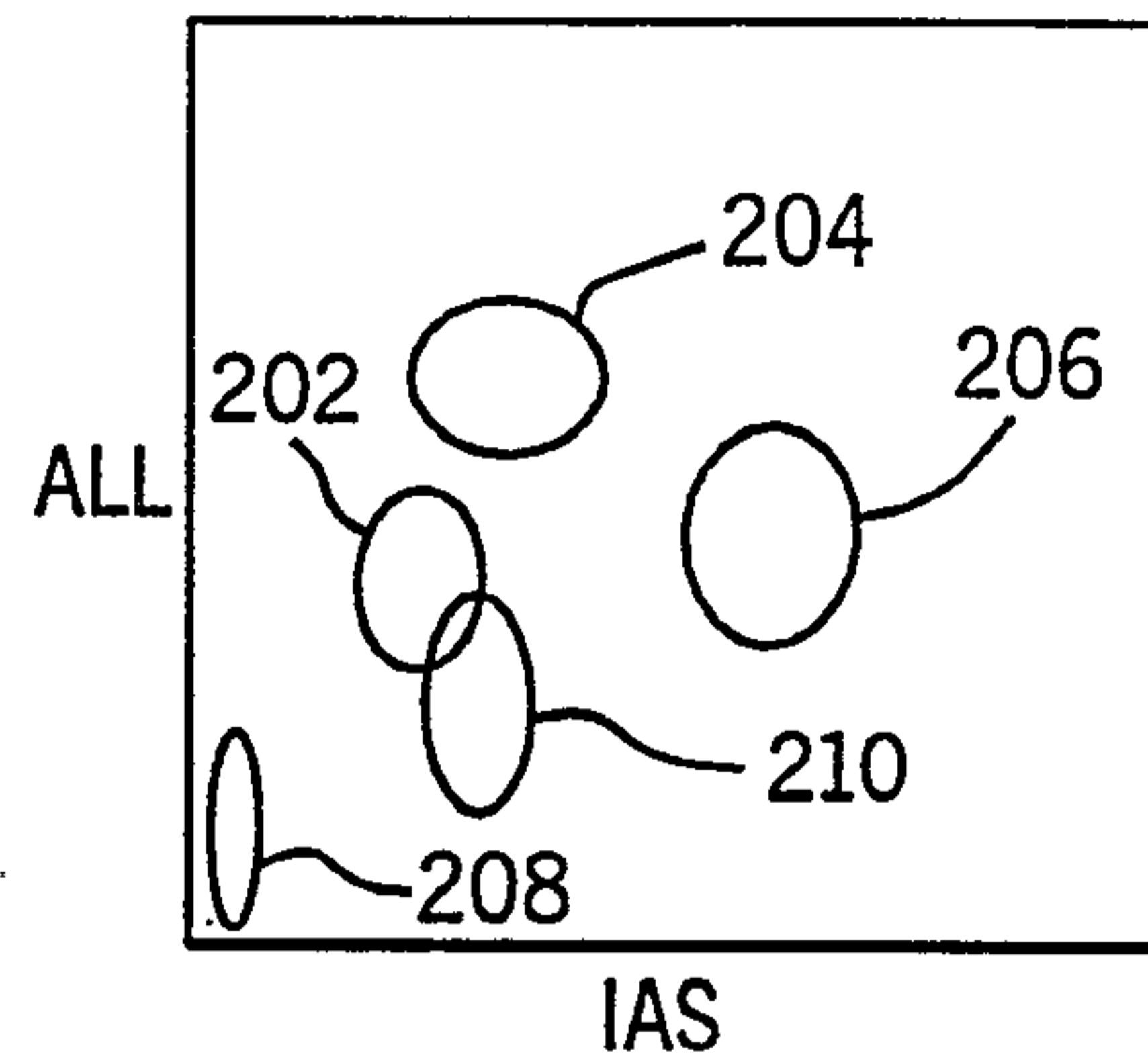

FIG. 7B

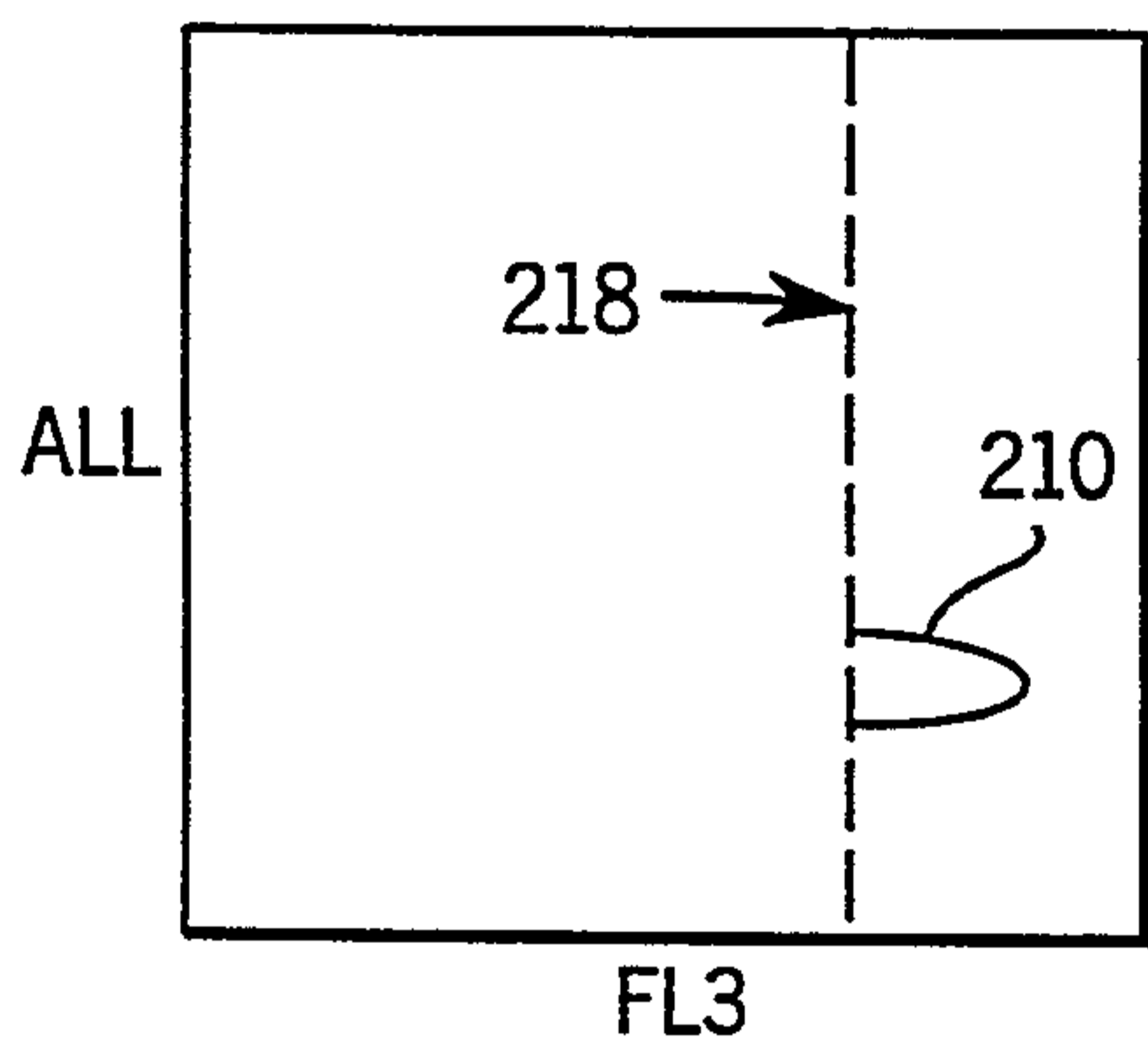

FIG. 8B

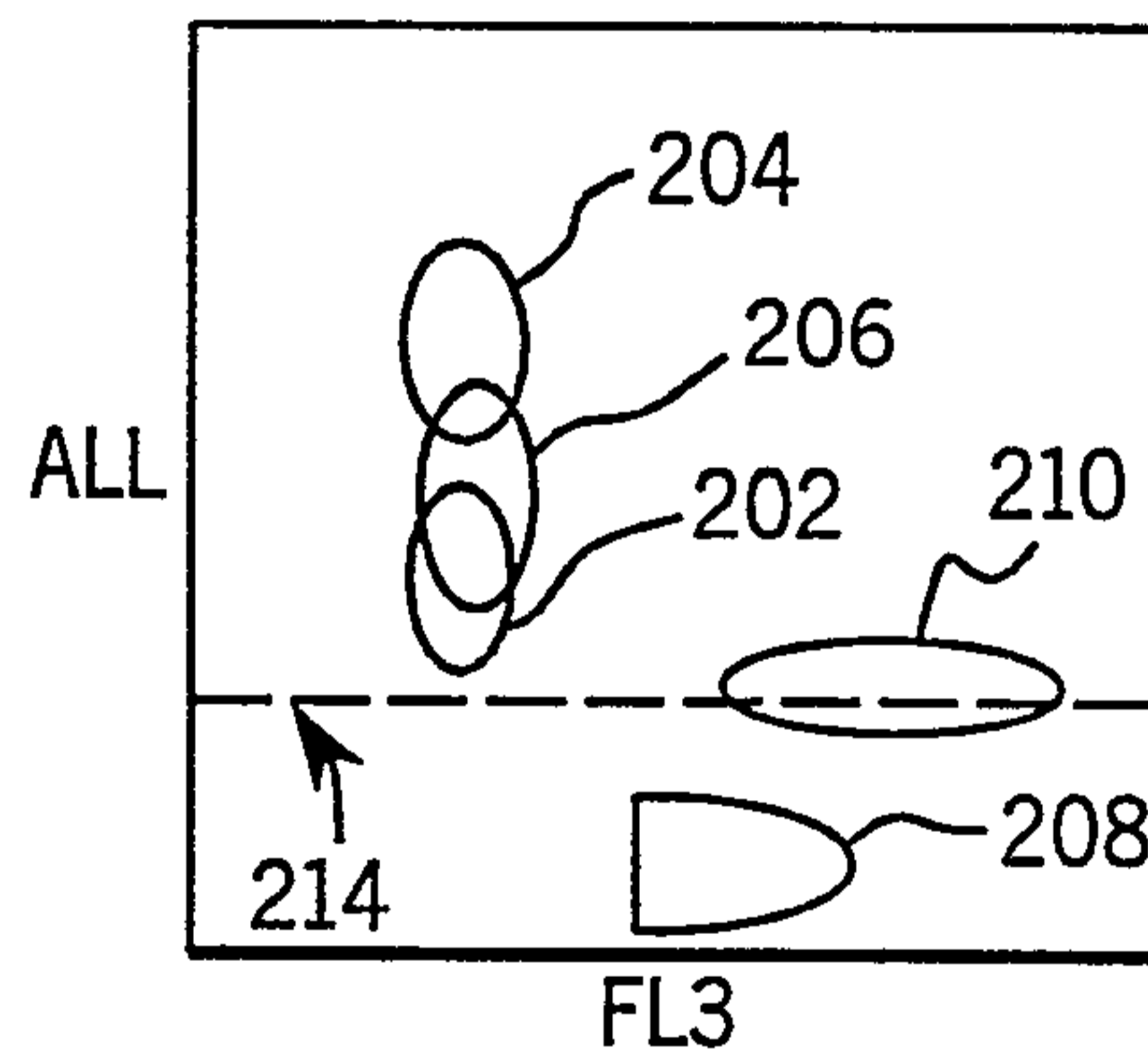

FIG. 7C

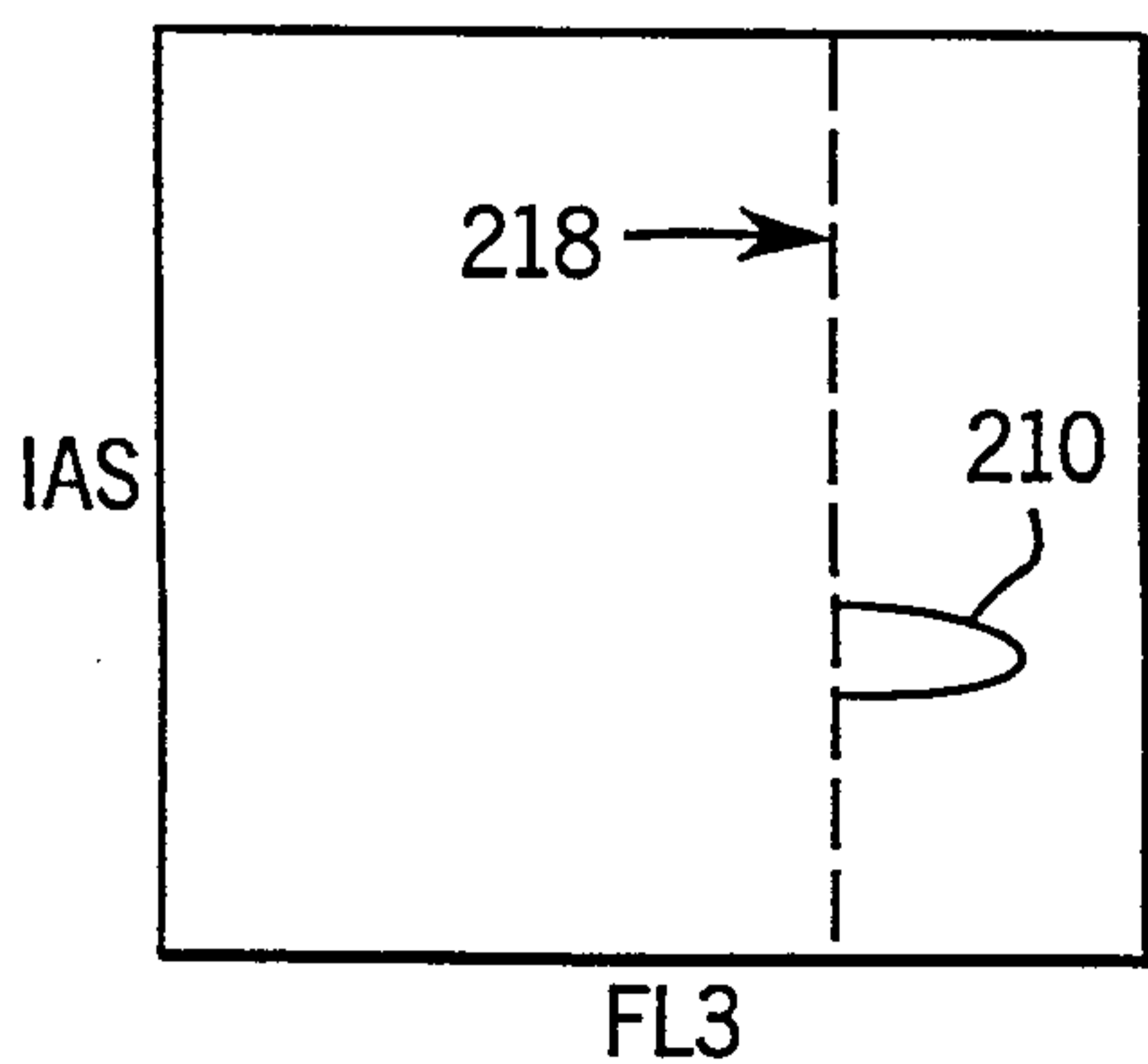
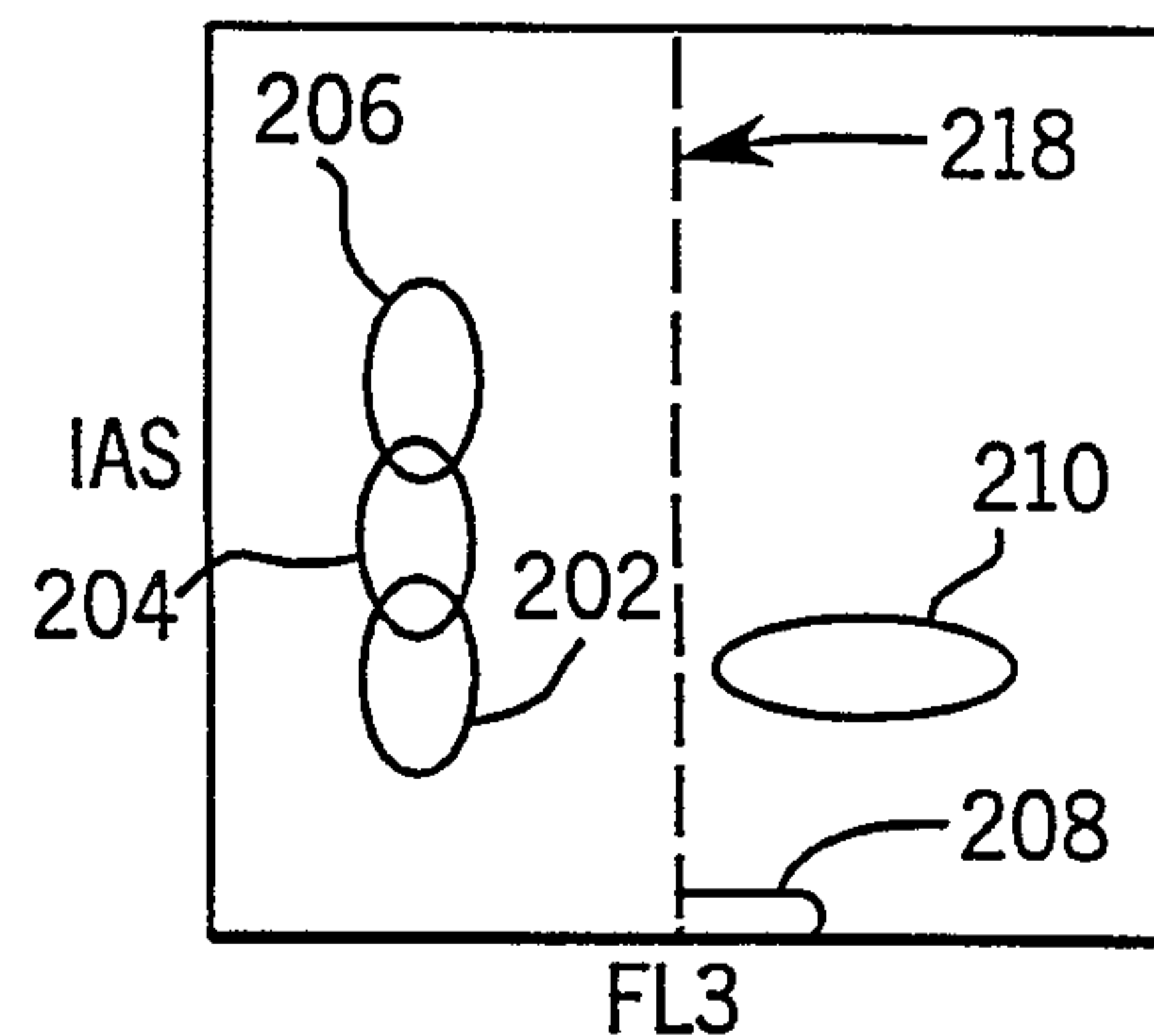

FIG. 8C



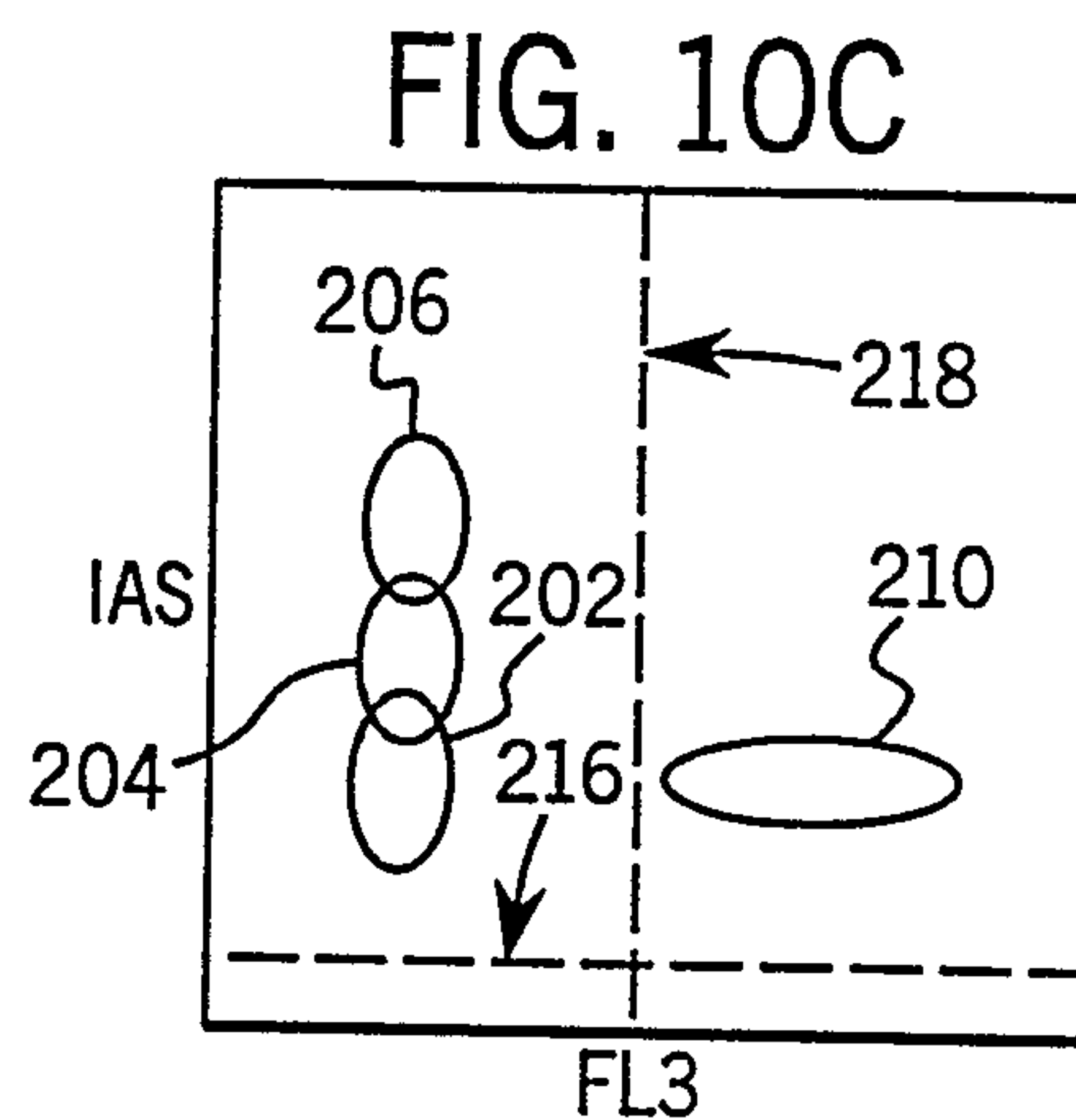
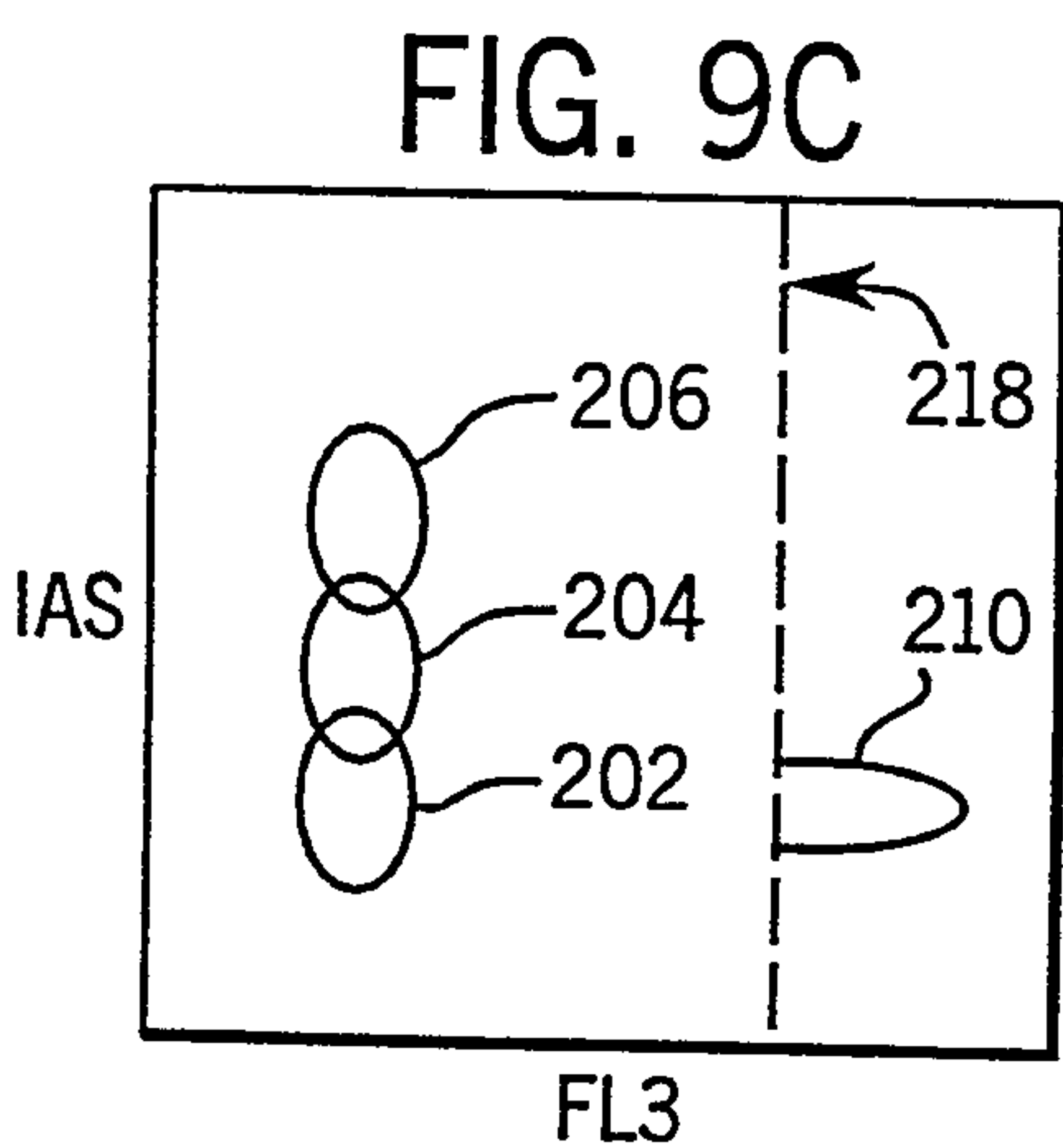
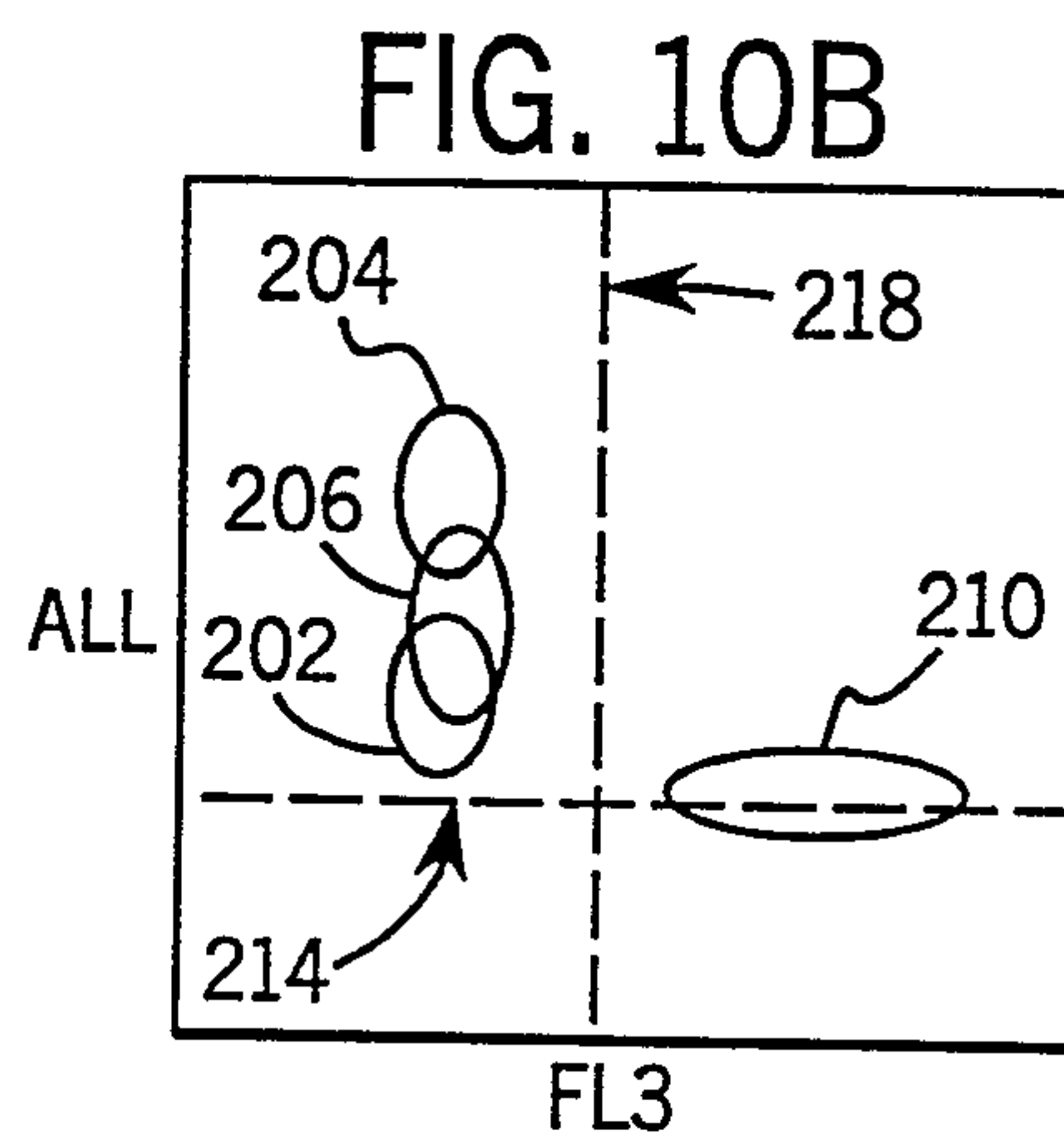
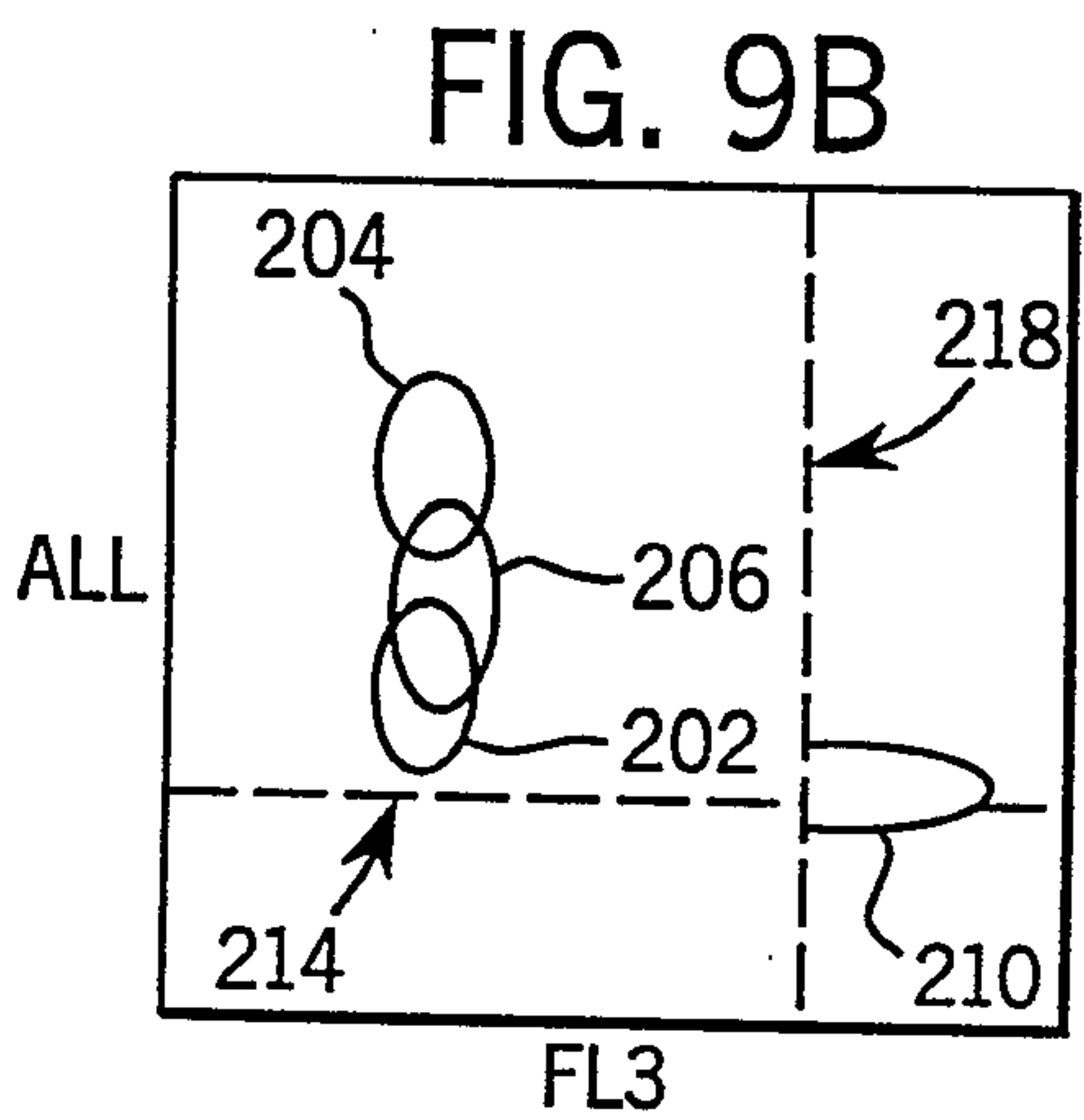
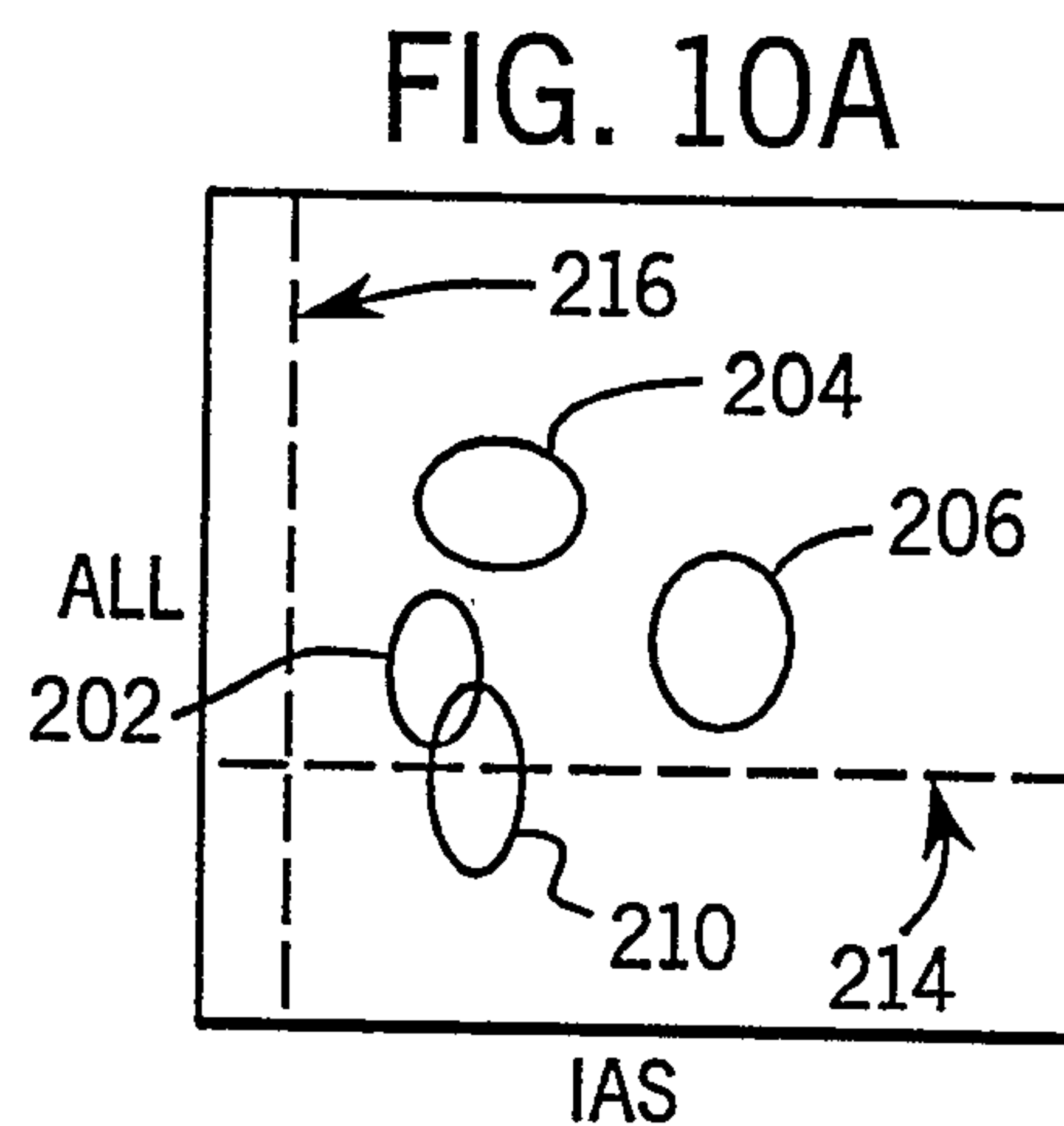
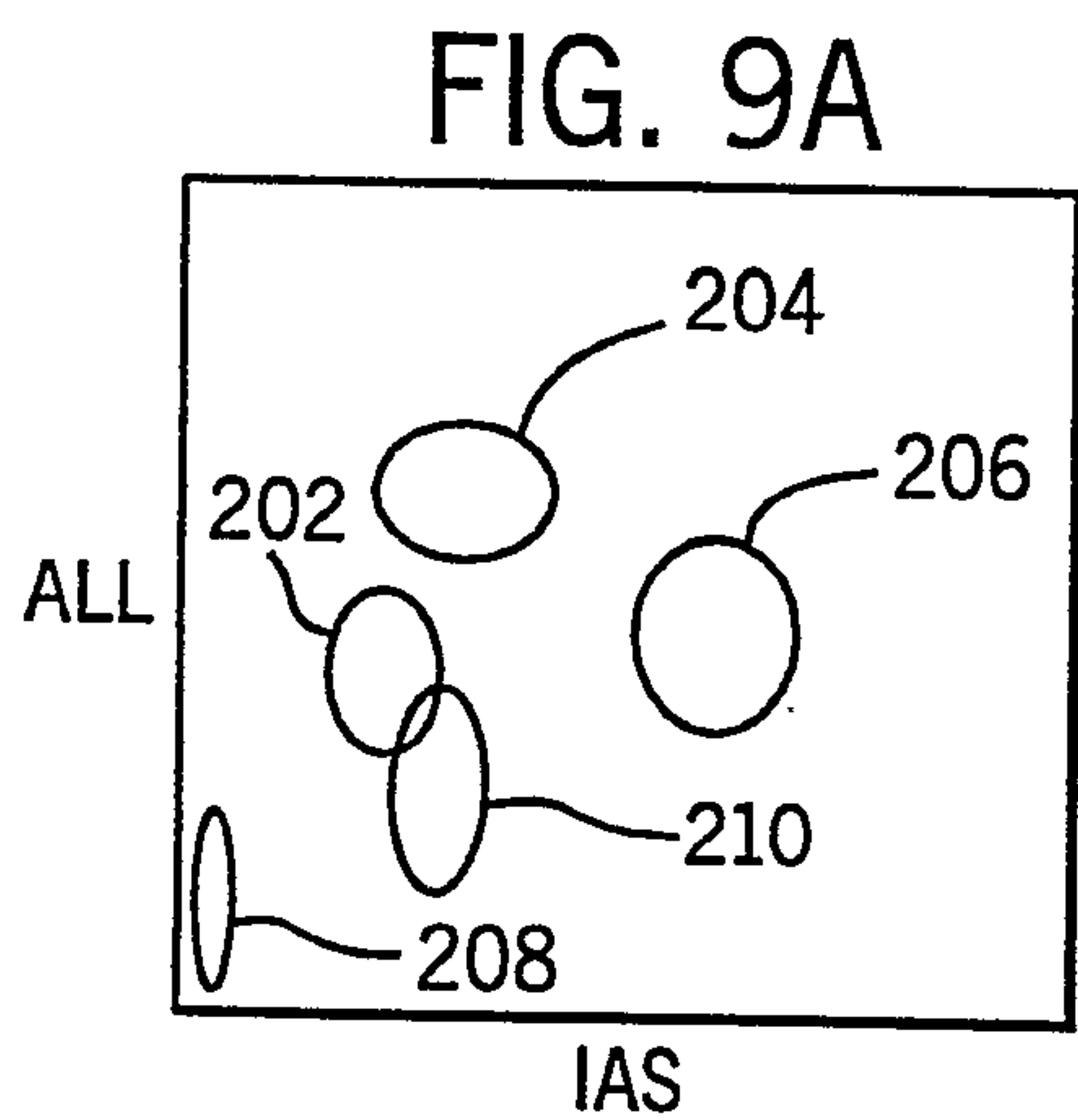

FIG. 11A

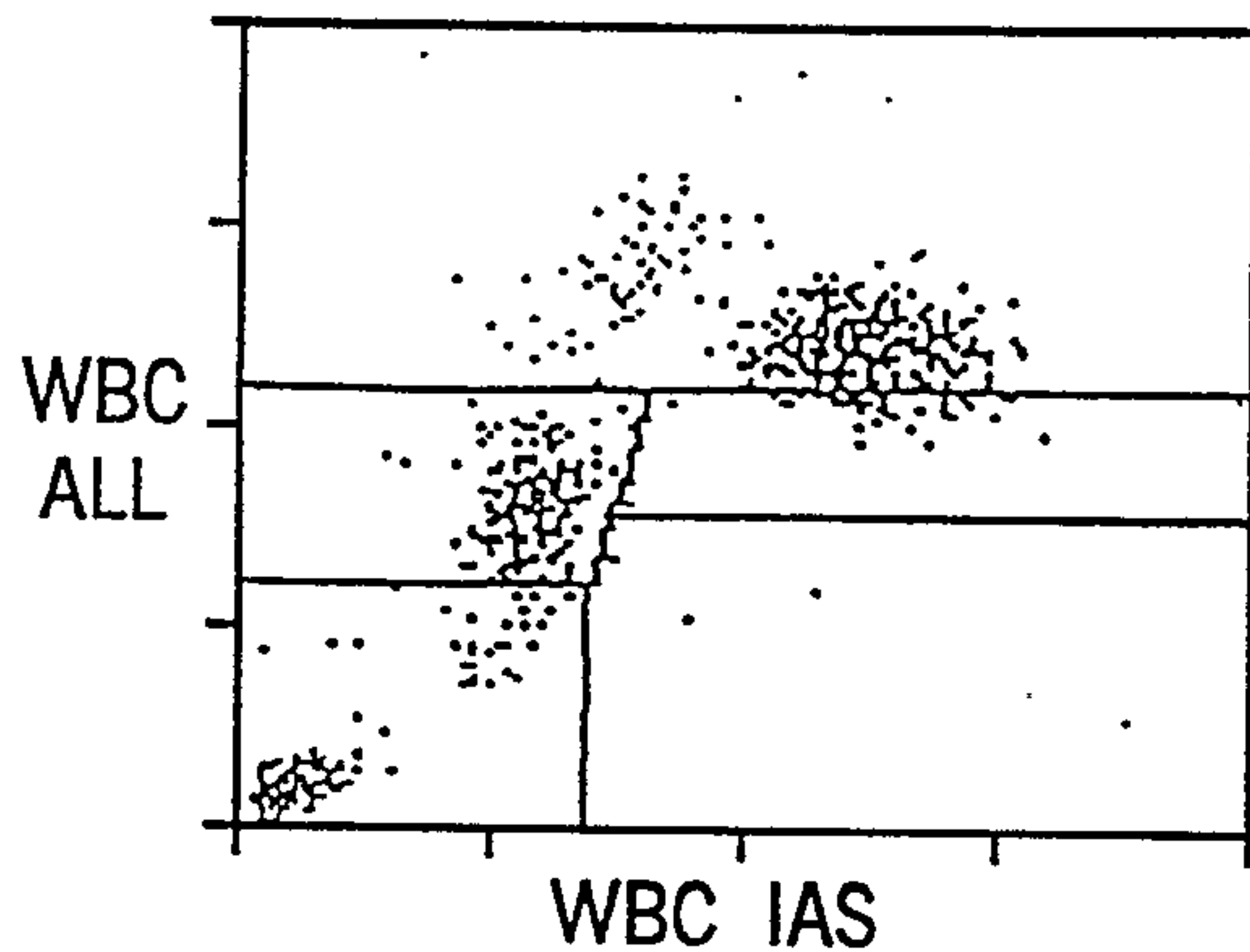

FIG. 12A

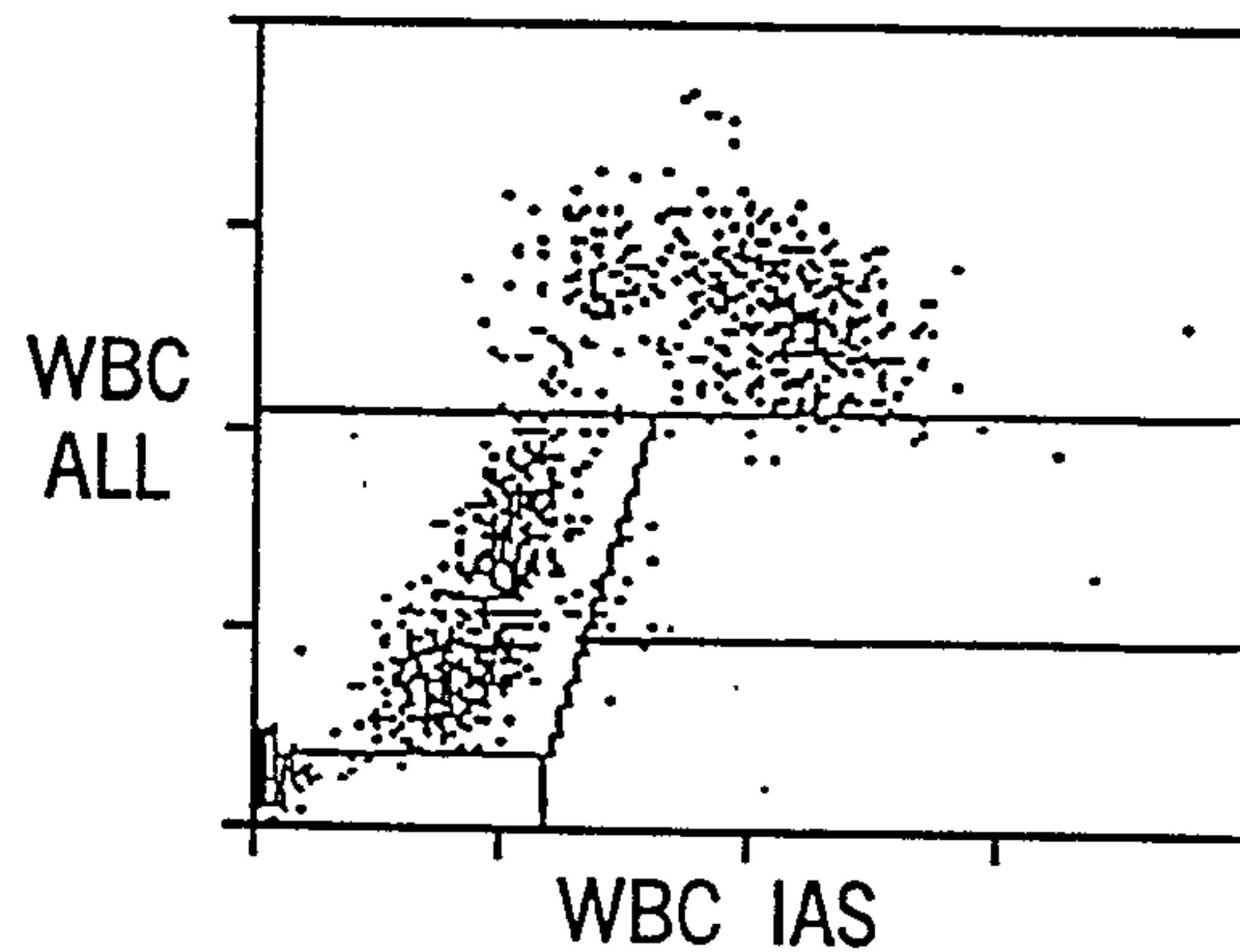

FIG. 11B

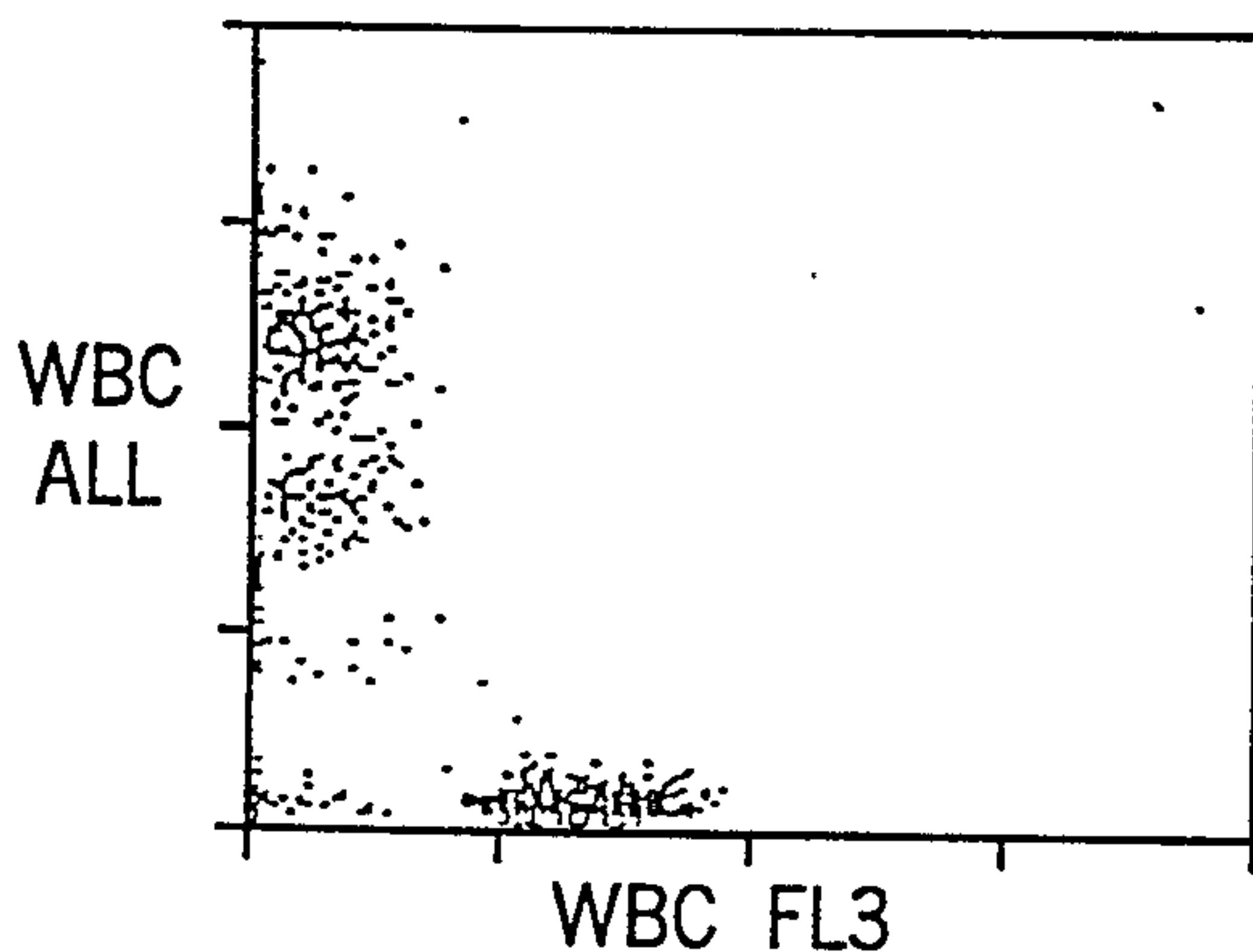

FIG. 12B

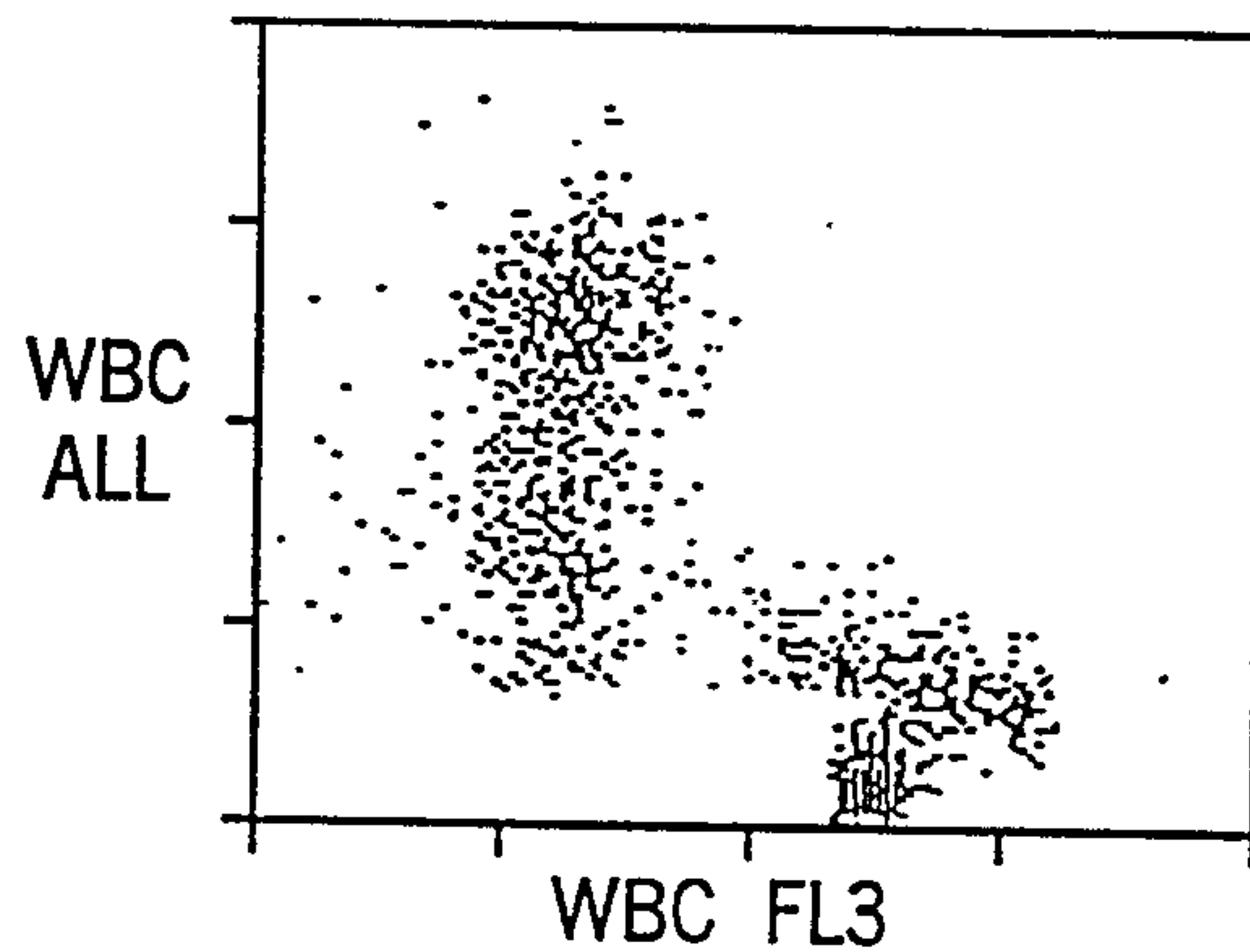

FIG. 11C

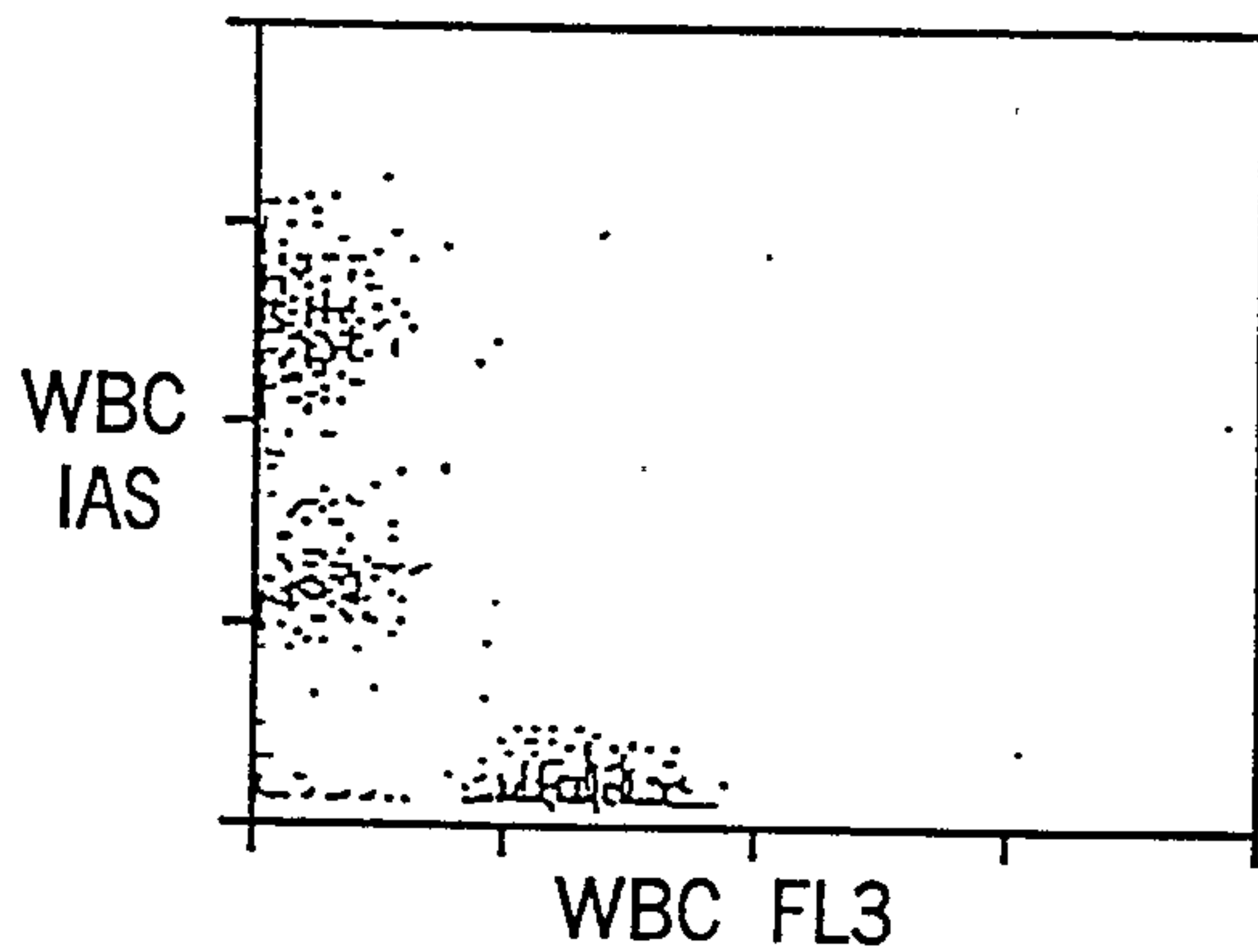

FIG. 13A

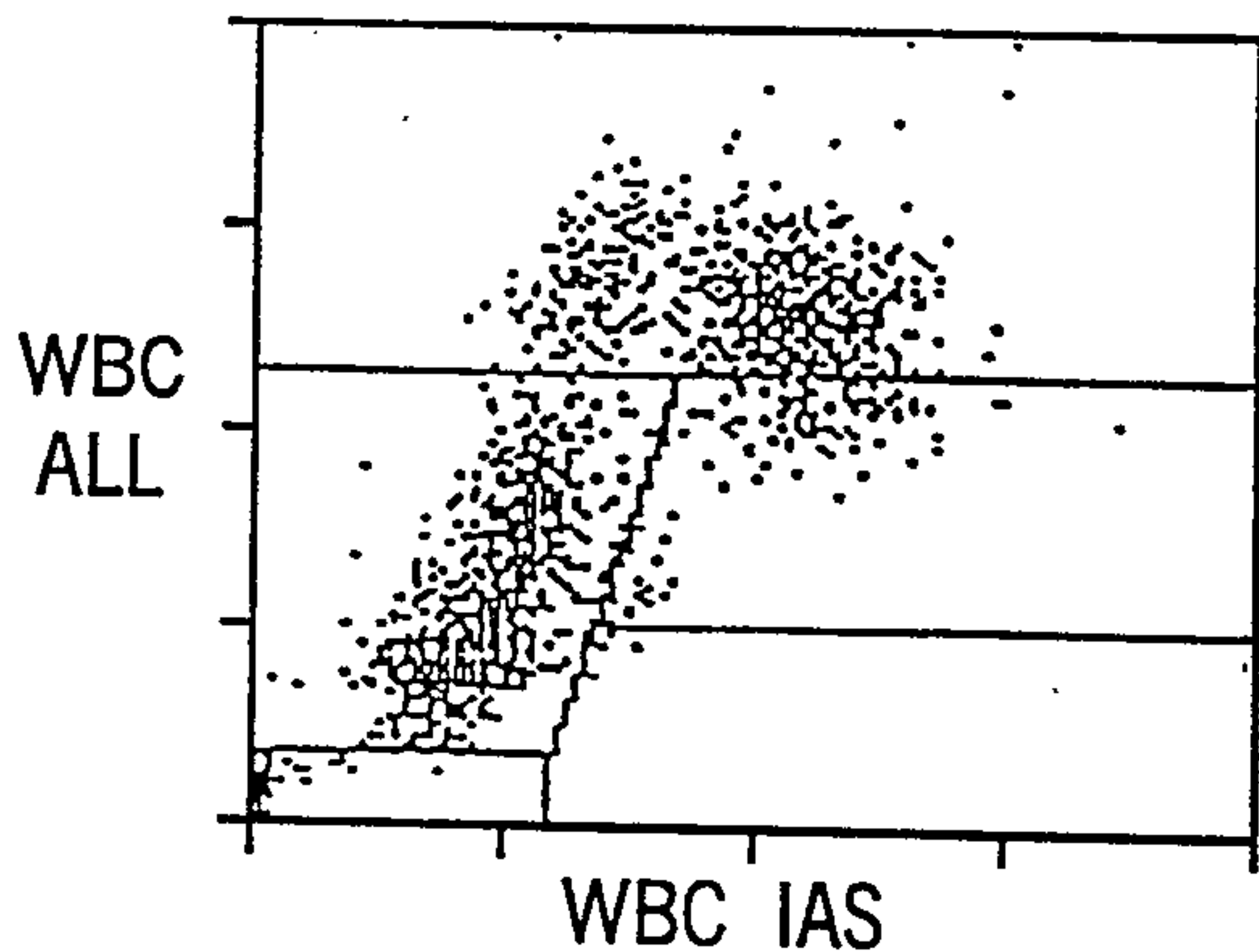

FIG. 13B

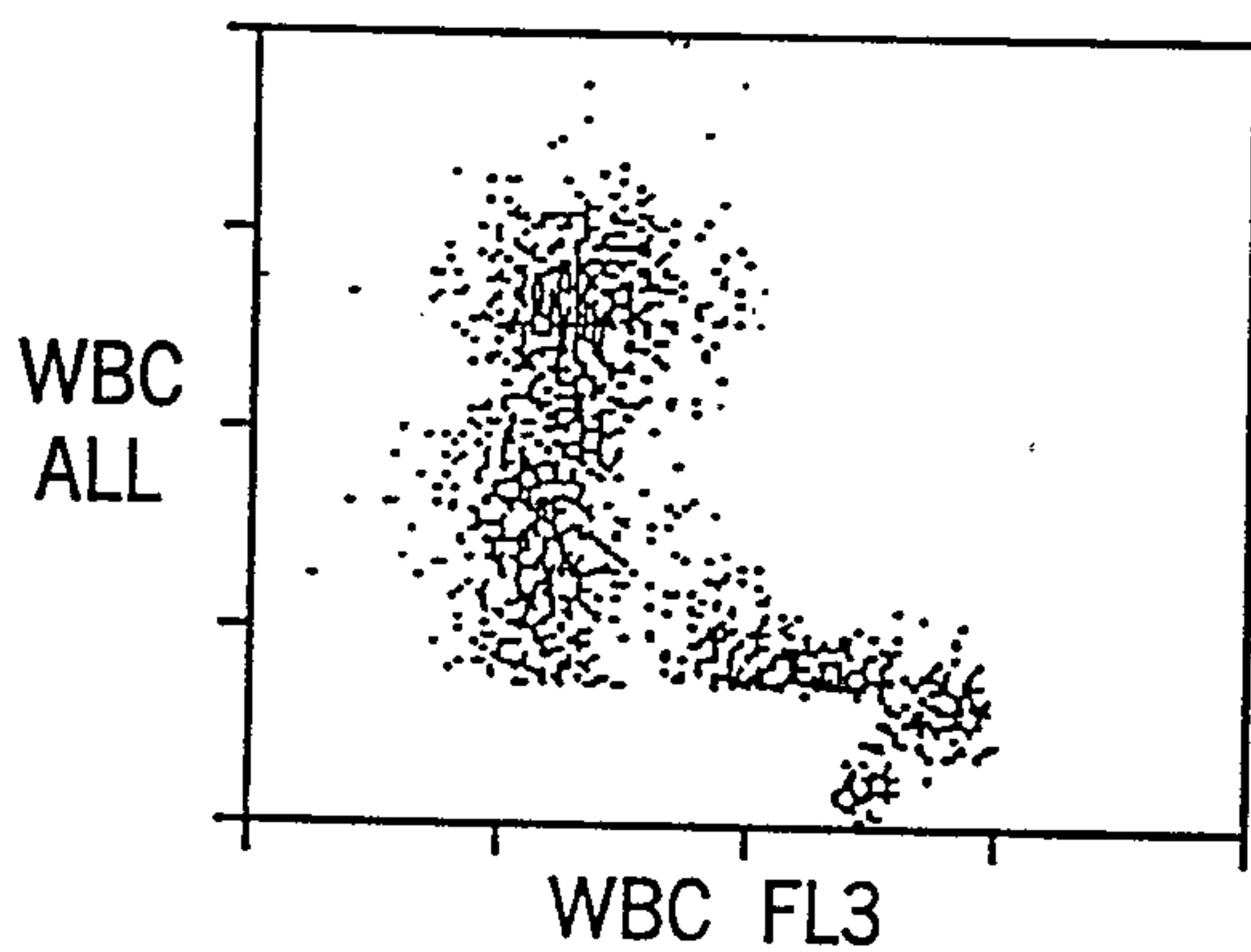

FIG. 14A

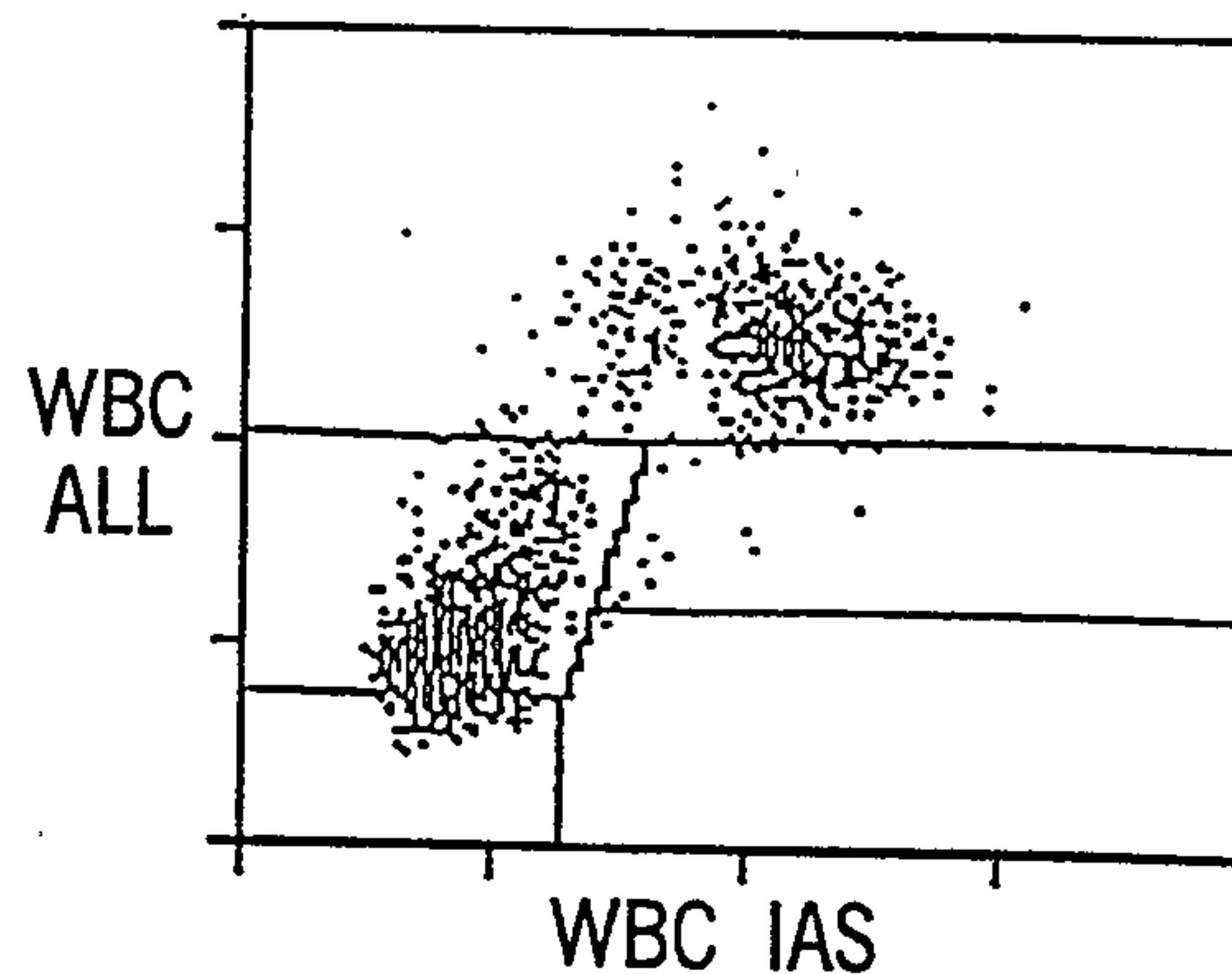

FIG. 14B

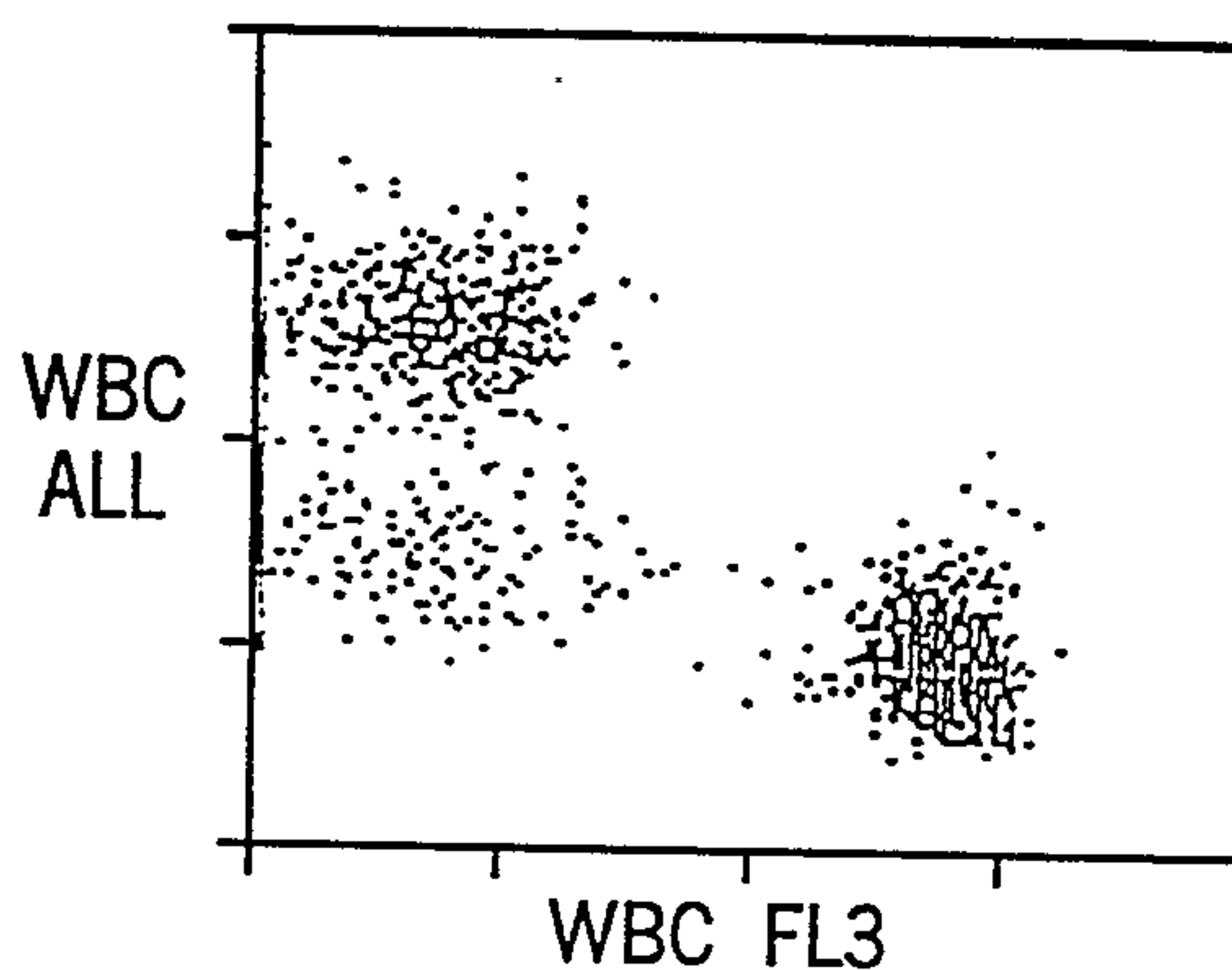
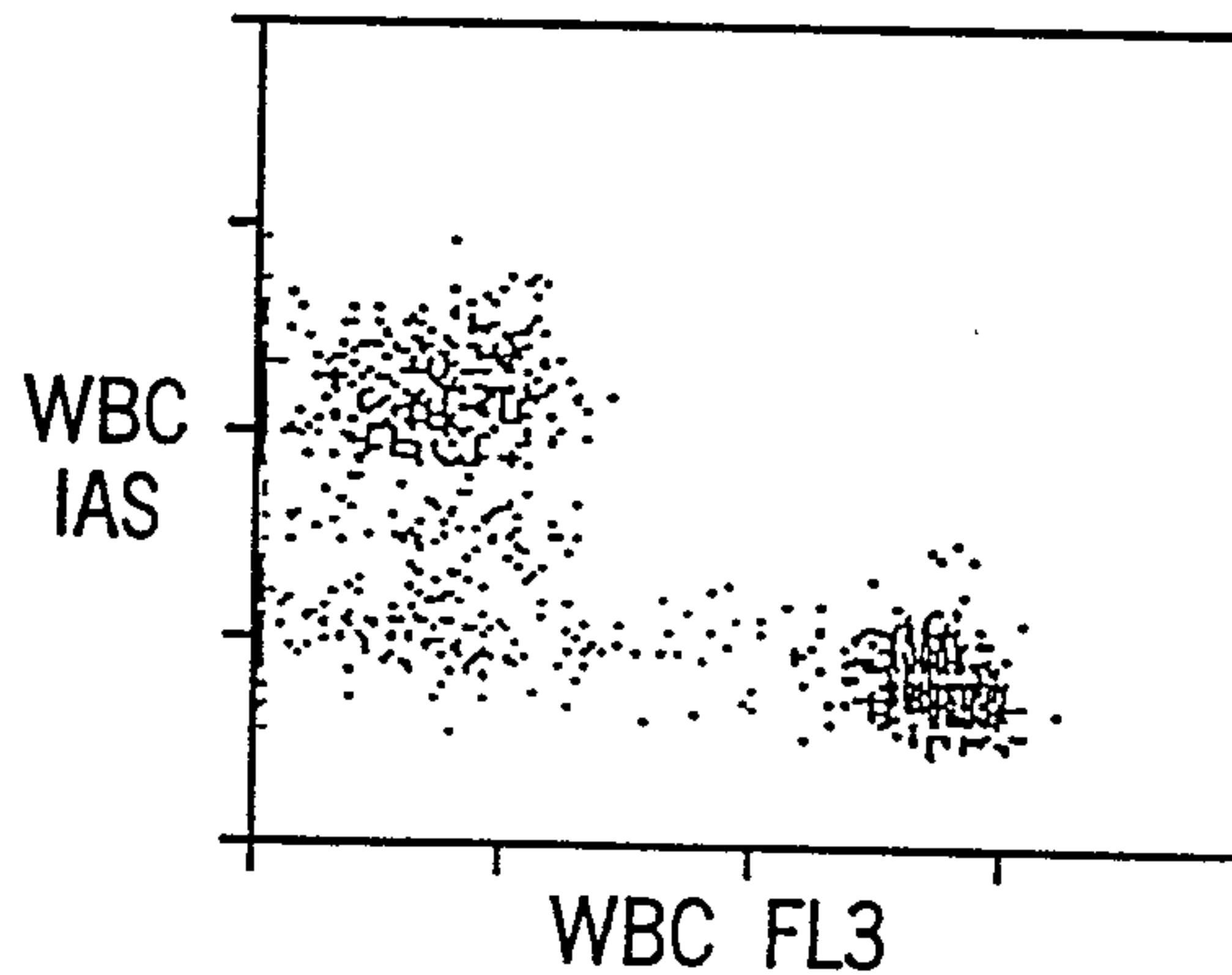

FIG. 14C



9 / 10

FIG. 15A

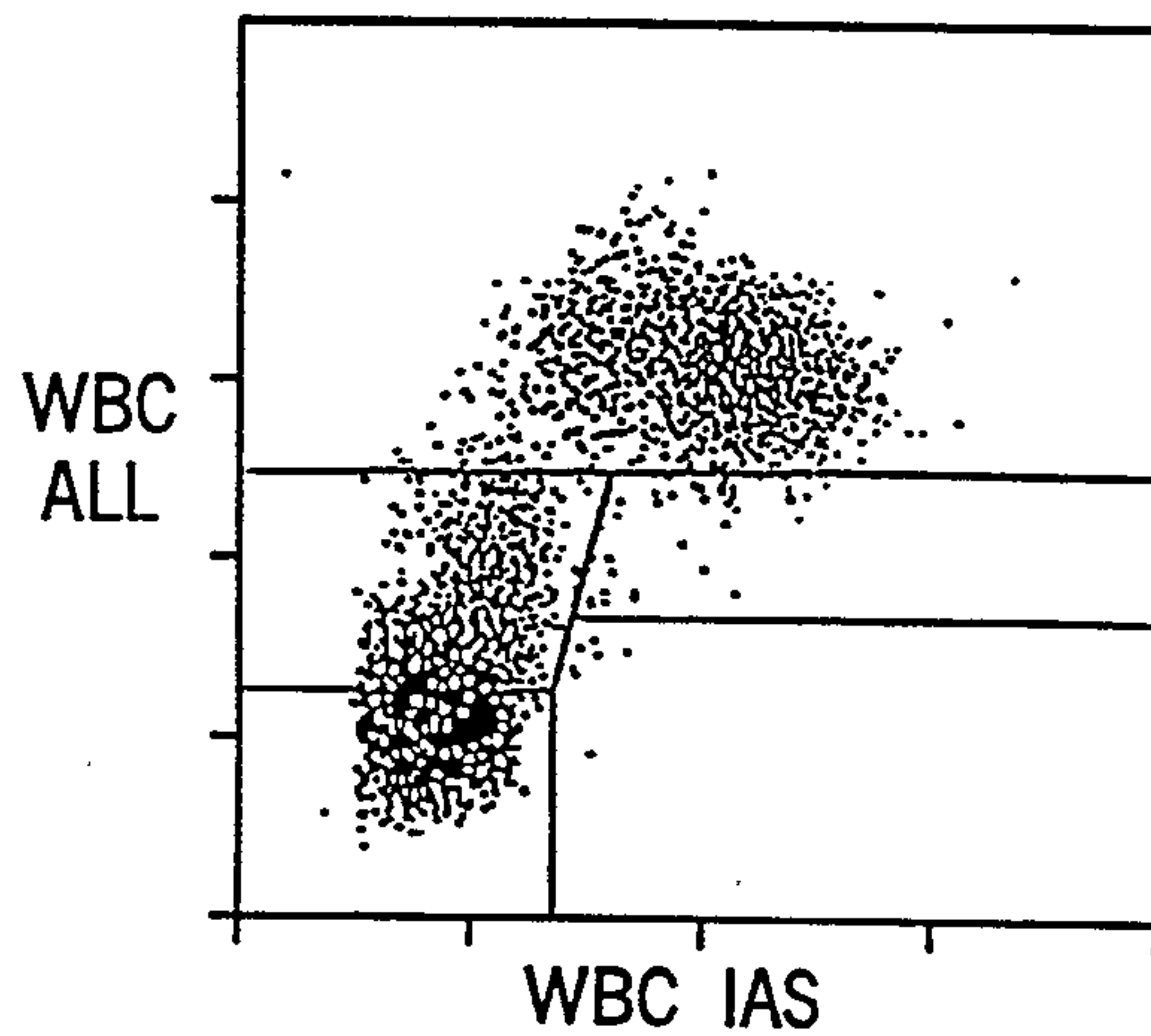

FIG. 15B

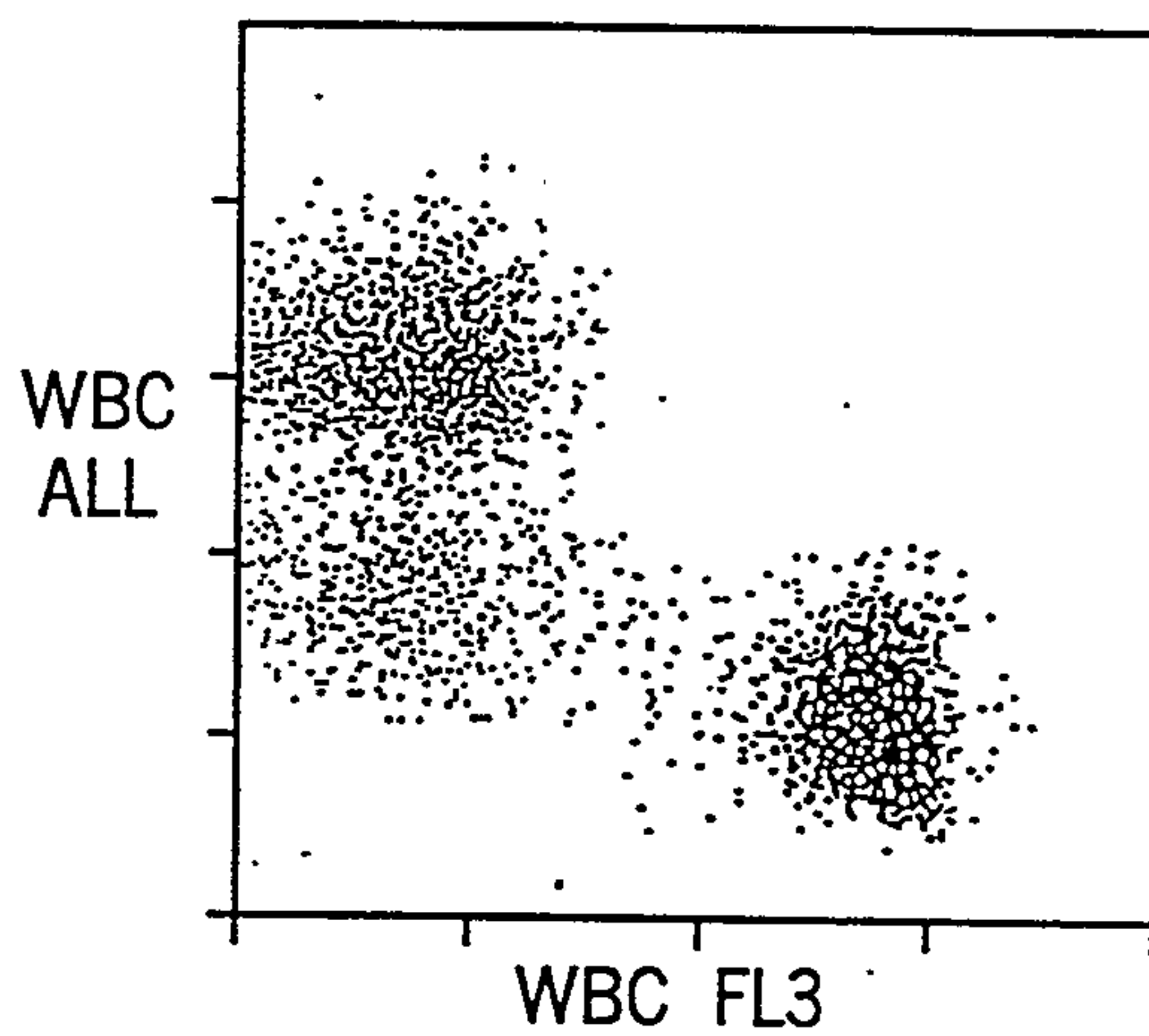

FIG. 16A

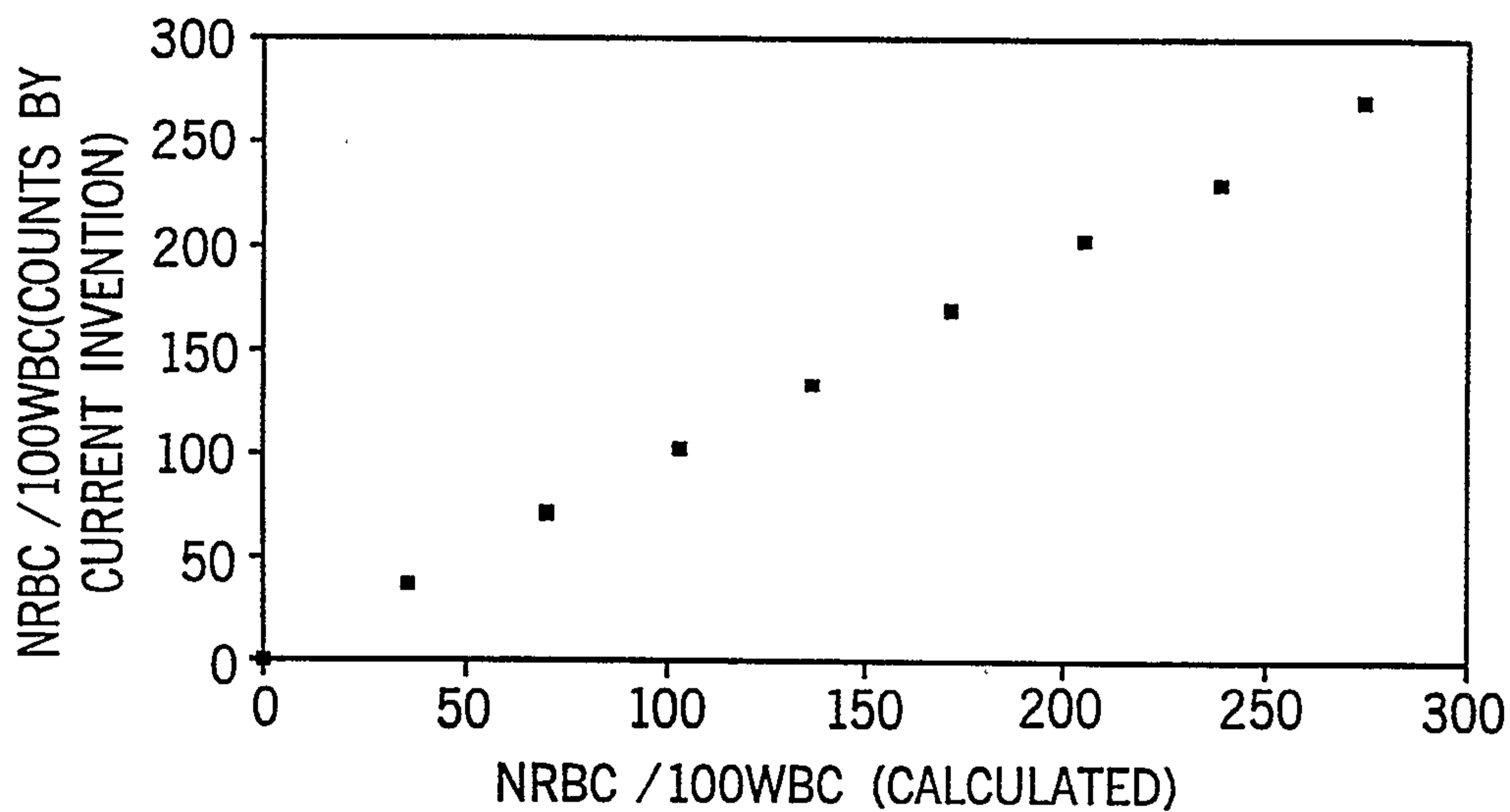

FIG. 16B

