

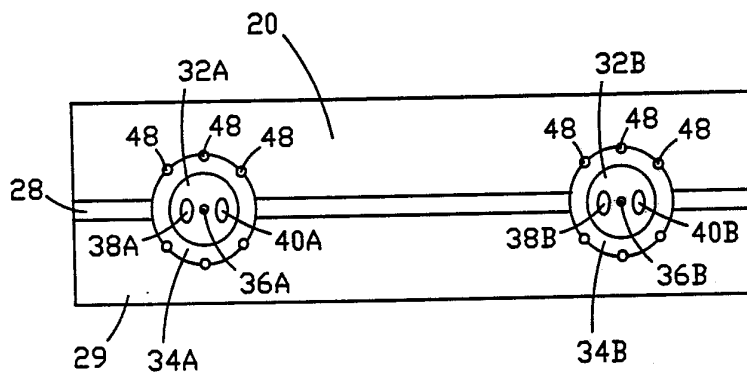

INTERNATIONAL APPLICATION PUBLISHED UNDER THE PATENT COOPERATION TREATY (PCT)

(51) International Patent Classification ⁵ : G02B 6/42	A1	(11) International Publication Number: WO 90/09606 (43) International Publication Date: 23 August 1990 (23.08.90)
<p>(21) International Application Number: PCT/US89/03069</p> <p>(22) International Filing Date: 14 July 1989 (14.07.89)</p> <p>(30) Priority data: 310,336 13 February 1989 (13.02.89) US</p> <p>(71) Applicant: LITTON SYSTEMS, INC. [US/US]; 360 North Crescent Drive, Beverly Hills, CA 89210 (US).</p> <p>(72) Inventor: PAVLATH, George, A. ; 3513 Calle Quebracho, Thousand Oaks, CA 91364 (US).</p> <p>(74) Agent: BROWN, Roy, L.; Litton Industries, 1301 Harbor Bay Parkway, P.O. Box 4004, Alameda, CA 94501-0404 (US).</p>		<p>(81) Designated States: AT (European patent), BE (European patent), CH (European patent), DE (European patent), FR (European patent), GB (European patent), IT (European patent), JP, KR, LU (European patent), NL (European patent), SE (European patent).</p> <p>Published <i>With international search report.</i> <i>With amended claims.</i></p>

(54) Title: METHODS FOR RUGGED ATTACHMENT OF FIBERS TO INTEGRATED OPTICS CHIPS AND PRODUCT THEREOF



(57) Abstract

Methods are disclosed for providing a rugged attachment of an optical fiber to an integrated optics chip. A first plate is attached to a first surface of the chip, the thickness of the chip is reduced to a value less than the diameter of the fiber but of sufficient optical thickness so that the evanescent field of a guided mode is negligible outside the chip, a second plate is attached to a second major surface of the reduced-thickness chip, the fiber is coaxially jacketed with a material suitable for attachment to the first and second plates, the fiber is positioned with respect to a waveguide on the chip, and the jacket of the fiber at its end face is symmetrically attached to both the first and second plates at a plurality of locations. Alternatively, a single plate can be attached to the first surface of the chip without reducing the thickness of the chip and either a jacket on the fiber or the curved periphery of the fiber itself can be attached symmetrically to both the plate and the substrate. The resulting connection between the optical fiber and the integrated optics chip is rugged, thermally insensitive, and suited for batch production processes. A wafer comprising a plurality of chips can be sandwiched between first and second plates or reinforced with a single plate, and subsequently subdivided into individual chips to which optical fibers can then be attached.

FOR THE PURPOSES OF INFORMATION ONLY

Codes used to identify States party to the PCT on the front pages of pamphlets publishing international applications under the PCT.

AT	Austria	ES	Spain	MG	Madagascar
AU	Australia	FI	Finland	ML	Mali
BB	Barbados	FR	France	MR	Mauritania
BE	Belgium	GA	Gabon	MW	Malawi
BF	Burkina Fasso	GB	United Kingdom	NL	Netherlands
BG	Bulgaria	HU	Hungary	NO	Norway
BJ	Benin	IT	Italy	RO	Romania
BR	Brazil	JP	Japan	SD	Sudan
CA	Canada	KP	Democratic People's Republic of Korea	SE	Sweden
CF	Central African Republic	KR	Republic of Korea	SN	Senegal
CG	Congo	LI	Liechtenstein	SU	Soviet Union
CH	Switzerland	LK	Sri Lanka	TD	Chad
CM	Cameroon	LU	Luxembourg	TG	Togo
DE	Germany, Federal Republic of	MC	Monaco	US	United States of America
DK	Denmark				

METHODS FOR RUGGED ATTACHMENT OF FIBERS TO
INTEGRATED OPTICS CHIPS AND PRODUCT THEREOF

BACKGROUND OF THE INVENTION

5

1. Field of the Invention

The invention relates generally to fiberoptic devices and techniques and, more particularly, to methods for attaching fibers to integrated optics chips and the devices resulting from such methods.

10

2. Description of the Related Art

Short lengths of optical fibers called "pigtailed" are bonded to integrated optics chips to aid in coupling to devices on the chips. Once installed, a pigtail allows fiber-to-fiber splicing to be carried out.

15

Previous methods for attaching optical fibers to integrated optics chips involve the use of epoxy adhesives or metal-to-metal welding. An example of the latter is the method disclosed in U.S. Patent Application Serial No. 006,164, entitled "Microattachment of Optical Fibers," filed January 23, 1987, and assigned to the assignee of the present invention, which application is hereby incorporated by reference herein.

20

Epoxy bonds tend to be limited by the characteristics of the epoxy (for example, by changes in light-transmitting and mechanical properties in the desired operating temperature range), are slow to set up, and are difficult to use in an automated production environment. Past methods of metal-to-metal welding have involved structurally asymmetric attachment arrangements which result in undesirably high thermal sensitivities of the optical splices. In an asymmetric attachment, the disparity in coefficients of thermal expansion between adjacent dissimilar materials results in thermally--induced stresses on the fiber. It would

30

35

be a great advance in the art of attaching optical fibers to integrated optics chips if a method could be found which is suited for batch processing and provides a joint which is symmetric and thermally insensitive.

5

SUMMARY OF THE INVENTION

A method for providing a rugged attachment of an optical fiber to an integrated optics chip comprises attaching a first plate to a first major surface of the chip substrate on which the optical circuits reside, removing material from a second major surface of the chip to leave a chip thickness smaller than the diameter of the fiber to be attached to the chip but of sufficient optical thickness so that the evanescent field of a guided mode has a negligibly small value outside the chip, attaching a second plate to a second major surface of the reduced-thickness chip, coaxially jacketing an end portion of the fiber with a material suited for attachment to the first and second plates, positioning an end face of the fiber with respect to the chip so that the fiber is properly optically coupled to a desired portion of an end face of the chip, and attaching the jacket of the fiber end face symmetrically to both the first and second plates at a plurality of locations.

25

Alternatively, a single plate can be attached to the first major surface of the chip without reducing the thickness of the chip, and the jacket of the fiber end face can be attached symmetrically to both the plate and the chip substrate at a plurality of locations. In this embodiment the material of the plate must be the same as the material of the chip substrate. In a variation on this alternative embodiment, the single plate and the chip substrate comprise materials which are suitable for attachment to the curved periphery of an unjacketed

30

fiber, so that the fiber itself can be symmetrically attached to the plate and the substrate at a plurality of locations.

5 The resulting connection between the optical fiber and the integrated optics chip is rugged, thermally insensitive, and suited for batch production processes. In particular, a wafer comprising a plurality of chips can be sandwiched between first and second plates or reinforced with a single top plate, and subsequently
10 subdivided into individual chips to which optical fibers are then attached by the method disclosed.

Techniques of attaching the sandwiching plates or reinforcing plate include using an adhesive, anodic bonding, and laser welding. Jacketing of the optical
15 fiber can be accomplished either by sliding an end of the fiber into a coaxial sleeve of the jacketing material or by coating an end portion of the fiber with a coaxial layer of the material. Suitable coating procedures include electroplating, electroless
20 deposition, vapor deposition, and the application of the coating material in liquid form.

In the embodiment in which the integrated optics chip is reduced in thickness, removal of material from the chip can be done by polishing. Monitoring of the
25 thickness of the chip during the polishing process can be effected in a variety of ways including electro-acoustic techniques.

BRIEF DESCRIPTION OF THE DRAWINGS

The various features and advantages of the present
30 invention will become apparent from the following detailed description taken together with the accompanying drawings, in which:

Fig. 1 is a top plan view of an integrated optics chip which is to be pigtailed; the chip contains a Y
35 circuit typically used in fiberoptic gyroscopes;

Fig. 2 is an end elevational view of the chip of

Fig. 1;

Fig. 3 is an end elevational view of an integrated optics chip with a first plate attached in accordance with the invention using an epoxy adhesive;

5 Fig. 4 is an end elevational view of an integrated optics chip with a first plate attached according to the invention using an anodic bonding technique;

10 Fig. 5 is an end elevational view of a chip with plate attached after polishing of the chip to remove material;

Fig. 6 is an end elevational view of an integrated optics chip with a second plate attached to the chip after its thickness has been reduced;

15 Fig. 7 is an end elevational view of an optical fiber jacketed according to the present invention;

Fig. 8 is a side elevational view, in section, of an optical fiber end being inserted into a sleeve of jacketing material;

20 Fig. 9 is a side elevational view of a jacketed optical fiber attached to an end face of a sandwiched integrated optics chip according to the present invention;

Fig. 10 is a sectional view as indicated in Fig. 9;

25 Fig. 11 is a side elevational view of a jacketed optical fiber attached to a reinforced integrated optics chip according to the present invention;

Fig. 12 is a sectional view as indicated in Fig. 11;

30 Fig. 13 is an end elevational view of a sandwiched integrated optics wafer; and

Fig. 14 is an end elevational view of a reinforced integrated optics wafer.

DESCRIPTION OF THE PREFERRED EMBODIMENTS

Fig. 1 shows a top plan view of an integrated optics (IO) chip 2, which is to be pigtailed, comprising an optical Y circuit 4 on a substrate. The Y optical circuit 4 is of a type typically used in fiberoptic gyroscopes. The standard circuit has an acoustic transducer 6 placed in an unused portion of the chip 2. Transducer 6 consists of an electrode pattern which is designed to launch acoustic waves into the substrate of chip 2 over a broad bandwidth (a few hundred MHz to 1 GHz). Such an electrode pattern is deposited via conventional photolithographic and vacuum deposition techniques on the substrate of the chip. The spacing 8 between the branches of Y circuit 4 at an end face 11 of chip 2 is typically on the order of 200 to 400 micrometers.

Fig. 2 shows an end elevational view of IO chip 2 as seen from the right in Fig. 1. Optical waveguide end faces 12 and 14 are the terminations of the two branches of Y circuit 4 at the end face 11 of chip 2. In these figures the center-to-center distance 8 can be about 350 micrometers, the height 16 of chip 2 can be about 1 mm, and the width 18 of chip 2 can be about 3 mm.

The first step in a method for providing rugged attachment of an optical fiber to integrated optics chip 2 is to attach a suitable glass, ceramic, or metal plate 20 to the top surface of chip 2 as shown in Fig. 3, substantially flush with end face 11. Various bonding techniques which include the use of epoxy glues and anodic techniques can be employed. The use of an epoxy adhesive to bond plate 20 to the top surface of chip 2 is illustrated in Fig. 3, where reference numeral 22 represents a thin layer of adhesive between plate 20 and chip 2. Fig. 4 illustrates the use of an anodic bonding technique to join plate 20 with chip 2. In anodic

bonding, a suitable dielectric buffer layer 24 is deposited on the top surface of chip 2. Dielectric film 24 is typically about 5,000 angstroms thick. A metal plate can then be bonded to dielectric film 24 by
5 applying pressure between the plate and the film and simultaneously applying an electric field to produce migration of metal atoms into the film.

The next step in the process of the invention is to reduce the thickness of chip 2 by removing material from
10 bottom surface 26. One method for doing this would be to polish bottom surface 26. The resulting thickness should be less than a fiber diameter but should be of sufficient optical thickness to contain the guided mode with negligible "leakage" from the waveguide. In other
15 words, the evanescent field of the guided mode should have negligible strength outside the bottom surface 26 of chip 2, where "negligible" means that the light loss can be tolerated in a particular application.

Fig. 5 shows an end elevational view of a
20 plate-chip combination with reduced-thickness chip 28 having a final thickness of about 10 micrometers. The thickness of reduced-thickness chip 28 can be measured by determining the acoustic resonance frequencies of the transducer deposited in the beginning of the process or
25 by several other techniques.

Next, as shown in Fig. 6, a second metal, glass, or ceramic plate 29 similar in dimensions to first plate 20 in dimensions is attached to the bottom surface of reduced-thickness IO chip 28 using the same technique as
30 was used to attach first plate 20. The resulting sandwiched chip 30 is then ready for attachment of an optical fiber.

Before attachment to sandwiched chip 30, an optical fiber 32 is prepared as follows. As shown in Fig. 7,
35 which is an end view of a fiber prepared for chip attachment, the outer surface of fiber 32 must be coated

with a material that is capable of being laser welded, E-beam welded, or otherwise attached to plates 20 and 29 which form a sandwich of reduced-thickness chip 28. The metal, glass, or ceramic jacket 34 can be formed on fiber 32 in a variety of ways. Jacket 34 may be flush with the end of fiber 32 or it may protrude beyond the end in a clip-like structure. The fiber shown in Fig. 7 is a particular type of polarization maintaining (PM) fiber (Corning PRSM (for "polarization retaining single-mode")) but any type of fiber can be used in general with this technique. Fiber core 36 and stress members 38 and 40 are contained in cladding 42 of fiber 32.

In the case of a metal jacket, a jacket coating 34 can be applied by a vapor transport process (such as by evaporation), by electroplating, by an electroless process, or by fitting a coaxial sleeve of the metal over the fiber. A coaxial sleeve arrangement also works well with other materials such as glasses, plastics, or ceramics. Fig. 8 is a side view, in section, of an optical fiber end being inserted into a sleeve of jacketing material.

As shown in the side view of Fig. 9, a jacketed fiber end face is next positioned adjacent a narrow end face of sandwiched chip 30 so that light from a waveguide 12 can properly transmit light to or receive light from fiber core 36. The end of jacket 34 on fiber 32 is then joined (for example, by welding) to the narrow end faces 44 and 46 of top plate 20 and bottom plate 29, respectively. The welding is done symmetrically with respect to a plane through the center of fiber 32 parallel to either surface of chip 28. One possible symmetric pattern of welds is shown in the sectional view of Fig. 10. The plurality of symmetrical welds 48 comprise a rugged attachment of fiber 32 to chip 28 which will not result in thermal stresses on

either fiber 32 or chip 28 when the ambient temperature changes.

The technique described above is well suited to attaching fibers to single-crystal integrated optics chips such as those made of lithium niobate (LiNbO_3), gallium arsenide (GaAs), and potassium titanyl phosphate (KTP). An alternative technique in accordance with the invention can be used for attaching a fiber (jacketed or unjacketed) to a glass substrate. In this alternative process the attachment of only a top plate is required, as shown in Fig. 3. The step of polishing the bottom surface of the substrate to remove material is unnecessary, as is attachment of a bottom plate.

Fig. 11 shows a side elevational view of chip substrate 2 reinforced with a top plate 20, and an optical fiber 32 (jacketed or unjacketed) positioned next to substrate 2 and plate 20 in preparation for attachment. In the sectional view of Fig. 12, optical fiber jackets 34a and 34b are shown attached to top plate 20 and substrate 2 by a plurality of welds 48 at symmetrical locations with respect to a plane parallel to the top surface of substrate 2 which passes through the centers of fiber cores 36a and 36b. The fibers 32a and 32b in this alternative technique need not be jacketed if their curved surfaces are made of a material which can be directly attached to top plate 20 and chip substrate 2.

The methods described above produce stable, thermally rugged, and symmetric attachments between IO chips and coated or uncoated optical fibers.

Fibers and waveguides can be of any type including rib waveguides. For a rib waveguide or an electroded chip, a layer is placed on the top surface of the chip, and perhaps polished, to assure a flat surface for attachment of a top plate.

The processes of the invention can be carried out on chips and on wafers. A wafer comprising a plurality of integrated optics chips can be attached to a top plate, reduced in thickness, and then attached to a bottom plate as described above. The sandwiched, reduced-thickness wafer can subsequently be cut into individual IO chips for attachment of optical fibers in the manner described above.

Fig. 13 is a side elevational view of a sandwiched wafer 50 before subdivision into individual chips. Similarly, a wafer comprising a plurality of IO chips on a glass substrate can be attached to a single top plate without being reduced in thickness, as shown in Fig. 14. The resulting reinforced wafer 52 can then be cut into a plurality of individual IO chips to which optical fibers can be attached by the methods described above. These wafer methods are well suited for fabrication on a production basis.

The rugged optical fiber attachments and thermally insensitive connections produced in accordance with the invention are well matched to single-crystal and amorphous IO substrates. The choice of material for the top and bottom plates covers a wide range (glasses, ceramics, and metals), with the bonding technology being chosen for the particular selections of plate and substrate materials. Since the bonding methods can be applied to chips or wafers, fabrication of chip-fiber devices can be done readily at high rates of production. The techniques described above permit rapid attachment of multiple fibers to a single end face of an integrated optics chip. The multiple fibers can be located in close proximity to each other, a feature which is vitally important for fiber optic gyroscope manufacture.

The above-described embodiments of the invention are furnished as illustrative of its principles, and are not intended to define the only embodiments possible in

accordance with our teaching. Rather, the invention is to be considered as encompassing not only the specific embodiments shown, but also any others falling within the scope of the following claims.

WHAT IS CLAIMED IS:

1. A method for attachment of an optical fiber to an integrated optics chip comprising:

5 (a) attaching a first surface of a first plate to a first surface of a substrate of said chip having a light conduit thereon ending at an end face thereof so that an end face of said first plate extends substantially to said end face of said chip;

10 (b) removing material from a second surface of said chip opposite said first surface to leave a thickness of said chip less than a diameter of said fiber;

(c) attaching a first surface of a second plate to said second surface of said chip, an end face of said second plate extending substantially to said end face of said chip;

15 (d) coaxially jacketing at least a portion of said fiber with a material suitable for attachment to both said first and second plates;

20 (e) positioning an end face of said fiber adjacent to said end face of said chip so that said fiber can properly transmit light to and receive light from said conduit; and

25 (f) attaching a jacket resulting from step d) at said end face of said fiber to said end faces of said first and second plates at a plurality of symmetrical locations.

30 2. The method of claim 1 wherein said locations in step (f) are symmetrically disposed with respect to the central plane of said chip, said plane being parallel to said first and second surfaces of said chip.

3. The method of claim 1 wherein said attaching in step (a) is done with an adhesive.

35 4. The method of claim 1 wherein said attaching in step (c) is done using an adhesive.

5. The method of claim 1 wherein said attaching in step (a) is done by anodic bonding.

6. The method of claim 1 wherein said attaching in step (c) is done by anodic bonding.

5 7. The method of claim 1 wherein said removing material from said second surface of said chip in step (b) is done by polishing.

8. The method of claim 1 wherein said jacketing in step (d) comprises sliding an end of said fiber into a coaxial sleeve of said material open at both ends thereof.

9. The method of claim 1 wherein said jacketing in step (d) comprises coating said fiber with a coaxial layer of said material.

15 10. The method of claim 9 wherein said coating is done by an electroplating process.

11. The method of claim 9 wherein said coating is done by an electroless deposition process.

20 12. The method of claim 9 wherein said coating is done by a vapor deposition process.

13. The method of claim 9 wherein said coating is done by applying said material as a liquid.

25 14. The method of claim 1 wherein said jacketing in step (d) leaves a jacket which extends slightly beyond said end face of said fiber.

15. The method of claim 1 wherein said attaching in step (f) is done by electron beam welding.

30 16. The method of claim 1 wherein said material in step (d) is metallic and said attaching in step (f) is done by laser welding.

17. The method of claim 1 wherein said material in step (d) is glass and said attaching in step (f) is done by laser welding.

35 18. The method of claim 1 wherein said thickness in step (b) is monitored electroacoustically.

19. The method of claim 1 wherein said chip comprises a monocrystalline material chosen from the group consisting of lithium niobate (LiNbO_3), gallium arsenide (GaAs), and potassium titanyl phosphate (KTP).

5 20. The method of claim 1 wherein said chip comprises a glass.

21. The method of claim 1 wherein said thickness of said chip following step (b) corresponds to an optical thickness that is sufficient to make the evanescent field of a guided mode negligibly small
10 outside said chip.

22. A method for attachment of at least one optical fiber to an integrated optics chip comprising:

(a) attaching a first surface of a plate to a first
15 surface of a substrate of said chip having a light conduit thereon ending at an end face thereof so that an end face of said plate extends substantially to said end face of said chip, said plate comprising a material the same as that of said substrate;

20 (b) coaxially jacketing at least a portion of said fiber with a second material suitable for attachment to both said plate and said substrate of said chip;

(c) positioning an end face of said fiber adjacent to said end face of said chip so that said fiber can
25 properly transmit light to and receive light from said conduit; and

(d) attaching said jacket at said end face of said fiber to said end faces of said substrate and said plate at a plurality of symmetrical locations.

30 23. The method claim 22 wherein said locations in step (d) are symmetrically disposed with respect to the plane in which said first surface of said chip substantially lies.

35 24. The method of claim 22 wherein said attaching in step (a) is done with an adhesive.

25. The method of claim 22 wherein said attaching in step (a) is done by anodic bonding.

26. The method of claim 22 wherein said substrate comprises a glass and said second material comprises a glass also.

27. The method of claim 22 wherein said attaching in step (d) is done by laser welding.

28. The method of claim 22 wherein said jacketing in step (b) comprises sliding an end of said fiber into a coaxial sleeve of said second material open at both ends thereof so that said end face of said fiber extends substantially to an end of said coaxial sleeve.

29. The method of claim 22 wherein said jacketing in step (b) comprises sliding an end of said fiber into a coaxial sleeve of said second material open at both ends thereof so that said end of said fiber is nearly flush with an end of said sleeve, said sleeve extending beyond said end of said fiber.

30. The method of claim 22 wherein said jacketing in step (b) comprises coating said fiber with said second material.

31. The method of claim 30 wherein said coating comprises applying said second material as a liquid.

32. The method of claim 30 wherein said coating comprises depositing said second material by a vapor transport process.

33. The method of claim 22 wherein step (b) is omitted and in step (d) an unjacketed curved periphery of said end face of said at least one fiber is attached to said plate and said substrate as described.

34. A method for facilitating the attachment of optical fibers to integrated optics chips on a production basis comprising:

(a) starting with a wafer comprising a plurality of integrated optics chips on a first surface of a substrate, attaching a first surface of a first plate to

said first surface of said wafer so that a peripheral edge of said first plate is substantially flush with a peripheral edge of said wafer substrate;

5 (b) removing material from a second surface of said substrate opposite said first surface to leave a thickness of said substrate less than a diameter of one of said optical fibers;

10 (c) attaching a first surface of a second plate to said second surface of said wafer so that said peripheral edge of said substrate is substantially flush with a peripheral edge of said second plate;

(d) subdividing a sandwiched wafer resulting from step (c) into a plurality of individual sandwiched integrated optics chips;

15 (e) coaxially jacketing at least a portion of each of said plurality of fibers with a material suitable for attachment to portions of said first and second plates remaining as part of an individual sandwiched chip;

20 (f) positioning an end face of each said fiber adjacent to an end face of each said sandwiched chip so that said fiber can properly transmit light to and receive light from a light conduit of said sandwiched chip ending at said end face; and

25 (g) attaching each of a plurality of jackets resulting from step (e) at each of said end faces of said plurality of fibers positioned at each of said end faces of said plurality of sandwiched chips to said remaining portions of said first and second plates at a plurality of symmetrical locations.

30 35. The method of claim 34 wherein said locations in step (g) are symmetrically disposed with respect to the central plane of each said sandwiched chip, said plane being parallel to said first and second surfaces of said chip.

35 36. The method of claim 34 wherein said attaching in step (a) comprises using an adhesive.

37. The method of claim 34 wherein said attaching in step (c) comprises using an adhesive.

38. The method of claim 34 wherein said attaching in step (a) comprises anodic bonding.

5 39. The method of claim 34 wherein said attaching in step (c) comprises anodic bonding.

40. The method of claim 34 wherein said removing material from said second major surface of said wafer substrate in step (b) is done by polishing.

10 41. The method of claim 34 wherein said thickness of said chip following step (b) corresponds to an optical thickness that is sufficient to make the evanescent field of a guided mode negligibly small outside said chip.

15 42. A method for facilitating the attachment of optical fibers to integrated optics chips on a production basis comprising:

(a) starting with a wafer comprising a plurality of integrated optics chips on a first surface of a substrate, attaching a first surface of a plate comprising a material the same as that of said substrate of said wafer to said first surface of said wafer so that a peripheral edge of said plate is substantially flush with a peripheral edge of said wafer substrate;

25 (b) subdividing a reinforced wafer resulting from step (a) into a plurality of individual reinforced integrated optics chips;

(c) coaxially jacketing at least a portion of each of said plurality of fibers with a material suitable for attachment to said substrate and to a portion of said plate remaining as part of an individual reinforced chip;

30 (d) positioning an end face of each said fiber adjacent to an end face of each said reinforced chip so that said fiber can properly transmit light to and
35

receive light from a light conduit of said reinforced chip ending at said end face; and

(e) attaching each of a plurality of jackets resulting from step (c) at each of said end faces of said plurality of fibers positioned at each of said end faces of said plurality of reinforced chips to said substrate and said remaining portion of said plate at a plurality of symmetrical locations.

43. The method of claim 42 wherein said locations in step (e) are symmetrically disposed with respect to the central plane of each said reinforced chip, said plane being parallel to said first and second surfaces of said chip.

44. The method of claim 42 wherein said attaching in step (a) comprises using an adhesive.

45. The method of claim 42 wherein said attaching in step (a) comprises anodic bonding.

46. The method of claim 42 wherein said substrate comprises a glass and said second material comprises a glass also.

47. The method of claim 42 wherein said attaching in step (e) comprises laser welding.

48. An optical device comprising:

an integrated optics chip having a substrate with at least one waveguide on a first surface thereof, a first plate with a first surface thereof attached to said first surface of said chip, and a second plate with a first surface thereof attached to a second surface of said chip opposite said first surface thereof, said first and second plates having end faces which extend substantially to each end face of said chip through which light coming from and leaving each said waveguide would exit and enter said chip; and

at least one optical fiber, each said fiber having an end face positioned adjacent said waveguide at one of said end faces of said chip so that said fiber can

properly transmit light to and receive light from said waveguide, said fiber having a coaxial jacket on at least a portion thereof adjacent said fiber end face attached to said first and second plates at a plurality of symmetrical locations.

49. The device of claim 48 wherein said locations are symmetrically disposed with respect to the central plane of said chip, said plane being parallel to said first and second surfaces of said chip.

50. An optical device comprising:

an integrated optics chip having a substrate with at least one waveguide on a first surface thereof, and having a first plate with a first surface thereof attached to said first surface of said chip so that an end face of said first plate extends substantially to an end face of said chip on which said waveguide ends; and

at least one optical fiber, each said fiber having an end face positioned adjacent a location of each said at least one waveguide at one of said end faces of said chip so that said fiber can properly transmit light to and receive light from said waveguide, said fiber having a coaxial jacket on at least a portion thereof adjacent said fiber end face attached to said first plate and to said substrate at a plurality of symmetrical locations.

51. The device of claim 50 wherein said locations are symmetrically disposed with respect to the plane in which said first surface of said chip substantially lies.

52. An optical device comprising:

an integrated optics chip having a substrate with at least one waveguide on a first surface thereof, and having a plate with a first surface thereof attached to said first surface of said chip so that an end face of said plate extends substantially to an end face of said chip on which said waveguide ends; and

at least one optical fiber, each said fiber having an end face positioned adjacent a location of said waveguide in said end face of said chip so that said fiber can properly transmit light to and receive light from said waveguide, said fiber having an outer core of material attached to said plate and to said substrate at a plurality of symmetrical locations.

53. The device of claim 52 wherein said locations are symmetrically disposed with respect to the plane in which said first surface of said chip substantially lies.

54. A sandwiched wafer comprising a plurality of integrated optics chips on a first surface of a substrate, fabricated as an intermediate product before optical fibers are attached to individual chips comprising:

A wafer having a substrate with said first surface of said substrate attached to a first surface of a first plate and a second surface opposite said first surface thereof attached to a first surface of a second plate, said substrate having a thickness less than a diameter of an optical fiber to be attached.

55. The wafer of claim 54 wherein said substrate is of sufficient optical thickness so that the evanescent field of a guided mode is negligibly small outside said chip.

56. A reinforced wafer comprising a plurality of integrated optics chips on a first surface of a substrate, fabricated as an intermediate product before optical fibers are attached to individual chips comprising:

A wafer substrate having said first surface thereof attached to a first surface of a plate, said plate comprising a material the same as that of said substrate.

57. A connection between an optical fiber having a coaxial jacket on at least a portion thereof adjacent an end face and a sandwiched integrated optics chip with first and second plates attached to first and second opposite surfaces thereof comprising:

A plurality of localized junctions between an end of said jacket and first and second end faces of said first and second plates, respectively.

58. The connection of claim 57 wherein said junctions are symmetrically located with respect to the plane in which said first surface of said chip substantially lies.

59. A connection between an optical fiber having a coaxial jacket on at least a portion adjacent an end face thereof and a reinforced integrated optics chip having a substrate with a first surface thereof attached to a first surface of a plate comprising:

A plurality of localized junctions of an end of said jacket with first and second end faces of said substrate and said plate, respectively.

60. The connection of claim 59 wherein said junctions are symmetrically located with respect to the plane in which said first surface of said substrate substantially lies.

61. A connection between an optical fiber and an integrated optics chip having a substrate with a first surface attached to a first surface of a plate comprising:

A plurality of localized junctions of an outer core of material of said fiber at an end thereof with first and second end faces of said plate and said substrate, respectively.

62. The connection of claim 61 wherein said junctions are symmetrically located with respect to the plane in which said first surface of said substrate substantially lies.

AMENDED CLAIMS

[received by the International Bureau
on 20 April 1990 (20.04.90);
original claims 1-4, 19-62 amended; other claims unchanged (14 pages)]

1. A method for attachment of an optical fiber, having a predetermined diameter, to an integrated optics chip having a light conduit thereon ending at an end face thereof, characterized by:

(a) attaching a first surface of a first plate to a first surface of a substrate of said chip so that an end face of said first plate extends substantially to said end face of said chip;

removing material from a second surface of said chip opposite said first surface to leave a thickness of said chip less than said predetermined diameter of said fiber;

(c) attaching a first surface of a second plate to said second surface of said chip, an end face of said second plate extending substantially to said end face of said chip;

(d) coaxially jacketing at least a portion of said fiber with a material suitable for attachment to both said first and second plates;

(e) positioning an end face of said fiber adjacent to said end face of said chip so that said fiber can properly transmit light to and receive light from said conduit; and

(f) attaching a jacket resulting from step d) at said end face of said fiber to said end faces of said first and second plates at a plurality of symmetrical locations.

2. The method of claim 1 wherein said locations in step (f) are symmetrically disposed with respect to the central plane of said chip, said plane being parallel to said first and second surfaces of said chip.

3. The method of claim 1 wherein said attaching in step (a) is done using an adhesive.

4. The method of claim 1 wherein said attaching in step (c) is done using an adhesive.

19. The method of claim 1 wherein said chip comprises a monocrystalline material chosen from the group consisting of lithium niobate (LiNbO_3) gallium arsenide (GaAs), and potassium titanuyl phosphate (KTP).

20. The method of claim 1 wherein said chip comprises a glass.

21. The method of claim 1 wherein said thickness of said chip following step (b) corresponds to an optical thickness that is sufficient to make the evanescent field of a guided mode negligibly small outside said chip.

22. A method for attachment of an integrated optics chip which has a light conduit thereon ending at an end face thereof to at least one optical fiber, characterised by:

(a) attaching a first surface of a plate to a first surface of a substrate of said chip so that an end face of said plate extends substantially to said end face of said chip, said plate comprising a material the same as that of said substrate;

(b) coaxially jacketing at least a portion of said fiber with a second material suitable for attachment to both said plate and said substrate of said chip;

(c) positioning an end face of said fiber adjacent to said end face of said chip so that said fiber can properly transmit light to and receive light from said conduit; and

(d) attaching said jacket at said end face of said fiber to said end faces of said substrate and said plate at a plurality of symmetrical locations.

23. The method of claim 22 wherein said locations in step (d) are symmetrically disposed with respect to the plane in which said first surface of said chip substantially lies.

24. The method of claim 22 wherein said attaching in step (a) is done with an adhesive.

25. The method of claim 22 wherein said attaching in step (a) is done by anodic bonding.

26. The method of claim 22 wherein said substrate comprises a glass and said second material comprises a glass also.

27. The method of claim 22 wherein said attaching in step (d) is done by laser welding.

28. The method of claim 22 wherein said jacketing in step (b) comprises sliding an end of said fiber into a coaxial sleeve of said second material open at both ends thereof so that said end face of said fiber extends beyond said end of said fiber.

29. The method of claim 22 wherein said jacketing in step (b) comprises sliding an end of said fiber into a coaxial sleeve of said second material open at both ends thereof so that said end of said fiber is nearly flush with an end of said sleeve, said sleeve extending beyond said end of said fiber.

30. The method of claim 22 wherein said jacketing in step (b) comprises coating said fiber with said second material.

31. The method of claim 30 wherein said coating comprises applying said second material as a liquid.

32. The method of claim 30 wherein said coating comprises depositing said second material by a vapor transport process.

33. The method of claim 22 wherein step (b) is omitted and in step (d) anunjacketed curved periphery of said end face of said at least one fiber is attached to said plate and said substrate as described.

34. A method of attaching a plurality of integrated optics chips, initially on a first surface of a substrate of a wafer to a plurality of optical

fibers having predetermined diameters, characterised by:

(a) attaching a first surface of a first plate to said first surface of said wafer so that a peripheral edge of said first plate is substantially flush with a peripheral edge of said wafer substrate;

(b) removing material from a second surface of said substrate opposite said first surface to leave a thickness of said substrate less than a predetermined diameter of one of said optical fibers;

(c) attaching a first surface of a second plate to said second surface of said wafer so that said peripheral edge of said substrate is substantially flush with a peripheral edge of said second plate;

(d) subdividing a sandwiched wafer resulting from step (c) into a plurality of individual sandwiched integrated optics chips;

(e) coaxially jacketing at least a portion of each of said plurality of fibers with a material suitable for attachment to portions of said first and second plates remaining as part of an individual sandwiched chip;

(f) positioning an end face of each said fiber adjacent to an end face of each said sandwiched chip so that said fiber can properly transmit light to and receive light from a light conduit of said sandwiched chip ending at said end face; and

(g) attaching each of a plurality of jackets resulting from step (e) at each of said end faces of said plurality of fibers positioned at each of said end faces of said plurality of sandwiched chips to said remaining portions of said first and second plates at a plurality of symmetrical locations.

35. The method of claim 34 wherein said locations in step (g) are symmetrically disposed with respect to the central plane of each said sandwiched chip, said plane being parallel to said first and second surfaces of said chip.

36. The method of claim 34 wherein said attaching in step (a) comprises using an adhesive.

37. The method of claim 34 wherein said attaching in step (c) comprises using an adhesive.

38. The method of claim 34 wherein said attaching in step (a) comprises anodic bonding.

39. The method of claim 34 wherein said attaching in step (c) comprises galvanic bonding.

40. The method of claim 34 wherein said removing material from said second major surface of said wafer substrate in step (b) is done by polishing.

41. The method of claim 34 wherein said thickness of said chip following step (b) corresponds to an optical thickness that is sufficient to make the evanescent field of a guided mode negligibly small outside said chip.

42. A method for facilitating the attachment of a plurality of integrated optics chips on a first surface of a substrate of a wafer to a plurality of optical fibers, characterised by:

(a) attaching a first surface of a plate comprising a material the same as that of said substrate of said wafer to said first surface so that a peripheral edge of said plate is substantially flush with a peripheral edge of said wafer substrate;

(b) subdividing a reinforced wafer resulting from step (a) into a plurality of individual reinforced integrated optics chips;

(c) coaxially jacketing at least a portion of each of said plurality of fibers with a material suitable for attachment to said substrate and to a portion of said plate remaining as part of an individual reinforced chip;

(d) positioning an end face of each said fiber adjacent to an end face of each said reinforced chip so that said fiber can properly transmit light to and

receive light from a light conduit of said reinforced chip ending at said end face; and

(e) attaching each of a plurality of jackets resulting from step (c) at each of said end faces of said plurality of fibers positioned at each of said end faces of said plurality of reinforced chips to said substrate and said remaining portion of said plate at a plurality of symmetrical locations.

43. The method of claim 42 wherein said locations in step (e) are symmetrically disposed with respect to the central plane of each said reinforced chip, said plane being parallel to said first and second surfaces of said chip.

44. The method of claim 42 wherein said attaching in step (a) comprises using an adhesive.

45. The method of claim 42 wherein said attaching in step (a) comprises anodic bonding.

46. The method of claim 42 wherein said substrate comprises a glass and said second material comprises a glass also.

47. The method of claim 42 wherein said attaching in step (e) comprises laser welding.

48. An optical device with an integrated optics chip having a substrate with at least one waveguide on a first surface thereof, and at least one optical fiber, characterised by:

a first plate with a first surface thereof attached to said first surface of said chip, and a second plate with a first surface thereof attached to a second face of said chip opposite said first surface thereof, said first and second plates having end faces which extend substantially to each end face of said chip through which light coming from and leaving each said waveguide would exit and enter said chip; and

at least one optical fiber, each said fiber having an end face positioned adjacent said waveguide at one of said end faces of said chip so that said fiber can

properly transmit light from said waveguide, said fiber having a coaxial jacket on at least a portion thereof adjacent said fiber end face attached to said first and second plates at a plurality of symmetrical locations.

49. The device of claim 48 wherein said locations are symmetrically disposed with respect to the central plane of said chip, said plane being parallel to said first and second surfaces of said chip.

50. An optical device including an integrated optics chip having a substrate with at least one waveguide on a first surface thereof, and at least one optical fiber, characterised by:

a first plate with a first surface thereof attached to said first surface of said chip so that an end face of said first plate extends substantially to an end face of said chip on which said waveguide ends; and

each said fiber having an end face positioned adjacent a location of each said at least one waveguide at one of said end faces of said chip so that said fiber can properly transmit light to and receive light from said waveguide, said fiber having a coaxial jacket on at least a portion thereof adjacent said fiber end face attached to said first plate and to said substrate at a plurality of symmetrical locations.

51. The device of claim 50 wherein said locations are symmetrically disposed with respect to the plane in which said first surface of said chip substantially lies.

52. An optical device including an integrated optics chip having a substrate with at least one waveguide on a first surface thereof, and at least one optical fiber, characterised by:

a plate with a first surface thereof attached to said first surface of said chip so that an end face of said plate extends substantially to an end face of said chip on which said waveguide ends; and

each said fiber has an end face positioned adjacent a location of said waveguide in said end face of said chip so that said fiber can properly transmit light to and receive light from said waveguide, said fiber having an outer core of material attached to said plate and to said substrate at a plurality of symmetrical locations.

53. The device of claim 52 wherein said locations are symmetrically disposed with respect to the plane in which said first surface of said chip substantially lies.

54. A sandwiched wafer having a plurality of integrated optics chips on a first surface of a substrate; and first and second plates, characterised by:

a first surface of said substrate being attached to a first surface of said first plate, and a second surface opposite said first surface thereof attached to a first surface of a second plate, said substrate having a predetermined thickness less than a diameter of an optical fiber to be attached.

55. The wafer of claim 54 wherein said substrate is of sufficient optical thickness so that the evanescent field of a guided mode is negligibly small outside said chip.

56. A reinforced wafer having a plurality of integrated optics chips on a first surface of a substrate, characterised by:

said first surface of said substrate being attached to a first surface of a plate, said plate comprising a material the same as that of said substrate.

57. A connection between an optical fiber having a coaxial jacket on at least a portion thereof adjacent an end face and a sandwiched integrated optics chip with first and second plates attached to first and second opposite surfaces thereof, characterised by:

a plurality of localized junctions between an end of said jacket and first and second end faces of said first and second plates, respectively.

58. The connection of claim 57 wherein said junctions are symmetrically located with respect to the plane in which said first surface of said chip substantially lies.

59. A connection between an optical fiber having a coaxial jacket on at least a portion adjacent an end face thereof and a reinforced integrated optics chip having a substrate with a first surface thereof attached to a first surface of a plate, characterised by:

a plurality of localized junctions of an end of said jacket with first and second end faces of said substrate and said plate, respectively.

60. The connection of claim 59 wherein said junctions are symmetrically located with respect to the plane in which said first surface of said substrate substantially lies.

61. A connection between an optical fiber and an integrated optics chip having a substrate with a first surface attached to the first surface of a plate, characterised by:

a plurality of localized junctions of an outer core of material of said fiber at an end thereof with first and second end faces of said plate and said substrate, respectively

62. The connection of claim 61 wherein said junctions are symmetrically located with respect to the plane in which said first surface of said substrate substantially lies.

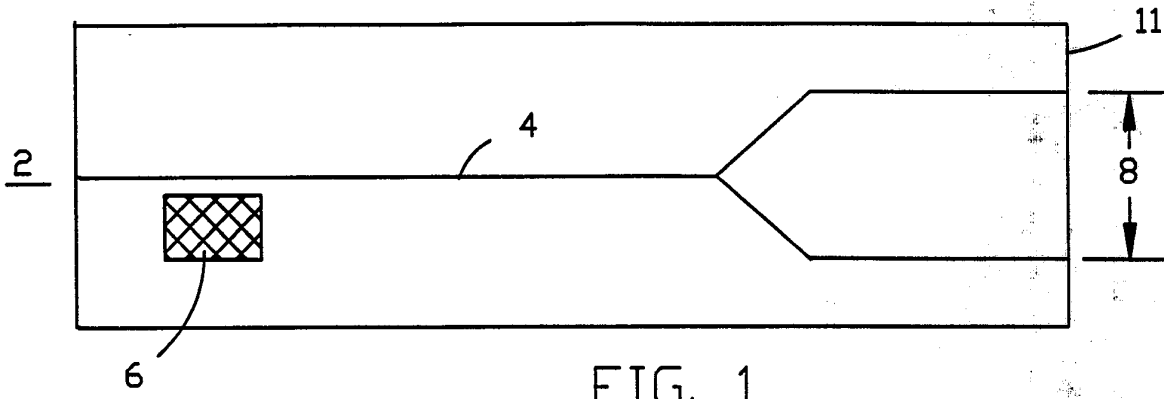

FIG. 1

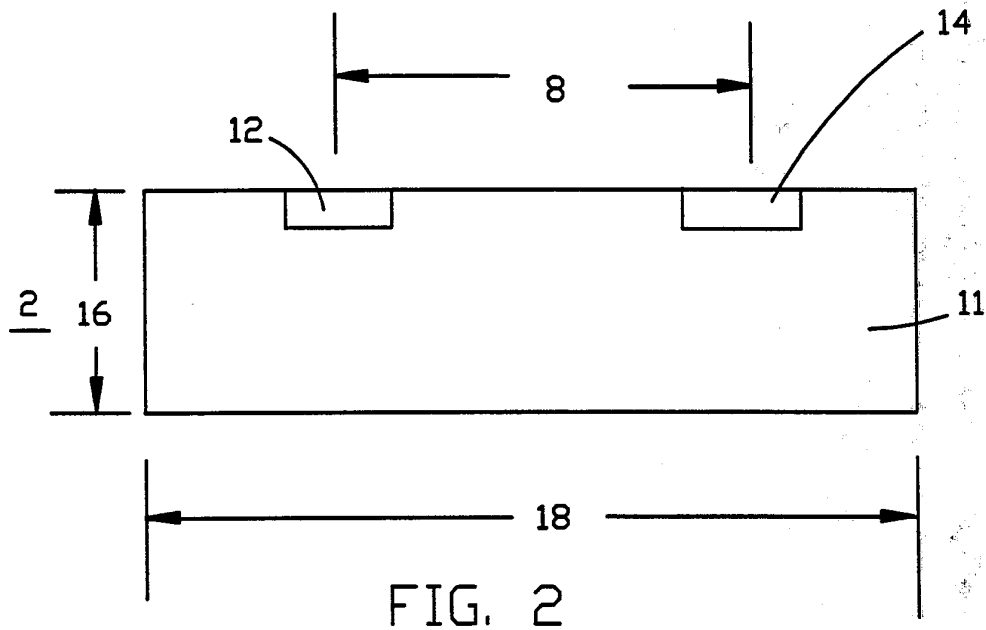

FIG. 2

217

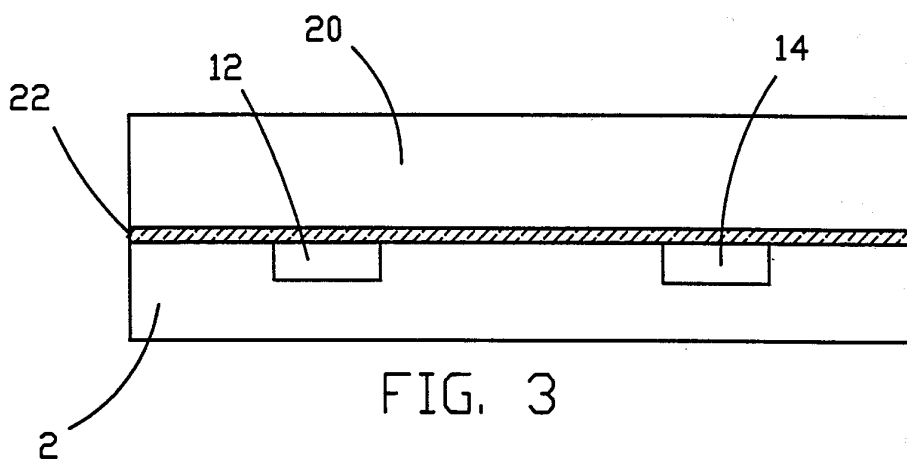

FIG. 3

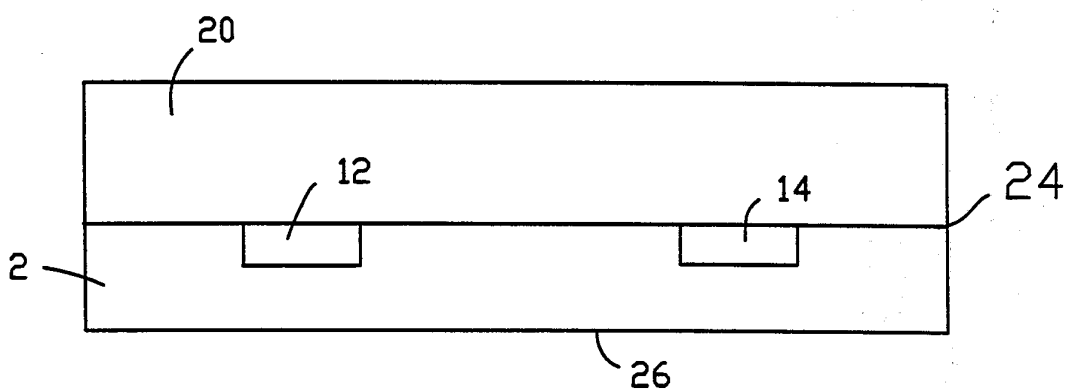

FIG. 4

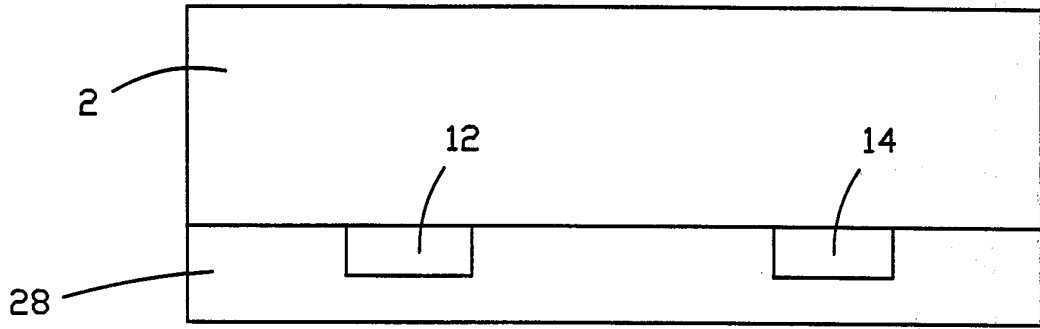

FIG. 5

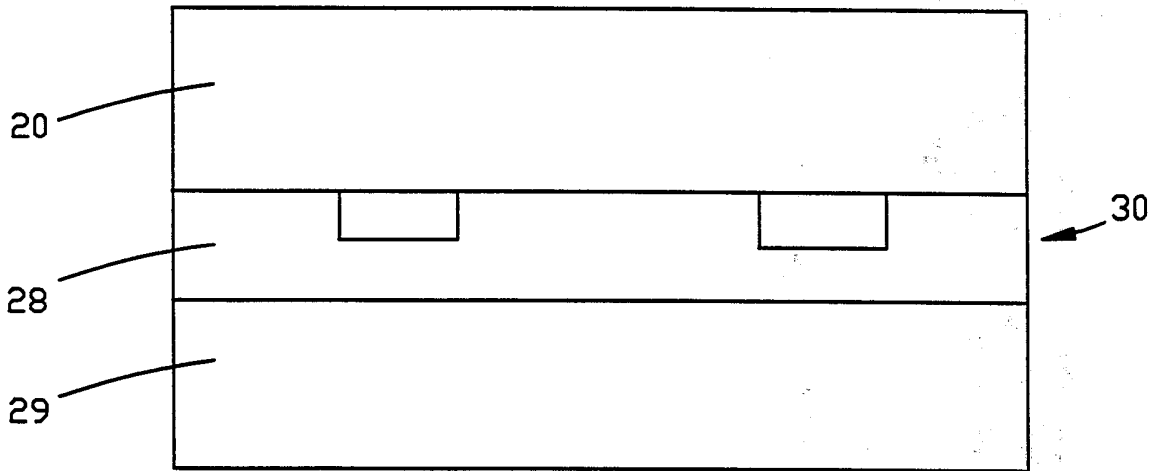

FIG. 6

4/7

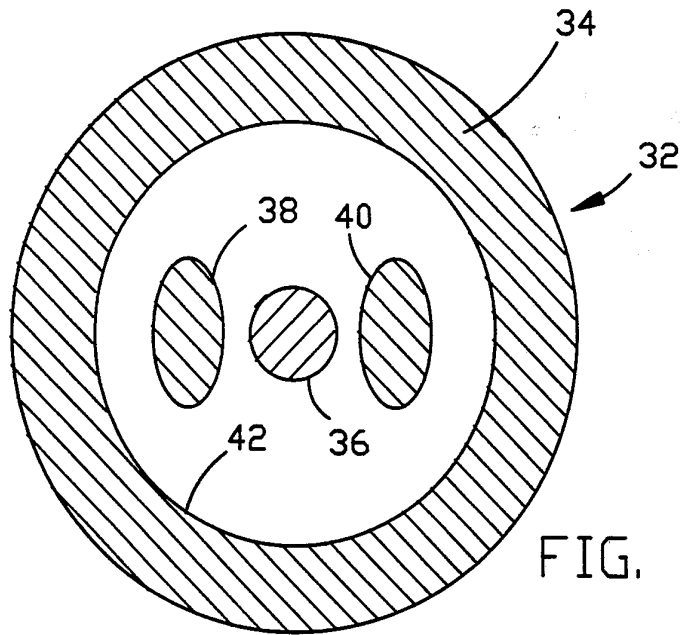

FIG. 7

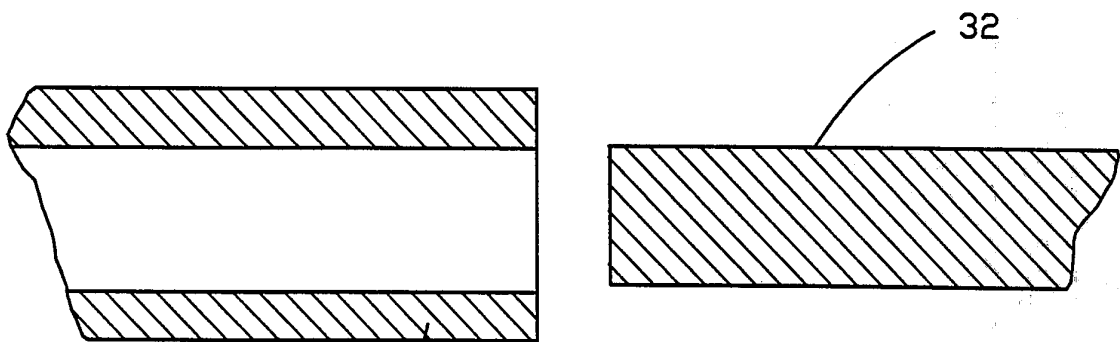
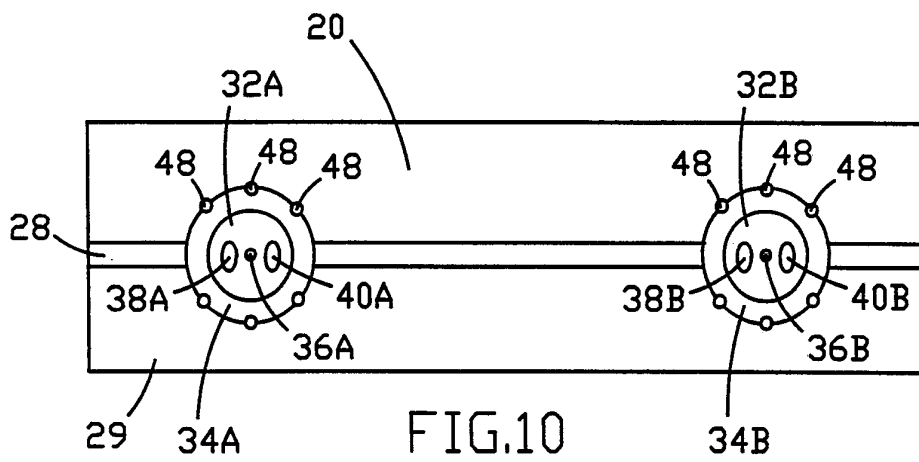
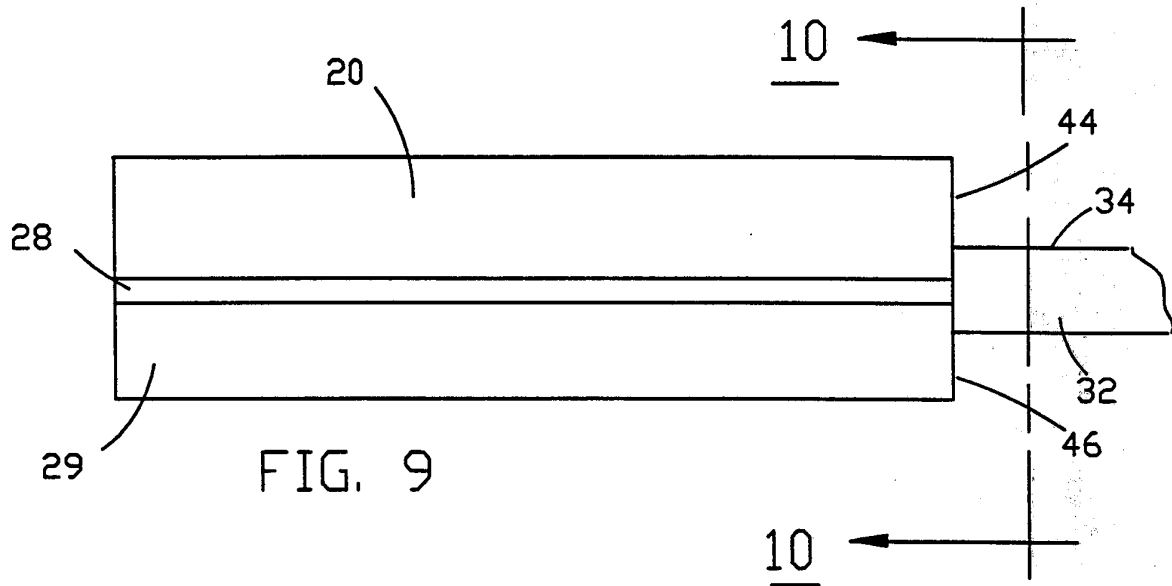

FIG. 8



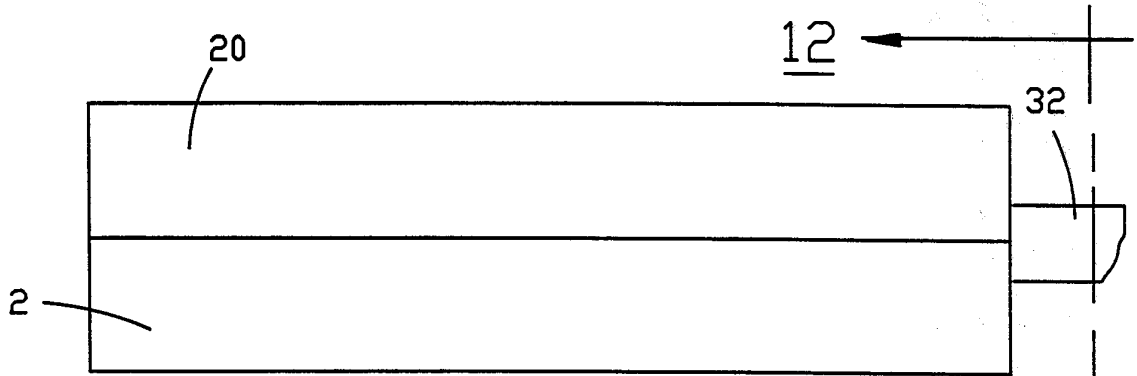

FIG.11

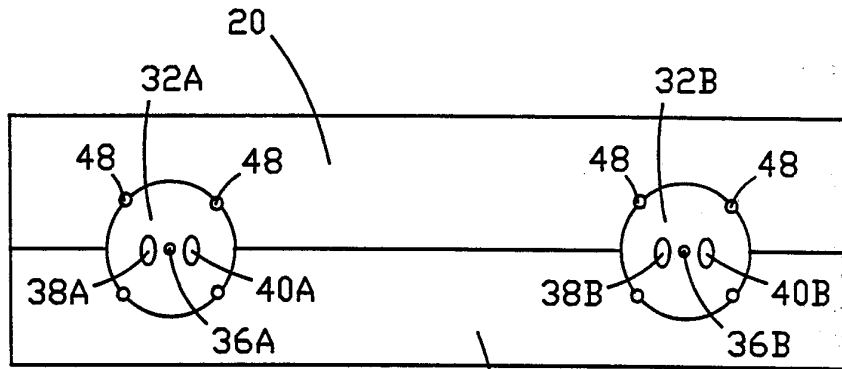

FIG.12

2

7/7

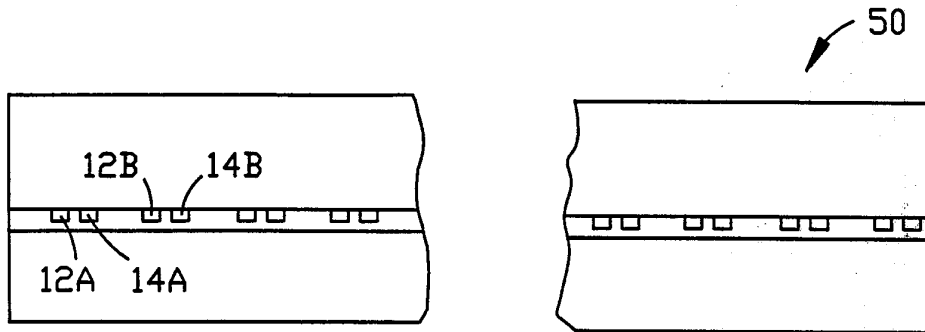

FIG. 13

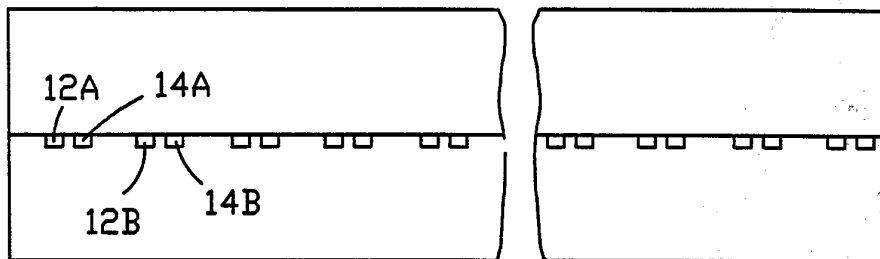
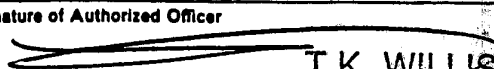

FIG. 14

INTERNATIONAL SEARCH REPORT

International Application No PCT/US 89/03069

I. CLASSIFICATION OF SUBJECT MATTER (if several classification symbols apply, indicate all) *		
According to International Patent Classification (IPC) or to both National Classification and IPC IPC5: G 02 B 6/42		
II. FIELDS SEARCHED		
Minimum Documentation Searched †		
Classification System	Classification Symbols	
IPC5	G 02 B	
Documentation Searched other than Minimum Documentation to the Extent that such Documents are Included in the Fields Searched ‡		
III. DOCUMENTS CONSIDERED TO BE RELEVANT §		
Category §	Citation of Document, ¶ with indication, where appropriate, of the relevant passages ¶¶	Relevant to Claim No. ¶¶
A	EP, A1, 0223414 (BRITISH TELECOMMUNICATIONS) 27 May 1987, see column 4, line 5 - line 10; figure 4 --	1-62
A	DE, A1, 3307669 (LICENTIA PATENT-VERWALTUNGS-GMBH) 6 September 1984, see figure 4; claims 1,9 --	1-62
A	US, A, 4702547 (R.S. ENOCHS) 27 October 1987, see abstract --	1-62
A	US, A, 4798439 (K. PRESTON) 17 January 1989, see abstract --	1-62
<p>* Special categories of cited documents: ¶¶</p> <p>"A" document defining the general state of the art which is not considered to be of particular relevance</p> <p>"E" earlier document but published on or after the international filing date</p> <p>"L" document which may throw doubts on priority claim(s) or which is cited to establish the publication date of another citation or other special reason (as specified)</p> <p>"O" document referring to an oral disclosure, use, exhibition or other means</p> <p>"P" document published prior to the international filing date but later than the priority date claimed</p> <p>"T" later document published after the international filing date or priority date and not in conflict with the application but cited to understand the principle or theory underlying the invention</p> <p>"X" document of particular relevance; the claimed invention cannot be considered novel or cannot be considered to involve an inventive step</p> <p>"Y" document of particular relevance; the claimed invention cannot be considered to involve an inventive step when the document is combined with one or more other such documents, such combination being obvious to a person skilled in the art.</p> <p>"&" document member of the same patent family</p>		
IV. CERTIFICATION		
Date of the Actual Completion of the International Search	Date of Mailing of this International Search Report	
31st January 1990	23. 02. 90	
International Searching Authority	Signature of Authorized Officer	
EUROPEAN PATENT OFFICE	 T.K. WILLIS	

III. DOCUMENTS CONSIDERED TO BE RELEVANT (CONTINUED FROM THE SECOND SHEET)		
Category *	Citation of Document, with indication, where appropriate, of the relevant passages	Relevant to Claim No
A	Patent Abstracts of Japan, Vol 11, No 32, P541, abstract of JP 61-201208, publ 1986-09-05 NEC CORP --	1-62
A	Patent Abstracts of Japan, Vol 7, No 93, P192, abstract of JP 58- 18612, publ 1983-02-03 OKI DENKI KOGYO K.K. -- -----	1-62

**ANNEX TO THE INTERNATIONAL SEARCH REPORT
ON INTERNATIONAL PATENT APPLICATION NO. PCT/US 89/03069**

SA 32326

This annex lists the patent family members relating to the patent documents cited in the above-mentioned international search report. The members are as contained in the European Patent Office EDP file on 08/11/89. The European Patent Office is in no way liable for these particulars which are merely given for the purpose of information.

Patent document cited in search report	Publication date	Patent family member(s)	Publication date
EP-A1- 0223414	27/05/87	EP-A- 0219356	22/04/87
		EP-A- 0219357	22/04/87
		EP-A- 0219358	22/04/87
		EP-A- 0219359	22/04/87
		WO-A- 87/02470	23/04/87
		WO-A- 87/02472	23/04/87
		WO-A- 87/02474	23/04/87
		WO-A- 87/02475	23/04/87
		WO-A- 87/02476	23/04/87
		WO-A- 87/02518	23/04/87
		EP-A- 0226296	24/06/87
		US-A- 4802727	07/02/89
		US-A- 4825262	25/04/89
		US-A- 4846930	11/07/89
		US-A- 4854658	08/08/89
		JP-T- 63501382	26/05/88
		JP-T- 63501383	26/05/88
		JP-T- 63501384	26/05/88
		JP-T- 63501385	26/05/88
		JP-T- 63501393	26/05/88
JP-T- 63501600	16/06/88		
DE-A1- 3307669	06/09/84	NONE	
US-A- 4702547	27/10/87	JP-A- 63036206	16/02/88
US-A- 4798439	17/01/89	EP-A- 0196875	08/10/86
		JP-A- 61240210	25/10/86

EPO FORM P0009

For more details about this annex : see Official Journal of the European Patent Office, No. 12/82