



INTERNATIONAL APPLICATION PUBLISHED UNDER THE PATENT COOPERATION TREATY (PCT)

<p>(51) International Patent Classification⁴ : A61C 8/00</p>	<p>A1</p>	<p>(11) International Publication Number: WO 88/ 10100</p> <p>(43) International Publication Date: 29 December 1988 (29.12.88)</p>
<p>(21) International Application Number: PCT/FI88/00096</p> <p>(22) International Filing Date: 15 June 1988 (15.06.88)</p> <p>(31) Priority Application Number: 872640</p> <p>(32) Priority Date: 15 June 1987 (15.06.87)</p> <p>(33) Priority Country: FI</p> <p>(71)(72) Applicant and Inventor: YLI-URPO, Antti [FI/FI]; Värttinäkatu 17, SF-20660 Littoinen (FI).</p> <p>(74) Agent: BERGGREN OY AB; Kansakoulukuja 3 A, SF-00100 Helsinki (FI).</p> <p>(81) Designated States: AT (European patent), AU, BE (European patent), CH (European patent), DE (European patent), DK, FI, FR (European patent), GB (European patent), HU, IT (European patent), JP, KR, LU (European patent),</p>		<p>NL (European patent), NO, SE (European patent), SU, US.</p> <p>Published <i>With international search report.</i></p>
<p>(54) Title: AN IMPLANT FOR THE REPLACEMENT OF A TOOTH OR A PART OF THE BONE TISSUE</p>		
<p>(57) Abstract</p>		
<p>The invention is directed to an implant for replacing a tooth or another part of bony tissue comprising a first non-resorbable layer (2) containing a bioglass i.e. CaP-glass; a second layer (4) of a mixture of CaP-glass and hydroxyl apatite resorbable into bone or biomass, and a slowly resorbable intermediate layer (3) containing CaP-glass and being disposed between said first and second layers; the inclusion of said hydroxyl apatite into the second layer (4) securing the stability of joining of the implant to the tissues. When strength is required the implant further comprises a metal core (1) to which the first layer (2) is attached. The invention is also directed to a granule filler usable in bone cavities and to a block for the replacement of bone.</p>		

FOR THE PURPOSES OF INFORMATION ONLY

Codes used to identify States party to the PCT on the front pages of pamphlets publishing international applications under the PCT.

AT	Austria	FR	France	ML	Mali
AU	Australia	GA	Gabon	MR	Mauritania
BB	Barbados	GB	United Kingdom	MW	Malawi
BE	Belgium	HU	Hungary	NL	Netherlands
BG	Bulgaria	IT	Italy	NO	Norway
BJ	Benin	JP	Japan	RO	Romania
BR	Brazil	KP	Democratic People's Republic of Korea	SD	Sudan
CF	Central African Republic	KR	Republic of Korea	SE	Sweden
CG	Congo	LI	Liechtenstein	SN	Senegal
CH	Switzerland	LK	Sri Lanka	SU	Soviet Union
CM	Cameroon	LU	Luxembourg	TD	Chad
DE	Germany, Federal Republic of	MC	Monaco	TG	Togo
DK	Denmark	MG	Madagascar	US	United States of America
FI	Finland				

An implant for the replacement of a tooth or a part of the bone tissue

The first attempts to place synthetic materials into the tissues were not made until the end of the eighteenth century, even though the subject has always been of interest to researchers. Those studies did not, however, bring about any satisfactory results. Instead, since the beginning of 1950's there has been varying success in placing titanium or tantalum metal blades into the bone, for example the jawbone.

Because of the difficult operation and the infection risks the large subperiosteal constructions and the large endosteal blades are becoming increasingly unpopular. These have been replaced by single screws (Brånemark, Straumann, Bioceram; ref. 1 Albrektson et al.; special reprint. The long term efficacy of currently used dental implants. A review and proposed criteria of success. Int. J. Oral and Max. Fac. Implants 1. 1986.) and by large conical cylinders resembling a single tooth root. (Frialit; ref. 1.). For the present methods it is common that the structure is placed into the alveolar bone. Thus it is possible to achieve a mechanical contact between the bone and the implant. The implant also penetrates the gingiva leaving a protrusion visible. This protrusion acts as a support for the protheses. To prevent the bacterial invasion, it is necessary that the epithelium should attach closely to the surface of the protrusion. To achieve this, it is required to always keep the area clean.

The attachment of the implant to the bone in the above methods has often been prevented by an infectious tissue

layer. It is possible to avoid this problem by a two stage operation technique in which the implant is totally screwed into the bone during the first stage (ad modum Brånemark, ref.1.) During the second stage of the operation, after 3-6 months, a protrusion is placed onto the implant. The results have been satisfactory.

Several variations of this have been introduced (IK-implant, IMZ-implant, Core-vent-implant). The material used are titanium or Co-Cr alloy with Ti by plasma spraying (TiO_2). The healing period is between 3 to 6 months, even though the manufacturer promises a possibility of instant loading after operations. The main disadvantages are the difficulty and the complexity of the method.

Simpler but less reliable is the Straumann-method, in which the hollow perforated cylinder protrudes out of the gingiva and is placed into the bone with only one operation. The material is a Co-Cr alloy, which is coated with TiO_2 by plasma spraying. These cylinders were withdrawn from the market in 1986 due to their unreliability.

At present a third type of implant is the polycrystalline Al_2O_3 -ceramic, Frialit-implant, which is placed directly after the tooth extraction into the widened root cavity. In shape this implant narrows towards the end with distinct steps. Because of the brittleness of the ceramic, these implants can only be used to support a single tooth which is under a small bite pressure, like in the case of front teeth.

The Japanese "Bioceram" Al-crystal-sapphire implant series by Kyoceran's implants that are smaller than the Frialit implants. These implants have a high value for other strength properties but their ductility is low. Also the

annealing has to be done carefully because of the brittleness of the material. The clinical results obtained do not correspond to the results given by the manufacturer. It appears that the bone attachment to Bioceram is not satisfactory. The reason for this is probably the inert nature and the low friction of the surface and the small surface area.

Even a long healing period does not seem to be enough for creating a strong attachment.

The minimum dimensions of the bone required for the large and simple attaching mechanisms are a depth of 10 mm and a breadth of 5.5 mm (Straumann). After tooth extraction the alveolar bone shrinks so much that there is only seldom enough left for the placement of such implants.

Both the titanium and the Al_2O_3 implants are too large, because the thin structure is not otherwise able to withstand the necessary mechanical stresses. In addition the manufacture of Ti is difficult. On the other hand the small implants (Brånemark) are complex and expensive, and the smallest, non-metallic (Bioceram) implants are brittle.

The used material types can be classified in the following way:

1. Metals, which are non-biocompatible:

Co-Cr-alloys, stainless steels, Ni-alloys, noble metals of type IV (Indumed, Holland).

2. Inert materials, which do not react with the tissues but which obtain a close contact with the bone:

Al_2O_3 -ceramics, Ta- and Ti-metal, their alloys

(TiV4Al6), carbon in its different forms, Teflon.

3. Bioactive materials, which attach actively and quickly to the bone i.e. they are surface-reactive and induce bone growth:

Hydroxyl apatite, CaP-glass and CaP-glass ceramics, "bioglasses".

Tricalciumphosphate i.e. TCP (Resorbs i.e. dissolves into the tissue),

The composition and the manufacturing method effects the resorption of these materials, and it varies from fully-resorbable for non-resorbable.

The following table represents the materials used and their properties.

Material	10^2 N/mm^2 Strength*	Bone bonding	Bonding to epithelium
Al-bioceramic material	9-7/7-4	+ +	+ +
Ca P-bioceramic material	9-0.5/2-0.5	+ +	+ +
Hydroxyl apatite	0.5/0.5	+ + +	+
Titanium 99,9	6/5	+	+
Ti-6Al-4V	7/6	<u>±</u>	<u>±</u>
Ti-6Al-4V+bioc.coat.	7/6	+ +	+
Steels	9.75/7.5	- -	- -
Co-alloys	8.5/7	-	-
Carbon	5.5	+	+
Plastic (containing Ca)	1-0.5	<u>±</u>	<u>±</u>
Noble metal	8.1/5.8 - 8.8/8.4	<u>±</u>	<u>±</u>
Tantalum		+	+

- * tensile strength/fracture stress
- +++ bonding to bone and to epithelium is very good and furthermore it induces bone growth.
- ++ bonding to bone is very good
- + bonding to bone is good
- ± bonding to bone is not well defined
- there is no bonding
- foreign particle reaction

At present the situation with the bioactive materials is as follows:

1. Joining hydroxyl apatite (HA) to metal is problematic. A mechanical joint has been attempted, which is problematic because of the brittleness of HA and it has not lead to satisfactory results. Also plasma spraying has been attempted; however it has not been demonstrated that the crystal structure would have been conserved, but the surface is transformed to the easily resorbed TCP, and therefore the joint is not durable (World High Tec. Congress, Milano 1986). Also the coral-based HA has not been any better than the synthetic one. However, HA is a cheap material, onto which the collagen fibers of the tissues attach and mineralize very well (Jarcho et al. several studies; ref. 2 de Putter, de Lange, de Groot: Per mucosal dental implants of dense hydroxyl apatite. Fixation in alveolar bone; Abstract: Int. congress on tissue integration in oral and maxillofacial reconstruction, Brussels 1985).

2. CaP-glasses and glass ceramics i.e. so called bio-glasses have been observed to obtain a good bone bonding (Hencke et al. 1971; ref. 3. Gross et Strung: The interface of various glasses and glass ceramics with a bony implantation bed. J. Biomed. Mat. Res. 251-271: 19, 1985).

The reaction is based on the creation of a SiO_2 -rich layer and on the precipitation of Ca and P. Ca and P then crystallize into HA around the collagen fibers attached to the surface.

An ideal method would fulfill the following requirements:

1. The implant must be small and strong and fully bio-compatible
 - thus the elastic Ti and potentially allergic Ni- and Cr-alloys are not viable.
 - remaining alternatives are sufficiently noble alloys (Au-, Pt-, Pd-alloys) or a hard Ti-alloy.
2. The implant must have a surface capable of bonding with bone and epithelium and it must have an enhancing effect to the bone growth.

Such surfaces are:

- HA = Hydroxyl apatite
- TCP = Tricalcium phosphate
- Bioglass or glass ceramic

At present there are implants that have a metal core in order to obtain a sufficiently small size and high strength. The core is coated with a bioglass (CaP-glass) which is non-resorbable due to its metal oxide content. In addition it has an outer layer, resorbable to bone or biomass, made of CaP-glass (ref. US. Pat. 4497629, Ogino et al.). Thus requirements 1 & 2 are superficially fulfilled; however, as the outer layer is resorbed, the inner layer does not achieve a satisfactory bonding to the tissue.

The attachment of dental implants has been improved by using hydroxyl apatite (HA). According to the present invention HA is used in the resorbable outer layer (resorbable CaP-glass + HA) and preferably also in the non-resorbable inner layer (non-resorbable CaP-glass + HA). In addition, the joining of these two layers is substantially enhanced with an intermediate layer, which has a CaP-glass of an adjustable resorption rate and which preferably contains HA. The invention is primarily characterized by the definitions in the attached claims.

More specifically the first non-resorbable layer contains 10 to 100 per cent by weight of CaP-glass and 0 to 90 per cent by weight of HA; the slowly resorbable intermediate layer contains 10 to 100 percent by weight of CaP-glass and 0 to 90 per cent by weight of HA; and the second resorbable layer contains 10 to 99 per cent by weight of CaP-glass and 1 to 90 per cent by weight of HA.

The first layer can be made non-resorbable by addition of a metal oxide or oxides thereto. Suitable metal oxides are the oxides of titanium, aluminium and zirconium. The first layer can also be made non-resorbable by varying the ratios between CaP, SiO_2 and/or Na_2O in the CaP-glass.

In the following, an application (A) of the invention, suitable for teeth i.e. intraosteal implant has been explained in detail.

Figure 1 represents the commonly used materials schematically.

Figure 2 represents a sample construction used in the tooth.

Figure 3 represents a subperiosteal implant i.e. an implant placed between the bone and the periosteum.

Figure 4 represents a joint prosthesis.

Figure 5 represents an intraosteal granule filler placed in a bone cavity.

Figure 6 represents a bone-subsidy of bioceramic block.

The represented implant has, according to the invention: A hard, surface oxidized metal core 1 (metal-to ceramic-alloys), with a thermal expansion coefficient of $10-15 \times 10^{-6} /K$, which is coated with a strong, dense and smooth non-resorbable bronzing bioglass, a mixture of CaP-glass and HA-ceramics 2, which has a smaller thermal expansion coefficient of $9-14 \times 10^{-6} /K$, which is coated with a mixture of CaP-glass and HA 3, which is sintered to a dense or porous almost non-resorbable layer, which is coated with a soft CaP-glass-HA mixture layer 4, which is resorbable, and limits the bone interface, which activates bone growth and results directly in a mechanical bone to implant attachment without inducing on excessive pressure on the bone.

The outer layer 4 can also be glazed when required. Thus the solution is a layer structure, in which the outer layer 4 resorbs and the inner layer 2 on the metal does not. Thus the resorption cannot advance all the way to the metal surface, since layer 2 contains resorption inhibitors (e.g. metal oxides). Between 2 & 4 exist a semiresorbable interlayer according to the description of the applied invention. In addition HA has been added to all layers 2, 3 & 4 of CaP-glass. The joining of the layers (and HA) to the metal and to each other is strong and stable due to the glass. In particular it must be noted that thus also HA is joined to the metal. In most cases, however, it is possible to achieve a satisfactory stable result, when the HA is not added to the layer 2 on the surface of the metal, or when the CaP-glass-HA mixture layers 3 is excluded.

When the strong structure is not needed, the metal core is excluded. This is possible for example when the implant is used for bone augmentation.

The resorption rate of the glass/HA mixture can be adjusted through control of the composition and with additives (e.g. metal oxides) just like the rate of pure CaP-glass can be. The CaP-glass/HA mixture surface of the invention attaches to the cells quickly (within 1-8 h) and the mineralization occurs also fast due to the existence the minerals of the implant. Such bone bonding is strong also in weak bone structures because of the inductive effect of the materials on bone growth. Thus this implant structure can be made smaller than before. In addition the metal core supports the ceramic structure attached to it when needed. By the glazing of the surface the advancing of the epithelium and loose connection tissue in between the bone and the implant can be prevented. Further applications of the invention can be obtained with different structures. These have been represented in the following table: There are other suitable compositions for the layers 2, 3 & 4:

- the surface of the metal can have transverse grooves
- the shape of the implant can be conical, cylindrical or threaded and its size can vary:
 - thickness e.g. 2.5 - 70 mm
 - length e.g. 7.0 - 700 mm
- a ceramic cap can be placed on the top of the implant for the healing period
- the implant can be embedded totally into the bone, under the periosteum or can be left partially outside the gingiva.

Other applications of the intraosteal implants in the invention are as follows:

B₁. A subperiosteal implant placed between the periosteum and the bone.

According to Figure 3; layers

1. metal
2. inert bioglass
3. HA/bioglass mixture
4. resorbable HA/bioglass mixture

B₂. The layers on the joint prostheses are the same as above and further more the joint surfaces are inert dense base glass ceramics or metal.

The structure in figure 4; layers 1, 2, 3 & 4 as before.

C. Intraosteal granule filling in bone cavities. Figure 5; layers 2, 3 & 4 as before. As filling 5 is used large granules that have a diameter between 1-5 mm, as follows:

- a. the core of the granule is slowly resorbable, the surface quickly resorbable
- b. a part of the granules are non-resorbable (2), a part slowly resorbable (3) and a part quickly resorbable (4)
- c. a part of the granules are slowly resorbable (3) and the rest of them either quickly (2) or non-resorbable (4)
- d. a part of the granules either slowly (3) or quickly (4) resorbable

D. A subperiosteal and periodontal granule filling is the same as before, but the granules are small and slowly resorbable. The diameter is between 0.1...1 mm and there are no layers.

In cases C and D there may be a hardenable plastic matrix which gives the desired shape according to the space.

E. Figure 6 represents an integrated alternative for granules, a bioceramic block for replacing bone. A block of ceramic can be made bone-bonding by having either partially or totally a slowly resorbable 3 or quickly resorbable surface layer of CaP-glass/HA mixture as shown in figure 6a. The block can be preattached to metallic parts as shown in figure 6b. The block consists these of slowly resorbable 3 and the brazing layer of non-resorbable 2 CaP-glass/HA mixture material. In addition the outer surface layer can be made of quickly resorbable (4) material if an enhanced bone bonding is desired.

Claims

1. An implant for replacing a tooth or another part of bony tissue comprising
 - a first non-resorbable layer (2) containing a bio-glass i.e. CaP-glass;
 - a second layer (4) of a mixture of CaP-glass and hydroxyl apatite resorbable into bone or biomass, and
 - a slowly resorbable intermediate layer (3) containing CaP-glass and being disposed between said first and second layers;the inclusion of said hydroxyl apatite into the second layer (4) securing the stability of joining of the implant to the tissues.
2. An implant according to claim 1 further comprising a metal core (1), when strength is required, to which said first layer (2) is attached.
3. An implant according to claim 1 or 2 wherein said first layer is made non-resorbable by addition of a metal oxide or oxides thereto.
4. An implant according to claim 1 wherein the intermediate layer (3) is a mixture of CaP-glass and hydroxyl apatite.
5. An implant according to claim 1 wherein the first layer (2) is a mixture of CaP-glass and hydroxyl apatite.
6. An implant for replacing a tooth according to claim 1 comprising
 - a metal core (1);
 - an inner non-resorbable layer (2) of a mixture of

CaP-glass and hydroxyl apatite attached to said metal core;

an outer resorbable layer (4) of a mixture of CaP-glass and hydroxyl apatite; and

a slowly resorbable intermediate layer (3) of a mixture of CaP-glass and hydroxyl apatite disposed between said inner and outer layers.

7. An implant according to claim 1 wherein the implant is used in joints and comprises

an inner resorbable layer (4) of a mixture of CaP-glass and hydroxyl apatite;

an outer non-resorbable layer (2) containing CaP-glass; and

a slowly resorbable intermediate layer (3) of a mixture of CaP-glass and hydroxyl apatite;

when the bone substance of the joint is inside, but vice versa when the bone substance of the joint is outside.

8. A granule filler usable in bone cavities comprising granules having an inner non-resorbable layer (2) containing CaP-glass;

an outer resorbable layer (4) of a mixture of CaP-glass and hydroxyl apatite; and

a slowly resorbable intermediate layer (3) of a mixture of CaP-glass and hydroxyl apatite;

said granules being attached to the bone and to each other via the bone as they are resorbed.

9. A block for the replacement of bone which is partially or totally made of a slowly (3) or quickly (4) resorbable mixture of CaP-glass and hydroxyl apatite.

10. A block according to claim 9 further comprising metal parts (1) being attached to the block by means of a non-resorbable mixture (2) of CaP-glass and hydroxyl apatite.

1/3

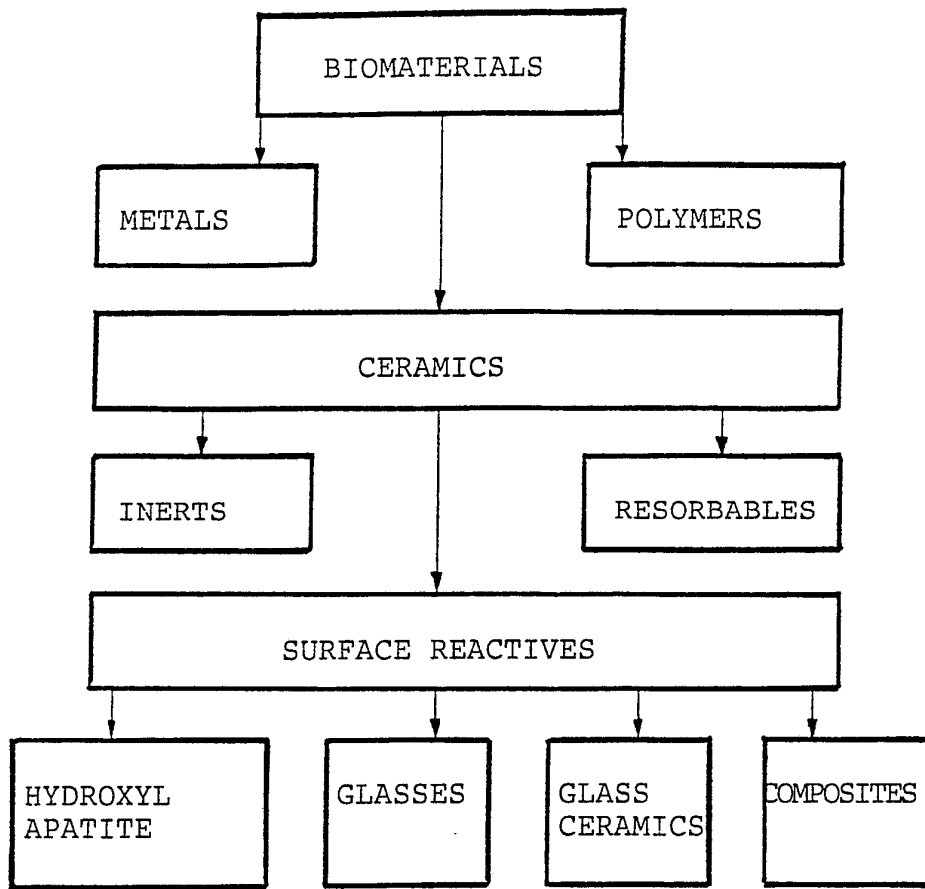

FIG. 1

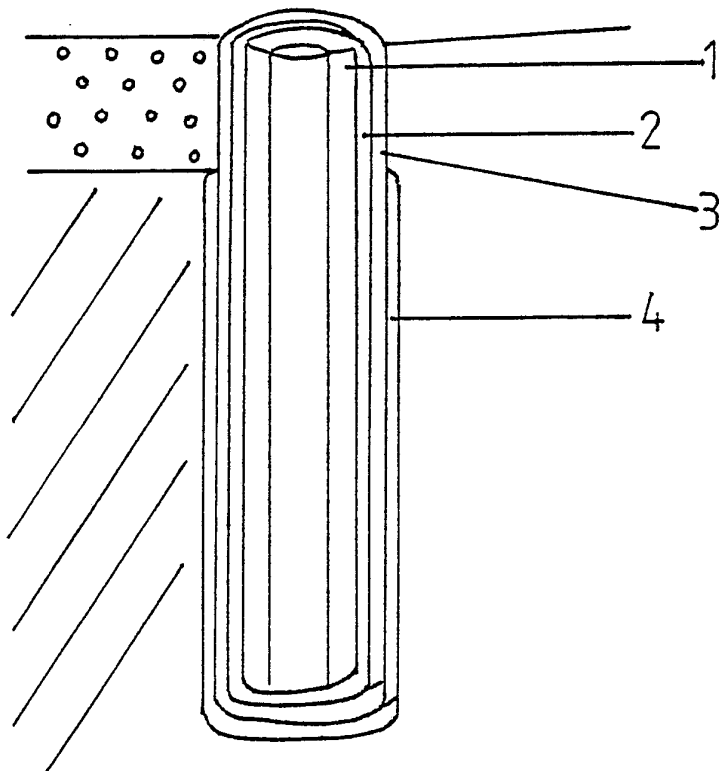

FIG. 2

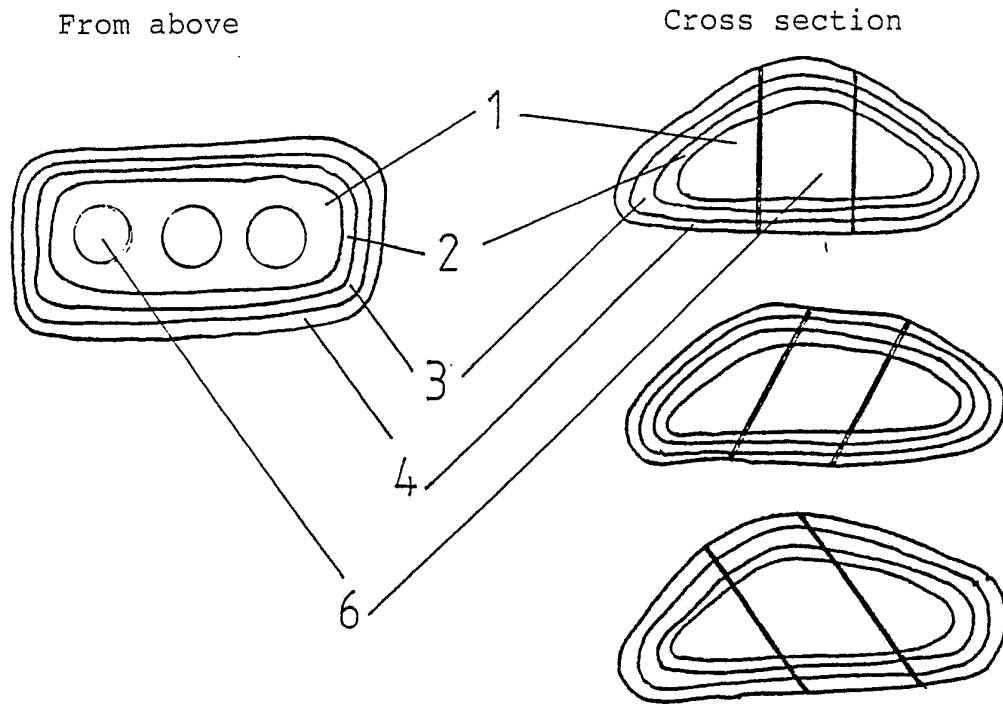

FIG. 3

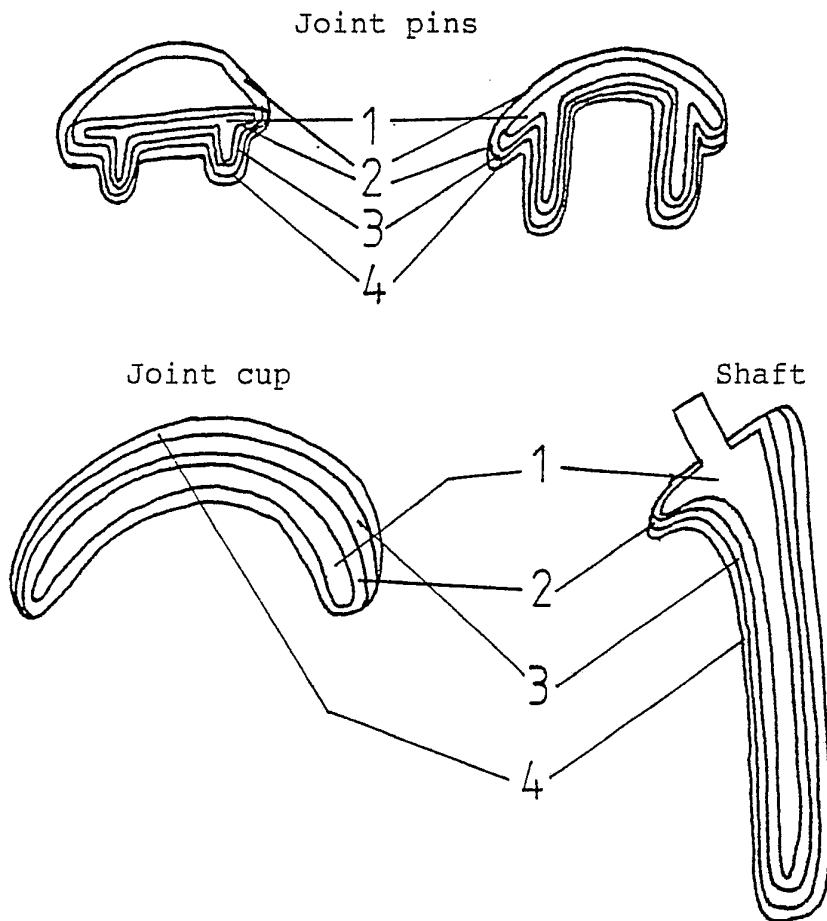

FIG. 4

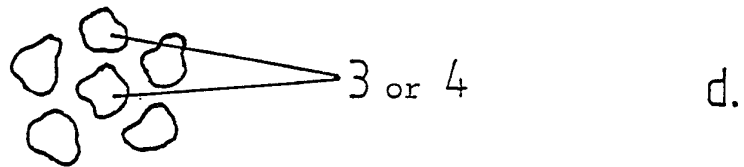
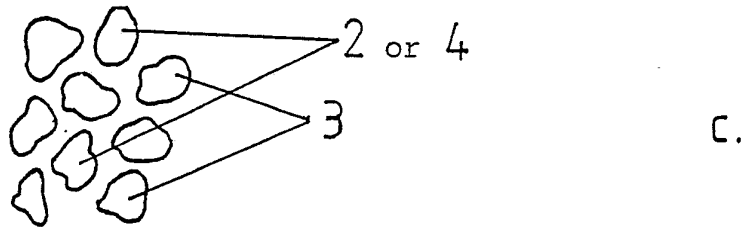
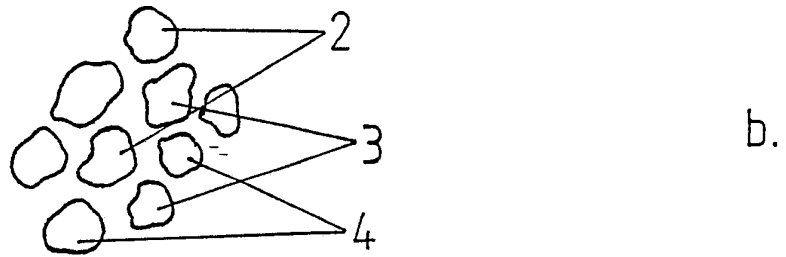
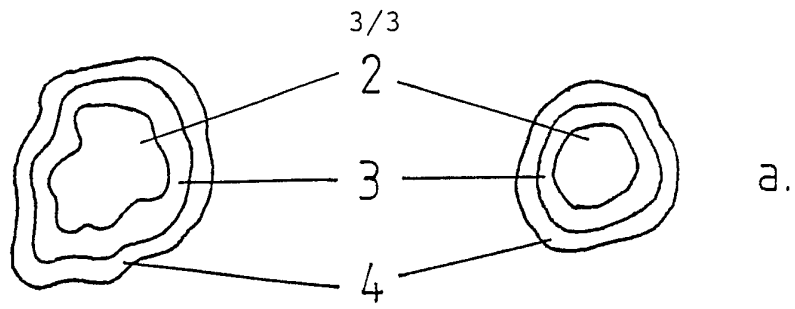

FIG. 5

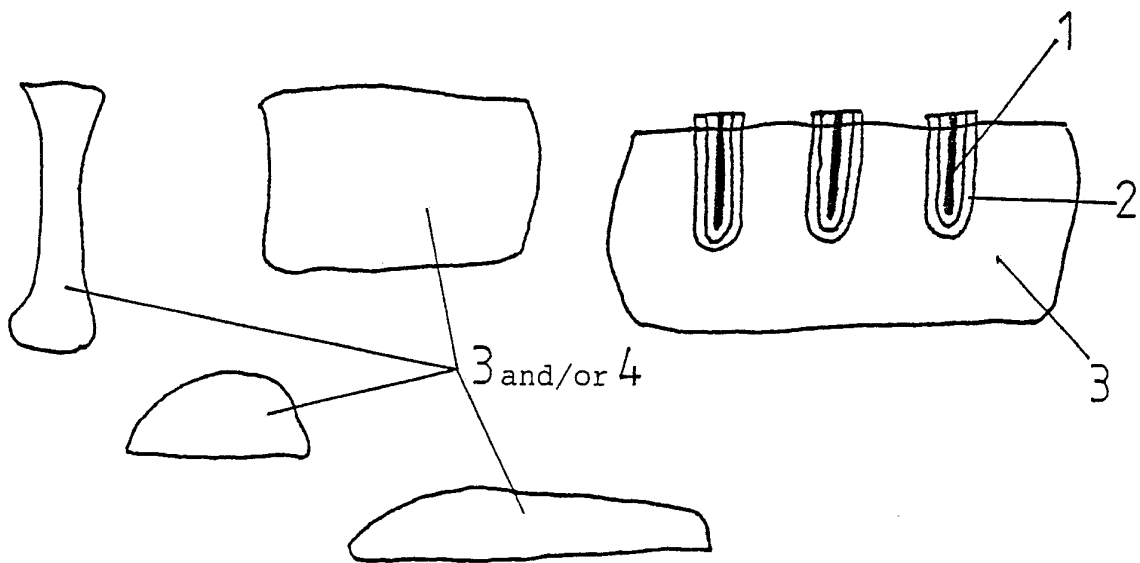



FIG. 6

INTERNATIONAL SEARCH REPORT

International Application No PCT/FI88/00096

I. CLASSIFICATION OF SUBJECT MATTER (if several classification symbols apply, indicate all) ⁶				
According to International Patent Classification (IPC) or to both National Classification and IPC ⁴				
A 61 C 8/00				
II. FIELDS SEARCHED				
Minimum Documentation Searched ⁷				
Classification System	Classification Symbols			
IPC 4	A 61 C 8/00; A 61 K 6/06			
US C1	433: 173-175, 201			
Documentation Searched other than Minimum Documentation to the Extent that such Documents are Included in the Fields Searched ⁸				
SE, NO, DK, FI classes as above				
III. DOCUMENTS CONSIDERED TO BE RELEVANT ⁹				
Category [*]	Citation of Document, ¹¹ with indication, where appropriate, of the relevant passages ¹²	Relevant to Claim No. ¹³		
A	SE,B, 416 443 (SUMITOMO CHEMICAL CO) 5 January 1981	1-10		
A	EP,A1, 0 006 544 (BATTELLE-INSTITUT e.V.) 9 January 1980	1-10		
A	EP,A1, 0 023 608 (RIESS, GUIDO) 11 February 1981	1-10		
A	US,A, 4 270 905 (MOHAMMED) 2 June 1981	1-10		
A	US,A, 4 483 678 (NISHIO ET AL) 20 November 1984	1-10		
A	US,A, 4 497 629 (OGINO ET AL) 5 February 1985	1-10		
<table style="width: 100%; border: none;"> <tr> <td style="width: 50%; vertical-align: top;"> <p>[*] Special categories of cited documents: ¹⁰</p> <p>"A" document defining the general state of the art which is not considered to be of particular relevance</p> <p>"E" earlier document but published on or after the international filing date</p> <p>"L" document which may throw doubts on priority claim(s) or which is cited to establish the publication date of another citation or other special reason (as specified)</p> <p>"O" document referring to an oral disclosure, use, exhibition or other means</p> <p>"P" document published prior to the international filing date but later than the priority date claimed</p> </td> <td style="width: 50%; vertical-align: top;"> <p>"T" later document published after the international filing date or priority date and not in conflict with the application but cited to understand the principle or theory underlying the invention</p> <p>"X" document of particular relevance; the claimed invention cannot be considered novel or cannot be considered to involve an inventive step</p> <p>"Y" document of particular relevance; the claimed invention cannot be considered to involve an inventive step when the document is combined with one or more other such documents, such combination being obvious to a person skilled in the art.</p> <p>"Z" document member of the same patent family</p> </td> </tr> </table>			<p>[*] Special categories of cited documents: ¹⁰</p> <p>"A" document defining the general state of the art which is not considered to be of particular relevance</p> <p>"E" earlier document but published on or after the international filing date</p> <p>"L" document which may throw doubts on priority claim(s) or which is cited to establish the publication date of another citation or other special reason (as specified)</p> <p>"O" document referring to an oral disclosure, use, exhibition or other means</p> <p>"P" document published prior to the international filing date but later than the priority date claimed</p>	<p>"T" later document published after the international filing date or priority date and not in conflict with the application but cited to understand the principle or theory underlying the invention</p> <p>"X" document of particular relevance; the claimed invention cannot be considered novel or cannot be considered to involve an inventive step</p> <p>"Y" document of particular relevance; the claimed invention cannot be considered to involve an inventive step when the document is combined with one or more other such documents, such combination being obvious to a person skilled in the art.</p> <p>"Z" document member of the same patent family</p>
<p>[*] Special categories of cited documents: ¹⁰</p> <p>"A" document defining the general state of the art which is not considered to be of particular relevance</p> <p>"E" earlier document but published on or after the international filing date</p> <p>"L" document which may throw doubts on priority claim(s) or which is cited to establish the publication date of another citation or other special reason (as specified)</p> <p>"O" document referring to an oral disclosure, use, exhibition or other means</p> <p>"P" document published prior to the international filing date but later than the priority date claimed</p>	<p>"T" later document published after the international filing date or priority date and not in conflict with the application but cited to understand the principle or theory underlying the invention</p> <p>"X" document of particular relevance; the claimed invention cannot be considered novel or cannot be considered to involve an inventive step</p> <p>"Y" document of particular relevance; the claimed invention cannot be considered to involve an inventive step when the document is combined with one or more other such documents, such combination being obvious to a person skilled in the art.</p> <p>"Z" document member of the same patent family</p>			
IV. CERTIFICATION				
Date of the Actual Completion of the International Search	Date of Mailing of this International Search Report			
1988-09-14	1988 -09- 1 6			
International Searching Authority	Signature of Authorized Officer			
Swedish Patent Office	 Jack Hedlund			