

(19)



(11)

EP 3 900 557 B1

(12)

EUROPEAN PATENT SPECIFICATION

(45) Date of publication and mention of the grant of the patent:
07.12.2022 Bulletin 2022/49

(51) International Patent Classification (IPC):
A41D 13/015 ^(2006.01) **A41D 27/26** ^(2006.01)
A41D 27/12 ^(2006.01) **A41D 27/08** ^(2006.01)
A44B 18/00 ^(2006.01) **A41D 13/05** ^(2006.01)
A41D 31/12 ^(2019.01)

(21) Application number: **21179423.5**

(22) Date of filing: **27.03.2018**

(52) Cooperative Patent Classification (CPC):
A41D 13/015; A41D 13/0562; A41D 27/26;
A41D 31/12; A44B 18/0069

(54) APPAREL WITH SELECTIVELY ATTACHABLE AND DETACHABLE ELEMENTS

KLEIDUNG MIT SELEKTIV FIXIERBAREN UND LÖSBAREN ELEMENTEN

VÊTEMENT POURVU D'ÉLÉMENTS POUVANT ÊTRE FIXÉS ET DÉTACHÉS DE MANIÈRE SÉLECTIVE

(84) Designated Contracting States:
AL AT BE BG CH CY CZ DE DK EE ES FI FR GB
GR HR HU IE IS IT LI LT LU LV MC MK MT NL NO
PL PT RO RS SE SI SK SM TR

(72) Inventors:
 • **HENRY, Ryan P.**
Beaverton, 97005-6453 (US)
 • **TURNER, David**
Beaverton, 97005-6453 (US)

(30) Priority: **27.03.2017 US 201715470209**

(74) Representative: **Müller-Boré & Partner**
Patentanwälte PartG mbB
Friedenheimer Brücke 21
80639 München (DE)

(43) Date of publication of application:
27.10.2021 Bulletin 2021/43

(62) Document number(s) of the earlier application(s) in accordance with Art. 76 EPC:
18717806.6 / 3 573 487

(56) References cited:
US-A1- 2008 189 830 US-A1- 2010 024 089
US-A1- 2015 096 659 US-A1- 2017 196 277

(73) Proprietor: **NIKE Innovate C.V.**
Beaverton, OR 97005-6453 (US)

EP 3 900 557 B1

Note: Within nine months of the publication of the mention of the grant of the European patent in the European Patent Bulletin, any person may give notice to the European Patent Office of opposition to that patent, in accordance with the Implementing Regulations. Notice of opposition shall not be deemed to have been filed until the opposition fee has been paid. (Art. 99(1) European Patent Convention).

Description

BACKGROUND OF THE INVENTION

[0001] Articles of apparel intended for use during athletic activities generally exhibit characteristics that enhance the performance, comfort, or protection of a wearer. As an example, apparel may incorporate a stretch material that provides a relatively tight fit, thereby imparting the wearer with a lower profile that minimizes wind resistance. Apparel may also be formed from a material that wicks moisture away from the wearer in order to reduce the quantity of perspiration that accumulates adjacent to the skin. Furthermore, apparel may incorporate materials that attenuate compression forces (i.e., impart padding or cushioning) to provide impact protection to areas of the wearer. Accordingly, the configurations of articles of apparel for athletic activities may be specifically selected to enhance the performance or comfort of the wearer.

[0002] Document US 2015/096659 A1 describes a method of making a mechanical fastener. The method includes providing a slit web having mechanical fastening elements, applying tension to the slit web in the machine direction, and spreading the slit web in the cross-machine direction by directing its side edges over two rotating diverging disks to provide a spread mechanical fastening web. The slit web includes a plurality of interrupted slits that are interrupted by intact bridging regions of the web. The two rotating diverging disks are laterally spaced and have a support surface between them that contacts the slit web during the spreading. The spread mechanical fastening web includes multiple strands of the slit web attached to each other at least at some of the intact bridging regions and separated from each other between at least some of the intact bridging regions.

[0003] Document US 2008/189830 A1 describes an article of clothing that includes a clothing product, a display portion attached to the clothing product, and a plurality of display items. The display portion has a suppleness and softness substantially the same as that of the clothing product. The display portion includes at least some of a top layer of loop fabric, a middle layer of foam, and a bottom layer of lining material. The display portion may be laminated together, and may be attached to the clothing by at least one of a stitch other than a single stitch, and a heat fusible layer. The display portion is attached onto the clothing product at a position for displaying at least one of the pluralities of display items. The display items are attached to the display portion using hook-and-loop fastener system. Each of the plurality of display items are die-cut from a hook material.

[0004] Document US 2010/024089 A1 describes an article of apparel having a surface with a first part of a fastening system, and an attachment element having an outer area with a second part of the fastening system. The first part of the fastening system is joinable to the second part of the fastening system to attach the attach-

ment element to the apparel. The first part of the fastening system is also separable from the second part of the fastening system to separate the attachment element from the apparel. Document US 2010/024089 A1 describes a pad according to the preamble of claim 1.

[0005] Document US 2017/196277 A1 describes an article of apparel having a surface with a first part of a fastening system, and an attachment element having an outer area with a second part of the fastening system. The first part of the fastening system is joinable to the second part of the fastening system to attach the attachment element to the apparel. The first part of the fastening system is also separable from the second part of the fastening system to separate the attachment element from the apparel.

SUMMARY OF THE INVENTION

[0006] Various non-claimed apparel systems are disclosed below as including an article of apparel and at least one attachment element. The apparel has a surface with a first part of a fastening system, and the attachment element has an outer area with a second part of the fastening system. The first part of the fastening system is joinable to the second part of the fastening system to attach the attachment element to the apparel. The first part of the fastening system is also separable from the second part of the fastening system to separate the attachment element from the apparel. The attachment element may be formed from a polymer foam material, may include a fluid-filled chamber, or may incorporate an electronic device, for example. In some configurations, the attachment element is secured to an exterior of the apparel. In other configurations, the attachment element is secured between two layers of the apparel.

[0007] Further, in accordance with aspects herein, a non-claimed article is disclosed having a textile layer having a first surface, a second surface, and a textile layer thickness between the first surface and the second surface, a cushion layer having a third surface, a fourth surface, and a cushion layer thickness between the third surface and the fourth surface, wherein the second surface of the textile layer is coupled to the third surface of the cushion layer, and an attachment layer having a fifth surface, a sixth surface, and an attachment layer thickness, wherein the fifth surface of the attachment layer is coupled to the fourth surface of the cushion layer.

[0008] In accordance with other aspects herein, a non-claimed garment is disclosed comprising a textile material having a first surface that faces away from a wearer when the garment is worn and a second surface that faces towards the wearer when the garment is worn, the second surface having a loop component of a hook-and-loop attachment system. Additionally, each of the one or more attachment elements comprises a first layer having a hook component of the hook-and-loop attachment system, the hook component being releasably attachable to the loop component, a second layer coupled to the first

layer, the second layer comprising a foam material, and a third layer coupled to the second layer, the third layer comprising a textile layer having a wearer-facing surface that faces towards the wearer when the garment is worn.

[0009] The invention is a pad comprising a cushion layer having a first surface, a second surface, and a cushion-layer thickness between the first surface and the second surface, an attachment layer having a third surface, a fourth surface, and an attachment layer thickness between the third surface and the fourth surface.

[0010] The attachment layer includes either a hook component or a loop component of a hook-and-loop attachment system, and where the third surface of the attachment layer is coupled to the second surface of the cushion layer, a first incision extending entirely through the cushion layer and the attachment layer, from the first surface to the fourth surface, a second incision that is collinear with the first incision and that extends entirely through the cushion layer and the attachment layer, from the first surface to the fourth surface, and a connecting portion separating an end of the first incision from an end of the second incision, the connecting portion including a portion of the cushion layer and a portion of the attachment layer.

[0011] The invention is defined by the appended claims. To gain an improved understanding of the advantages and features of novelty, however, reference may be made to the following descriptive matter and accompanying figures that describe and illustrate various configurations and concepts related to the invention. Additional objects, advantages, and novel features of the invention will be set forth in part in the description which follows, and in part will become apparent to those skilled in the art upon examination of the following, or may be learned by practice of the invention.

BRIEF DESCRIPTION OF THE DRAWING

[0012] The present invention is described in detail below with reference to the attached figures. Directly below is a listing of the figures together with a brief description.

Figure 1 is a front elevational view of a first article of apparel.

Figures 2A-2C are front elevational views of the first article of apparel in combination with a plurality of attachment elements.

Figures 3A-3E are front elevational views of further configurations of the first article of apparel.

Figure 4 is a front elevational view of a second article of apparel.

Figures 5A-5C are front elevational views of the second article of apparel in combination with a plurality of attachment elements.

Figures 6A-6E are front elevational views of further configurations of the second article of apparel.

Figure 7 is a top plan view of a first attachment element.

Figure 8 is a bottom plan view of the first attachment element.

Figure 9 is a cross-sectional view of the first attachment element, as defined by section line 9-9 in Figure 7.

Figure 10 is a cross-sectional view corresponding with Figure 9 and depicting the first attachment element in a flexed configuration.

Figures 11A-11D are cross-sectional views corresponding with Figure 9 and depicting further configurations of the first attachment element.

Figure 12 is a front elevational view of the first article of apparel in combination with a pair of the first attachment element.

Figure 13 is a cross-sectional view of the first article of apparel and a portion of the first attachment element, as defined by section line 13-13 in Figure 12. Figure 14 is a top plan view of a second attachment element.

Figure 15 is a bottom plan view of the second attachment element.

Figure 16 is a front elevational view of the second article of apparel in combination with a pair of the second attachment element.

Figure 17 is a cross-sectional view of the second article of apparel and the second attachment element, as defined by section line 17-17 in Figure 16. Figure 18 is a top plan view of a third attachment element.

Figure 19 is a bottom plan view of the third attachment element.

Figure 20 is a top plan view of a fourth attachment element.

Figure 21 is a bottom plan view of the fourth attachment element.

Figure 22 is a cross-sectional view of the fourth attachment element, as defined by section line 22-22 in Figure 20.

Figure 23 is a top plan view of a fifth attachment element.

Figure 24 is a bottom plan view of the fifth attachment element.

Figure 25 is a front elevational view of a third article of apparel incorporating a plurality of attachment elements.

Figure 26 is an exploded front elevational view of the third article of apparel and the attachment elements.

Figure 27 is a cross-sectional view of the third article of apparel and one of the attachment elements, as defined by section line 27-27 in Figure 25.

Figures 28A-28D are front elevational views of further configurations of the third article of apparel and the attachment elements.

Figure 29 is a front elevational view of a fourth article of apparel incorporating a plurality of attachment elements.

Figure 30 is an exploded front elevational view of the fourth article of apparel and the attachment ele-

ments.

Figure 31 is a cross-sectional view of the fourth article of apparel and one of the attachment elements, as defined by section line 31-31 in Figure 29.

Figures 32A-32D are front elevational views of further configurations of the fourth article of apparel and the attachment elements.

Figure 33 is a top plan view of a sixth attachment element.

Figure 34 is a bottom plan view of the sixth attachment element.

Figure 35 is a cross-sectional view of the sixth attachment element, as defined by section line 35-35 in Figure 33.

Figure 36 is a cross-sectional view corresponding with Figure 35 and depicting the sixth attachment element in a flexed configuration.

Figure 37 is a top plan view of a seventh attachment element.

Figure 38 is a bottom plan view of the seventh attachment element.

Figure 39 is a top plan view of an eighth attachment element.

Figure 40 is a bottom plan view of the eighth attachment element.

Figure 41 is a cross-sectional view of the eighth attachment element, as defined by section line 41-41 in Figure 39.

Figure 42 is a perspective view of an exemplary article.

Figure 43 is a side view of an exemplary article.

Figure 44 is a perspective view of an exemplary article having some of the attachment elements separated from the remainder of the exemplary article.

Figure 45 is a perspective view of an attachment element separated from the exemplary article.

Figure 46 is a cross-sectional view of the attachment element illustrated in Figure 45 taken along cut line 46-46.

Figure 47 is a lower body garment having a plurality of attachment elements affixed to an outer surface.

Figure 48 is an upper body garment having a plurality of attachment elements affixed to an inner surface.

DETAILED DESCRIPTION OF THE INVENTION

[0013] The following discussion and accompanying figures disclose concepts associated with various articles of apparel and attachment elements. In general, the attachment elements may be repeatedly attached to and detached from various areas of the apparel. A variety of attachment element configurations may be utilized, depending upon the activities, particular needs, and preferences of a wearer. For example, the attachment elements may be (a) foam members, gas-filled chambers, or plates that attenuate compression forces (i.e., impart padding or cushioning) to provide impact protection to areas of the wearer where the attachment elements are

located, (b) liquid-filled chambers that impart either heating or cooling to areas of the wearer where the attachment elements are located, or (c) electronic devices that provide information or enjoyment to the wearer, such as, mobile phones, portable music players, timing devices, heart-rate monitors, locator beacons, global positioning systems, or mobile computing devices.

[0014] Although a variety of types of apparel may be utilized with the attachment elements, examples of both shirt-type garments and pants-type garments are disclosed in the following discussion and accompanying figures. Shirt-type garments include any of a plurality of garments that cover a portion of a torso of the wearer and may extend over arms of the wearer. Examples of shirt-type garments include long-sleeved shirts, short-sleeved shirts, tank tops, undershirts, jackets, and coats. Similarly, pants-type garments include any of a plurality of garments that cover a portion of a pelvic region of the wearer and may extend over legs of the wearer. Examples of pants-type garments include pants, shorts, briefs, jeans, and underwear. In some configurations, the articles of apparel may be combinations of shirt-type garments and pants-type garments, including bodysuits, leotards, unitards, and wetsuits. In addition, the articles of apparel may have configurations that cover other areas of the wearer, such as hats, helmets, gloves, socks, and footwear, for example. Accordingly, a variety of types of articles of apparel may be utilized.

30 First Shirt-Type Garment Configuration

[0015] An article of apparel 100 having the configuration of a shirt-type garment is depicted in Figure 1. Apparel 100 includes a torso region 101 and a pair of arm regions 102 and 103 that extend outward from torso region 101. Torso region 101 corresponds with a torso of a wearer and covers at least a portion of the torso when worn. An upper area of torso region 101 defines a neck opening 104 through which the neck and head of the wearer protrude when apparel 100 is worn. Similarly, a lower area of torso region 101 defines a waist opening 105 through which the waist or pelvic area of the wearer protrudes when apparel 100 is worn. Arm region 102 corresponds with a right arm of the wearer and covers at least a portion of the right arm, and arm region 103 corresponds with a left arm of the wearer and covers at least a portion of the left arm. Each of arm regions 102 and 103 define a wrist opening 106 through which a hand and wrist of the wearer protrude when apparel 100 is worn. Additionally, apparel 100 includes an outer surface 107 that faces away from the wearer, and apparel 100 includes an inner surface 108 that faces toward the wearer and may contact the wearer when apparel 100 is worn.

[0016] A variety of attachment elements 111-115 are secured to apparel 100, as depicted in Figure 2A. More particularly, attachment elements 111-115 may be secured to outer surface 107 in any of torso region 101 and arm regions 102 and 103, although attachment elements

111-115 may be secured to inner surface 108 in some configurations of apparel 100. Attachment elements 111-115 may be any of foam members, fluid-filled chambers (e.g., gas-filled or liquid-filled), plates, or electronic devices, for example. Similarly, the shapes and sizes of attachment elements 111-115 may vary significantly. For example, attachment elements 111 and 114 exhibit generally rectangular configurations, whereas attachment element 112 is generally triangular, attachment element 113 is generally circular, and attachment element 115 exhibits a non-geometrical form. The thicknesses of attachment elements 111-115 may also vary significantly to include generally flat, nonuniform, or protruding configurations, depending upon the composition and intended use of attachment elements 111-115. Accordingly, the configurations of attachment elements 111-115 may vary significantly.

[0017] Attachment elements 111-115 are secured to apparel 100 in a variety of different locations. More particularly, attachment element 111 is secured to an upper area of torso region 101, attachment element 112 is secured to a lower area of torso region 101, attachment element 113 is secured to a side area of the torso region 101, attachment element 114 is secured to arm region 102, and attachment element 115 is secured to arm region 103. Apparel 100 and attachment elements 111-115 each incorporate portions of a fastening system that is utilized to secure attachment elements 111-115 to outer surface 107. A variety of fastening systems may be utilized, including hook-and-loop fastening systems (e.g., VELCRO, which is manufactured by VELCRO USA, Inc. of Manchester, New Hampshire, United States of America), magnetic fastening systems, adhesive fastening systems, and button-type fastening systems, for example. For purposes of reference, portions of apparel 100, other articles of apparel, and other elements incorporating the fastening system or a part of the fastening system are depicted as having a stippled or otherwise textured configuration in the figures.

[0018] In addition to attaching or otherwise securing attachment elements 111-115 to apparel 100, the fastening system permits attachment elements 111-115 to be detached or otherwise separated from apparel 100. Referring to Figure 2B, therefore, each of attachment elements 111-115 are depicted as being separated from apparel 100. Moreover, the fastening system also permits attachment elements 111-115 to be (a) repeatedly attached to and detached from apparel 100, (b) attached to apparel 100 in a variety of different locations, and (c) attached in a variety of different orientations. Referring to Figure 2C, therefore, each of attachment elements 111-115 are depicted as being re-attached to apparel 100 in different locations and with different orientations.

[0019] A variety of materials may be utilized in manufacturing apparel 100. In general, apparel 100 may be formed from knitted, woven, or non-woven textile materials that include rayon, nylon, polyester, polyacrylic, cotton, wool, or silk, for example. Although apparel 100 may

be knitted as a unitary (i.e., one-piece) article, apparel 100 may also be formed from a plurality of textile elements that are sewn, bonded, adhered, or otherwise joined together to form torso region 101 and arm regions 102 and 103. As depicted in Figure 1, for example, a variety of seams 109 join textile elements that form arm regions 102 and 103 to textile elements that form torso region 101, and a seam 109 joins a collar in the area of neck opening 104. In some configurations, the textile materials may include coatings that form a breathable and water-resistant barrier, or polymer sheets may be utilized in place of textile materials. Apparel 100 may also be formed from laminated or otherwise layered materials that include two or more layers of textile materials, polymer sheets, or combinations of textile materials and polymer sheets.

[0020] Depending upon the specific fastening system that is utilized for attachment elements 111-115, apparel 100 may also incorporate elements related to the fastening system. For example, magnetic elements or buttons may be incorporated into the textile materials of apparel 100 when a magnetic fastening system or a button-type fastening system is utilized. As another example, elements of either a hook part or a loop part of a hook-and-loop fastening system may be secured to apparel 100 in order to form a portion of outer surface 107. Alternatively, the textile material forming apparel 100 may be manufactured to define the hook part or the loop part of the hook-and-loop fastening system. That is, the hook part or the loop part of the hook-and-loop fastening system may be knitted as an integral part of the textile material forming apparel 100. An advantage of this configuration is that additional elements (e.g., magnetic elements, buttons, strips of the hook part or the loop part) are absent from apparel 100, which decreases the number of components within apparel 100 and simplifies the overall manufacturing process. An example of a suitable material incorporating the loop part of the hook-and-loop fastening system is manufactured by RUEY TAY of Taipei, Taiwan, Republic of China and is a warp knit mesh that includes ninety-one percent polyester having 1/75/72 textured microfiber semi-dull and nine percent spandex (i.e., elastane).

[0021] Apparel 100 is depicted as having the configuration of a shirt-type garment, particularly a long-sleeved shirt. In some configurations, apparel 100 may be intended for use as a compression garment. In addition to therapeutic uses, compression garments are often worn by athletes as a base layer under jerseys or other athletic apparel. In general, compression garments or other garments intended as base layers (a) exhibit a relatively tight fit that lays adjacent to the skin of the wearer and (b) stretch to conform with the contours of the wearer. While the textile materials forming compression garments may have one-directional stretch of, for example, more than ten percent prior to tensile failure, the textile materials forming other compression garments have two-directional stretch of at least thirty percent prior to tensile failure.

Accordingly, when apparel 100 is formed to have a relatively tight fit and to stretch to conform with the contours of the wearer, the textile materials forming apparel 100 may have two-directional stretch of at least thirty percent prior to tensile failure.

[0022] Substantially all of outer surface 107 has a configuration that provides locations for securing attachment elements 111-115. That is, at least ninety percent of outer surface 107 provides locations for securing attachment elements 111-115. When, for example, the loop part of the hook-and-loop fastening system is knitted as an integral part of the textile material forming apparel 100, substantially all of outer surface 107 may be formed from the textile material. In some configurations, however, only portions of outer surface 107 may provide locations for securing attachment elements 111-115. That is, a part of the fastening system may be absent from portions of outer surface 107 or textile materials that do not provide locations for securing attachment elements 111-115 may be utilized for portions of outer surface 107.

[0023] Although substantially all of outer surface 107 may have a configuration that provides locations for securing attachment elements 111-115, apparel 100 is depicted in Figure 3A as having a configuration wherein the fastening system is absent from torso region 101. Given that portions of apparel 100 incorporating the fastening system or a part of the fastening system are depicted as having a stippled or otherwise textured configuration in the figures, areas without the stippled or otherwise textured configuration represent areas where the fastening system or a part of the fastening system is absent. Similarly, Figure 3B depicts a configuration wherein the fastening system is absent in arm regions 102 and 103, but forms at least seventy-five percent of outer surface 107. A configuration wherein the fastening system is present in only central and upper areas of torso region 101, but forms at least fifty percent of outer surface 107, is depicted in Figure 3C. Additionally, a configuration wherein the fastening system is present in only selected areas of regions 101-103 is depicted in Figure 3D. In each of the configurations of Figures 3A-3D, seams 109 may be utilized to join textile elements without the fastening system to textile elements with the fastening system. Although apparel 100 is depicted as having the configuration of a long-sleeved shirt in each of Figures 1-3D, concepts associated with apparel 100 may also be incorporated into other shirt-type garments. As an example, apparel 100 is depicted as having the configuration of a short-sleeved shirt in Figure 3E, but may also be a tank top, undershirt, jacket, or coat.

First Pants-Type Garment Configuration

[0024] An article of apparel 200 having the configuration of a pants-type garment is depicted in Figure 4. Apparel 200 includes a pelvic region 201 and a pair of leg regions 202 and 203 that extend outward from pelvic region 201. Pelvic region 201 corresponds with a pelvic

area of a wearer and covers at least a portion of the pelvic area when worn. An upper area of pelvic region 201 defines a waist opening 204 that extends around the waist when apparel 200 is worn. Leg region 202 corresponds with a right leg of the wearer and covers at least a portion of the right leg, and leg region 203 corresponds with a left leg of the wearer and covers at least a portion of the left leg. Each of leg regions 202 and 203 define an ankle opening 205 through which a foot and ankle of the wearer protrude when apparel 200 is worn. Additionally, apparel 200 includes an outer surface 207 that faces away from the wearer, and apparel 200 includes an inner surface 208 that faces toward the wearer and may contact the wearer when apparel 200 is worn.

[0025] A variety of attachment elements 211-214 are secured to apparel 200, as depicted in Figure 5A. More particularly, attachment elements 211-214 may be secured to outer surface 207 in any of pelvic region 201 and leg regions 202 and 203, although attachment elements 211-214 may be secured to inner surface 208 in some configurations of apparel 200. As with attachment elements 111-115, attachment elements 211-214 may be any of foam members, fluid-filled chambers (e.g., gas-filled or liquid-filled), plates, or electronic devices. Similarly, the shapes, sizes, and thicknesses of attachment elements 211-214 may vary. Accordingly, the configurations of attachment elements 211-214 may vary significantly.

[0026] Attachment elements 211-214 are secured to apparel 200 in a variety of different locations. As with apparel 100 and attachment elements 111-115, apparel 200 and attachment elements 211-214 each incorporate portions of a fastening system that is utilized to secure attachment elements 211-214 to outer surface 107. A variety of fastening systems may be utilized, including hook-and-loop fastening systems, magnetic fastening systems, adhesive fastening systems, and button-type fastening systems, for example. For purposes of reference, portions of apparel 200 and other elements incorporating the fastening system or a part of the fastening system are depicted as having a stippled or otherwise textured configuration in the figures.

[0027] In addition to attaching or otherwise securing attachment elements 211-214 to apparel 200, the fastening system permits attachment elements 211-214 to be detached or otherwise separated from apparel 200. Referring to Figure 5B, therefore, each of attachment elements 211-214 are depicted as being separated from apparel 200. Moreover, the fastening system also permits attachment elements 211-214 to be (a) repeatedly attached to and detached from apparel 200, (b) attached to apparel 200 in a variety of different locations, and (c) attached in a variety of different orientations. Referring to Figure 5C, therefore, each of attachment elements 211-214 are depicted as being re-attached to apparel 200 in different locations and with different orientations.

[0028] Any of the materials discussed above for apparel 100 may be utilized in manufacturing apparel 200.

Depending upon the specific fastening system that is utilized for attachment elements 211-214, apparel 200 may also incorporate elements related to the fastening system. For example, magnetic elements or buttons may be incorporated into the textile materials of apparel 200 when a magnetic fastening system or a button-type fastening system is utilized. As another example, elements of either a hook part or a loop part of a hook-and-loop fastening system may be secured to apparel 200 in order to form a portion of outer surface 207. Alternatively, the hook part or the loop part of the hook-and-loop fastening system may be knitted as an integral part of the textile material forming apparel 200.

[0029] Apparel 200 is depicted as having the configuration of a pants-type garment, particularly a pair of pants. In some configurations, apparel 200 may be intended for use as a compression garment that (a) exhibits a relatively tight fit that lays adjacent to the skin of the wearer and (b) stretches to conform with the contours of the wearer. Although the textile materials of apparel 200 may have one-directional stretch, the textile materials forming apparel 200 may have two-directional stretch of at least thirty percent prior to tensile failure.

[0030] Substantially all of outer surface 207 has a configuration that provides locations for securing attachment elements 211-214. That is, at least ninety percent of outer surface 207 provides locations for securing attachment elements 211-214. When, for example, the loop part of the hook-and-loop fastening system is knitted as an integral part of the textile material forming apparel 200, substantially all of outer surface 207 may be formed from the textile material. In some configurations, however, only portions of outer surface 207 may provide locations for securing attachment elements 211-214. That is, a part of the fastening system may be absent from portions of outer surface 207 or textile materials that do not provide locations for securing attachment elements 211-214 may be utilized for portions of outer surface 207.

[0031] Apparel 200 is depicted in a configuration wherein the fastening system is absent from a majority of leg regions 202 and 203 in Figure 6A. Given that portions of apparel 100 incorporating the fastening system or a part of the fastening system are depicted as having a stippled or otherwise textured configuration in the figures, areas without the stippled or otherwise textured configuration represent areas where the fastening system or a part of the fastening system is absent. Figure 6B depicts a configuration wherein the fastening system is absent from pelvic region 201, but forms at least seventy-five percent of outer surface 207. Additionally, a configuration wherein the fastening system is present in only selected areas of regions 201-203 is depicted in Figure 6C. Although apparel 200 is depicted as having the configuration of a pair of pants in each of Figures 4-6C, concepts associated with apparel 200 may also be incorporated into other pants-type garments. As an example, apparel 200 is depicted as having the configuration of a pair of shorts in Figure 6D, but may also be

briefs, jeans, or underwear. Furthermore, a shorts configuration wherein the fastening system is present in at least fifty percent of the outer surface is depicted in Figure 6E.

Attachment Element Configurations

[0032] Attachment elements 111-115 and 211-214 may exhibit a variety of different configurations, depending upon the activities, particular needs, and preferences of a wearer. As discussed above, attachment elements 111-115 and 211-214 may be (a) foam members, gas-filled chambers, or plates, (b) liquid-filled chambers, or (c) electronic devices, such as, mobile phones, portable music players, timing devices, locator beacons, global positioning systems, or mobile computing devices. Moreover, the shapes, sizes, and thicknesses, for example, of attachment elements 111-115 and 211-214 may vary significantly. In general, however, each of attachment elements 111-115 and 211-214 incorporate a part of the fastening system that permits attachment elements 111-115 and 211-214 to be (a) repeatedly attached to and detached from apparel 100 and apparel 200, (b) attached to apparel 100 and apparel 200 in a variety of different locations, and (c) attached in a variety of different orientations.

[0033] A more specific example of an attachment element 301 is depicted in Figures 7-9 as including a plurality of portions 302 that are joined by a fastening part 303. Portions 302 may be formed from a polymer foam material, for example, and are separated from each other by a plurality of incisions 304. Each of portions 302 may also include at least one aperture 305, which enhances breathability and reduces the overall weight of attachment element 301. Fastening part 303 is secured to each of portions 302 and generally incorporates a part of the fastening system that secures attachment element 301 to apparel 100 or apparel 200. When, for example, the textile material forming apparel 100 or apparel 200 incorporates the loop part of the hook-and-loop fastening system, fastening part 303 may incorporate the hook part of the hook-and-loop fastening system.

[0034] An advantage of incisions 304 is that the flex properties of attachment element 301 are enhanced. Referring to Figure 10, attachment element 301 is shown in a flexed configuration, wherein incisions 304 separate to provide flex grooves that permit attachment element to curve or otherwise bend. As discussed in greater detail below, flexing permits attachment element 301 to conform with the shape of apparel 100 or apparel 200 in the location where attachment element 301 is secured to either apparel 100 or apparel 200. Although incisions 304 may extend entirely through the polymer foam material of portions 302, incisions 304 may also extend partially (e.g., at least fifty percent) through the polymer foam material, as depicted in Figure 11A. Although incisions 304 may extend from an upper surface of portions 302 toward a lower surface, incisions 304 may also extend from the

lower surface toward the upper surface and through fastening part 303, as depicted in Figure 11B. Moreover, apertures 305 may also be absent from attachment element 301, as depicted in Figure 11B. In other configurations, incisions 304 may be absent, as depicted in Figure 11C, or portions 302 may impart a tapered configuration to attachment element 301.

[0035] As with attachment elements 111-115, attachment element 301 may be secured to apparel 100, detached from apparel 100, and subsequently re-attached to apparel 100. Referring to Figure 12, two of attachment element 301 are depicted as being secured to apparel 100. Whereas one of attachment elements 301 is in a complete state, the other of attachment elements 301 is separated into different sections and secured to different areas of apparel 100. In addition to providing flex, therefore, incisions 304 form separation lines where attachment element 301 may be divided into different sections. The wearer may, therefore, separate attachment element 301 into different sections in order to customize or otherwise tailor the shape and size of attachment element 301 to meet particular needs or purposes. Referring to Figure 13, one section of attachment element 301 is shown as being attached to apparel 100, particularly arm region 103. An incision 304 between two portions 302 permits the section of attachment element 301 to flex to conform with the curvature in arm region 103.

[0036] The polymer foam material forming portions 302 attenuate compression forces (i.e., impart padding or cushioning) to provide impact protection to areas of the wearer where attachment element 301 or sections of attachment element 301 are located. For example, if the wearer has an injury to a shoulder area, attachment element 301 may be secured to apparel 100 and placed over the shoulder area to provide protection to the shoulder area during athletic activities. Similarly, if the wearer has an injury in the abdomen area, attachment element 301 may be located to protect to the abdomen area. Accordingly, attachment element 301 or sections of attachment element 301 may be utilized to impart protection to specific areas of the wearer.

[0037] An example of another attachment element 311 is depicted in Figures 14 and 15 as including a plurality of portions 312 that are joined by a fastening part 313. Portions 312 may be formed from a polymer foam material, for example, and are separated from each other by a plurality of incisions 314. Each of portions 312 may also include at least one aperture 315. Fastening part 313 is secured to each of portions 312 and generally incorporates a part of the fastening system that secures attachment element 311 to apparel 100 or apparel 200. When, for example, the textile material forming apparel 100 or apparel 200 incorporates the loop part of the hook-and-loop fastening system, fastening part 313 may incorporate the hook part of the hook-and-loop fastening system. An advantage of incisions 314 is that the flex properties of attachment element 311 are enhanced.

[0038] As with attachment elements 211-214, attach-

ment element 311 may be secured to apparel 200, detached from apparel 200, and subsequently re-attached to apparel 200. Referring to Figure 16, two of attachment element 311 are depicted as being secured to apparel 200. Whereas one of attachment elements 311 is in a complete state, the other of attachment elements 311 is separated into different sections and secured to different areas of apparel 200. In addition to providing flex, therefore, incisions 314 form separation lines where attachment element 311 may be divided into different sections. The wearer may, therefore, separate attachment element 311 into different sections in order to customize or otherwise tailor the shape and size of attachment element 311 to meet particular needs or purposes. Referring to Figure 17, attachment element 311 is shown as being attached to apparel 200, particularly leg region 202. Incisions 314 permit attachment element 311 to flex to conform with the curvature in leg region 202. As with attachment element 301, attachment element 311 or sections of attachment element 311 may be utilized to impart protection to specific areas of the wearer.

[0039] Another example of an attachment element 321 is depicted in Figures 18 and 19 as having a plate 322 and a fastening part 323. Whereas portions 302 and 312 were discussed as being formed from polymer foam materials, plate 322 may be formed from nonfoamed polymer materials or rubber, for example. In some configurations, however, polymer foam materials may also be utilized for plate 322. Each of plate 322 and fastening part 323 may also define a plurality of apertures 325. As with the polymer foam materials of attachment elements 301 and 311, the plate configuration of attachment element 321 may be utilized to impart protection to specific areas of the wearer.

[0040] Yet another example of an attachment element 331 is depicted in Figures 20-22 as having a chamber portion 332 and a fastening part 333. Chamber portion 332 is formed from a polymer material that defines an interior void for receiving a fluid. Fastening part 333 is secured to chamber portion 332 and generally incorporates a part of the fastening system that secures attachment element 331 to apparel 100 or apparel 200. A plurality of indentations 334 are formed in a surface of chamber portion 332 to enhance the flexibility of attachment element 331. Either a gas or a liquid may be located within the void in chamber portion 332. In some configurations, chamber portion 332 may include an opening that permits the wearer to locate a liquid within chamber portion 332 or drain the liquid from chamber portion 332.

[0041] When chamber portion 332 includes a gas, such as a pressurized gas, attachment element 331 may be utilized to attenuate compression forces (i.e., impart padding or cushioning) to provide impact protection to areas of the wearer where attachment element 331 is located. That is, attachment element 331 may be utilized to impart protection to specific areas of the wearer. When a liquid is located within the void in chamber portion 332, the liquid may be utilized to impart heating or cooling to areas

of the wearer where attachment element 331 is located. More particularly, attachment element 331 and the liquid within attachment element 331 may be heated or cooled. Once located adjacent to a specific area of the wearer, attachment element 331 and the liquid within attachment element 331 may impart heat to or draw heat away from the area of the wearer.

[0042] A further example of an attachment element 341 is depicted in Figures 23 and 24 as having including an electronic device 342. A fastening part 343 is secured to a back surface of device 342 and generally incorporates a part of the fastening system that secures attachment element 341 to apparel 100 or apparel 200. As examples, electronic device 342 may be any of a mobile phone, portable music player, timing device, locator beacon, global positioning system, or mobile computing device.

Second Shirt-Type Garment Configuration

[0043] An article of apparel 400 having the configuration of a shirt-type garment is depicted in Figure 25. Apparel 400 includes a torso region 401 and a pair of arm regions 402 and 403 that extend outward from torso region 401. Torso region 401 corresponds with a torso of a wearer and covers at least a portion of the torso when worn. An upper area of torso region 401 defines a neck opening 404 through which the neck and head of the wearer protrude when apparel 400 is worn. Similarly, a lower area of torso region 401 defines a waist opening 405 through which the waist or pelvic area of the wearer protrudes when apparel 400 is worn. Arm region 402 corresponds with a right arm of the wearer and covers at least a portion of the right arm, and arm region 403 corresponds with a left arm of the wearer and covers at least a portion of the left arm. Each of arm regions 402 and 403 define a wrist opening 406 through which a hand and wrist of the wearer protrude when apparel 400 is worn.

[0044] Apparel 400 exhibits a two-layer configuration having an outer layer 407 and an adjacent inner layer 408 that extend through each of regions 401-403. Whereas outer layer 407 forms an outer portion of apparel 400, inner layer 408 forms an inner portion that may contact the wearer when apparel 400 is worn. A variety of attachment elements 411 are secured between layers 407 and 408. More particularly, attachment elements 411 are located between layers 407 and 408 in torso region 401 and in each of arm regions 402 and 403. Attachment elements

[0045] 411 may be any of foam members, fluid-filled chambers (e.g., gas-filled or liquid-filled), plates, or electronic devices. Although depicted as having a generally square aspect for purposes of example, the shapes, sizes, and thicknesses of attachment elements 411 may vary significantly.

[0046] Apparel 400 and attachment elements 411 each incorporate portions of a fastening system that is utilized to secure attachment elements 411 between layers 407 and 408. In addition to attaching or otherwise

securing attachment elements 411 to apparel 400, the fastening system permits attachment elements 411 to be detached or otherwise separated from apparel 400. As with apparel 100 and 200, a variety of fastening systems may be utilized, including hook-and-loop fastening systems, magnetic fastening systems, adhesive fastening systems, and button-type fastening systems, for example. For purposes of reference, portions of apparel 400 and attachment elements 411 incorporating the fastening system or a part of the fastening system are depicted as having a stippled or otherwise textured configuration in the figures. More particularly, and with reference to Figure 26, (a) surfaces of layers 407 and 408 that contact each other and (b) opposite surfaces of attachment elements 411 each include a part of the fastening system. That is, (a) an inwardly-facing surface of outer layer 407 includes a part of the fastening system, (b) an outwardly-facing surface of inner layer 408 includes a part of the fastening system, and (c) both surfaces of each attachment element 411 include a part of the fastening system. Accordingly, when one of attachment elements 411 is located between layers 407 and 408, as depicted in Figure 27, parts of the fastening system associated with facing surfaces of layers 407 and 408 each join with parts of the fastening system located on opposite sides of the attachment element 411.

[0047] Whereas only one surface of attachment elements 111-115, 211-214, 301, 311, 321, 331, and 341, incorporates a part of a fastening system that joins with an article of apparel, both surfaces of attachment elements 411 incorporate a part of a fastening system and join with apparel 400 (i.e., layers 407 and 408). Advantages to this configuration are that attachment elements 411 may be positively-secured to apparel 400 and are less likely to be inadvertently-removed from apparel 400. More particularly, securing both sides of attachment elements 411 to apparel 400 and between layers 407 and 408 reduces the probability that attachment elements 411 may be stripped from apparel 400 or will fall off of apparel 400. In configurations where attachment elements 411 incorporate a liquid-filled chamber, each of attachment elements 411 may be relatively heavy and may benefit from being secured on both surfaces. Accordingly, the two-layer configuration of apparel 400 imparts a configuration wherein attachment elements 411 are positively-secured and less likely to be inadvertently-removed from apparel 400.

[0048] For purposes of the following discussion, assume that the fastening system incorporated into apparel 400 and attachment elements 411 is a hook-and-loop fastening system. The hook part and the loop part of the hook-and-loop fastening system may be associated with various portions of apparel 400 and attachment elements 411. As examples, (a) each of layers 407 and 408 may incorporate the loop part, and the opposite surfaces of attachment elements 411 may incorporate the hook part; (b) each of layers 407 and 408 may incorporate the hook part, and the opposite surfaces of attachment elements

411 may incorporate the loop part; (c) layer 407 may incorporate the hook part, layer 408 may incorporate the loop part, and the opposite surfaces of attachment elements 411 may incorporate the hook part and the loop part; or (d) layer 407 may incorporate the loop part, layer 408 may incorporate the hook part, and the opposite surfaces of attachment elements 411 may incorporate the hook part and the loop part. Although any of the configurations discussed above may be utilized, an advantage to forming apparel 400 such that each of layers 407 and 408 incorporate the loop part or the hook part (i.e., examples (a) or (b)) is that layers 407 and 408 exhibit less of a tendency to join with each other.

[0049] Any of the materials discussed above for apparel 100 may be utilized in manufacturing apparel 400. When apparel 400 and attachment elements 411 incorporate a hook-and-loop fastening system, elements of either a hook part or a loop part may be secured to facing surfaces of layers 407 and 408, as well as opposite surfaces of attachment elements 411. Alternatively, the hook part or the loop part of the hook-and-loop fastening system may be knitted as an integral part of the textile material forming each of layers 407 and 408. In some configurations, the textile materials may include coatings that form a breathable and water-resistant barrier, or polymer sheets may be utilized in place of textile materials. Each of layers 407 and 408 may also be formed from laminated or otherwise layered materials that include two or more layers of textile materials, polymer sheets, or combinations of textile materials and polymer sheets.

[0050] Apparel 400 is depicted as having the configuration of a shirt-type garment, particularly a long-sleeved shirt. While apparel 400 may be intended to have a loose-fitting configuration, apparel 400 may also be intended for use as a compression garment. As discussed above, compression garments or other garments intended as base layers (a) exhibit a relatively tight fit that lays adjacent to the skin of the wearer and (b) stretch to conform with the contours of the wearer. While the textile materials forming compression garments may have one-directional stretch of, for example, more than ten percent prior to tensile failure, the textile materials forming other compression garments have two-directional stretch of at least thirty percent prior to tensile failure. Accordingly, when apparel 400 is formed to have a relatively tight fit and to stretch to conform with the contours of the wearer, the textile materials forming apparel 400 (i.e., layers 407 and 408) may have two-directional stretch of at least thirty percent prior to tensile failure. In some configurations, outer layer 407 may impart a loose-fitting configuration, whereas inner layer 408 may provide a relatively tight and stretchable fit. In other configurations, inner layer 408 may impart a loose-fitting configuration, whereas outer layer 407 may provide a relatively tight and stretchable fit.

[0051] Each of outer layer 407 and inner layer 408 extend through substantially all of regions 401-403, which permits attachment elements 411 to be secured to any

area of regions 401-403. In some configurations, only a portion of layers 407 and 408 may incorporate a part of the fastening system. For example, although layers 407 and 408 may extend through substantially all of regions 401-403, the fastening system may be absent from torso region 401 or may alternately be absent from arm regions 402 and 403. In other configurations, layers 407 and 408 may cover different areas of the wearer. As an example, a configuration wherein inner layer 408 is limited to an upper area of torso region 401 and upper areas of arm regions 402 and 403 is depicted in Figure 28A. In this configuration, the fastening system is present in at least fifty percent of apparel 400. Inner layer 408 may also be absent from arm regions 402 and 403, as depicted in Figure 28B. A configuration wherein inner layer 408 is only located in arm regions 402 and 403 is illustrated in Figure 28C. In this configuration, the fastening system is present in at least twenty percent of apparel 400. Moreover, Figure 28D depicts a configuration wherein (a) outer layer 407 is absent in lower portions of arm regions 402 and 403, whereas inner layer 408 extends through each or regions 401-403. Although apparel 400 is depicted as having the configuration of a long-sleeved shirt in each of Figures 25-28D, concepts associated with apparel 400 may also be incorporated into other shirt-type garments, including a short-sleeved shirt, a tank top, undershirt, jacket, or coat. Accordingly, the relative areas covered by the fastening system and layers 407 and 408 may vary significantly.

Second Pants-Type Garment Configuration

[0052] Various concepts associated with apparel 400 may also be incorporated into other types of apparel. An article of apparel 500 having the configuration of a pants-type garment is depicted in Figures 29 and 30. Apparel 500 includes a pelvic region 501 and a pair of leg regions 502 and 503 that extend outward from pelvic region 501. As with apparel 400, apparel 500 has a two-layer configuration that includes an outer layer 507 and an adjacent inner layer 508 that extend through each of regions 501-503. Whereas outer layer 507 forms an outer portion of apparel 500, inner layer 508 forms an inner portion that may contact the wearer when apparel 500 is worn. Any of the materials discussed above may be utilized in manufacturing apparel 500. A variety of attachment elements 511 are secured between layers 507 and 508, as depicted in Figure 31. Attachment elements 511 may be any of foam members, fluid-filled chambers (e.g., gas-filled or liquid-filled), plates, or electronic devices. Although depicted as having a generally square aspect for purposes of example, the shapes, sizes, and thicknesses of attachment elements 511 may vary significantly.

[0053] Apparel 500 and attachment elements 511 each incorporate portions of a fastening system that is utilized to secure attachment elements 511 between layers 507 and 508. In addition to attaching or otherwise securing attachment elements 511 to apparel 500, the

fastening system permits attachment elements 511 to be detached or otherwise separated from apparel 500. A variety of fastening systems may be utilized, including hook-and-loop fastening systems, magnetic fastening systems, adhesive fastening systems, and button-type fastening systems, for example. When incorporating the hook-and-loop fastening system, an advantage to forming apparel 500 such that each of layers 507 and 508 incorporate the loop part or the hook part is that layers 507 and 508 exhibit less of a tendency to join with each other. For purposes of reference, portions of apparel 500 and attachment elements 511 incorporating the fastening system or a part of the fastening system are depicted as having a stippled or otherwise textured configuration in the figures.

[0054] While apparel 500 may be intended to have a loose-fitting configuration, apparel 500 may also be intended for use as a compression garment. As discussed above, compression garments or other garments intended as base layers (a) exhibit a relatively tight fit that lays adjacent to the skin of the wearer and (b) stretch to conform with the contours of the wearer. While the textile materials forming compression garments may have one-directional stretch of, for example, more than ten percent prior to tensile failure, the textile materials forming other compression garments have two-directional stretch of at least thirty percent prior to tensile failure. Accordingly, when apparel 500 is formed to have a relatively tight fit and to stretch to conform with the contours of the wearer, the textile materials forming apparel 500 (i.e., layers 507 and 508) may have two-directional stretch of at least thirty percent prior to tensile failure. In some configurations, outer layer 507 may impart a loose-fitting configuration, whereas inner layer 508 may provide a relatively tight and stretchable fit. In other configurations, inner layer 508 may impart a loose-fitting configuration, whereas outer layer 507 may provide a relatively tight and stretchable fit

[0055] Each of outer layer 507 and inner layer 508 extend through substantially all of regions 501-503, which permits attachment elements 511 to be secured to any area of regions 501-503. In some configurations, only a portion of layers 507 and 508 may incorporate a part of the fastening system. For example, although layers 507 and 508 may extend through substantially all of regions 501-503, the fastening system may be absent from pelvic region 501 or may alternately be absent from leg regions 502 and 503. In other configurations, layers 507 and 508 may cover different areas of the wearer. As an example, a configuration wherein inner layer 508 is limited to pelvic region 501 is depicted in Figure 32A. In this configuration, the fastening system is present in at least fifty percent of apparel 400. Inner layer 508 may also be absent from pelvic region 501, as depicted in Figure 32B. A configuration wherein inner layer 508 is only located in side areas of apparel 500 is illustrated in Figure 32C. In this configuration, the fastening system is present in at least twenty percent of apparel 400. Although apparel 500 is depicted

as having the configuration of a pair of shorts in each of Figures 29-32C, concepts associated with apparel 500 may also be incorporated into a pair of pants, as in Figure 32D, or into briefs, jeans, and underwear. Accordingly, the relative areas covered by the fastening system and layers 507 and 508 may vary significantly.

Further Attachment Element Configurations

[0056] Attachment elements 411 and 511 may exhibit a variety of different configurations, depending upon the activities, particular needs, and preferences of a wearer. An example of an attachment element 601 is depicted in Figures 33-35 as including a plurality of portions 602 that are separated from each other by a plurality of incisions 604. A pair of fastening parts 603a and 603b are secured to opposite sides of portions 602. Whereas incisions 604 extend through fastening part 603a, fastening part 603b extends across incisions 604. Fastening parts 603a and 603b incorporate a part of the fastening system that secures attachment element 601 to apparel 400 or apparel 500. That is, fastening parts 603a and 603b are located on opposite surfaces of portions 602 and join with facing surfaces of layers 407 and 408 or 507 and 508. When, for example, the textile material forming apparel 400 or apparel 500 incorporates the loop part of the hook-and-loop fastening system, fastening parts 603a and 603b may incorporate the hook part of the hook-and-loop fastening system. An advantage of incisions 604 is that the flex properties of attachment element 601 are enhanced, as depicted in Figure 36. In general, therefore, attachment element 601 is similar to attachment element 301, but includes an additional part of the fastening system on an opposite surface.

[0057] Another example of an attachment element 611 is depicted in Figures 37 and 38 as having a plate (not depicted) that is located between two fastening parts 613a and 613b. Fastening parts 613a and 613b are located on opposite surfaces of the plate and join with facing surfaces of layers 407 and 408 or 507 and 508. In general, therefore, attachment element 611 is similar to attachment element 321, but includes an additional part of the fastening system on an opposite surface.

[0058] Yet another example of an attachment element 621 is depicted in Figures 39-41 as having a chamber portion 622 located between two fastening parts 623a and 623b. Chamber portion 622 is formed from a polymer material that defines an interior void for receiving a fluid. Either a gas or a liquid may be located within the void in chamber portion 622. In some configurations, chamber portion 622 may include an opening that permits the wearer to locate a liquid within chamber portion 622 or drain the liquid from chamber portion 622. Fastening parts 623a and 623b are located on opposite surfaces of chamber portion 622 and join with facing surfaces of layers 407 and 408 or 507 and 508. In general, therefore, attachment element 621 is similar to attachment element 331, but includes an additional part of the fastening sys-

tem on an opposite surface.

[0059] Turning now to FIG. 42, a perspective view of an exemplary article 700 is depicted. The exemplary article 700 is generally referred to as having attachment elements or modular elements which, in accordance with aspects herein, means that the modular elements are separable from one another to allow a wearer to customize the protective padding which they are wearing. In order to allow for the elements to be modular, the exemplary article 700 includes an incision pattern 728 which defines a plurality of attachment elements 701 which are selectively detachable.

[0060] As shown in FIGs. 42 and 43, the exemplary article 700 is generally comprised of a textile layer 702, a cushion layer 706, and an attachment layer 710, although articles having additional layers of textile, cushioning or attachment mechanisms are considered to be within the scope of this disclosure. In accordance with aspects herein, the textile layer 702 may be made from natural yarns or fibers such as cotton, wool, silk and the like, or man-made yarns or fibers such as polyester, nylon, elastomeric yarns, and the like. The textile layer 702 may be woven, knitted, non-woven, braided, and the like. Further, the textile layer 702 may be formed of a mesh material for increased permeability and/or breathability, from a moisture-wicking material, and the like. Further, in accordance with aspects herein, the cushion layer 706 generally provides attenuation of impact forces that an athlete may experience when playing sports. For example, the cushion layer 706 may have a constant or linearly increasing or decreasing attenuation coefficient. Examples of materials which may be used in the cushion layer 706 includes foam rubbers, elastics, or molded plastics. The attachment layer 710 may include either a hook component or a loop component of a hook-and-loop attachment system. In accordance with aspects herein, the loop component of the hook-and-loop attachment system may be integrally formed from the attachment layer 710. Further, the loop component of the hook-and-loop attachment system may comprise 10 to 50 percent of the attachment layer 710.

[0061] Referring specifically to FIG. 43, a side view of the exemplary article 700 shown in FIG. 42 is depicted. In FIG. 43, the textile layer 702 is depicted as having a first surface 704a and a second surface 704b opposite the first surface 704a, the cushion layer 706 is depicted as having a third surface 708a and a fourth surface 708b opposite the third surface 708a, and the attachment layer 710 is depicted as having a fifth surface 712a and a sixth surface 712b opposite the fifth surface 712a. In accordance with aspects herein, a "textile layer thickness" 702t is defined as the distance between the first surface 704a and 704b, a "cushion layer thickness" 706t is defined as the distance between the third surface 708a and the fourth surface 708b, and an "attachment layer thickness" 710t is defined as the distance between the fifth surface 712a and the sixth surface 712b. The ratios between the textile layer thickness 702t, the cushion layer thickness

706t, and the attachment layer thickness 710t are variable. For example, the ratio between the textile layer thickness 702t and the cushion layer thickness 706t may be between 1:1 and 1:10, while the ratio between the cushion layer thickness 706t and the attachment layer thickness 710t may be between 10:1 and 1:1. However, the aforementioned ratios are not considered to be exhaustive; instead, it is contemplated that other ratios between the textile layer thickness 702t, the cushion layer thickness 706t, and the attachment layer thickness 710t are considered to be within the scope of this disclosure.

[0062] Returning to FIG. 42, the exemplary article 700 includes a first set of incisions 720 extending entirely through the textile layer 702, the cushion layer 706, and the attachment layer 710, from the first surface 704a of the textile layer 702 through the sixth surface 712b of the cushion layer 706. Additionally, the exemplary article 700 includes a second set of incisions 722 that are sized and shaped similarly to the first incisions 720, and that extend entirely through the textile layer 702, the cushion layer 706 and the attachment layer 710, from the first surface 704a through the sixth surface 712b.

[0063] Turning now to FIG. 44, and in accordance with aspects herein, the first set of incisions 720 and the second set of incisions 722 may together (in addition to, for example, additional sets of incisions) form at least part of the incision pattern 728. This incision pattern 728 may either partially or fully define the plurality of attachment elements 701. These attachment elements 701 are generally described as any portion of the exemplary article 700 which may be separated from the exemplary article 700. The incision pattern 728 depicted in FIG. 44 is merely exemplary, and any shape of incision pattern may be present in the exemplary article 700, such that the desired shape of each individual attachment element 701 may be achieved. For example, and as seen in FIG. 44, the elliptical portion shown as being detached from the exemplary article 700 is generally referred to as an attachment element 701. However, non-elliptical shapes of attachment elements 701 are considered to be within the scope of this disclosure. More specifically, non-rounded shapes (*i.e.*, square or rectangular) of attachment elements 701 are envisioned to be within the scope of this disclosure.

[0064] The incision pattern 728 may further comprise a third set of incisions 724 and a fourth set of incisions 726, wherein the third set of incisions 724 and the fourth set of incisions 726 define a rounded shape. Additionally, the first set of incisions 720 and the second set of incisions 722 may intersect with at least the third set of incisions 724. In yet another aspect, a fifth set of incisions 729 may be positioned in a central region of the article 700, where the fifth set of incisions 729 define a rounded shape.

[0065] The plurality of attachment elements 701 may also be partially defined by the incision pattern 728 when incisions extend only partially through the exemplary article 700. For example, if the incision pattern 728 com-

prised continuous, linear incisions without any breaks, there would not be anything that would hold the plurality of attachment elements 701 together. To help prevent this, the incision pattern 728 may comprise a discontinuous pattern where individual incisions are separated or spaced apart by connecting portions 732 in a dash-like pattern. In other words, the connecting portions 732 may separate or space apart the ends of first and second collinear incisions 725a, where the connecting portion 732 comprises only a portion of the textile layer 702 and not the cushion layer 706 or the attachment layer 710. In exemplary aspects, it is envisioned that the connecting portions 732 of the exemplary article 700 may account for up to 10 percent of the total length of the incision pattern 728 where the incision pattern 728 may be thought of as comprising both incisions such as the first and second set of incisions 722 and 724, the first and second collinear incisions 725a, and the connecting portions 732. In other words, the incision pattern 728 may comprise linear segments of incisions separated by the connecting portions 732, where the connecting portions 732 are co-linear with the incisions.

[0066] Turning now to FIG. 45, an attachment element 701 is depicted as being removed from the exemplary article 700 (not depicted in FIG. 45). As illustrated in FIG. 45, the incision pattern 728 has portions which extend completely through the attachment element 701, and portions which do not extend completely through the attachment element (i.e., the connecting portions 732). In other words, the connecting portions 732 are represented in white as the spaces between ends of co-linear incisions.

[0067] This concept is further illustrated by FIG. 46, which depicts a cross section of the attachment element 701 as seen in FIG. 45. FIG. 46 illustrates that the incision pattern 728 comprises incisions that extend completely through the attachment element 701 (shown on the far left and the far right). To put it another way, the collinear incisions 725a extend completely through the attachment element 701 from the textile layer 702 to the attachment layer 710. To form the connecting portions 732, a different set of incisions may be formed that extend only through the cushion layer 706 and the attachment layer 710 but not through the textile layer 702. These incisions are indicated by reference numeral 725b in FIG. 46. As described above, the connecting portions 732 help to maintain the structural integrity of the individual attachment elements 701 within the article 700 prior to the attachment elements 701 being detached by a user. In other words, the connecting portions 732 cover the incisions 725b which only extend through the cushion layer 706 and the attachment layer 710.

[0068] Turning now to FIGS. 47 and 48, individual elements of the plurality of attachment elements 701 are depicted as being attached to a lower body garment 800 and an upper body garment 802, respectively. In accordance with aspects herein, the lower body garment 800 may cover a wearer's full leg, from the thigh region to the ankle region, or the lower body garment 800 may cover

only a portion of the wearer's full leg, similar to football pants. Additionally, the upper body garment 802 may fully or partially cover a wearer's arms. The upper and lower body garments may have either a hook component or a loop component of a hook-and-loop system on an outer-facing surface of the garment. Then, each of the individual elements of the plurality of attachment elements 701 may be attached to the garment 800/802 via the opposing type of hook-and-loop attachment mechanism. In other words, the configuration of the hook-and-loop attachment mechanism means that the wearer of the plurality of attachment elements 701 would wear the opposing type of hook-and-loop attachment mechanism. The opposing type of hook-and-loop attachment mechanism may be formed into an upper or lower body article of apparel, and may comprise the entire surface of the upper or lower body article of apparel, or may comprise only a portion of the surface of the upper or lower body article of apparel.

[0069] Additionally, FIGS. 47 and 48 depict the modularity of the exemplary article 700. For example, a wearer of the lower body garment 800 or the upper body garment 802 may choose specific attachment elements 701 from the exemplary article 700. In this manner, the wearer of the lower body garment 800 or the upper body garment 802 may choose some or all of the plurality of attachment elements 701 that the wearer desires. Then the wearer may choose at what locations on the lower body garment 800 or the upper body garment 802 that the attachment elements 701 may be placed. In some configurations, the wearer of the lower body garment 800 or the upper body garment 802 may choose the smaller attachment elements to be placed towards the distal ends of the lower body garment 800 and upper body garment 802. In other configurations, the wearer of the lower body garment 800 or the upper body garment 802 may choose the larger attachment elements to be placed towards the distal ends of the lower body garment 800 and the upper body garment 802. In other words, the wearer may customize the amount of padding desired at certain locations of the lower body garment 800 and the upper body garment 802. Additionally, as depicted in FIGS. 47 and 48, the plurality of attachment elements 701 may be attached to either an inner layer of the garment (as depicted in FIG. 47), or to an outer layer of the garment (as seen in FIG. 48).

[0070] The invention is disclosed above and in the accompanying figures with reference to a variety of configurations. The purpose served by the disclosure, however, is to provide an example of the various features and concepts related to the invention, not to limit the scope of the invention. One skilled in the relevant art will recognize that numerous variations and modifications may be made to the configurations described above without departing from the scope of the present invention, as defined by the appended claims.

[0071] It will be understood that certain features and subcombinations are of utility and may be employed without reference to other features and subcombinations.

This is contemplated by and is within the scope of the claims.

[0072] Since many possible embodiments may be made of the invention without departing from the scope thereof, as defined by the claims, it is to be understood that all matter herein set forth or shown in the accompanying drawings is to be interpreted as illustrative and not in a limiting sense.

Claims

1. A pad comprising:

a cushion layer (706) having a first surface, a second surface, and a cushion-layer thickness (706t) between the first surface and the second surface;

an attachment layer (710) having a third surface, a fourth surface, and an attachment-layer thickness (710t) between the third surface and the fourth surface,

wherein the attachment layer (710) includes either a hook component or a loop component of a hook-and-loop attachment system, and

wherein the third surface of the attachment layer (710) is coupled to the second surface of the cushion layer (706);

a first incision (720) extending entirely through the cushion layer (706) and the attachment layer (710), from the first surface to the fourth surface; a second incision (722) that is collinear with the first incision (720) and that extends entirely through the cushion layer (706) and the attachment layer (710), from the first surface to the fourth surface; **characterized by**

a connecting portion (732) separating an end of the first incision (720) from an end of the second incision (722), the connecting portion (732) including a portion of the cushion layer (706) and a portion of the attachment layer (710).

2. The pad of claim 1, wherein the first incision (720) and the second incision (722) form at least part of an incision pattern (728).

3. The pad of claim 2, wherein the incision pattern fully defines a plurality of one or more attachment elements.

4. The pad of claim 2, wherein the incision pattern partially defines a plurality of one or more attachment elements.

5. The pad of claim 2, wherein the incision pattern fur-

ther comprises a third incision (724) and a fourth incision (726), wherein the third incision (724) and the fourth incision (726) have a rounded shape.

6. The pad of claim 5, wherein the first incision (720) and the second incision (722) intersect with at least the third incision.

7. The pad of claim 5 further comprising a fifth incision positioned in a central region of the pad, wherein the fifth incision (729) has a rounded shape.

8. The pad of claim 2, wherein the incision pattern (728) extends throughout an entirety of the pad.

9. The pad of claim 1, wherein a ratio between a length of the first incision (720) and a length of the connecting portion (732) is between 1 to 1 and 10 to 1.

10. The pad of claim 1, wherein a length of the connecting portion (732) is less than 5.08 cm (2 inches).

11. The pad of claim 1, wherein a ratio between the cushion-layer thickness (706t) and the attachment-layer thickness (710t) is between 10:1 and 1:1.

Patentansprüche

1. Pad, aufweisend:

eine Polsterschicht (706) mit einer ersten Oberfläche, einer zweiten Oberfläche und einer Polsterschichtdicke (706t) zwischen der ersten Oberfläche und der zweiten Oberfläche, eine Befestigungsschicht (710) mit einer dritten Oberfläche, einer vierten Oberfläche und einer Befestigungsschichtdicke (710t) zwischen der dritten Oberfläche und der vierten Oberfläche,

wobei die Befestigungsschicht (710) entweder eine Hakenkomponente oder eine Schlaufenkomponente eines Klettverschlussystems beinhaltet, und wobei die dritte Oberfläche der Befestigungsschicht (710) an die zweite Oberfläche der Polsterschicht (706) gekoppelt ist;

einen ersten Einschnitt (720), der sich vollständig durch die Polsterschicht (706) und die Befestigungsschicht (710) von der ersten Oberfläche zur vierten Oberfläche erstreckt; einen zweiten Einschnitt (722), der mit dem ersten Einschnitt (720) kollinear ist und der sich vollständig durch die Polsterschicht (706) und die Befestigungsschicht (710) von der ersten Oberfläche zur vierten Oberfläche erstreckt;

gekennzeichnet durch

- einen Verbindungsabschnitt (732), der ein Ende des ersten Einschnitts (720) von einem Ende des zweiten Einschnitts (722) trennt, wobei der Verbindungsabschnitt (732) einen Abschnitt der Polsterschicht (706) und einen Abschnitt der Befestigungsschicht (710) beinhaltet.
- 5
2. Pad nach Anspruch 1, wobei der erste Einschnitt (720) und der zweite Einschnitt (722) mindestens einen Teil eines Einschnittmusters (728) bilden.
- 10
3. Pad nach Anspruch 2, wobei das Einschnittmuster mehrere von einem oder mehr Befestigungselementen vollständig definiert.
- 15
4. Pad nach Anspruch 2, wobei das Einschnittmuster mehrere von einem oder mehr Befestigungselementen teilweise definiert.
- 20
5. Pad nach Anspruch 2, wobei das Einschnittmuster ferner einen dritten Einschnitt (724) und einen vierten Einschnitt (726) aufweist, wobei der dritte Einschnitt (724) und der vierte Einschnitt (726) eine rundliche Form haben.
- 25
6. Pad nach Anspruch 5, wobei sich der erste Einschnitt (720) und der zweite Einschnitt (722) mit mindestens dem dritten Einschnitt überschneiden.
- 30
7. Pad nach Anspruch 5, ferner aufweisend einen fünften Einschnitt, der in einem mittleren Bereich des Pads positioniert ist, wobei der fünfte Einschnitt (729) eine rundliche Form hat.
- 35
8. Pad nach Anspruch 2, wobei sich das Einschnittmuster (728) über das gesamte Pad erstreckt.
- 40
9. Pad nach Anspruch 1, wobei ein Verhältnis zwischen der Länge des ersten Einschnitts (720) und einer Länge des Verbindungsabschnitts (732) zwischen 1 zu 1 und 10 zu 1 liegt.
- 45
10. Pad nach Anspruch 1, wobei eine Länge des Verbindungsabschnitts (732) weniger als 5,08 cm (2 Zoll) beträgt.
- 50
11. Pad nach Anspruch 1, wobei ein Verhältnis zwischen der Polsterschichtdicke (706t) und der Befestigungsschichtdicke (710t) zwischen 10:1 und 1:1 liegt.
- 55
- Revendications**
1. Rembourrage comprenant :
- une couche de coussin (706) ayant une première surface, une deuxième surface et une épaisseur (706t) de couche de coussin entre la première surface et la deuxième surface ;
une couche de fixation (710) ayant une troisième surface, une quatrième surface et une certaine épaisseur (710t) de couche de fixation entre la troisième surface et la quatrième surface,
- la couche de fixation (710) comprenant soit un élément crochet, soit un élément boucle d'un système de fixation à boucles et à crochets, et
la troisième surface de la couche de fixation (710) étant accouplée à la deuxième surface de la couche de coussin (706) ;
une première incision (720) s'étendant entièrement à travers la couche de coussin (706) et la couche de fixation (710), de la première surface à la quatrième surface ;
une deuxième incision (722) colinéaire à la première incision (720) et s'étendant entièrement à travers la couche de coussin (706) et la couche de fixation (710), de la première surface à la quatrième surface ;
- caractérisé par :**
une partie de liaison (732) séparant une extrémité de la première incision (720) d'une extrémité de la deuxième incision (722), la partie de liaison (732) comprenant une partie de la couche de coussin (706) et une partie de la couche de fixation (710).
2. Le rembourrage de la revendication 1, dans lequel la première incision (720) et la deuxième incision (722) constituant au moins partie d'un motif d'incision (728).
3. Le rembourrage de la revendication 2, dans lequel le motif d'incision définit entièrement une pluralité d'un ou plusieurs éléments de fixation.
4. Le rembourrage de la revendication 2, dans lequel le motif d'incision définit partiellement une pluralité d'un ou plusieurs éléments de fixation.
5. Le rembourrage de la revendication 2, dans lequel le motif d'incision comprend en outre une troisième incision (724) et une quatrième incision (726), la troisième incision (724) et la quatrième incision (726) présentant une forme arrondie.
6. Le rembourrage de la revendication 5, dans lequel la première incision (720) et la deuxième incision (722) croisent au moins la troisième incision.
7. Le rembourrage de la revendication 5, comprenant en outre une cinquième incision positionnée dans une région centrale du rembourrage, la cinquième incision (729) présentant une forme arrondie.

8. Le rembourrage de la revendication 2, dans lequel le motif d'incision (728) s'étend à travers une intégralité du rembourrage.
9. Le rembourrage de la revendication 1, dans lequel un rapport entre une longueur de la première incision (720) et une longueur de la partie de liaison (732) est compris entre 1 à 1 et 10 à 1. 5
10. Le rembourrage de la revendication 1, dans lequel une longueur de la partie de liaison (732) est inférieure à 5,08 cm (2 pouces). 10
11. Le rembourrage de la revendication 1, dans lequel un rapport entre l'épaisseur (706t) de la couche de coussin et l'épaisseur (710t) de la couche de fixation est compris entre 10:1 et 1:1. 15

20

25

30

35

40

45

50

55

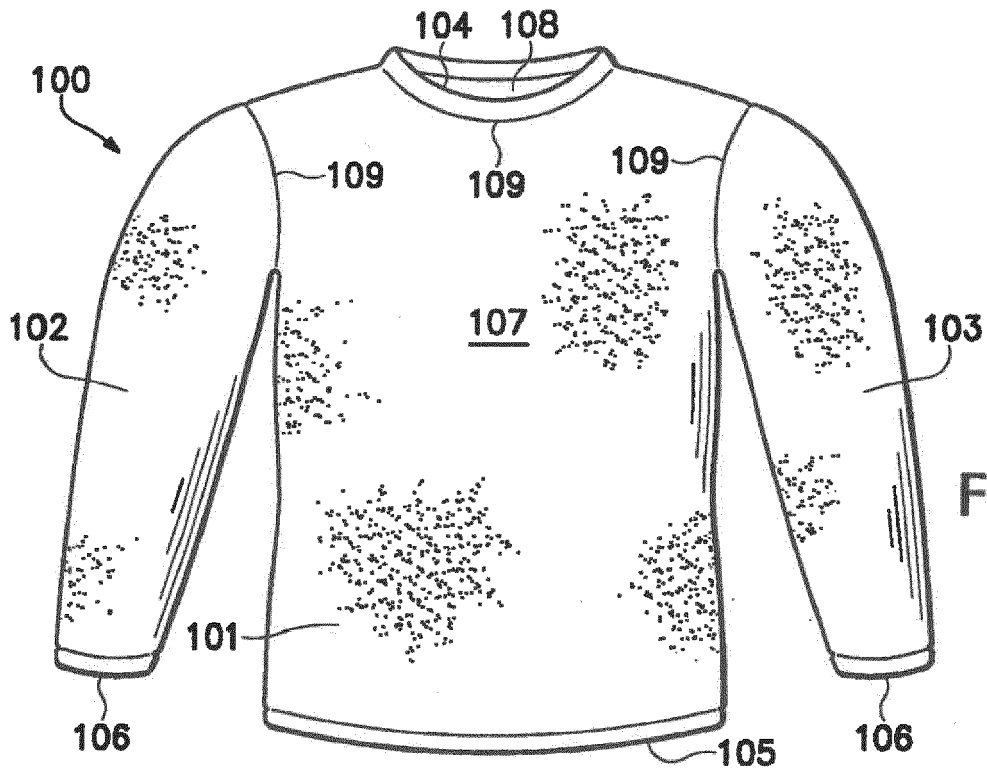

Figure 1

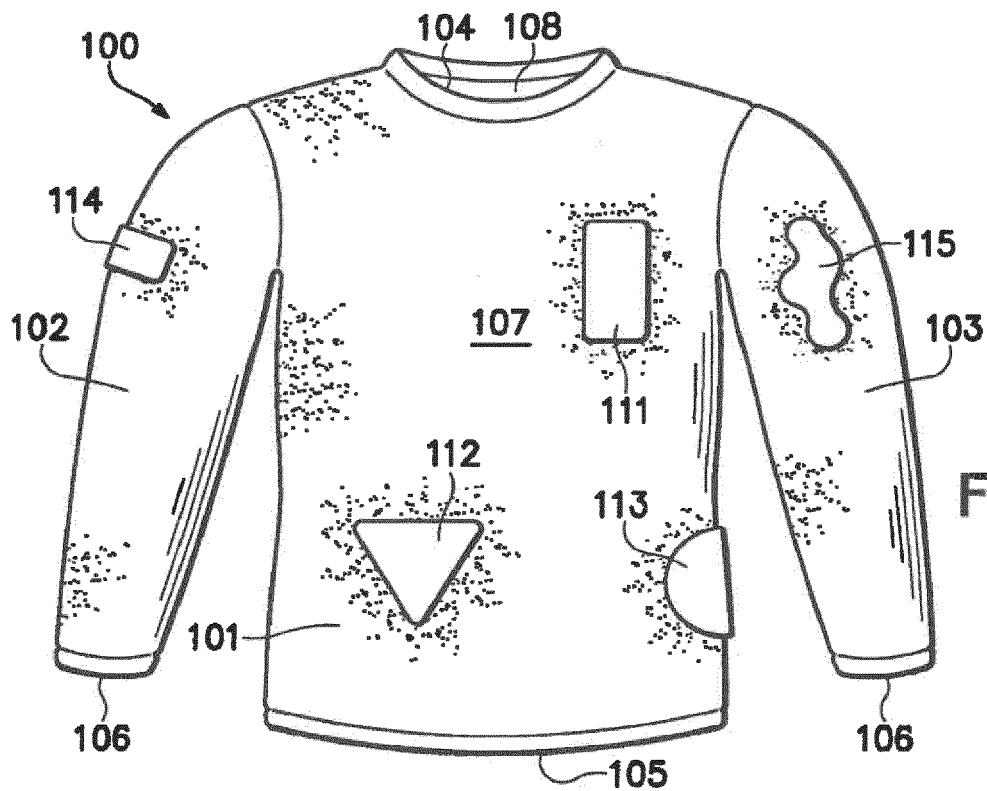

Figure 2A

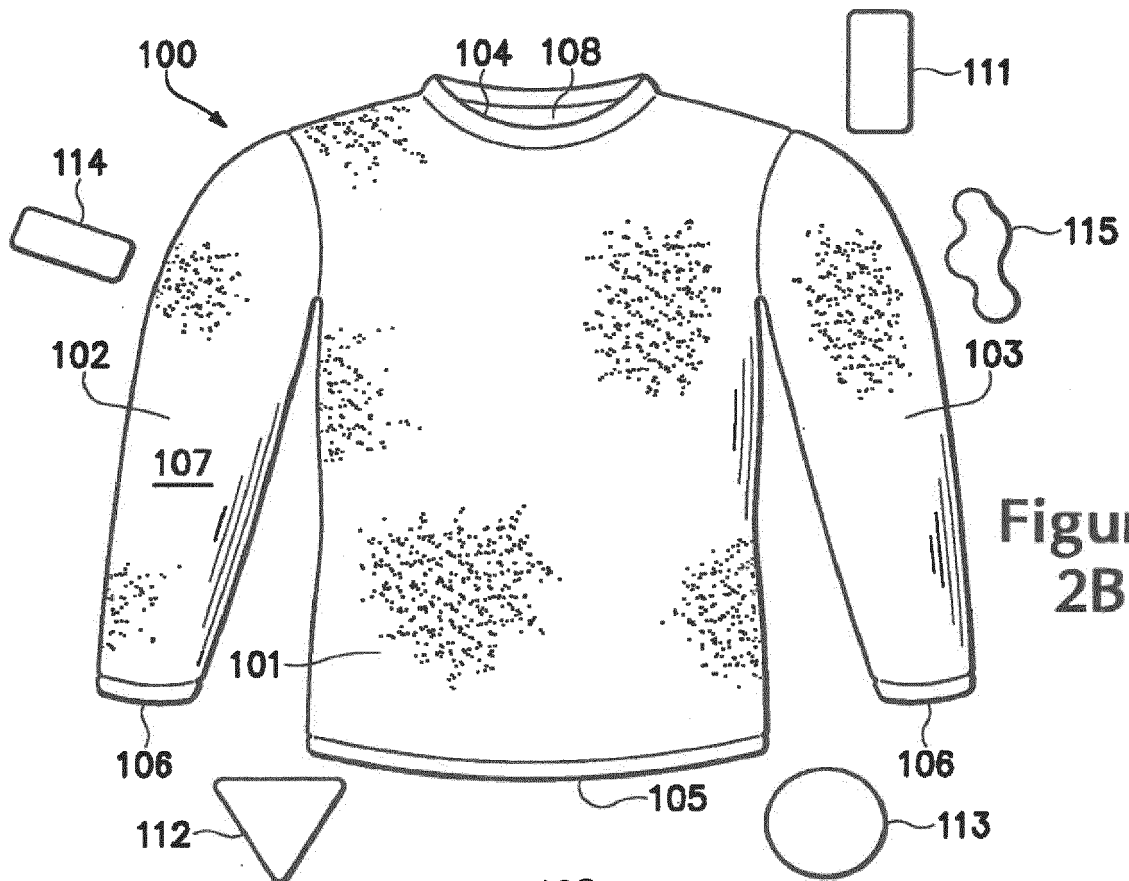

Figure 2B

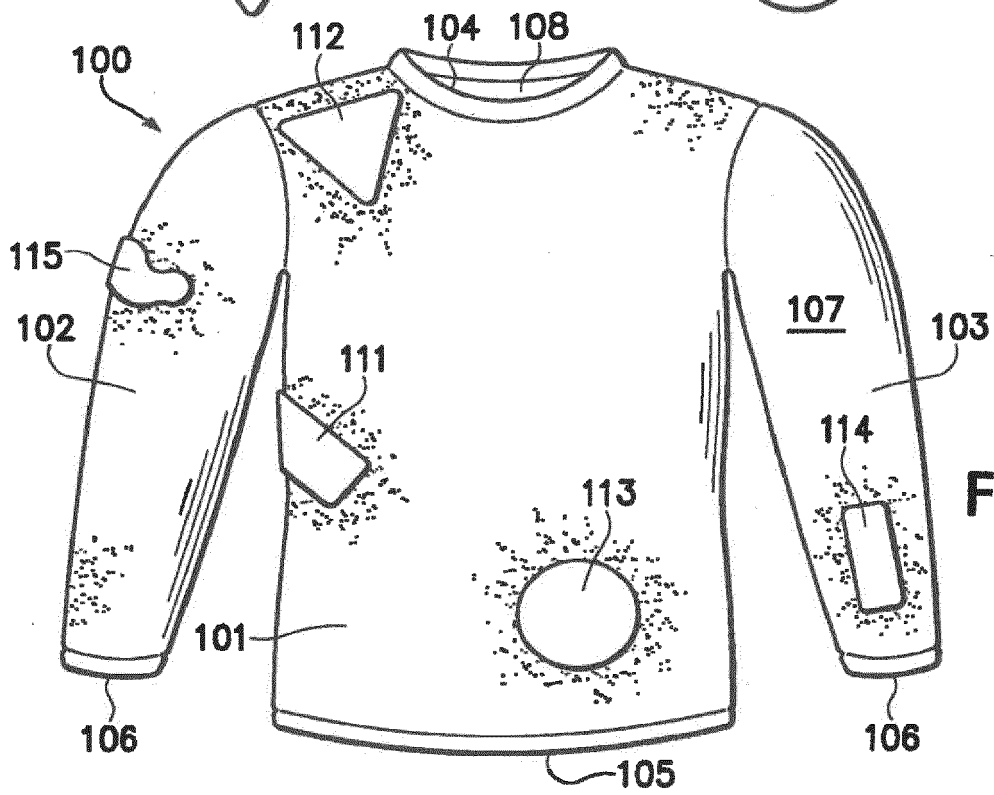

Figure 2C

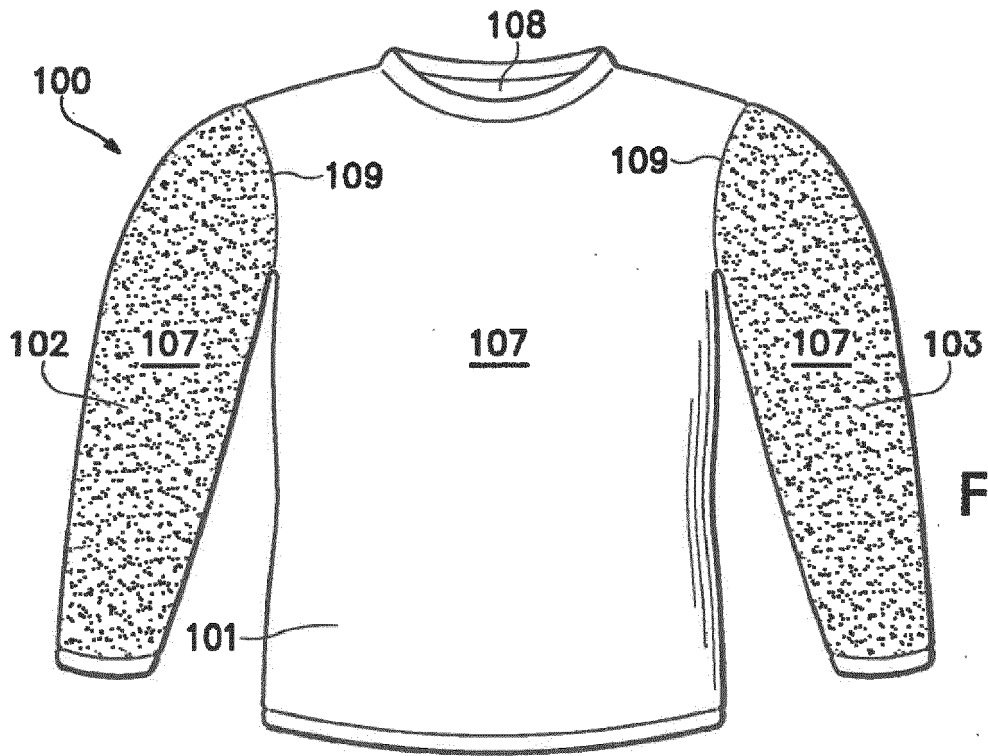

Figure 3A

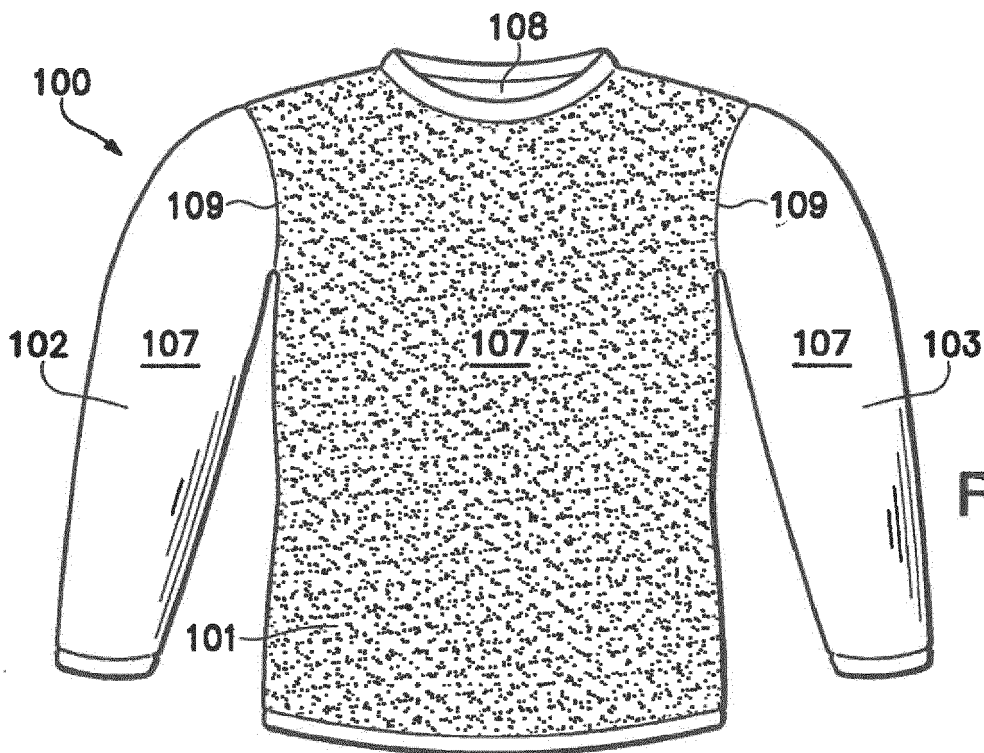

Figure 3B

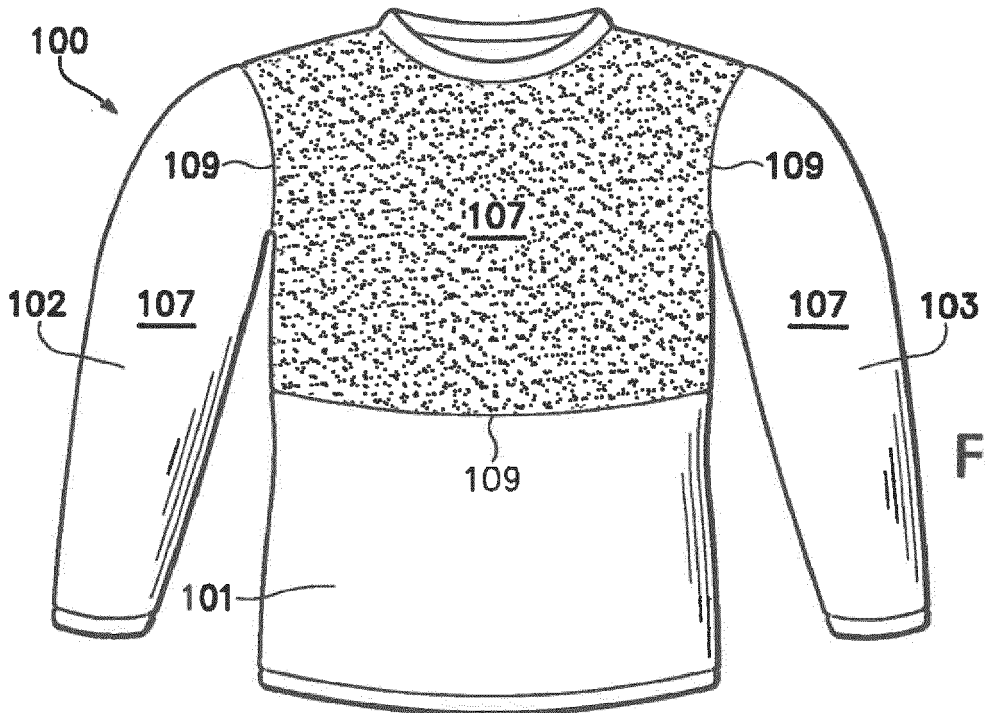

Figure
3C

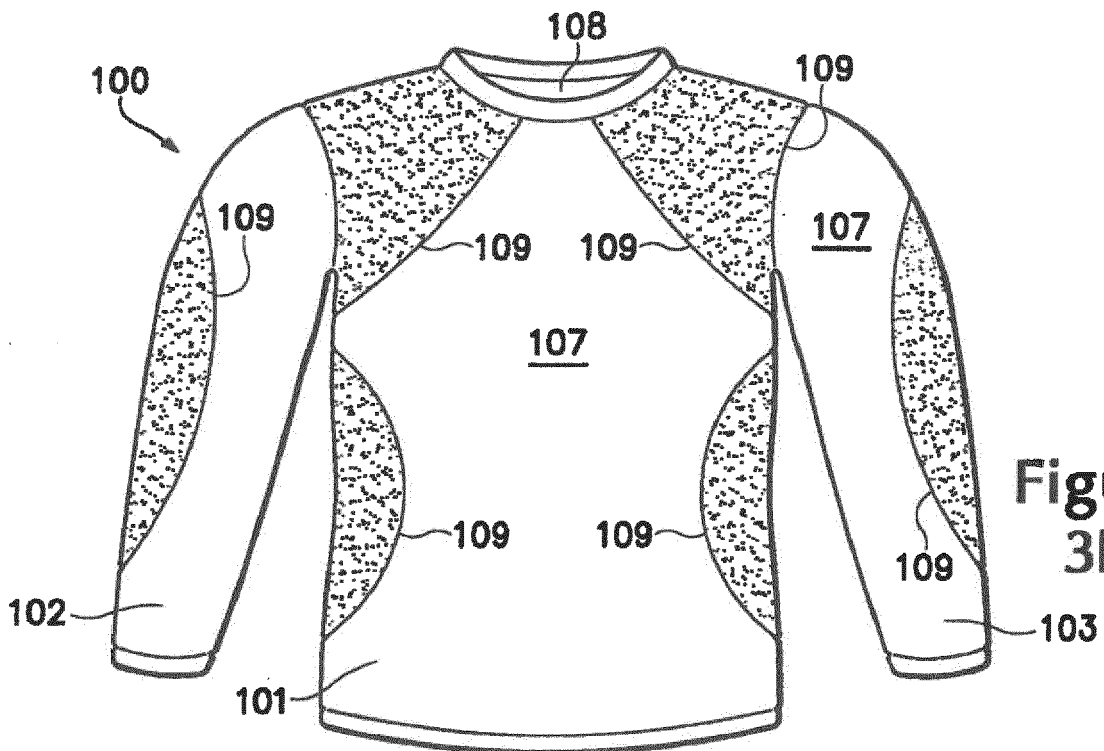

Figure
3D

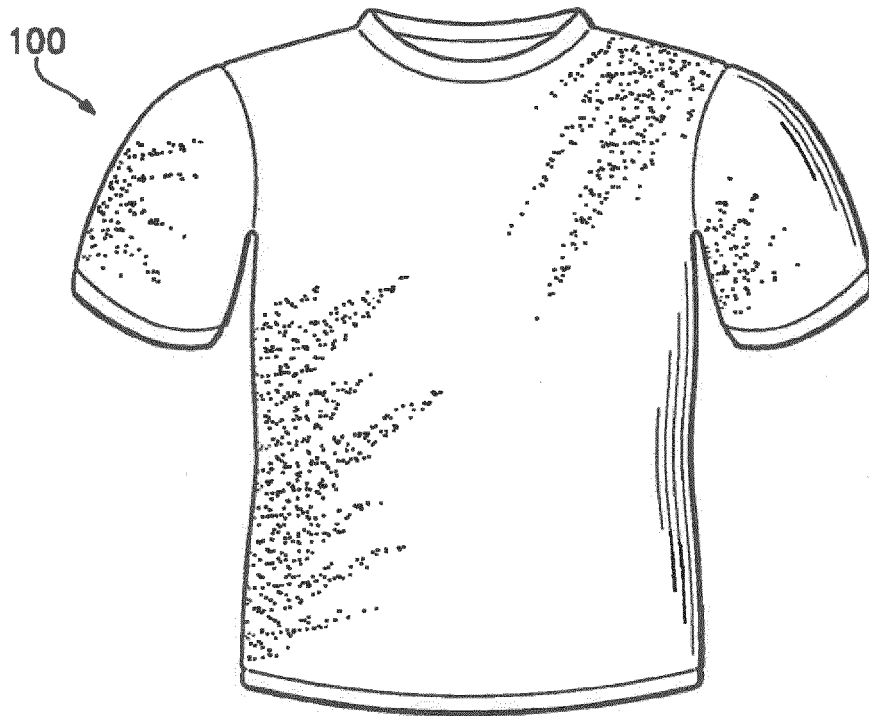

Figure 3E

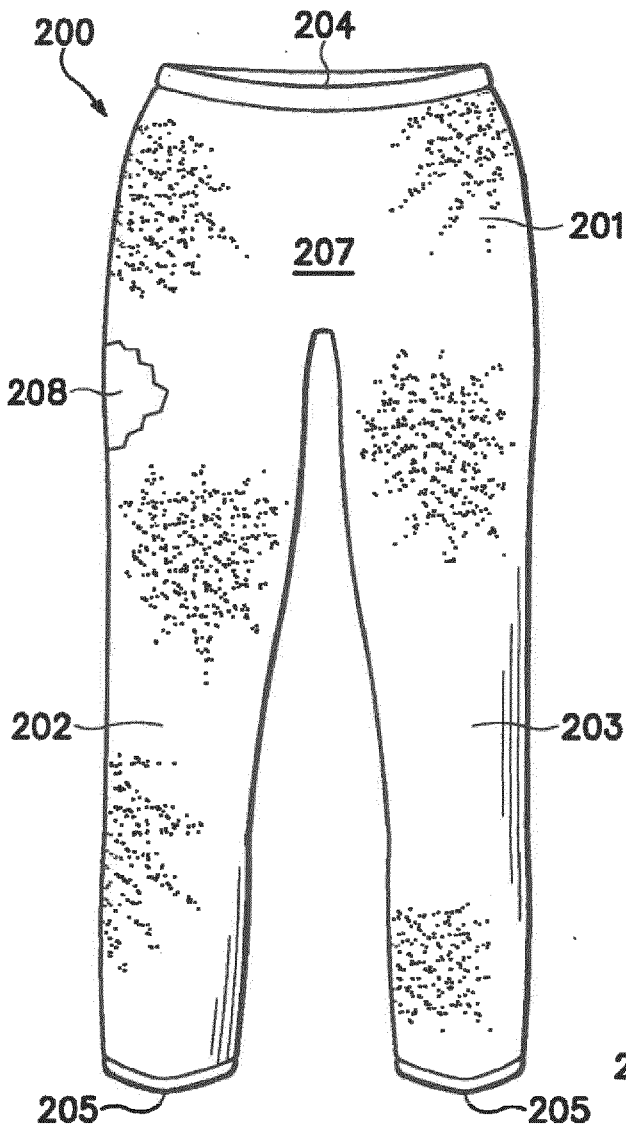

Figure 4

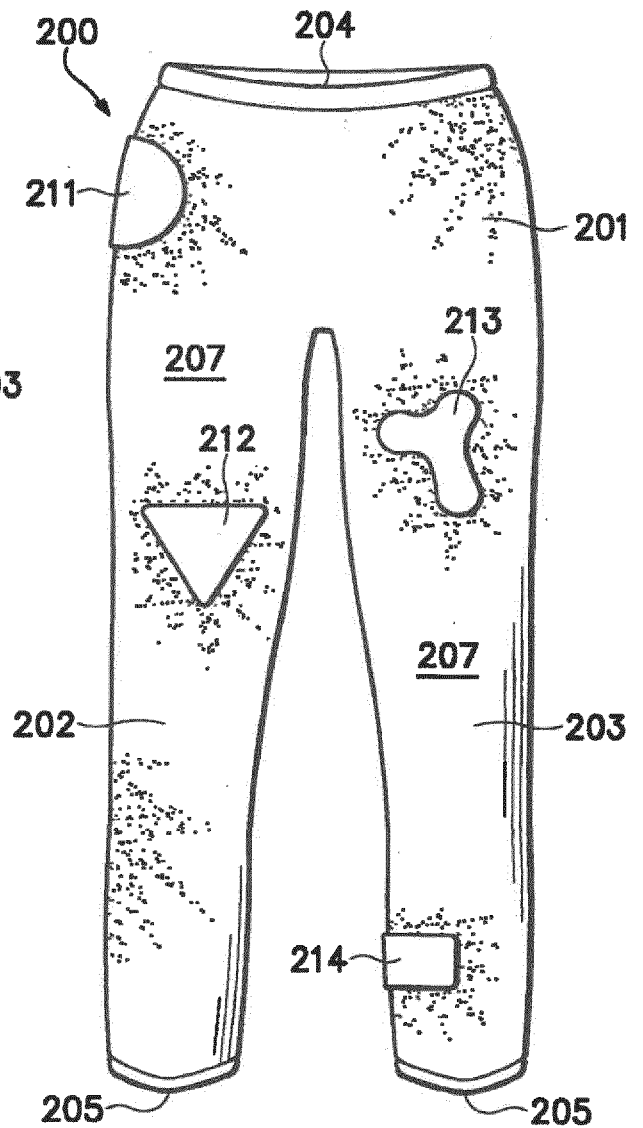

Figure 5A

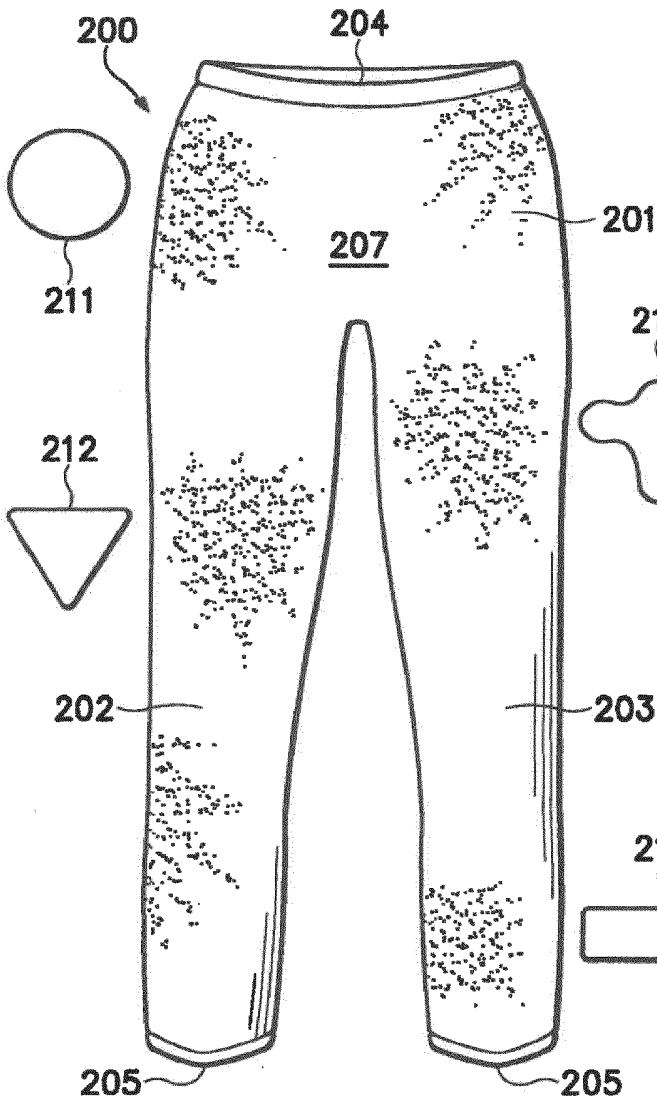

Figure 5B

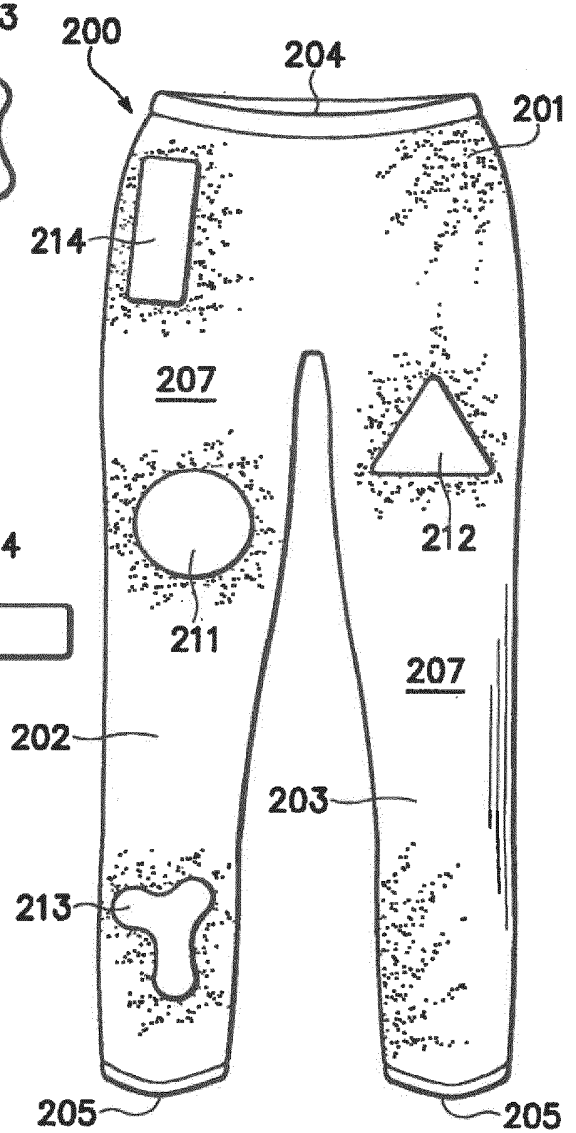

Figure 5C

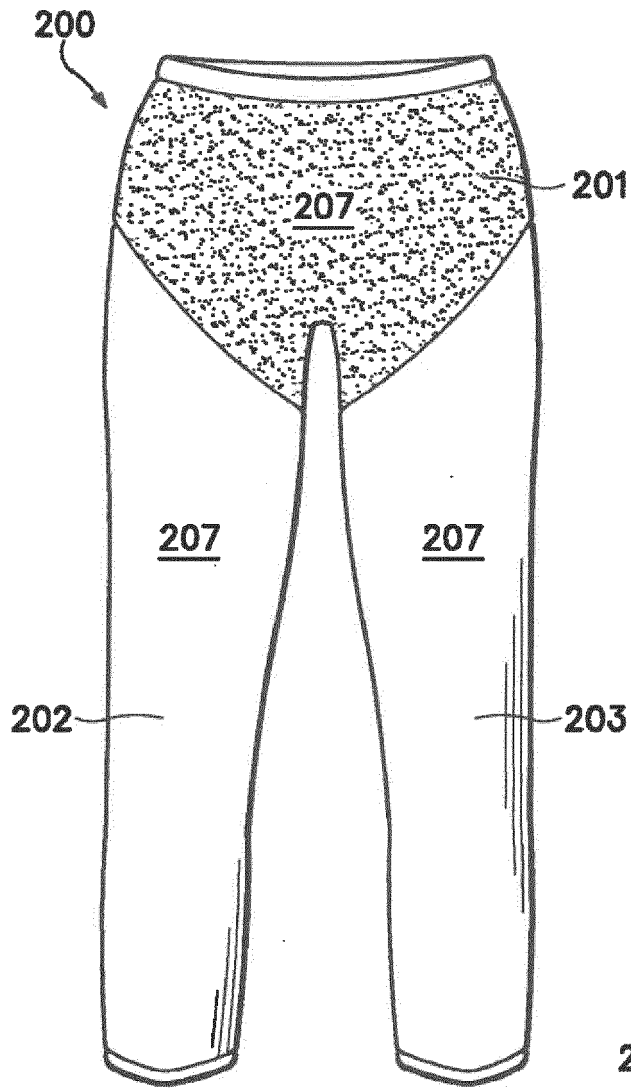

Figure 6A

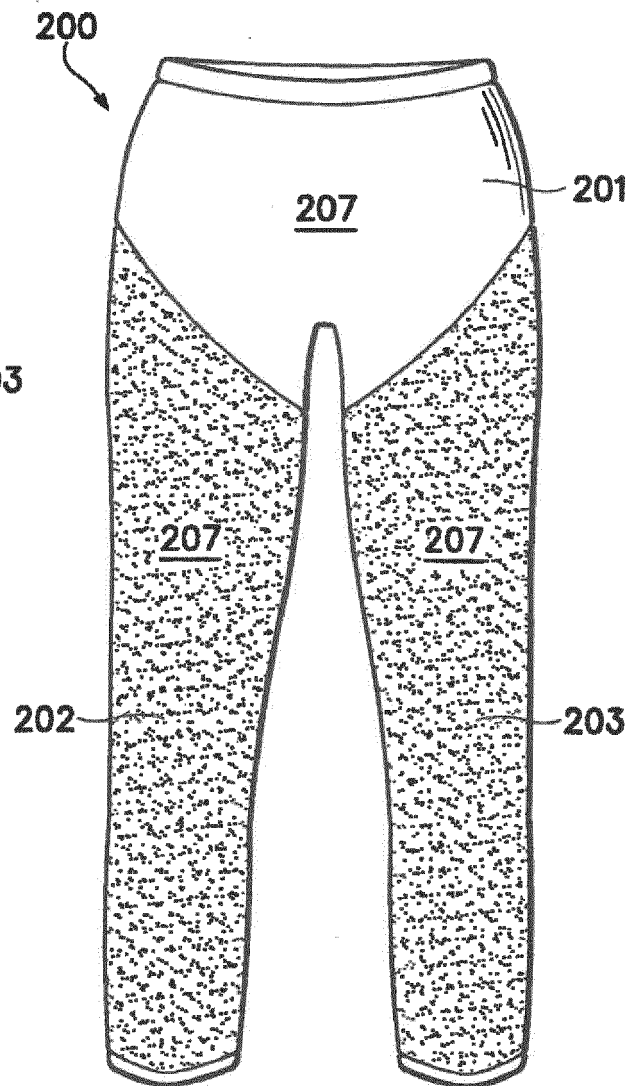

Figure 6B

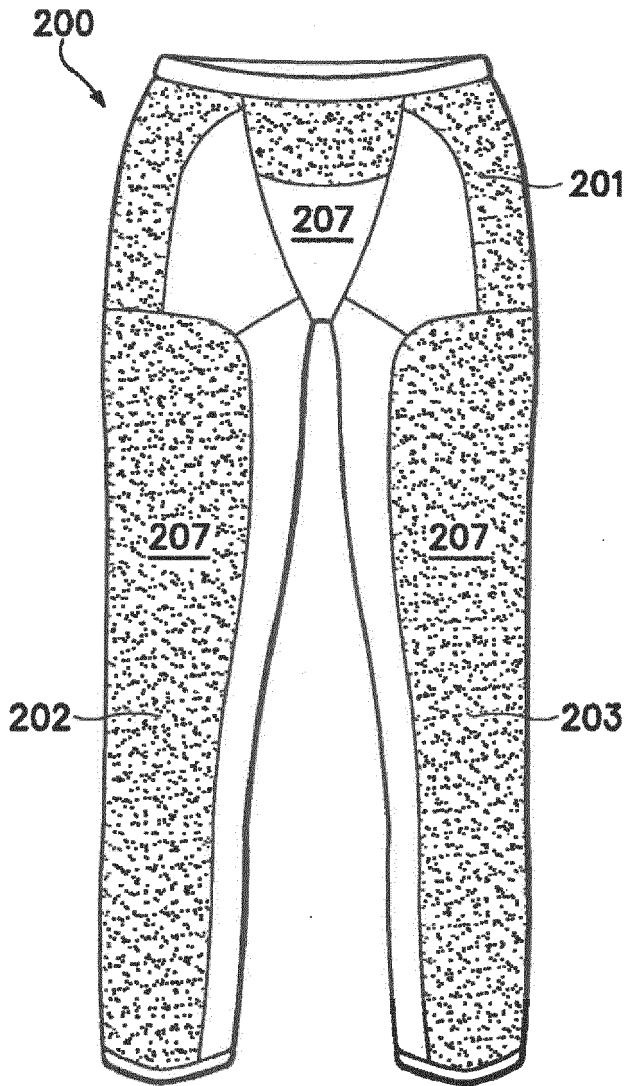

Figure 6C

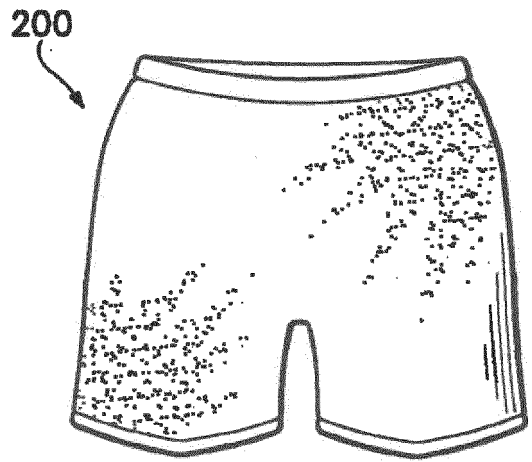

Figure 6D

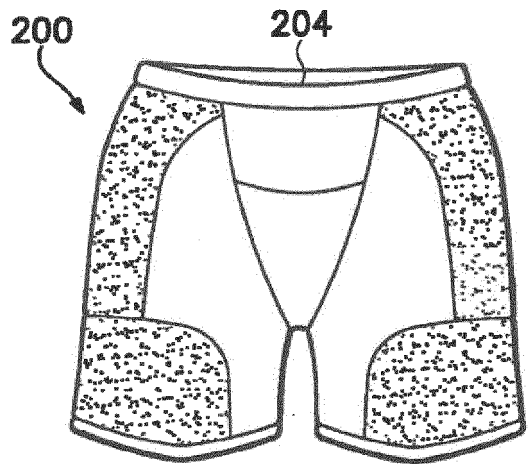

Figure 6E

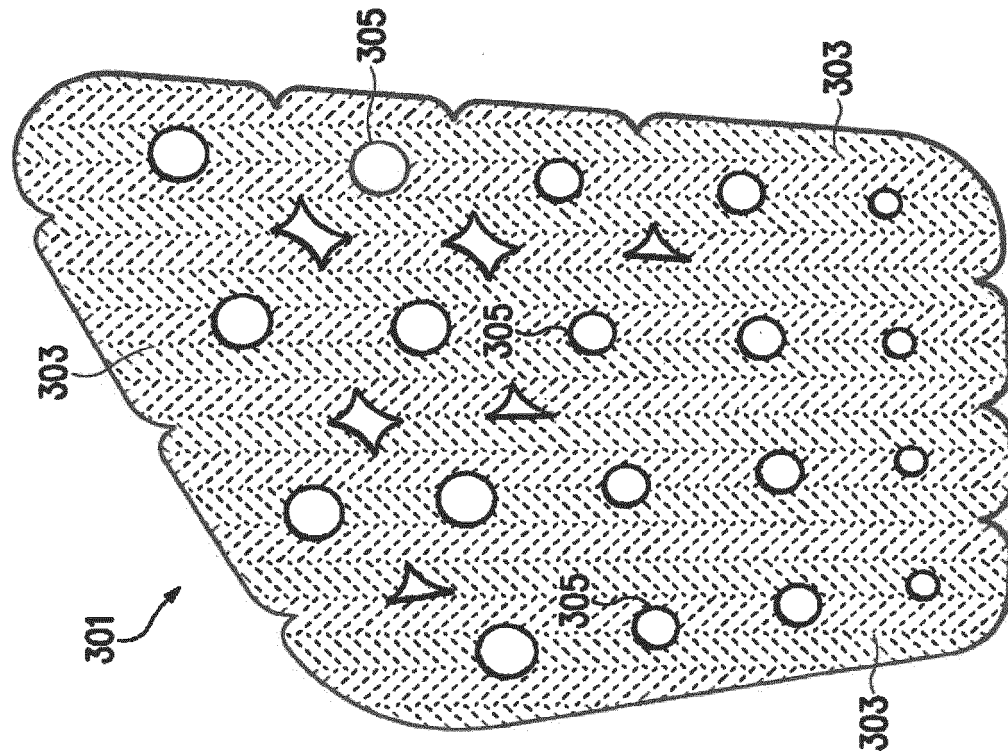

Figure 8

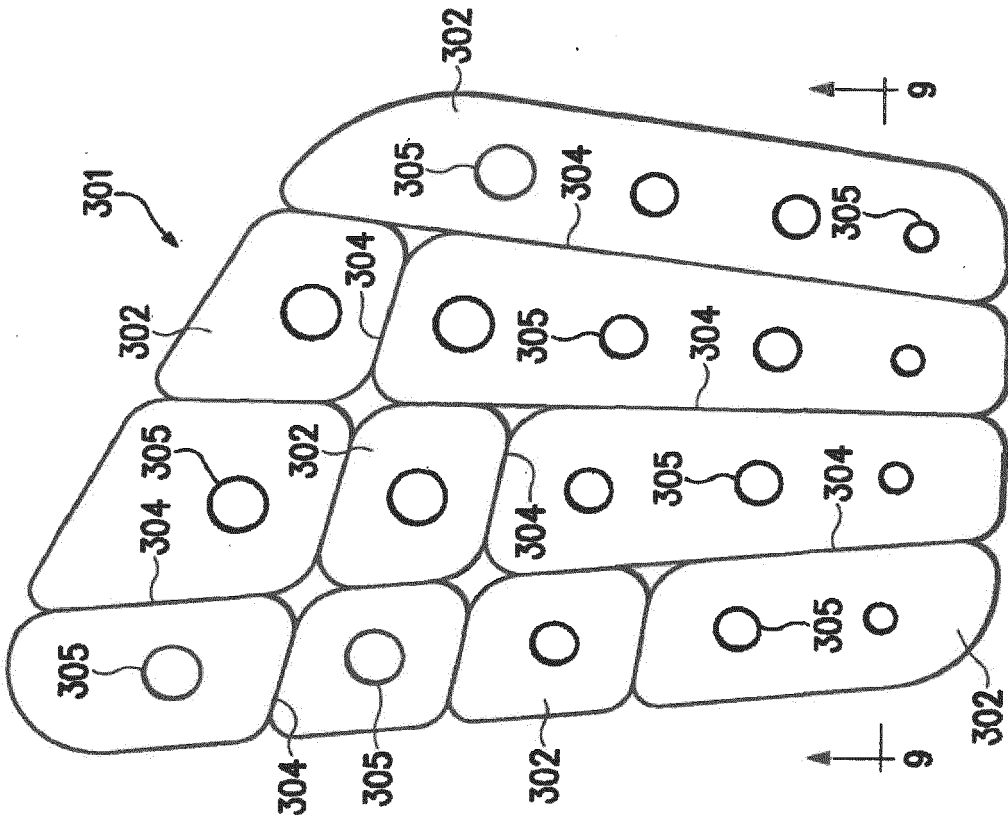
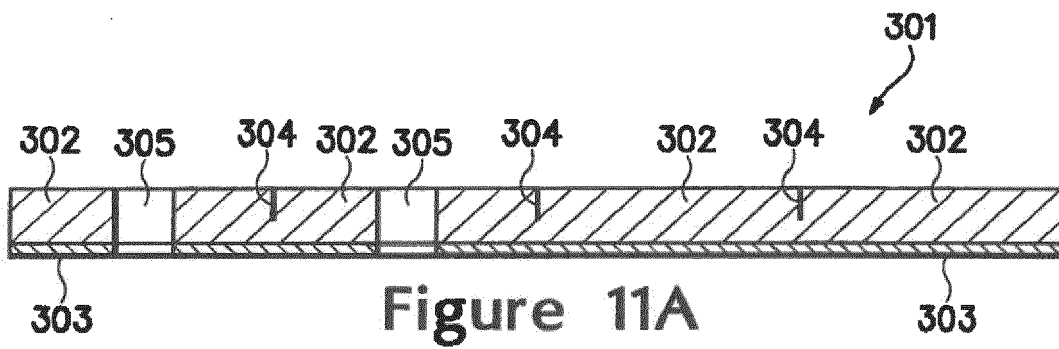
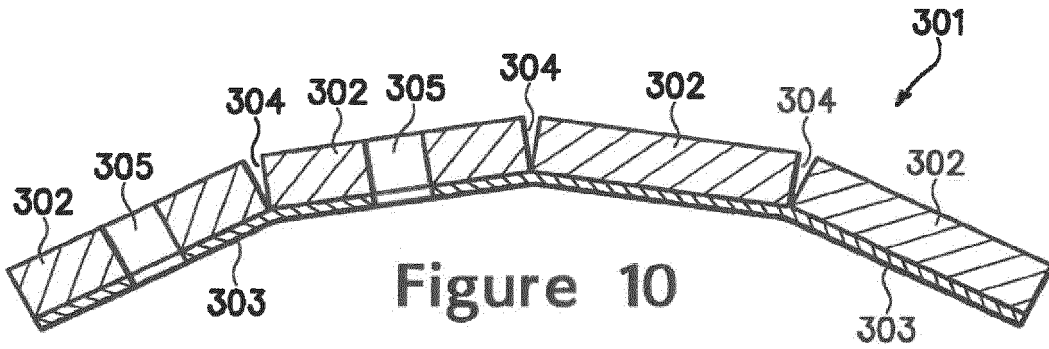
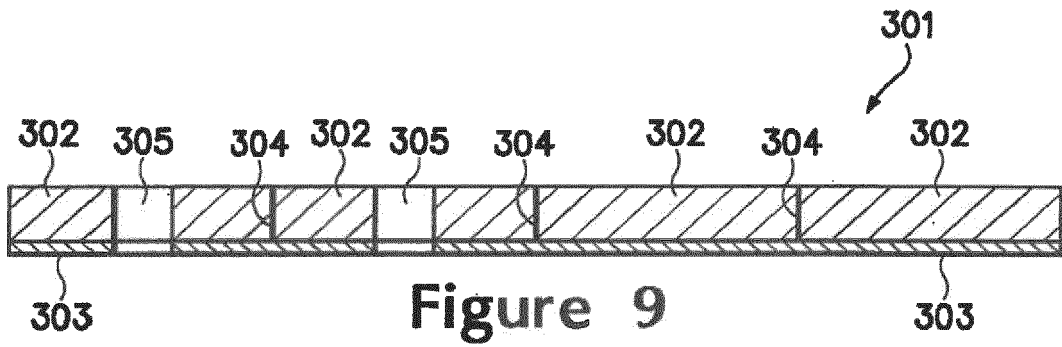
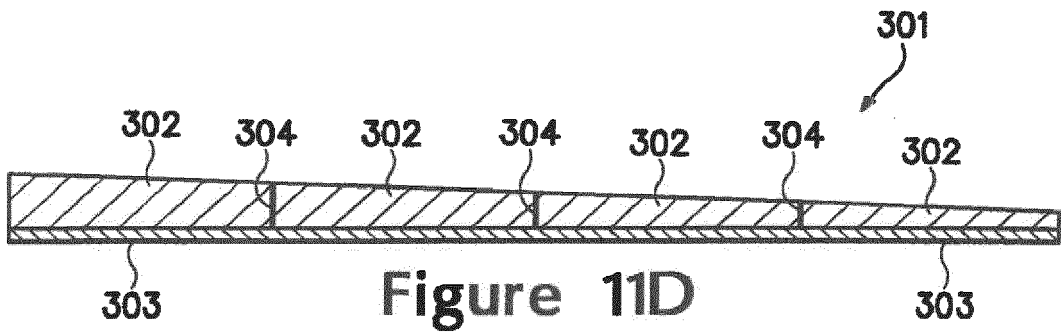
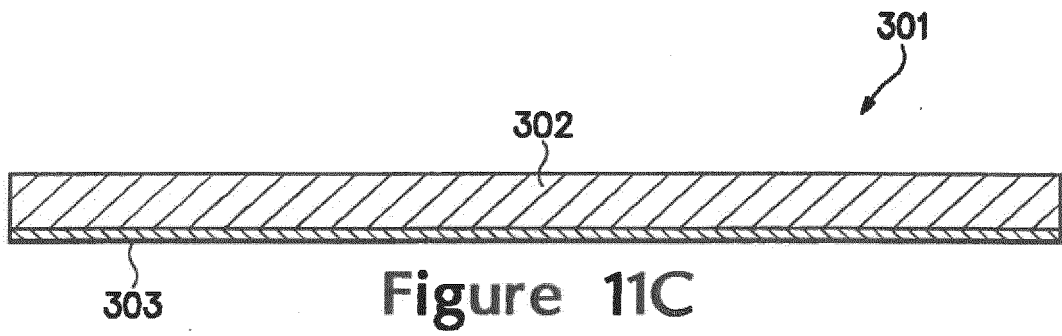
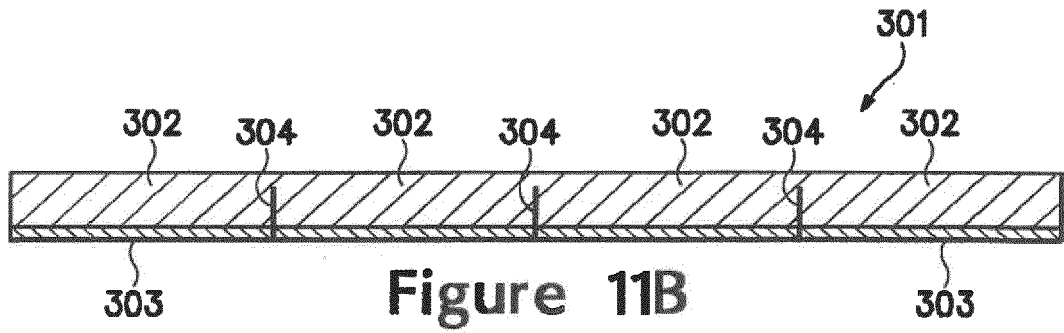

Figure 7





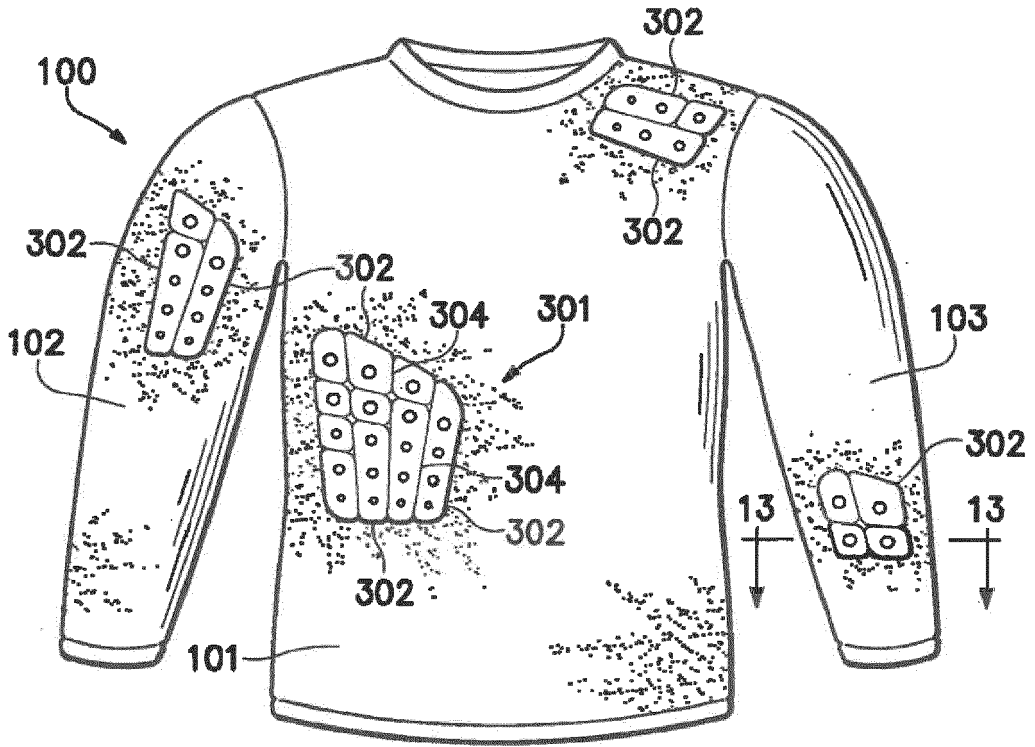

Figure 12

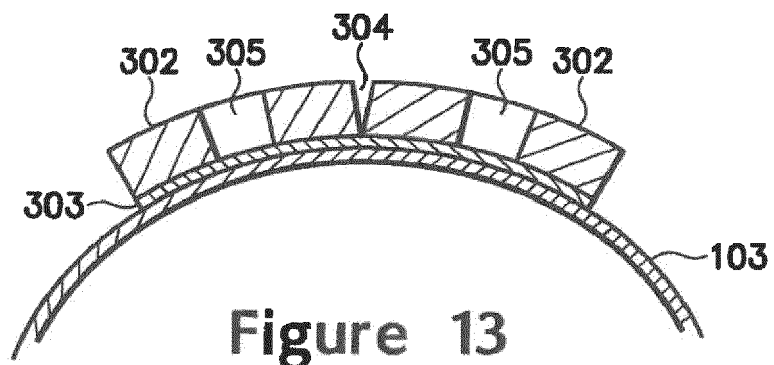

Figure 13

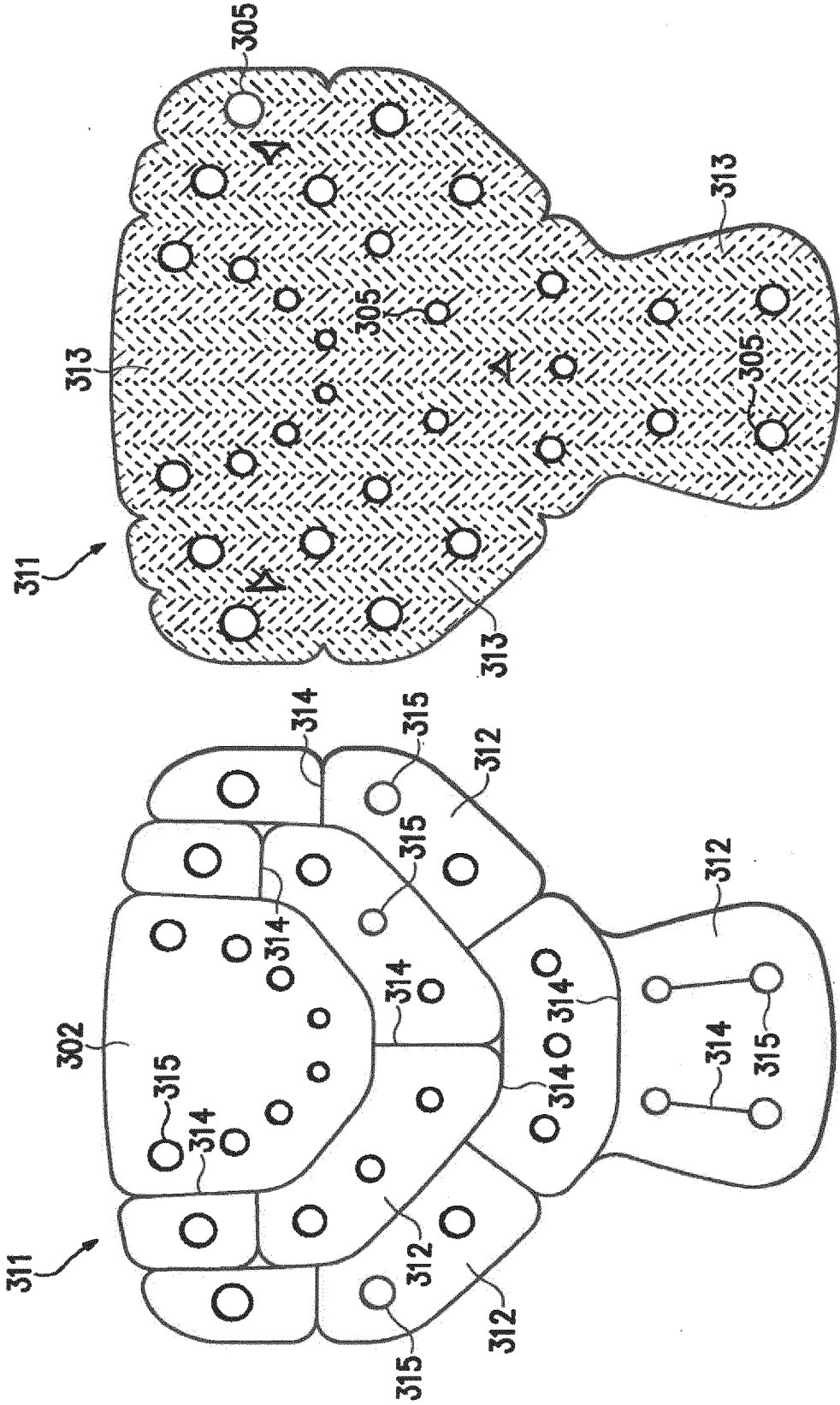

Figure 15

Figure 14

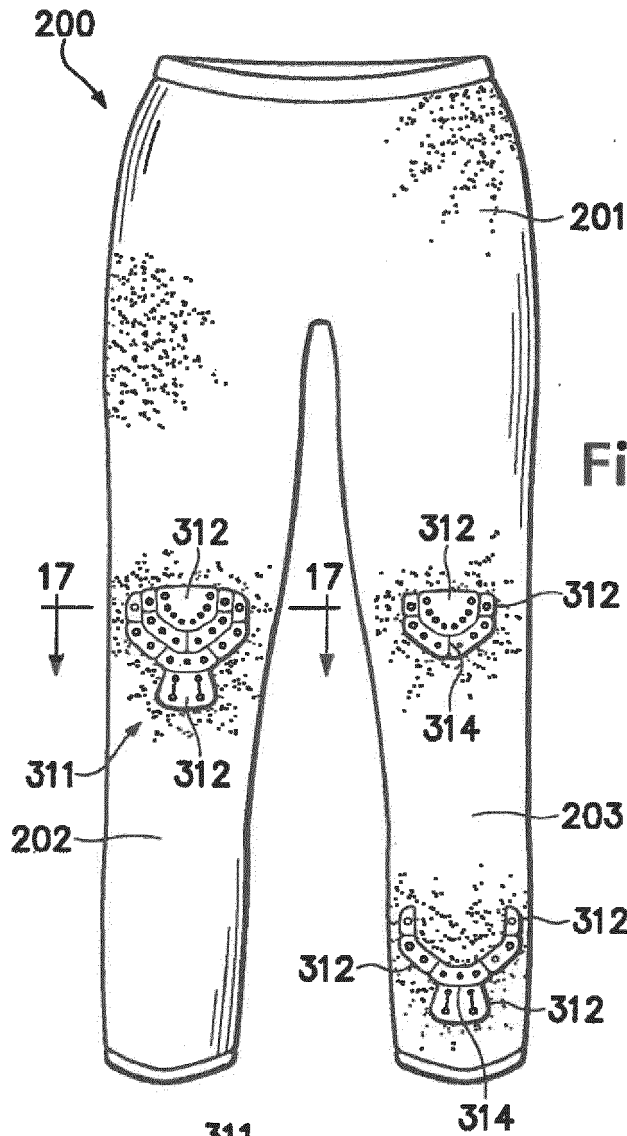

Figure 16

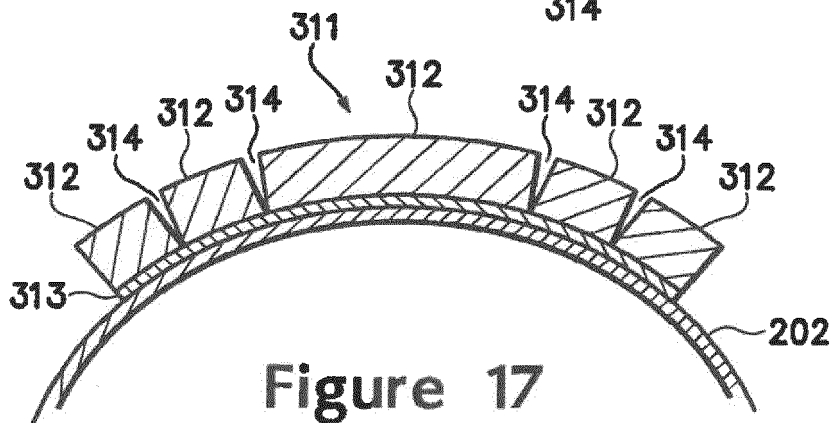

Figure 17

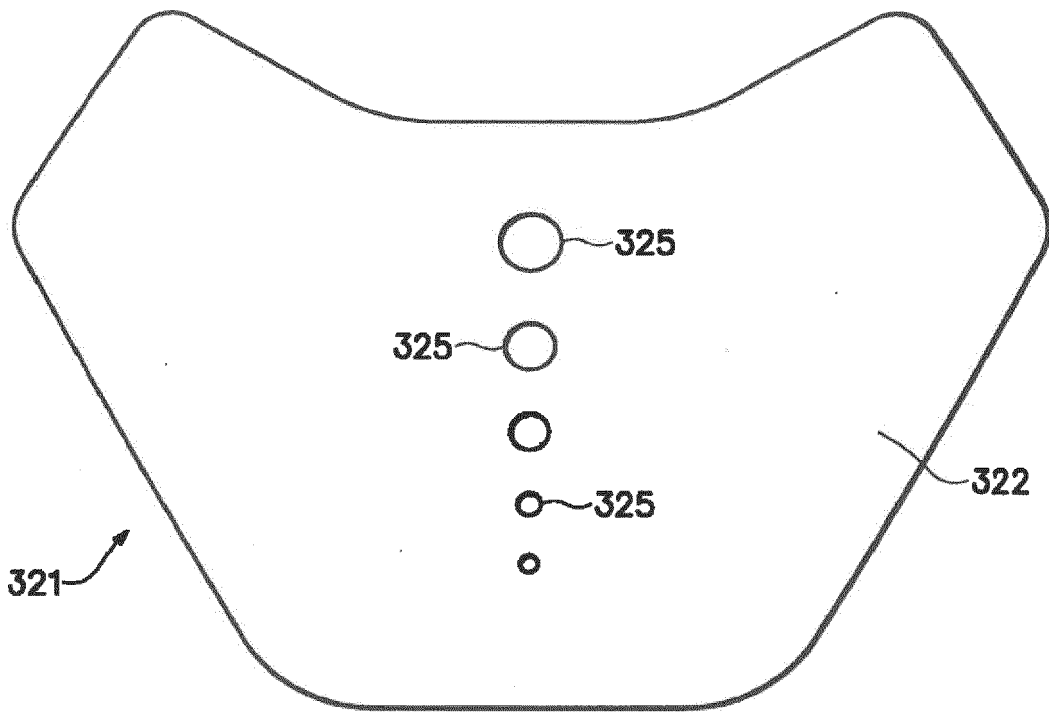

Figure 18

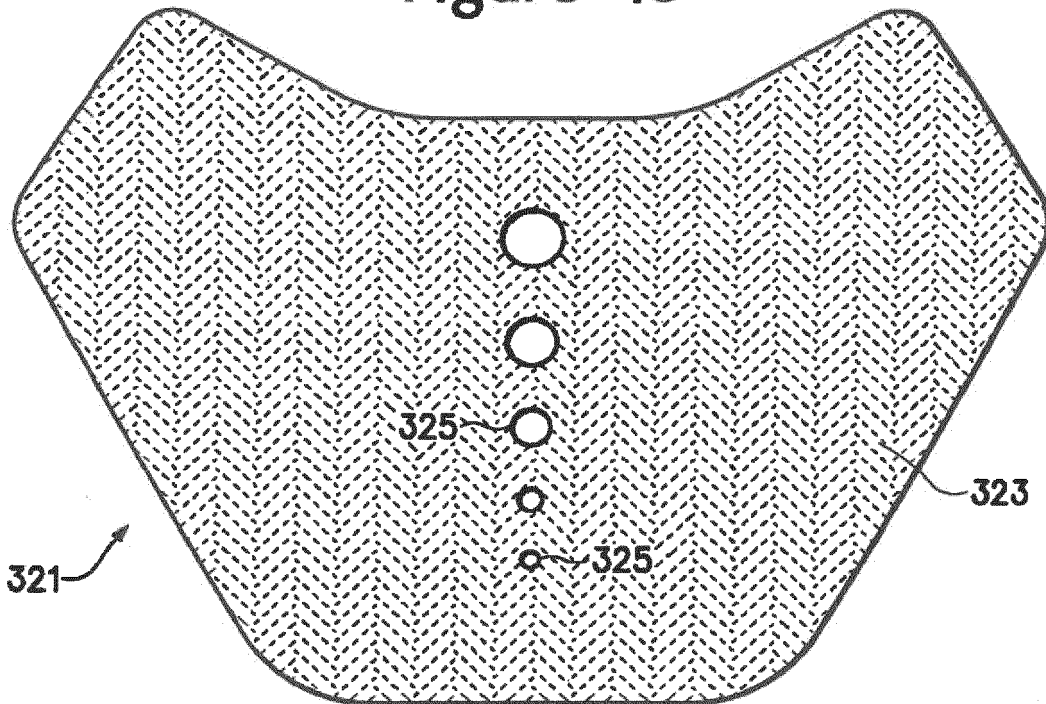
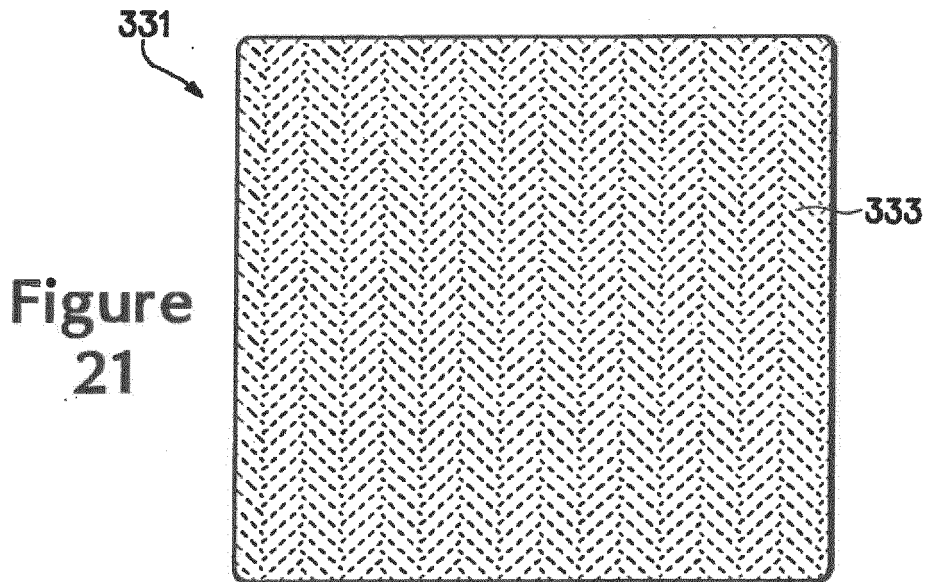
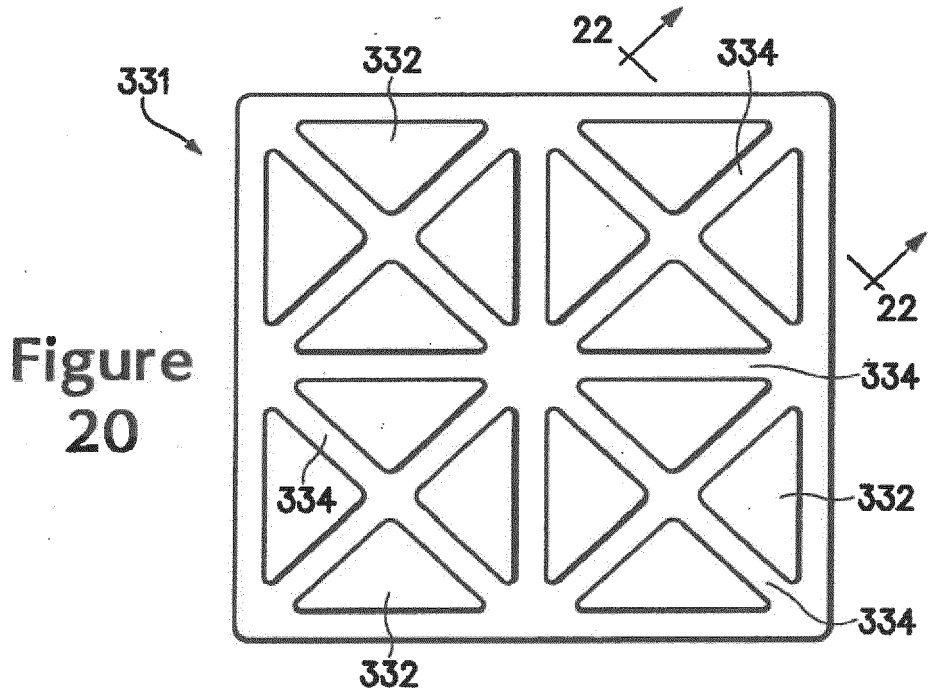

Figure 19



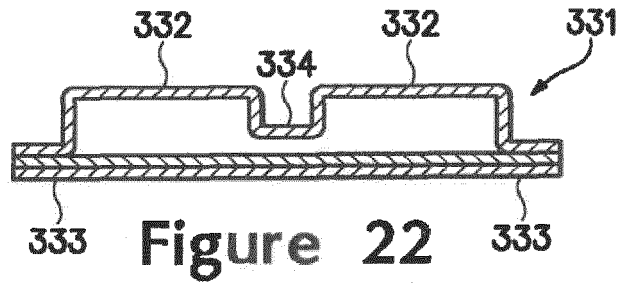

Figure 22

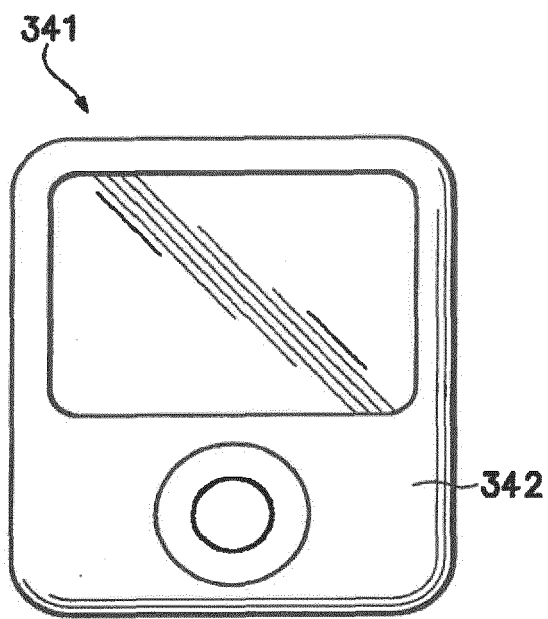

Figure 23

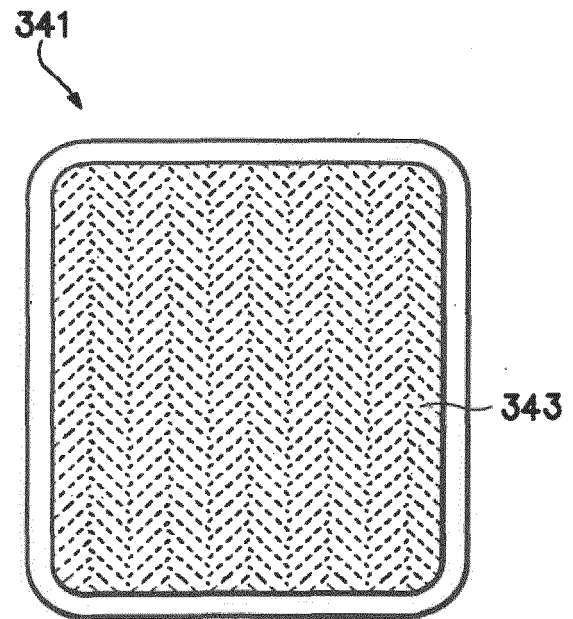

Figure 24

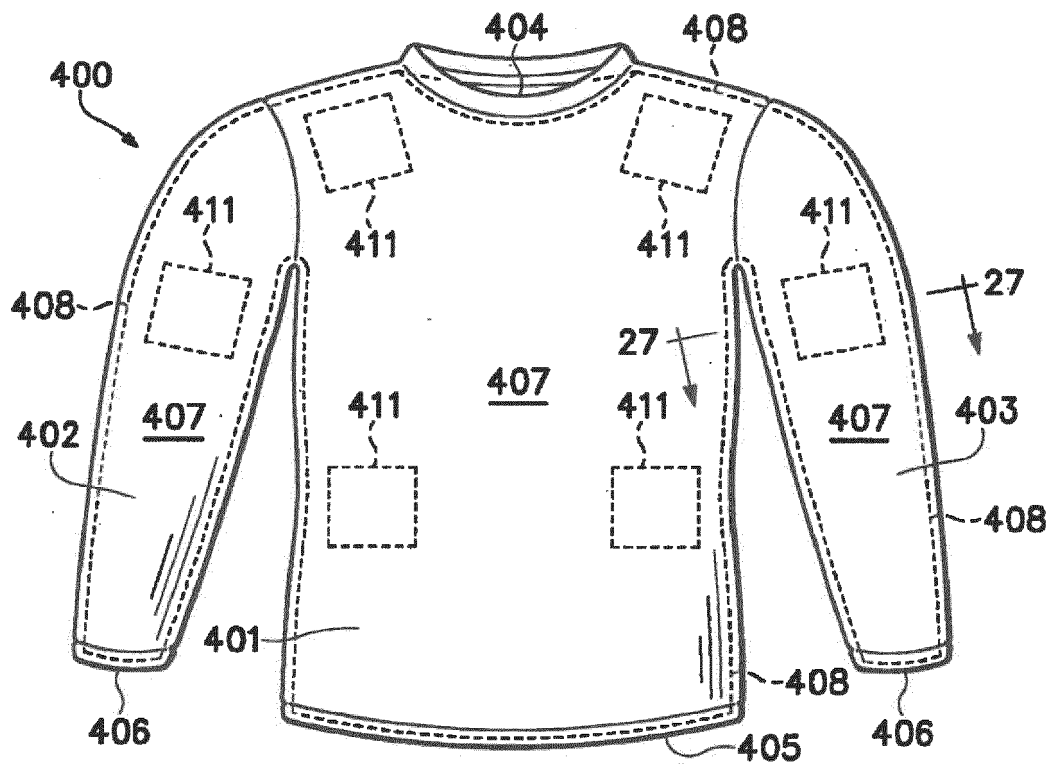

Figure 25

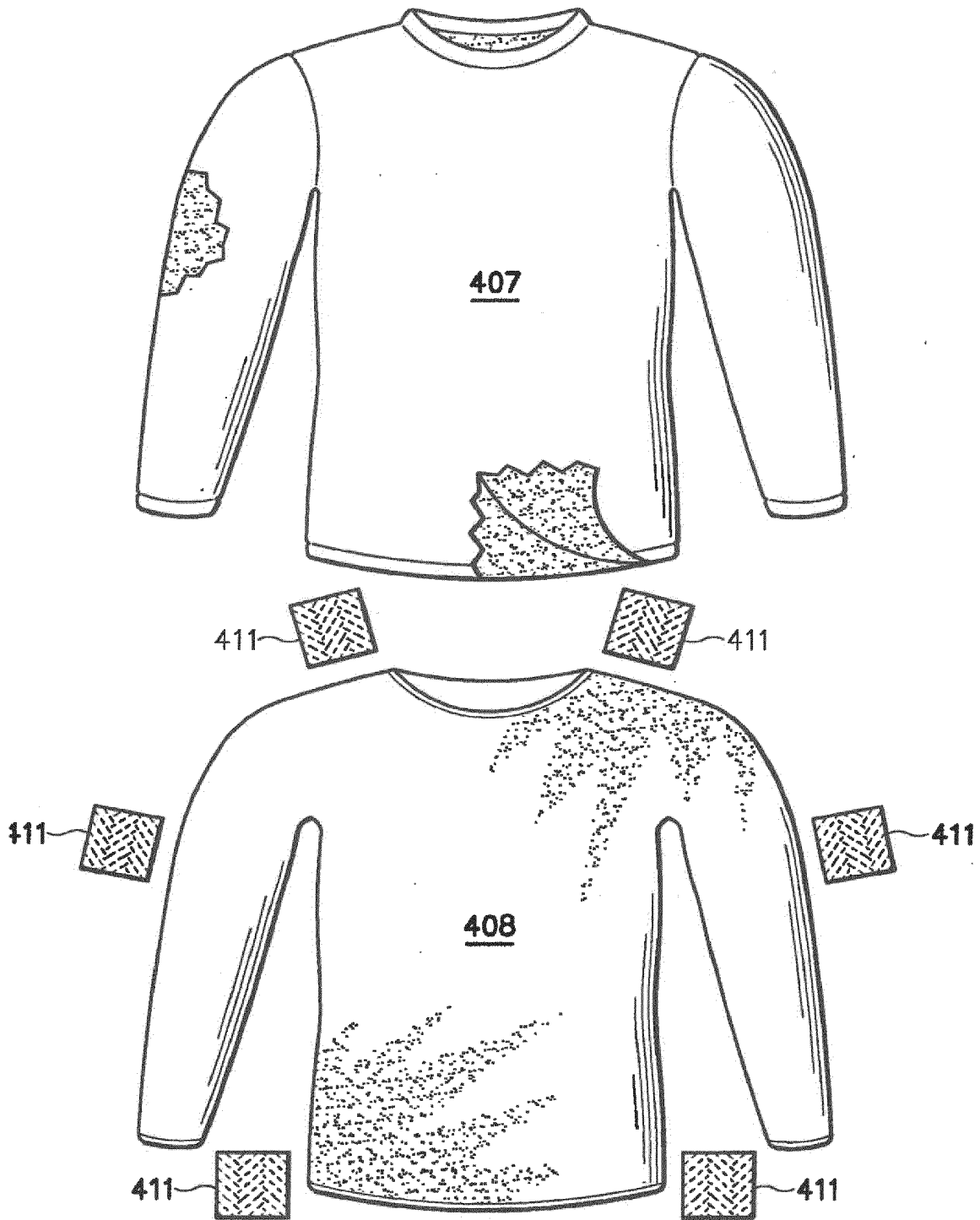

Figure 26

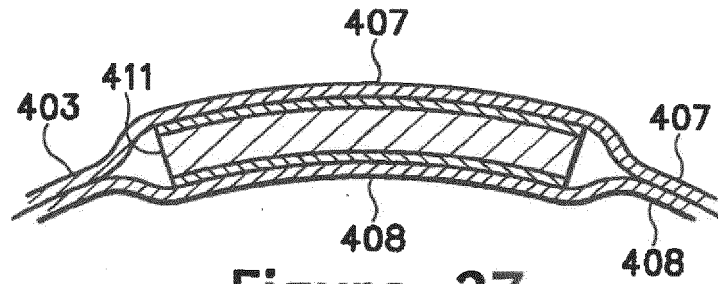

Figure 27

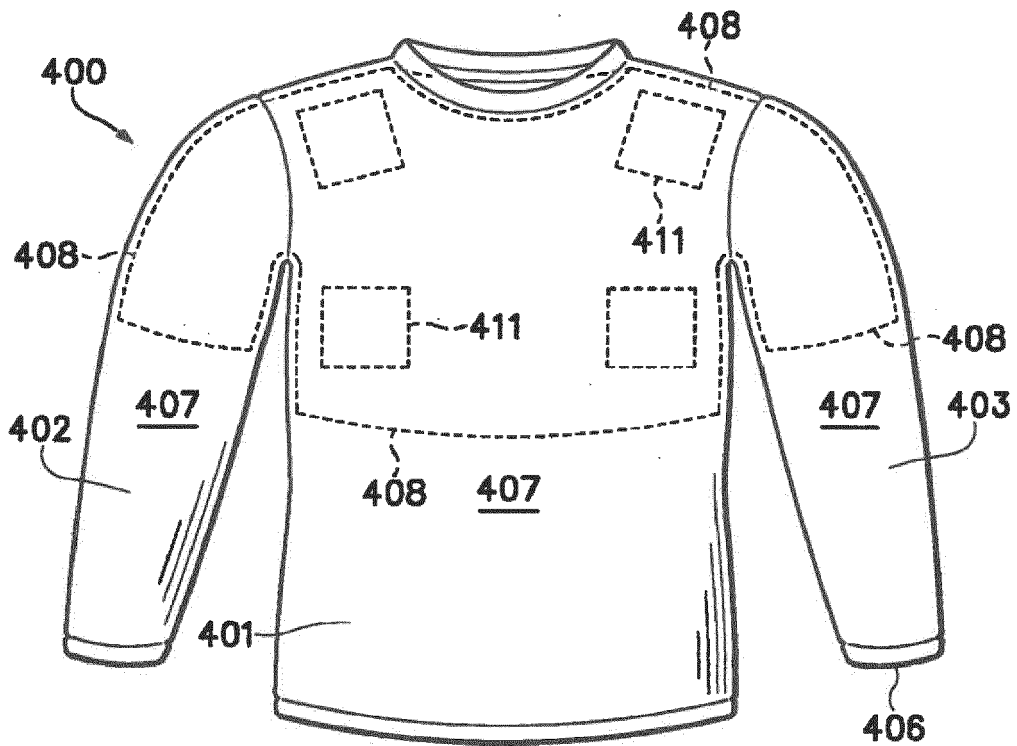

Figure 28A

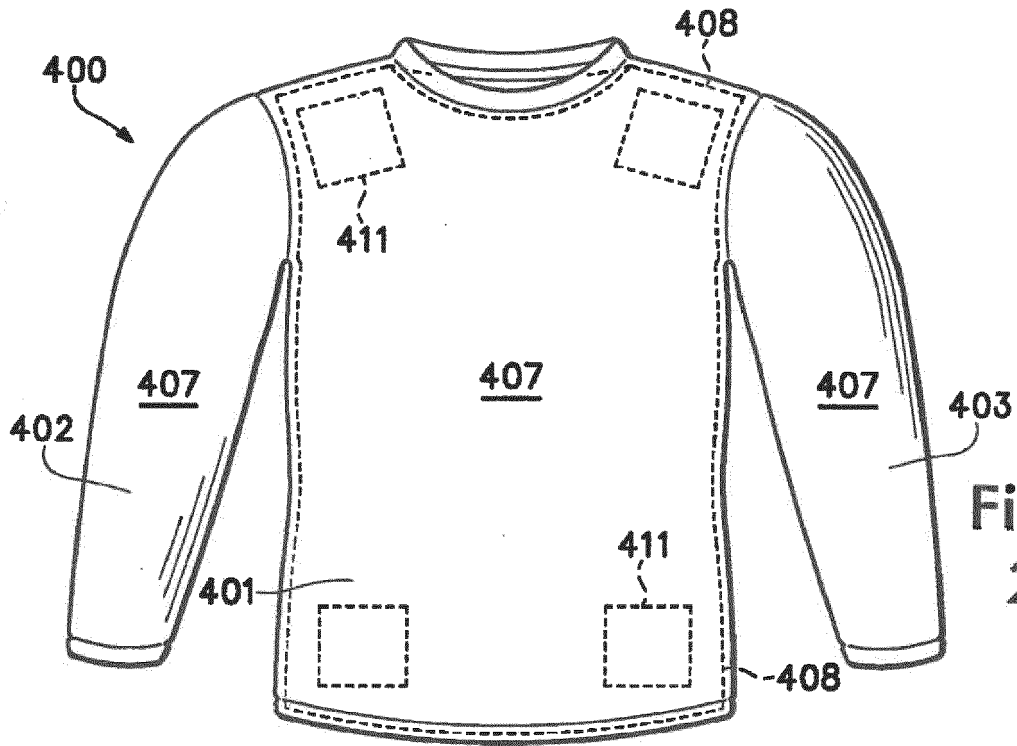

Figure 28B

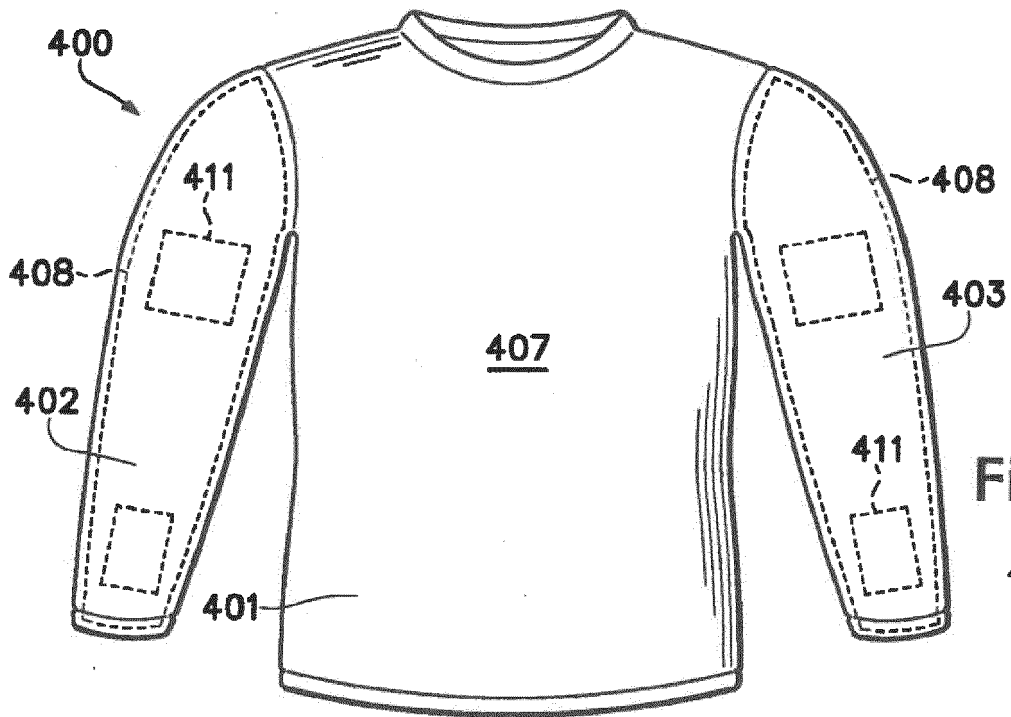

Figure 28C

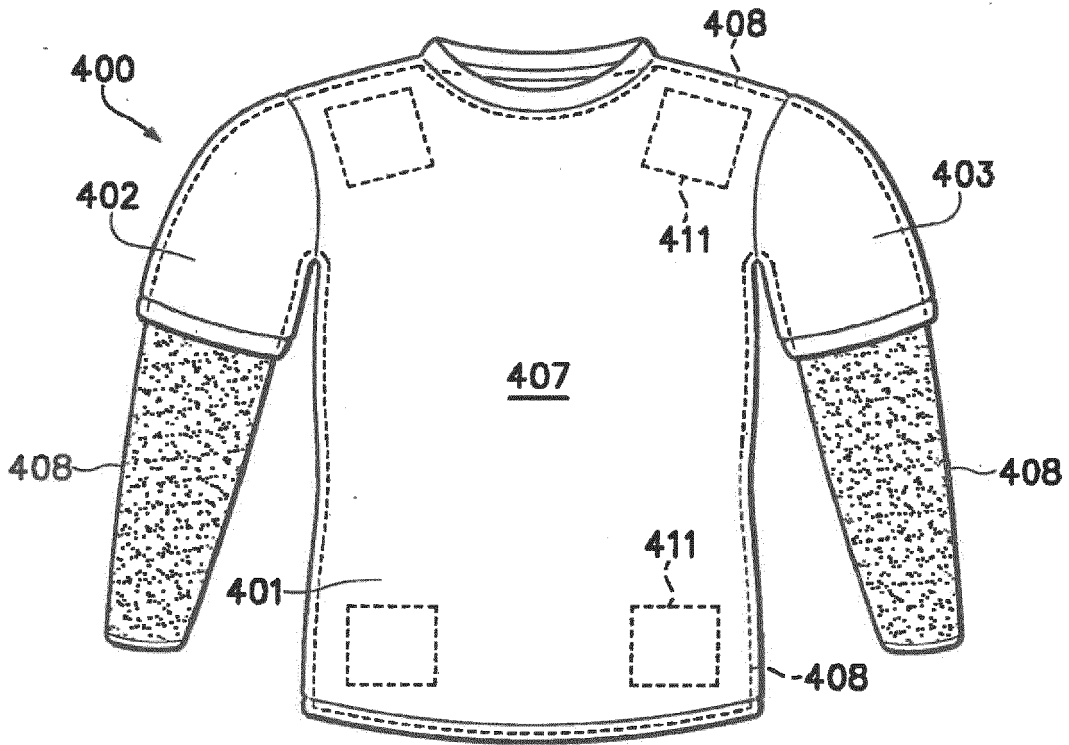

Figure 28D

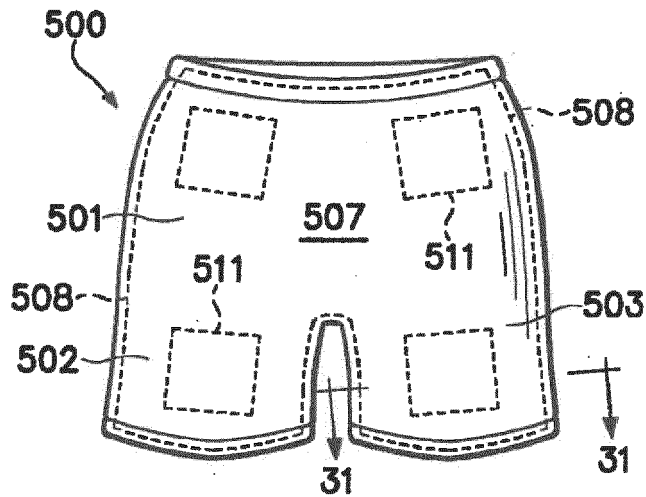

Figure 29

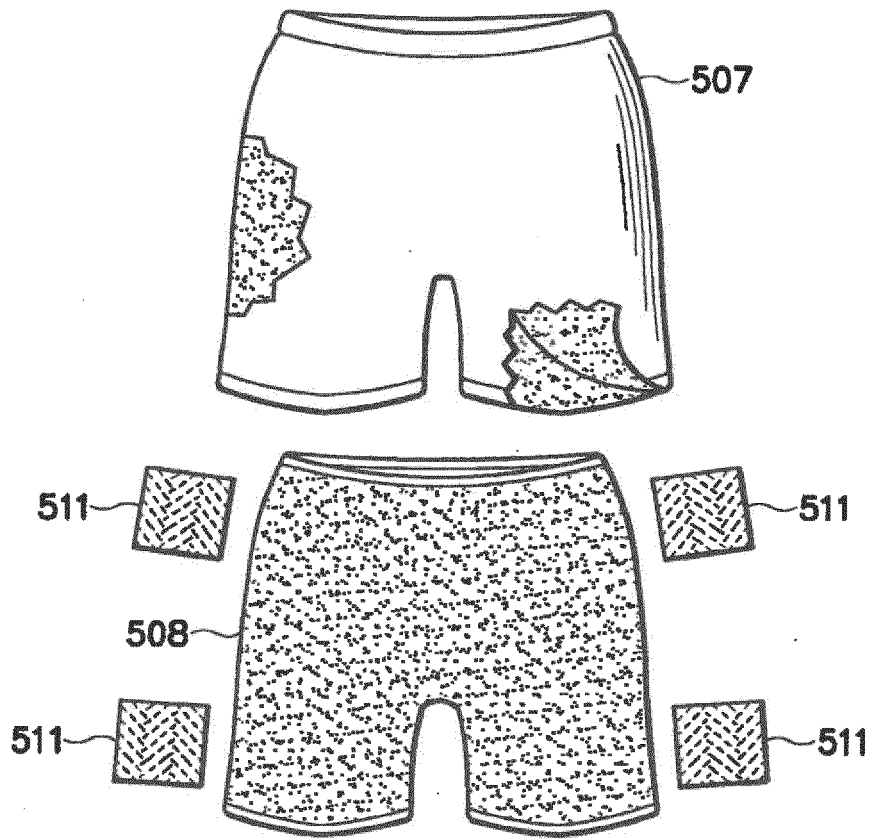

Figure 30

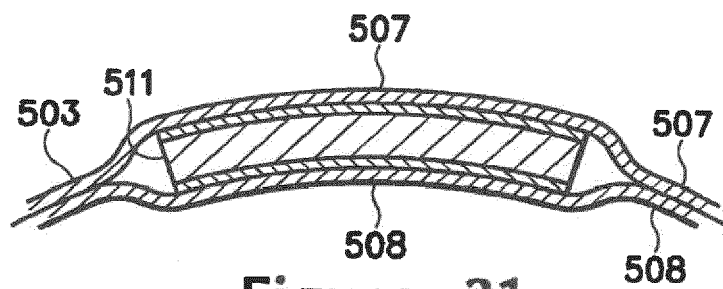

Figure 31

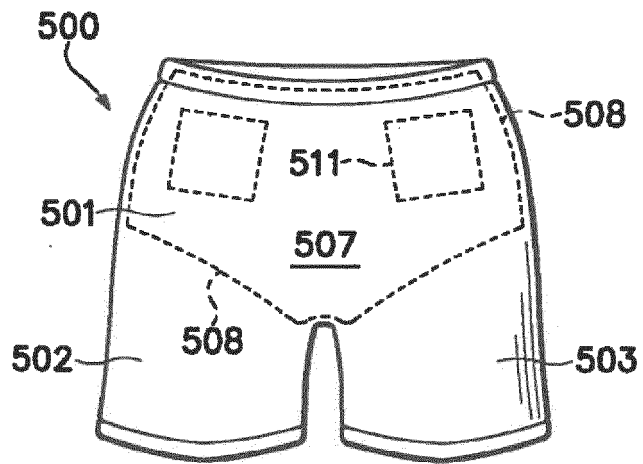

Figure 32A

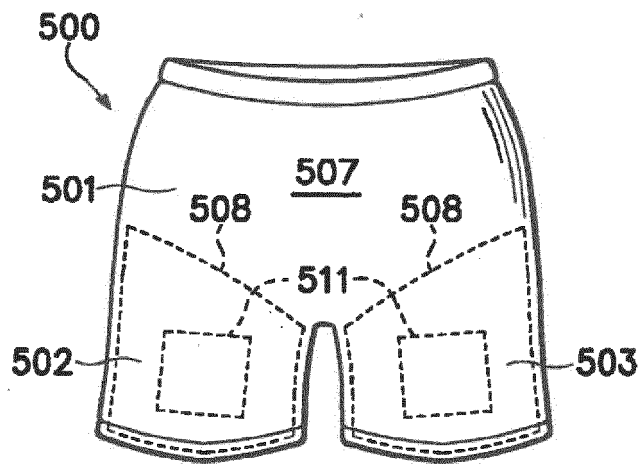

Figure 32B

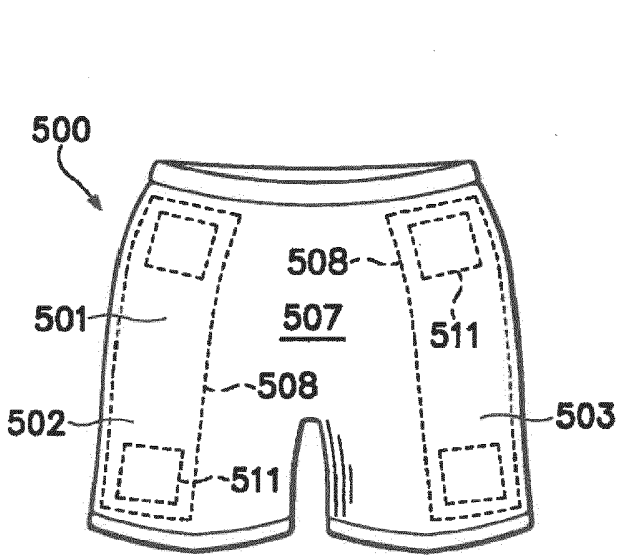

Figure 32C

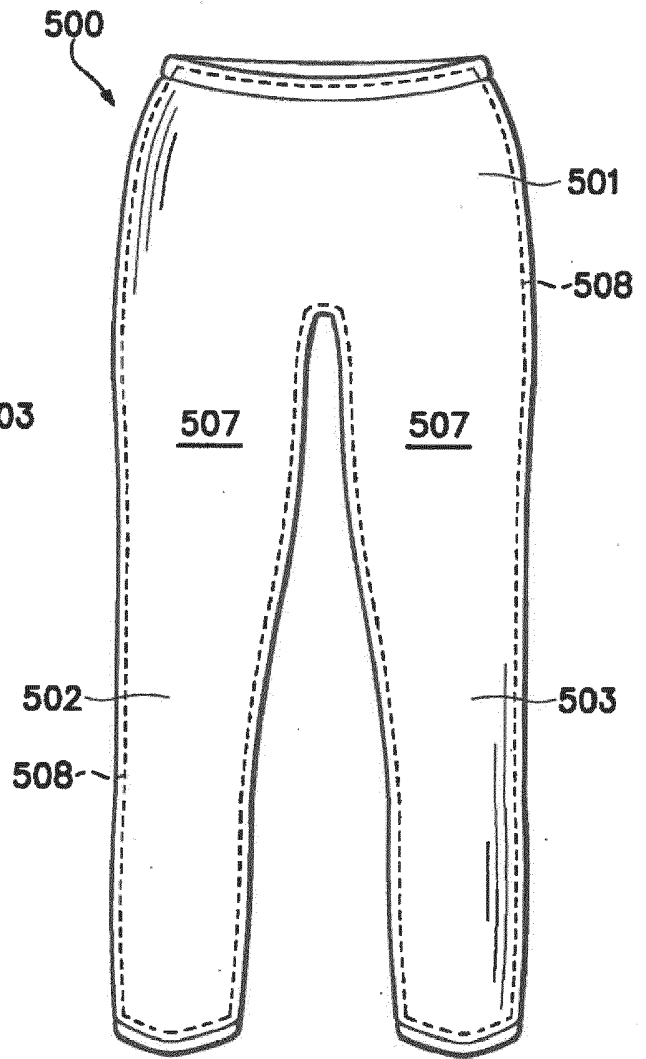

Figure 32D

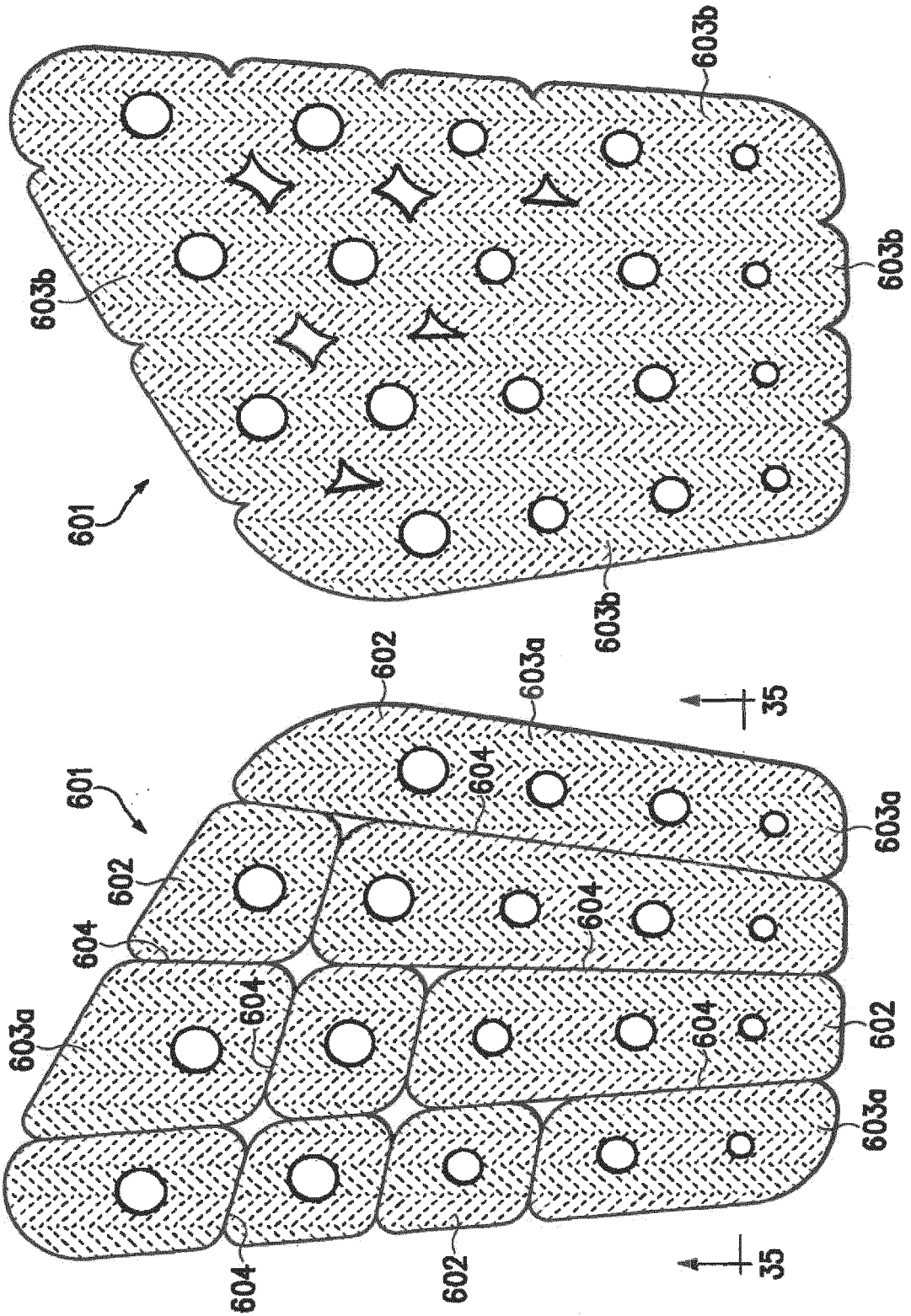
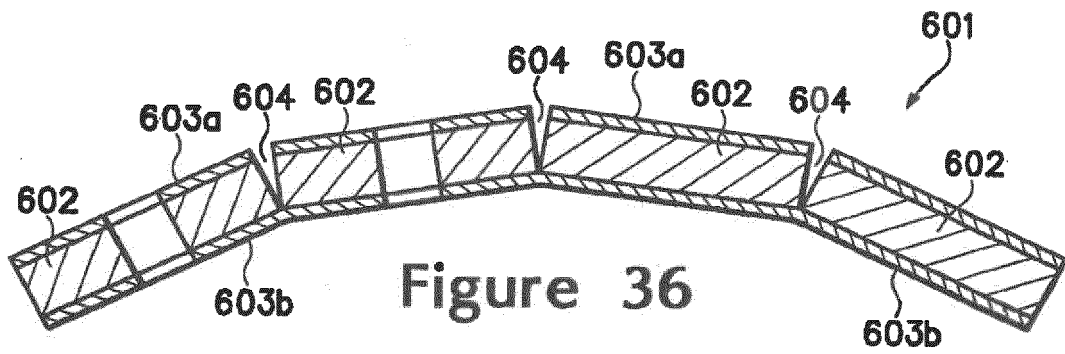
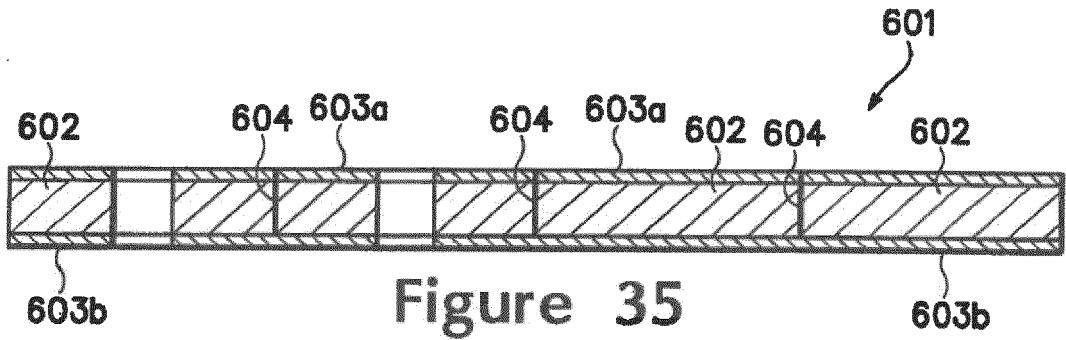

Figure 34

Figure 33



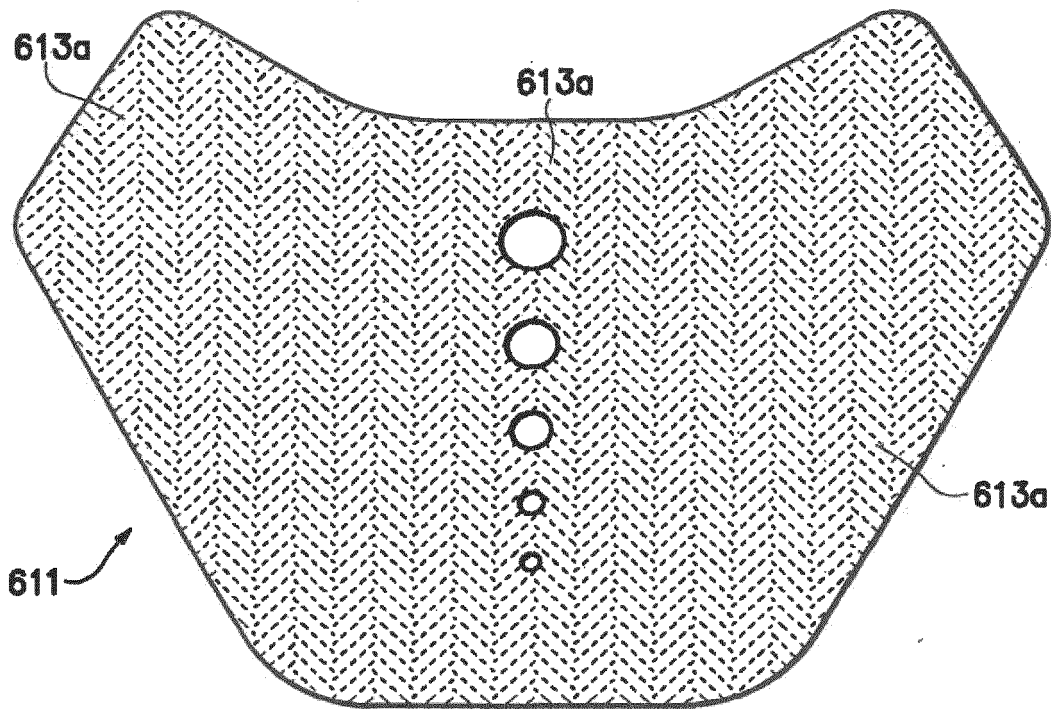

Figure 37

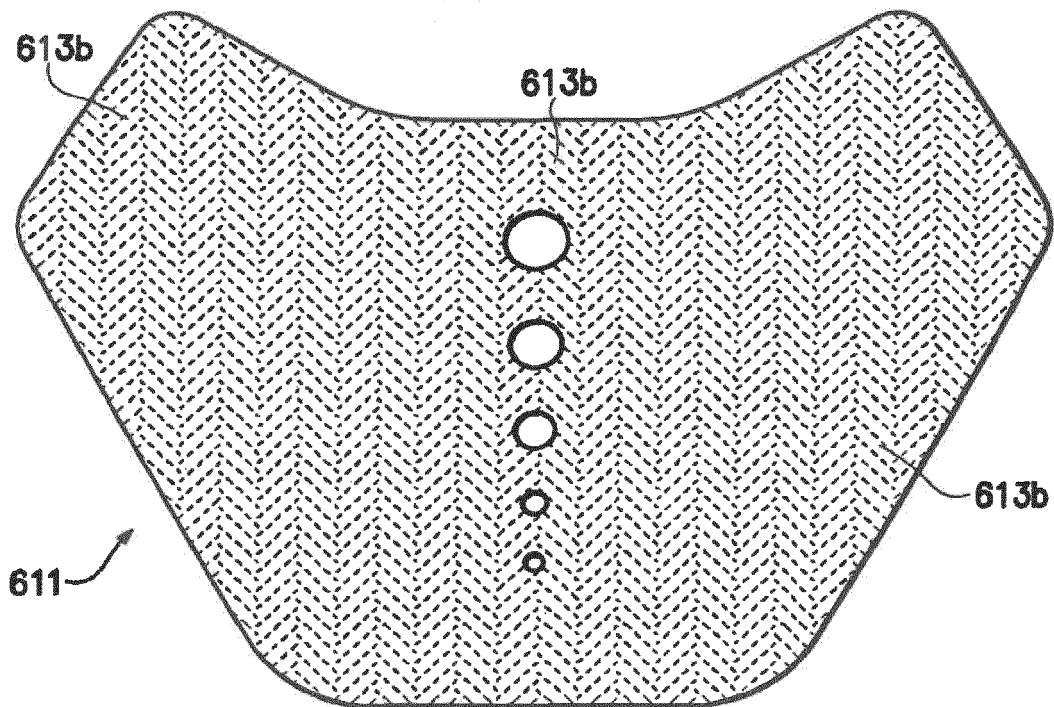
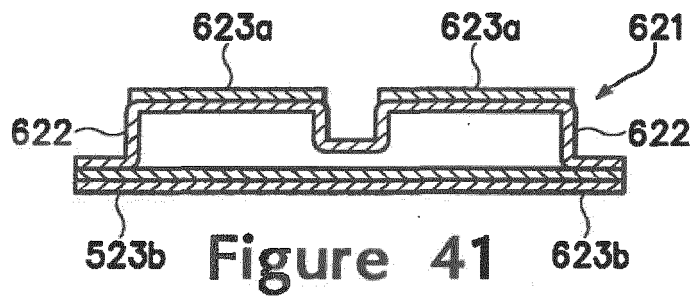
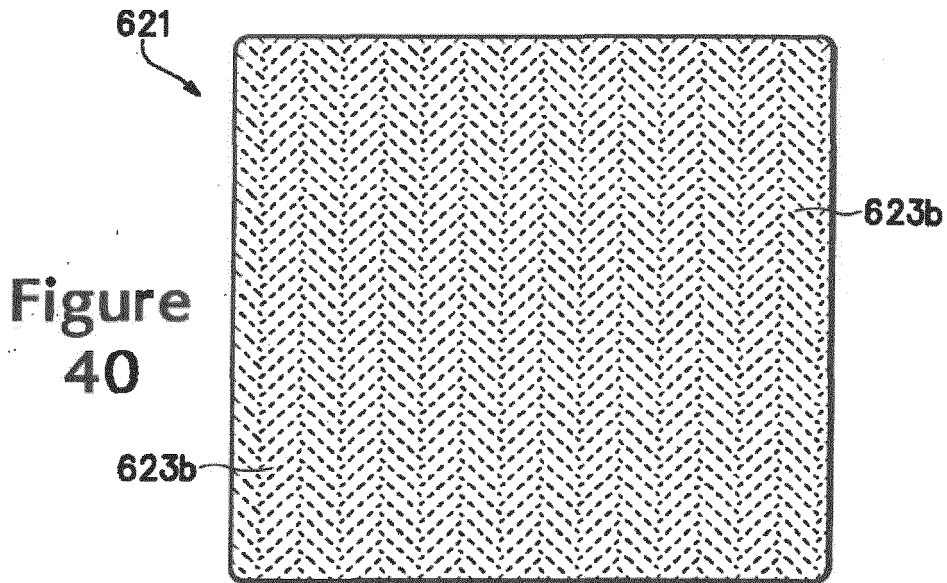
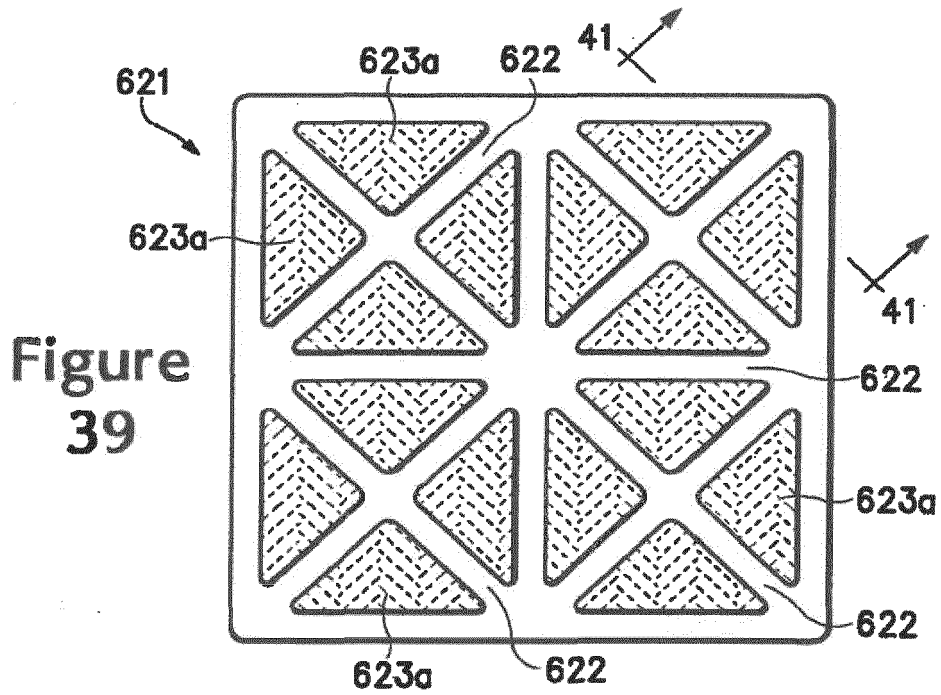
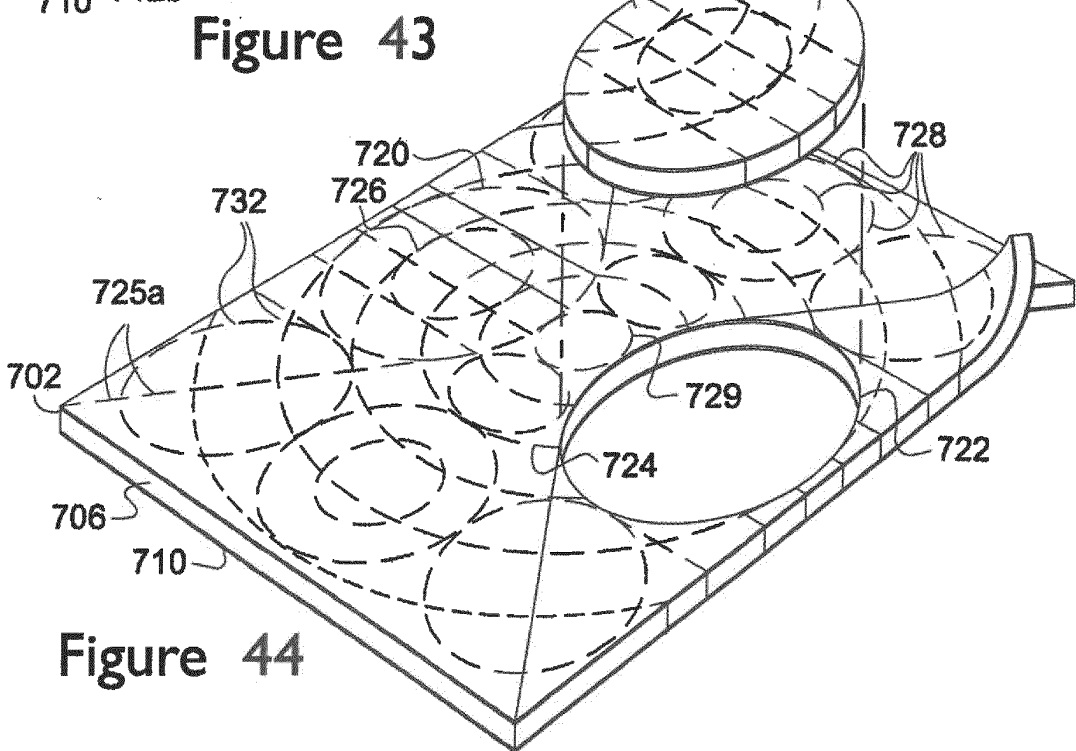
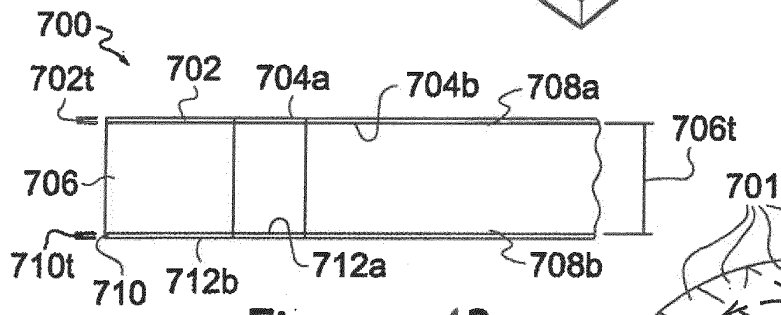
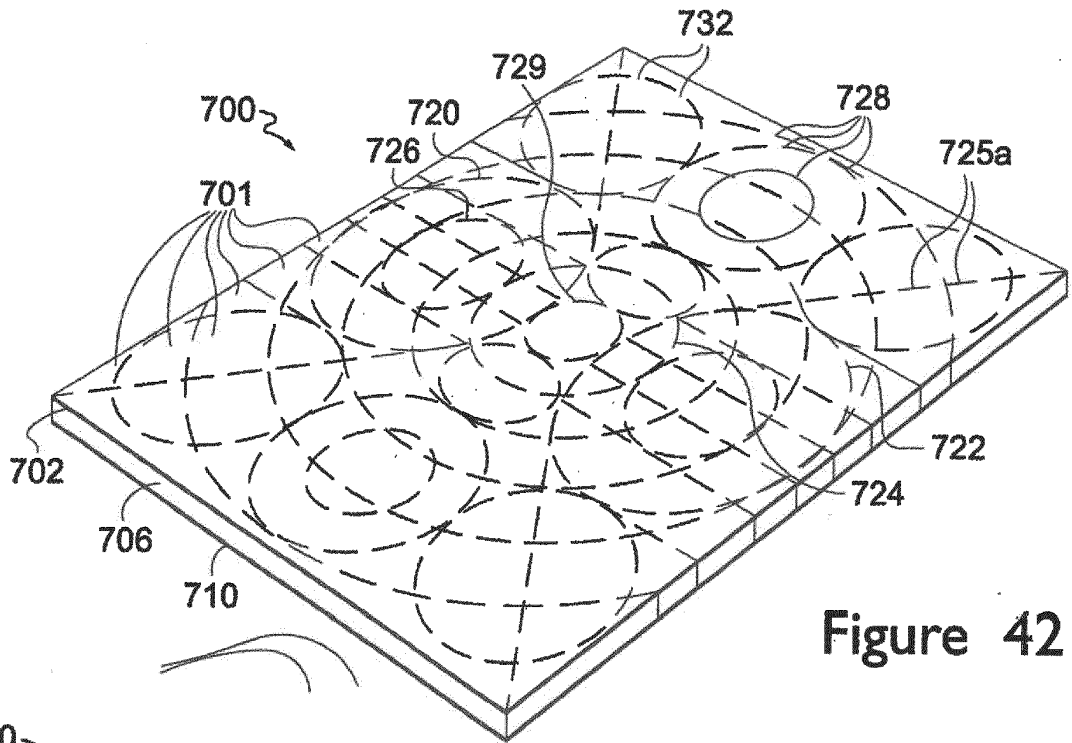
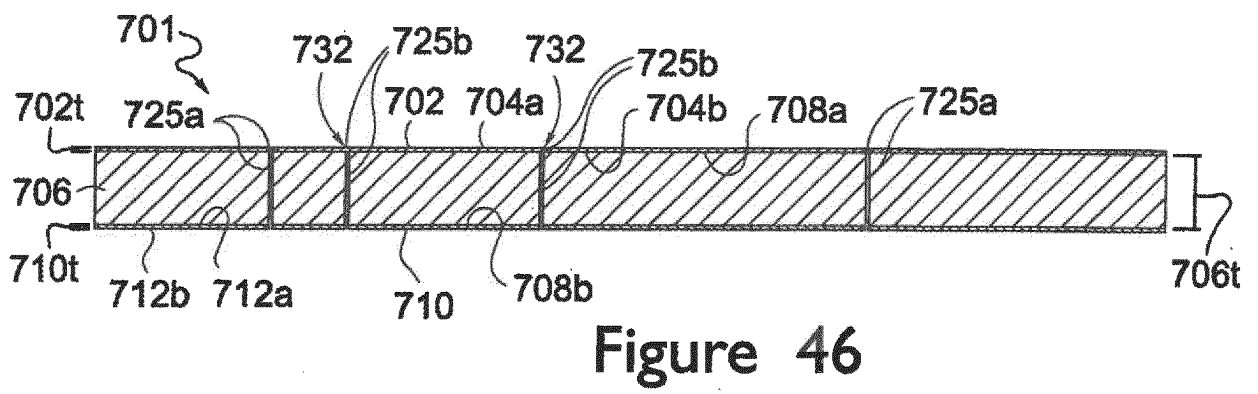
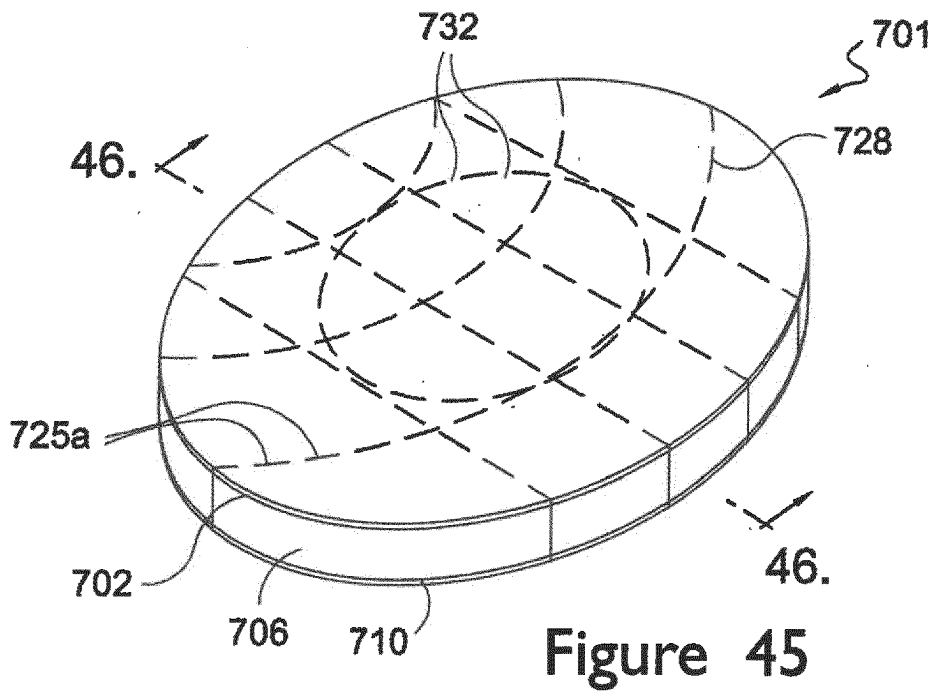

Figure 38







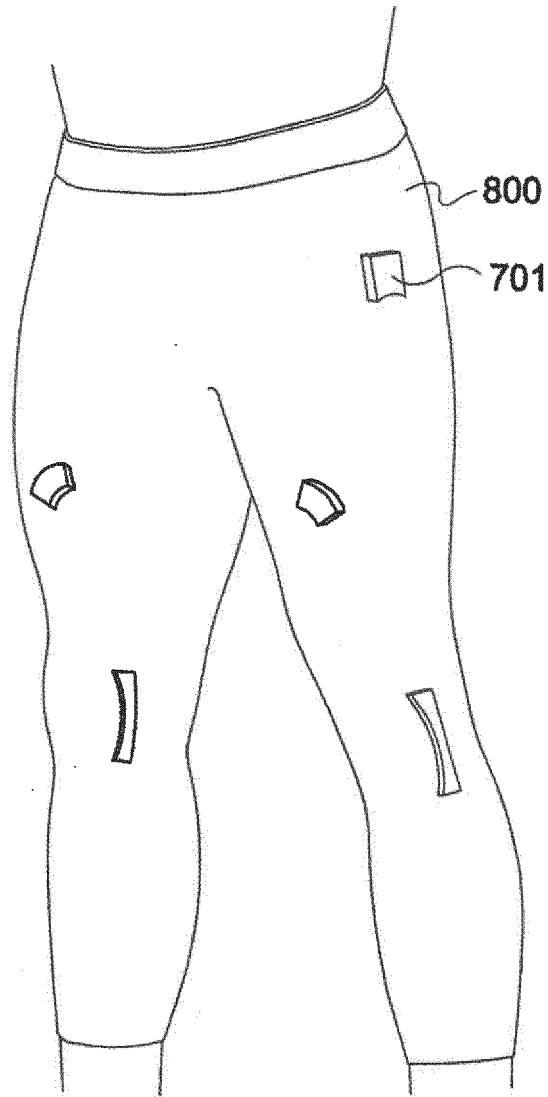

Figure 47



Figure 48

REFERENCES CITED IN THE DESCRIPTION

This list of references cited by the applicant is for the reader's convenience only. It does not form part of the European patent document. Even though great care has been taken in compiling the references, errors or omissions cannot be excluded and the EPO disclaims all liability in this regard.

Patent documents cited in the description

- US 2015096659 A1 [0002]
- US 2008189830 A1 [0003]
- US 2010024089 A1 [0004]
- US 2017196277 A1 [0005]