

(No Model.)

2 Sheets—Sheet 1.

E. M. POPE.
RIVET SETTING MACHINE.

No. 523,730.

Patented July 31, 1894.

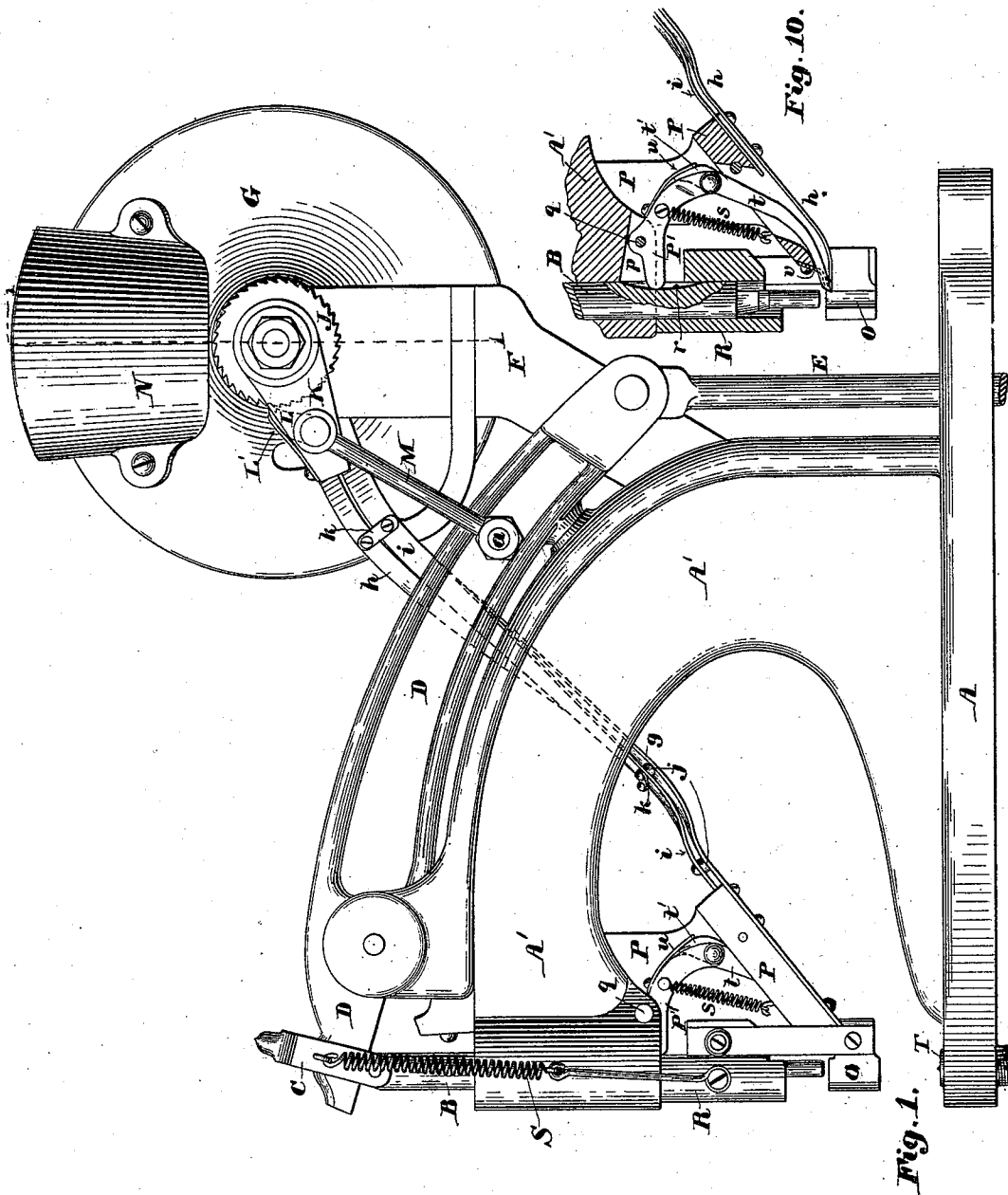

Witnesses:
Walter E. Lombard,
Marshall Underwood

Inventor:
Everett M. Pope,
by N. P. Lombard
Attorney.

E. M. POPE.
RIVET SETTING MACHINE.

No. 523,730.

Patented July 31, 1894.

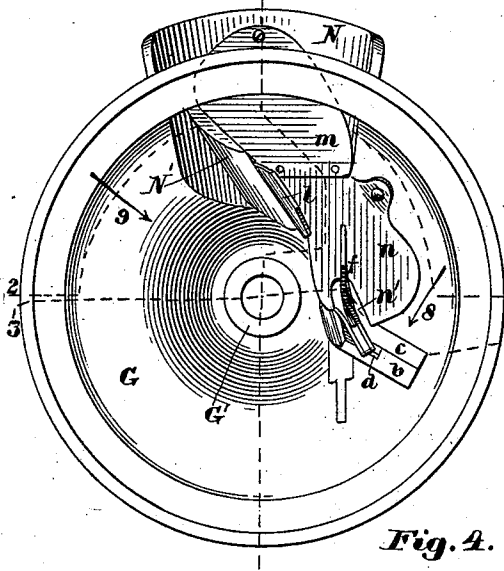

Fig. 4.

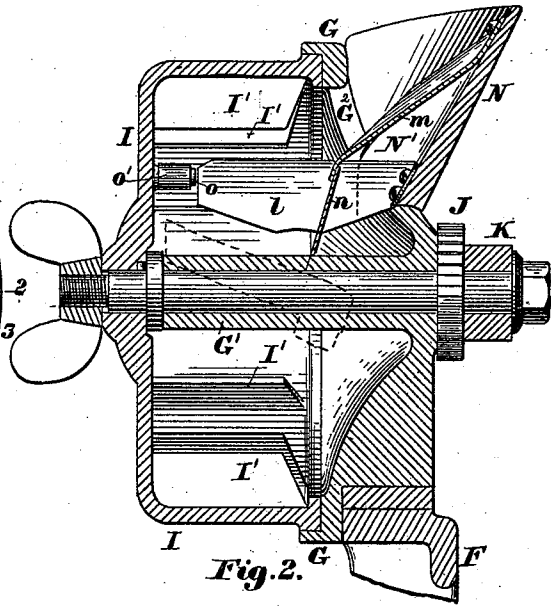

Fig. 2.

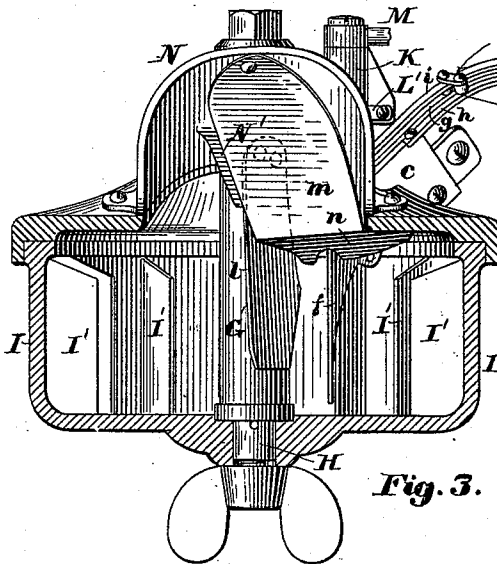

Fig. 3.

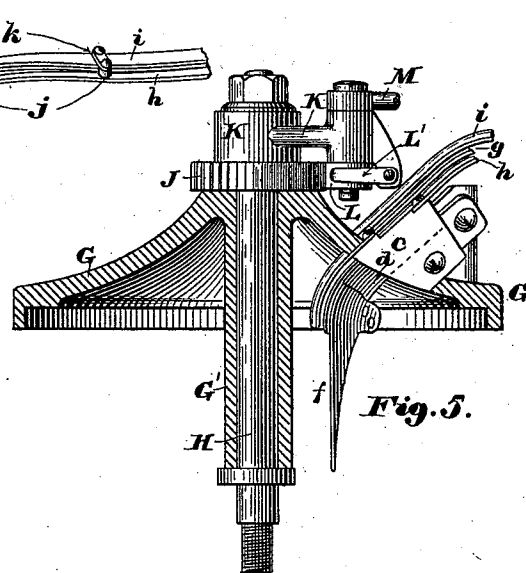

Fig. 5.

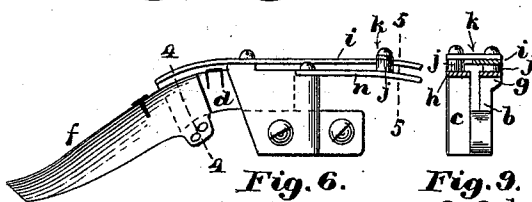

Fig. 6.

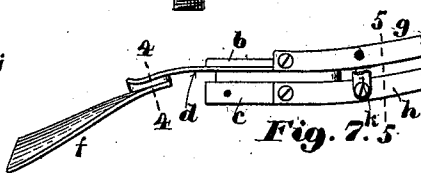

Fig. 7.

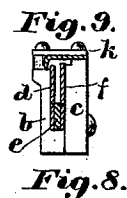

Fig. 8.

Witnesses:
Walter E. Lombard
Marshall Underwood

Inventor:
Everett M. Pope,
by N. G. Lombard
Attorney.

UNITED STATES PATENT OFFICE.

EVERETT M. POPE, OF QUINCY, ASSIGNOR TO MELLEN N. BRAY, OF BOSTON, MASSACHUSETTS.

RIVET-SETTING MACHINE.

SPECIFICATION forming part of Letters Patent No. 523,730, dated July 31, 1894.

Application filed March 19, 1894. Serial No. 504,145. (No model.)

To all whom it may concern:

Be it known that I, EVERETT M. POPE, of Quincy, in the county of Norfolk and State of Massachusetts, have invented certain new and useful Improvements in Rivet-Setting Machines, of which the following, taken in connection with the accompanying drawings, is a specification.

My invention relates to rivet setting machines, is particularly designed for setting rivets having two prongs, is an improvement upon the invention described in the Letters Patent No. 509,554 granted to me November 28, 1893, and it consists in certain novel features of construction, arrangement and combination of parts which will be readily understood by reference to the description of the accompanying drawings, and to the claims hereto appended and in which my invention is clearly pointed out.

Figure 1 of the drawings is a side elevation of a rivet setting machine embodying my invention. Fig. 2 is a sectional elevation of the hopper the cutting plane being on line 1, 1, on Fig. 1. Fig. 3 is a sectional plan of the hopper and a portion of the rivet raceway the cutting plane being on line 2, 2, on Fig. 4, through the hopper, but showing the funnel through which the rivets are inserted into the hopper, and the shields and guards for directing the rivets when they fall from the radial shelves of the revolving portion of the hopper in full line plan notwithstanding said parts are above said line 2, 2. Fig. 4 is an elevation of the inside of the fixed side of the hopper, and the rivet inserting funnel and the guards and shields, with the revolving portion of the hopper removed. Fig. 5 is a horizontal section through the fixed side of the hopper on line 3, 3, on Fig. 4, and showing the ratchet mechanism for operating the revolving portion of the hopper, and a portion of the guide or raceway in plan. Fig. 6 is a view of the upper portion of the raceway as seen when looking in the direction indicated by the arrow 8 on Fig. 4. Fig. 7 is a view of the same parts except the guard plate as seen when looking in the direction indicated by the arrow 9 on Fig. 4. Fig. 8 is a transverse section of the raceway on line 4, 4, on Figs. 6 and 7 looking toward the right

of said figure. Fig. 9 is a similar section on line 5, 5, on Figs. 6 and 7 looking toward the left. Fig. 10, is a sectional elevation of a portion of the goose-neck, the setting plunger and the mechanism for separating the lower rivet in the raceway from those above it and feeding it into the pocket.

In the drawings A is the base of the head of the machine having formed in one piece therewith the goose-neck A', in the front end of which is mounted the setting plunger B connected at its upper end, by the link C, to the short arm of the lever D, the long arm of which is connected by the rod E to a suitable treadle (not shown) by which said lever may be vibrated in a well known manner.

F is a stand secured to the goose neck A' near its rear end and having secured thereto, or formed in one piece therewith, the disk G which forms the fixed side of a rivet containing hopper and is provided with the central hub G' in a bearing in which is mounted the shaft H upon one end of which is detachably secured the revolving portion I of the hopper, and upon its other end the ratchet wheel J.

The hopper I is provided with a series of ribs or shelves I' which extend inward from its wall toward its axis and longitudinally thereof or parallel with its axis of revolution substantially as in my before cited prior patent.

The shaft H has loosely mounted thereon in close proximity to the ratchet wheel J the arm K to the movable end of which is pivoted the pawl L in position to engage the teeth of the ratchet wheel J against which it is pressed by the spring L'. The arm K also has pivoted thereto the upper end of the link M the opposite end of which is pivoted to the lever D at a.

The disk G has an opening cut through it at G² and has secured thereto, so as to inclose said opening, the funnel N through which and said opening the hopper may be charged with rivets substantially as in the patent before cited. The disk or hopper head G also has another opening at the left of and below the center thereof to receive the blocks b and c which are secured together and to said disk or head and form supports for the several plates or bars which form the raceway down

which the rivets slide to the setting tools. The blocks *b* and *c* are arranged with their broader sides at an angle of about thirty degrees to a horizontal line as viewed in a direction parallel to the axis of motion of the hopper I and said blocks are secured together at their lower portions while their upper portions are separated from each other by a space sufficiently wide for the passage of the prongs of the rivets between them as shown in Figs. 8 and 9.

The inner face of the block *b* has secured thereto one end of a short plate *d* with its broader sides parallel to the broader sides of the blocks *b* and *c*, and its upper edge coinciding with the upper edge of said block *b*, said plate *d* projecting into the hopper beyond the inner faces of the blocks *b* and *c* a short distance and being curved as shown in Fig. 7. The inner end of said plate *d* has formed upon or secured to its side at its lower edge a boss or small plate *e* to which is also secured the lower end of the plate *f* which overlaps the inner end of the plate *d* and projects into the hopper nearly to its revolving head as indicated in dotted lines in Fig. 2.

The plate *f* is twisted so that while the end which is attached to the plate *d* lies at an angle to a horizontal line of about thirty degrees its opposite end is perpendicular, while its upper edge is inclined as indicated in dotted line in Fig. 2.

The block *b* also has secured to its upper edge the upper end of the plate *g* with its upper inner corner coinciding with the upper inner corner of the plate *d* and arranged with its broader sides at right angles to the broader sides of said plate *d*, said plate or bar *g* extending downward in a curved and inclined direction to or nearly to the pocket O and has its lower end secured to the under side of the stand P secured to and pendent from the goose-neck A' as shown in Figs. 1 and 2.

The upper edge of the block *c* has secured thereto the upper end of a plate or bar *h* corresponding to *g* and parallel thereto and secured in like manner to the stand P with a uniform space between said plates *g* and *h* so that they together form the raceway down which the rivets slide from the hopper to the setting tools.

Above the plate *g*, and secured thereto, is a guard plate *i* of greater width than the plate *g* which is maintained at a suitable distance from said plate *g* by collars or thimbles *j* placed between said plates at intervals as shown in Figs. 1, 3, and 6.

The plates *g* and *h* are held at a uniform distance apart by the tie plates *k* secured thereto above the thimbles *j* as shown in Figs. 1, 3, 6, 7, 8, and 9.

The funnel N has formed upon or secured to its inner surface an inwardly projecting ear N' to which is secured the sheet metal plate *l*, which projects nearly to the rotating head of the hopper and is inclined as shown in Figs. 3, and 4, so that the rivets as they are

discharged from the shelves or buckets I' of the hopper, as it is revolved, and fall upon said plate *l*, will be directed toward the upper edge of the plate *f* upon which more or less of them will fall astride and slide down its inclined edge until one of its prongs comes in contact with the outwardly curved end portion of the plate *d* when the frictional contact therewith of said prong will partially turn the rivet about its axis about one sixteenth more or less of a revolution in which position it continues to descend until the end of the plate *f* when the force of gravity acting upon said rivet causes it to fall upon the plate *d* with both prongs of said rivet upon the upper side of said plate as shown in Fig. 6.

The funnel N also has secured therein the bent and inclined plate *m* to the lower edge of which and the inner surface of the disk G is secured the plate *n* provided in its lower end with a slot or notch *n'* to allow the passage of the rivets down the inclined edge of the plate *f* while the plate *n* extends some distance below the upper edge of said plate *f* upon each side thereof, the office of the plates *m* and *n* being to direct the rivets, when being placed in the hopper, or when they fall from the shelves I', away from the stationary head G, and well into the revolving portion I of the hopper.

The hopper I has set in its head a stud *o* carrying a roll *o'* so located that at each revolution of said hopper the roll *o'* will come in contact with the free or unattached end of the plate *f* and spring it sufficiently for said roll to pass it thus agitating said plate to insure the sliding of the rivets down its inclined edge and their discharge from its lower end upon the plate *d*.

The front end of the goose neck A' has formed in its underside at the rear of the setting plunger a slot *p* in which is mounted upon the fulcrum pin *q* the lever P' the short arm of which projects into, and is acted upon by the curved bottom of, the slot *r*, formed in the rear side of the setting plunger B so that when the plunger is moved downward to set a rivet the short arm of the lever P' will be moved downward against the tension of the coiled spring *s* one end of which is attached to the long arm of said lever and the other end to the stand P.

The end of the long arm of the lever P' is forked and has pivoted in said fork the pawl *t* having a short arm *t'* which projects above pivot of said pawl and is pressed upon by the spring *u* secured to the lever P' so as to tend to press the lower end of the pawl upon or toward the upper surfaces of the plates *g* and *h* so that, when said pawl is moved toward the pocket its point will engage the lowest rivet in the line and move it into the pocket O while the other rivets in the line are held back behind the point of said pawl.

When the plunger descends to set the rivet deposited in the pocket the upper portion of the slot *r* in said plunger acting upon the le-

ver P' causes the point of the pawl *t* to recede or be moved backward over the next rivet in the line which is prevented from being displaced or thrown out of the raceway
 5 by the spring or guard plate *v* which is forked to permit the free passage of the end of the pawl which is made of less width than the diameter of the rivet head. The pocket O, its carrier R, the spring S and the anvil T are
 10 constructed and operate substantially as in my prior patent before cited.

The operation of my invention will be readily understood from the foregoing without further description here.

15 What I claim as new, and desire to secure by Letters Patent of the United States, is—

1. In a machine for setting pronged rivets the combination with a revolving hopper provided with a series of inwardly projecting
 20 shelves adapted to carry a quantity of the rivets above the level of the axis of said hopper and then discharge them toward the center of the hopper; a raceway extending from said hopper to the pocket beneath the setting
 25 plunger and composed of two parallel plates or bars arranged with a space between them for the passage of the rivet prongs one in advance of the other while the projecting portions of the rivet heads rest upon said plates;
 30 an extension of one of said plates projecting a short distance into said hopper and having its broader side inclined transversely to a horizontal plane; a guard plate arranged above said rivet guiding plates; and a rivet
 35 receiving plate connected to and overlapping the inner end of said extension and projecting beyond the same nearly to the opposite head of the hopper with its upper edge inclined longitudinally and separated from said
 40 extension as set forth.

2. In a machine for setting pronged rivets, the combination with a fixed hopper head, a

revolving cylindrical hopper provided with longitudinal shelves projecting inward from its cylindrical wall and mechanism having
 45 provision for intermittently rotating said hopper, of a thin plate supported in a fixed position within said hopper by its lower end with the upper portions of its broader sides vertical or nearly so and adapted to receive the
 50 rivets astride thereof; and a raceway or chute composed of the plates *d*, *g*, *h* and *i* arranged relative to each other and the rivet receiving plate as set forth.

3. The combination of the hopper G I; the
 55 funnel N; the rivet receiving plate *f*; the rivet guiding plate *l* extending into said hopper from its front side, and inclined transversely toward the plate *f*; the plates *m* and
 60 *n* supported by said funnel and inclined toward the center of said hopper and arranged relative to each other and to the plates *l* and *f* as set forth the raceway composed of the plates *g*, *h*, arranged parallel to each other
 65 with a space between them and their upper surfaces in the same inclined plane, and the plate *i* arranged above and parallel to the plates *g*, *h*, and partially overlapping the space between the plates *g*, *h*, said plates *g*, *h*, and *i*,
 70 extending from the hopper to the rivet receiving pocket; and the plate *d* forming an extension of the raceway plate *g*, and connected at its inner end to the lower end of the plate *f*, all constructed, arranged and operating substantially as described. 75

In testimony whereof I have signed my name to this specification, in the presence of two subscribing witnesses, on this 16th day of March, A. D. 1894.

EVERETT M. POPE.

Witnesses:

N. C. LOMBARD,
 F. A. HOWE.