

627270

COMMONWEALTH OF AUSTRALIA

PATENT ACT 1952

APPLICATION FOR A STANDARD PATENT

H-C Industries, Inc., of 1201 East Elmore Street, Crawfordsville, Indiana, 47933, UNITED STATES OF AMERICA, hereby apply for the grant of a standard patent for an invention entitled:

Tamper-Indicating Plastic Closure

which is described in the accompanying complete specification.

Details of basic application(s):-

<u>Basic Applic. No:</u>	<u>Country:</u>	<u>Application Date:</u>
303,317	US	30 January 1989
343,995	US	26 April 1989
465,301	US	23 January 1990

The address for service is:-

Spruson & Ferguson
Patent Attorneys
Level 33 St Martins Tower
31 Market Street
Sydney New South Wales Australia

DATED this THIRTIETH day of JANUARY 1990

H-C Industries, inc.

By:

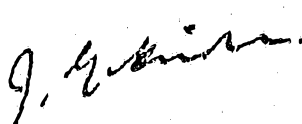
Registered Patent Attorney

TO: THE COMMISSIONER OF PATENTS
OUR REF: 119919
S&F CODE: 53520

6012764 30/01/90
5845/5

COMMONWEALTH OF AUSTRALIA

PATENTS ACT 1952

DECLARATION IN SUPPORT OF A CONVENTION APPLICATION FOR A PATENT

In support of the Convention Application made for a patent for an invention entitled:

Tamper-Indicating Plastic Closure

I, Charles B. Schiele, President, of H-C Industries, Inc., 1201 East Elmore Street, Crawfordsville, Indiana 47933, United States of America do solemnly and sincerely declare as follows:-

1. I am authorised by H-C Industries, Inc., the applicant for the patent to make this declaration on its behalf.
2. The basic applications as defined by Section 141 of the Act were made in United States of America on 30 January, 1989 by SHELDON W. WIDE, on 26 April, 1989 by STEPHEN W. McBRIDE and on 23 January, 1990 by STEPHEN W. McBRIDE.
3. STEPHEN W. McBRIDE and SHELDON L. WILDE, of 613 Nelson Drive, Brownsburge, Indiana 46112 and 1309 Durham Drive, Crawfordsville, Indiana 47933, both in the United States of America [respectively], are the actual inventors of the invention and the facts upon which the applicant is entitled to make the application are as follows:

The said applicant is the assignee of the actual inventors.
4. The basic applications referred to in paragraph 2 of this Declaration were the first applications made in a Convention country in respect of the inventions the subject of the application.

DECLARED at 11:30 AM this 17TH day of May 1990

.....
Signature of Declarant

TO: THE COMMISSIONER OF PATENTS
AUSTRALIA

Ref: S&F 1978D

SBR/JS/1978D

(12) PATENT ABRIDGMENT (11) Document No. AU-B-48910/90
(19) AUSTRALIAN PATENT OFFICE (10) Acceptance No. 627270

- (54) Title
TAMPER-INDICATING PLASTIC CLOSURE
- International Patent Classification(s)
(51)⁴ B65D 055/06 B65D 041/34
- (21) Application No. : 48910/90 (22) Application Date : 30.01.90
- (30) Priority Data
- | (31) Number | (32) Date | (33) Country |
|-------------|-----------|-----------------------------|
| 303317 | 30.01.89 | US UNITED STATES OF AMERICA |
| 343995 | 26.04.89 | US UNITED STATES OF AMERICA |
| 465301 | 23.01.90 | US UNITED STATES OF AMERICA |
- (43) Publication Date : 02.08.90
- (44) Publication Date of Accepted Application : 20.09.92
- (71) Applicant(s)
H-C INDUSTRIES INC.
- (72) Inventor(s)
STEPHEN W MCBRIDE; SHELDON L. WILDE
- (74) Attorney or Agent
SPRUSON & FERGUSON, GPO Box 3398, SYDNEY NSW 2001
- (56) Prior Art Documents
US 4848614
AU 598641 12178/88 B65D 55/02 41/34
US 4635808
- (57)

A tamper-indicating plastic closure is disclosed, with the closure configured for interfering coaction with an associated container. The closure includes a plastic cap having a top wall portion and an internally threaded annular skirt portion, with an annular pilfer band depending therefrom. The pilfer band includes a plurality of circumferentially spaced flexible tabs configured for interfering engagement with an annular locking ring portion of the associated container. The pilfer band further includes an annular interference bead positioned beneath the flexible tabs. By this arrangement, two modes of interfering engagement with the associated container locking ring are provided. In an alternate embodiment, the pilfer band includes an angularly skewed interference lip and centering ribs.

CLAIM

1. A tamper-indicating plastic closure for a container having an annular locking ring, said closure comprising:
a plastic cap having a top wall portion, and an annular, depending cylindrical skirt portion; and
an annular pilfer band depending from said skirt portion and at

(11) AU-B-48919/90
(10) 627270

-2-

least partially detachably connected thereto by frangible rib means,
said pilfer band including an annular band portion, a plurality of circumferentially spaced, inwardly extending flexible tab means, and an annular interference bead positioned beneath said flexible tab means and extending inwardly of the bottom edge of said annular band portion;

said flexible tab means being engageable with said container locking ring: (1) when said flexible tab means extend generally angularly upwardly and inwardly of said annular band portion for fracturing said frangible rib means, and (2) when said flexible tab means extend generally angularly downwardly and inwardly of said annular band and are disposed between said annular locking ring and said interference bead for fracturing said frangible rib means.

10. A tamper-indicating plastic closure for a container having an annular locking ring, said closure comprising:

a closure cap including a circular top wall portion and a depending, generally cylindrical skirt portion having an internal thread formation;

an annular pilfer band depending from said cylindrical skirt portion;

frangible rib means at least partially detachably connecting said pilfer band to said skirt portion, said frangible rib means comprising a plurality of spaced apart frangible ribs;

said pilfer band including interference means on the inside surface of said pilfer band, said interference means being engageable with the locking ring of said container during removal of said closure therefrom for fracturing said frangible ribs, said pilfer band further including centering means engageable with the locking ring of said container during removal of said closure therefrom for maintaining said pilfer band in a circular configuration.

627270

S & F Ref: 119919

FORM 10

COMMONWEALTH OF AUSTRALIA

PATENTS ACT 1952

COMPLETE SPECIFICATION

(ORIGINAL)

FOR OFFICE USE:

Class Int Class

Complete Specification Lodged:
Accepted:
Published:

Priority:

Related Art:

Name and Address
of Applicant:

H-C Industries, Inc.
1201 East Elmore Street
Crawfordsville Indiana 47933
UNITED STATES OF AMERICA

Address for Service:

Spruson & Ferguson, Patent Attorneys
Level 33 St Martins Tower, 31 Market Street
Sydney, New South Wales, 2000, Australia

Complete Specification for the invention entitled:

Tamper-Indicating Plastic Closure

The following statement is a full description of this invention, including the best method of performing it known to me/us

5845/6

ABSTRACT

A tamper-indicating plastic closure is disclosed, with the closure configured for interfering coaction with an associated container. The closure includes a plastic cap having a top wall portion and an internally threaded annular skirt portion, with an annular pilfer band depending therefrom. The pilfer band includes a plurality of circumferentially spaced flexible tabs configured for interfering engagement with an annular locking ring portion of the associated container. The pilfer band further includes an annular interference bead positioned beneath the flexible tabs. By this arrangement, two modes of interfering engagement with the associated container locking ring are provided. In an alternate embodiment, the pilfer band includes an angularly skewed interference lip and centering ribs.

5

10

15

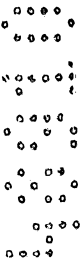

TAMPER-INDICATING PLASTIC CLOSURE

Cross-Reference To Related Application

This application is a continuation-in-part of
U.S. patent application Serial No. 07/343,995, filed
5 April 26, 1989.

Technical Field

The present invention relates generally to
tamper-indicating or tamper evident packaging
arrangements, and more particularly to a tamper-
10 indicating plastic closure for a container which
functions to provide two modes of interference with the
container for enhanced tamper resistance.

Background Of The Invention

The provision of tamper-indicating or tamper-
evident closures for containers is desirable for all
manner of consumer products, so that partial or complete
removal of the closure results in clearly discernable
visible alteration thereof. Typically, closures of this
nature include an upper cap portion, and a depending
20 pilfer band arranged to interact and cooperate with the
container to which the closure is applied. The pilfer
band is typically configured so as to fracture and/or
separate from the closure cap attendant to closure
removal, thereby providing clearly discernable evidence
25 that the container has been partially or completely
opened.

As will be appreciated, it is desirable for a
tamper-indicating closure to be as resistant as possible
to tampering or the like without visibly discernable
evidence thereof. To this end, the present plastic
closure has been particularly configured for economical
and efficient manufacture for use on existing
30 containers, with the closure being highly resistant to
tampering, consistent and reliable in performance, and

There is further disclosed herein a tamper-indicating plastic closure for a container having an annular locking ring, said closure comprising:

5 a closure cap including a circular top wall portion and a depending, generally cylindrical skirt portion having an internal thread formation;

an annular pilfer band depending from said cylindrical skirt portion;

10 frangible rib means at least partially detachably connecting said pilfer band to said skirt portion, said frangible rib means comprising a plurality of spaced apart frangible ribs;

15 said pilfer band including interference means on the inside surface of said pilfer band, said interference means being engageable with the locking ring of said container during removal of said closure therefrom for fracturing said frangible ribs, said pilfer band further including centering means engageable with the locking ring of said container during removal of said closure therefrom for maintaining said pilfer band in a circular configuration.

5
5
5

5
5
5

5
5
5



BRIEF DESCRIPTION OF THE DRAWINGS

A preferred form of the present invention will now be described by way of example with reference to the accompanying drawings, wherein:

5 FIGURE 1 is a side elevational view, in partial cross-section, of a tamper-indicating plastic closure embodying the principles of the present invention applied to an associated container;

FIGURE 2 is a cross-sectional view of the novel tamper-indicating closure;

10 FIGURE 3 is a fragmentary, side-elevational view, in partial cross-section illustrating application of the novel closure to the associated container;

FIGURE 4 is a view similar to FIGURE 3 illustrating the closure after application to the associated container, and in a position for providing a first mode of interfering engagement with the container;

15 FIGURE 5 is a view similar to FIGURE 4, illustrating the closure in position for effecting a second mode of interfering engagement with the associated container;

20 FIGURES 6a and 6b are views similar to FIGURE 5, further illustrating the second mode of interfering engagement of the closure with the associated container;

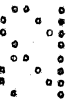
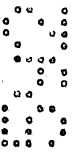
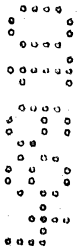

FIGURE 7 is a fragmentary, cross-sectional view of a further embodiment of the present tamper-indicating plastic closure; and

FIGURE 8 is a view similar to FIGURE 7 illustrating another embodiment of the present tamper-indicating closure.

5 FIGURE 9 illustrates a further embodiment of a tamper-indicating closure;

FIGURE 10 is a cross-sectional view of the closure illustrated in FIGURE 9; and

10 FIGURE 11 is a fragmentary, cross-sectional view taken along lines 11-11 of FIGURE 10.

SECRET



Detailed Description

5 While the present invention is susceptible of embodiment in various forms, there is shown in the drawings and will hereinafter be described a presently preferred embodiment, with the understanding that the present disclosure is to be considered as an exemplification of the invention, and is not intended to limit the invention to the specific embodiment illustrated.

10 With reference first to FIGURE 1, therein is illustrated a plastic closure 10 embodying the principles of the present invention. Closure 10 can be made by various injection-molding or compression-molding techniques, and it can be formed in accordance with the compression-molding techniques taught in U.S. Patent No. 4,497,765, which is incorporated herein by reference.

15 As illustrated, closure 10 includes an upper generally cup-shaped closure cap 12 including a circular top wall portion 14, and a depending, annular cylindrical skirt portion 16. Skirt portion 16 preferably includes an internal thread formation 18 configured for threading engagement in cooperation with the threads T of an associated container C to which the closure is fitted. If desired, the plastic closure can be provided with an associated sealing liner, such as illustrated in the above-referenced patent.

20 The present closure further includes an annular pilfer band 20 depending from and at least partially detachably connected to skirt portion 16 of the closure cap. Pilfer band 20 preferably comprises a continuous annular band portion 22 arranged in substantial vertical alignment with skirt portion 16. In the preferred embodiment, the pilfer band is at least partially detachably connected to the skirt portion by a plurality of circumferentially spaced frangible ribs 24

25

30

35

which extend between the inside surfaces of the skirt portion 16 and the band portion 22 of the pilfer band. As shown, the pilfer band 20 is otherwise distinguished and separated from the skirt portion 16 by a circumferentially extending score line 26.

5

In accordance with the teachings of U.S. Patent No. 4,418,828, incorporated herein by reference, score line 26 and frangible rib 24 together cooperate to provide the desired frangible connection between the pilfer band 20 and the closure cap 12. Specifically, the closure cap 12 and the pilfer band 20 are formed integrally with each other during molding, with the ribs 24 molded on the inside surfaces of the skirt portion and pilfer band. Thereafter, score line 26 is formed, preferably by use of a scoring cutting blade, thereby distinguishing and separating the pilfer band 20 from the skirt portion 16, with the score line 26 extending partially into the ribs 24.

10

15

By this arrangement, the unscored, "residual" portions of the frangible ribs 24 collectively provide the desired frangible connection between the pilfer band and the skirt portion. If desired, an integral connector portion can be provided between the pilfer band and the skirt portion (such as by leaving a portion of the closure uncut by score line 26) whereby the pilfer band remains connected to the skirt portion 16 after fracture of the ribs. In conjunction with such a connector portion, one or more fracturable areas can be provided in the pilfer band itself, whereby the pilfer band splits and fractures during closure removal from the associated container.

20

25

30

Referring now to the configuration of the pilfer band 20, the present closure has been specifically configured to provide a very high degree of tamper resistance, and in particular provides two

35

distinct and separate modes of interfering interaction with the associated container. To this end, the pilfer band includes a plurality of circumferentially spaced, inwardly extending flexible tabs 28 which extend
5 inwardly from the annular band portion 22 of the pilfer band. In a current embodiment, twelve evenly spaced tabs 28 are provided about the circumference of the pilfer band, with each tab having a width of about 0.240 inches, and a thickness of between about 0.012 inches and 0.020 inches. By this arrangement, the free end portions of adjacent ones of the tabs 28 are closely spaced (about 0.020 inch spacing) when the tabs extend horizontally inwardly. This horizontally inwardly extending orientation of the tabs is indicated in phantom line, and represents the orientation in which
10 the flexible tabs 28 are preferably molded.

As will be further described, the flexible tabs 28 cooperate with an annular locking ring portion L of container C for effecting fracture of frangible ribs 24, thereby providing the desired tamper-indication. In
15 a first mode of interference and failure, the free end portions of the flexible tabs are engageable with the locking ring L. In a second mode of failure, the flexible tabs are configured to cooperate with an annular interference bead 30 provided generally at the lower edge of annular band portion 22 of the pilfer band
20 20. To this end, the interference bead 30 is positioned beneath the flexible tabs 28, with the upper, inward edge portion of the interference bead positioned relative to the flexible tabs so that this edge portion is engaged by the tabs in the second failure mode. In the preferred form, the inside diameter of the interference bead is about equal to or slightly less than an inside diameter collectively defined by the
25 30

inside surfaces of the circumferentially spaced frangible ribs 24.

Referring now to FIGURE 3, the function of the present closure will be described. During application of the closure 10 to the associated container, the flexible tabs 28 engage the container C and are moved upwardly generally to an upwardly extending, out-of-the-way disposition as the pilfer band moves downwardly relative to the container threads T and the container locking ring L. To this end, the flexible tabs 28 are preferably provided with a thickness about equal to the radial dimension of the frangible ribs 24, or the tabs 28 are otherwise configured to collectively define an inside diameter about equal to an inside diameter collectively defined by the ribs 24.

When the closure is fully seated on the container, the flexible tabs 28 have moved past the container locking ring L, and thereafter, due to the resilient memory of the plastic, assume a generally angularly upwardly and inwardly extending disposition, as illustrated in FIGURE 4. The flexible tabs 28 are now in position for the first mode of interfering interaction and failure in cooperation with the container locking ring. Specifically, unscrewing upward movement of the closure 10 relative to the container urges the generally upwardly extending flexible tabs 28 into and against the container locking ring L. This interfering engagement with the container locking ring acts to resist the upward unscrewing movement of the closure, thereby stressing and fracturing the frangible ribs 24. Fracture of the ribs 24 results in clearly visibly discernable separation of the pilfer band 20 from the skirt portion 16, thus providing a clear indication of opening of the container.

In a current embodiment, each flexible tab 28 is of a generally planar configuration, having a thickness dimensioned between about 0.012 inches and 0.020 inches. However, as will be appreciated, each flexible tab 28 is preferably dimensioned and configured for sufficient thickness, in the direction from its free end to its base integral with the band portion 22, so as to exhibit sufficient resistance to collapse or deformation to thereby provide the desired interfering interaction with locking band L. To this end, each of the tabs 28 may be of a non-planar configuration, such as being slightly curved when viewed in cross-section perpendicular to the length of each tab, or similarly, of a generally angled or compound configuration when similarly viewed. As will be appreciated, such arrangements can act to enhance the "column strength" of each flexible tab for providing the desired interfering engagement with locking ring L.

In accordance with the present invention, the flexible tabs 28 are configured for cooperation with interference bead 30 to provide a second and distinct mode of interfering engagement with the container locking ring L. In the event that the flexible tabs 28 are moved from their angularly upwardly and inwardly disposition (such as by unauthorized manipulation or the like, which is desirably inhibited by the inwardly extending bead 30) the flexible tabs will assume an angularly downwardly and inwardly extending disposition, as illustrated in FIGURE 5. In this orientation of the tabs, the tabs are positioned for engagement with the container locking ring L by disposition between the container locking ring and the upper inward edge of the interference bead 30. In this manner, the tabs cooperate and coact with the interference bead to again provide interfering interaction with the container

locking ring, to thereby fracture frangible ribs 24 for at least partially detaching the pilfer band 20 from the skirt portion 16. This action is illustrated in FIGURES 6a and 6b, where in FIGURE 6a, a flexible tab 28 is illustrated between the locking ring L and the interference bead 30, with FIGURE 6b illustrating the subsequent failure of frangible rib 24 and separation along score line 36.

Referring now to FIGURE 7, therein is illustrated an alternate embodiment of the present tamper-indicating closure. In most respects, this embodiment is the same as the previously described embodiment, although it will be noted that the closure illustrated in FIGURE 7 shows the provision of a sealing liner 15 adjacent to top wall portion 14, and a vent groove 17 traversing the internal thread formation 18, with the vent groove 17 extending into the cylindrical skirt portion 16 of the closure. The provision of one or more vent grooves 17 facilitates venting of gas pressure, attendant to closure removal, when the present closure is used in connection with a container having carbonated contents or the like.

As in the previous embodiment, the closure 10 includes a pilfer band 20 which is distinguished and at least partially separated from the skirt portion 16 by a circumferential score 26. Moreover, the pilfer band 20 includes a plurality (twelve being presently preferred) of circumferentially spaced, inwardly extending flexible tabs 28, again configured to provide a dual mode of interference with the locking ring of an associated container. To this end, an inwardly extending interference bead 30 is positioned beneath the flexible tabs 28, with the tabs 28 being engageable with the interference bead 30 in the second mode of interaction of the closure with an associated container.

In this embodiment, the frangible connection between the pilfer band 20 and the skirt portion 16 is provided by a plurality of circumferentially spaced, frangible ribs 124 which extend between the inside surfaces of the skirt portion and the pilfer band. Significantly, at least some of the frangible ribs 124 extend on the inside surface of the band portion 22 of the pilfer band 20 between adjacent ones of the flexible tabs 28. In the illustrated embodiment, each of the illustrated frangible ribs 124 is so configured.

This configuration of the frangible ribs 124 desirably acts to center the pilfer band 20 on the associated container C with respect to the container locking ring L. By virtue of this configuration of the frangible ribs 124, a very limited amount of clearance is provided between the container locking ring L and the inwardly facing surfaces of the frangible ribs 124 when the closure 10 is fully seated on the associated container. This desirably acts to enhance tamper-resistance since the frangible ribs 124 thus act to prevent deformation of the pilfer band to an out-of-round configuration, thus substantially precluding removal of the pilfer band from the associated container without attendant fracture of the frangible ribs 124. Like the frangible ribs 24 of the previous embodiment, ribs 124 are rendered fracturable by virtue of the score line 26 partially extending into at least some of the ribs.

In the embodiment of FIGURE 7, an arrangement is provided to facilitate efficient and accurate formation of the score line 26. Specifically, this embodiment includes a circumferentially extending scoring bead 127 on the inside of the closure, with the scoring bead 127 preferably extending continuously along

5

10
15

20

25

30

the inside of the closure, and with circumferential score line 26 positioned beneath the scoring bead.

5 During scoring of the present closure, a scoring mandrel inserted into the closure is preferably employed, with a scoring knife or the like then applied to the exterior surface of the closure. For high-speed manufacture, it is presently preferred that position of the scoring knife be referenced relative to the interiorly-positioned scoring mandrel.

10 Accordingly, it is desirable to have the closure remain in a substantially fixed position on the scoring mandrel, without excessive deformation or deflection during scoring. Otherwise, inaccurate scoring may result.

15 Thus, the scoring bead 127 is configured to securely engage and seat against the scoring mandrel, whereby highly efficient and accurate formation of the score line 26, with the desired degree of partial cutting of the frangible ribs 124, is readily accomplished.

20 As in the previous embodiment, the flexible tabs 28 are preferably provided with a thickness about equal to the radial dimension of frangible ribs 124. This preferred dimensional relation permits the tabs 28 to desirably support the interior of the closure during scoring (when the tabs 28 are flexed upwardly against the inside surface of the closure) in absence of the scoring bead 127.

25 Efficient and accurate scoring is further facilitated by the disposition of the frangible ribs 124 between adjacent ones of the tabs 128. By this arrangement, any possible overlap of one of the tabs 128 with an adjacent frangible rib (such as by deformation and elongation of a flexible tab attendant to ejection from its molding apparatus) is avoided. Additionally,

30

35

this extended configuration of the frangible ribs 124 permits the score line 26 to be positioned relatively close to the bottom edge of the pilfer band 20, which has been found to desirably enhance the tamper-resistance of the present closure, since any unauthorized manipulation or other tampering is more likely to result in fracture of one or more of the frangible ribs 124.

A further feature of the embodiment of FIGURE 7 concerns the formation of each of the frangible ribs 124 with an upper portion 125 which extends on the inside surface of skirt portion 16 above scoring bead 127. This configuration of the frangible ribs has been found to desirably enhance the columnar strength of the overall closure, which facilitates high-speed ejection from the associated molding apparatus.

Referring now to FIGURE 8, therein is illustrated a further alternate embodiment of the present closure. In most respects, this embodiment is like that described above and illustrated in FIGURE 7, although the embodiment of Figure 8 does not include a scoring bead 127. The absence of the scoring bead, together with the extended configuration of frangible ribs 124 (with upper portions 125) can enhance the gas venting characteristics of the closure.

Two additional features of the embodiment of FIGURE 8 should be noted. First, this embodiment of the present tamper-indicating closure includes an arrangement for prestressing the frangible connection between the pilfer band 20 and the skirt portion 16 provided by the frangible ribs 124. Specifically, a plurality of circumferentially spaced, prestressing projections 131 are provided on the inside surface of the band portion 20 of the pilfer band. In the illustrated embodiment, and in accordance with the

preferred configuration, these prestressing projections 131 are each positioned on a respective one of the frangible ribs 124. In the illustrated embodiment, the prestressing projections 131 are provided on alternate ones of the frangible ribs 124, but a fewer or greater number of the projections 131 can be similarly provided.

5

Projections 131 can be provided to prestress the frangible ribs 124 attendant to both application and removal of the closure. During application of the closure to the associated container, the projections 131 are engageable with the container locking ring L, thus acting to expand and "bell out" the pilfer band 20 attendant to application. This action can act to weaken the unscored, residual portion of each frangible rib 124, thereby facilitating failure of the frangible ribs in the intended manner during closure removal.

10
15

Additionally, the prestressing projections 131 can cooperate with the locking ring L during closure removal. In particular, this can occur in conjunction with stressing and fracture of the ribs 124 when tabs 28 extend angularly downwardly, and are positioned between the container locking ring L and interference bead 30. Attendant to this action, the projections 131 provide additional interference with the container locking ring, thus desirably subjecting the frangible ribs 124 to additional stress to assure fracture and failure of the ribs.

20
25

A further feature of the embodiment of FIGURE 8 concerns configuring the pilfer band 20 for fracture of the band portion 22, which is ordinarily desired, as discussed above, in conjunction with the provision of an unscored connector portion which integrally joins the pilfer band to the skirt portion 16 after fracture of ribs 124. By such an arrangement, the pilfer band

30

remains joined to, but partially detached from, the skirt portion 16.

To this end, FIGURE 8 illustrates the manner in which a vertical score is preferably formed in the pilfer band 20. Specifically, an external scoring knife is preferably applied to the pilfer band so as to form one or more scores extending to a depth as illustrated in phantom line at 133. Preferably, such vertical scoring is provided between one of the flexible tabs 28 and an adjacent frangible rib 124, so that such vertical scoring does not extend into either the tab 28 or the rib 124.

Notably, it is preferred that the vertical scoring extend partially, but not completely, into the interference bead 30, to thereby define a fracturable residual portion 135 of the pilfer band. This arrangement preserves a desired degree of strength in the pilfer band, to facilitate high-speed application, while still rendering the pilfer band fracturable in the intended manner.

Thus, a high degree of tamper-resistance is provided by the present closure. As will be appreciated, various modifications and departures from the illustrated embodiment can be effected. For example, the number, spacing, thickness, and configuration of the flexible tabs 28 can be varied and selected while keeping with the principles disclosed herein. Similarly, while the annular interference bead 30 is preferably substantially continuous in nature for providing additional circumferential hoop strength for the closure, segmented or otherwise discontinuous configurations for the interference bead can be alternately employed. Moreover, while the present invention has been illustrated in the form of a one-piece, all plastic closure, it will be appreciated that

5

20
28
124

133
135

30

25

28

30

35

a closure embodying the present invention may be composite in nature, such as a combination metallic and plastic closure (with or without a separate sealing liner).

5 Referring now to FIGURES 9-11, therein is illustrated a further embodiment of tamper-indicating plastic closure 10. In accordance with previous embodiments, this plastic closure 10 includes a cup-like closure cap 12 having a circular top wall portion 14, and a depending annular or cylindrical skirt portion 16 having an internal thread formation 18. As shown in FIGURE 9, closure 10 is intended to be applied to an associated container C having an external bead-like locking ring L which extends circumferentially of the neck portion of the container perpendicular to the vertical axis thereof. Locking ring L is positioned just beneath external container threads T, with the container C including a hand grip or handle H.

10
15
20
25
In this embodiment, the closure includes an annular pilfer band 20 depending from skirt portion 16 which is at least partially detachably connected to the skirt portion by a plurality of circumferentially spaced apart fracturable bridges 22. The fracturable bridges can alternately be provided generally along the inner surfaces of the pilfer band and skirt portion, such as disclosed in U.S. Patent No. 4,418,828.

30
35
Pilfer band 20 includes an annular, bead-like interference lip 24 extending circumferentially about the inner surface of the pilfer band 20. Notably, interference lip 24 does not extend perpendicularly to the vertical axis of closure 10, but rather extends in a plane arranged at an acute angle relative to the vertical axis of the closure. In the preferred form, this plane is arranged at an acute angle in the range of about 1 degree to about 5 degrees relative to the

closure axis. While the interference lip as shown is extending continuously about the inner surface of the pilfer band 20, it should be recognized that the lip 24 may be otherwise configured, so as to extend discontinu-
5
discontinually about the inner surface such as by the provision of a series of segments, lugs, or like projections. Whether the interference lip 24 is of a continuous or discontinuous configuration, it is contemplated that the lip extends in a skewed or non-perpendicular relationship to the vertical axis of the closure.

By virtue of the skewed configuration of the interference lip 24 with respect to the closure axis, non-circular engagement is created between the interference lip and the locking ring L of the container during application and removal of the closure. Consequently, stresses created on the closure, are non-uniform about the circumference of the closure.

During application, this non-uniform stressing desirably results in the deformation of the pilfer band 20 to an out-of-round, non-circular configuration, i.e., to a generally elliptical or oval shape. This deformation in the pilfer band facilitates movement of the interference lip past the locking ring L during application of the closure to the container, thereby reducing the force required for application and minimizing stresses created on fractureable bridges 22. During closure removal, the interference lip 24 again cooperated with the container locking ring L to create a non-uniform stressing of the pilfer band 20, and in particular provide a progressive stressing of fractureable bridges 22. During closure removal, that portion of the interference lip 24 closest to the top wall portion 12 of the closure first engages the locking ring L of the container. This results in localized
10
15
20
25
30
35

stressing in the region of this initial engagement. In this manner, progressive failure of the bridges 22 can be induced.

5 In order to prevent the interference lip 24 from slipping over the locking ring L without failure of bridges 22 during closure removal, it is desirable to provide means for preventing the pilfer band 22 from assuming a non-circular configuration. To this end, a plurality of circumferentially spaced centering ribs 26 are provided on the inside surface of pilfer band 20 above interference lip 24. Centering ribs 26 are positioned to engage the container locking ring L during closure removal, and thus maintain the pilfer band in a circular configuration.

10
15
20
25
As will be appreciated, other suitable forms of centering means can be employed, such as by the provision of a continuous ring on the interior of the closure, or by the provision of an area of relatively reduced inside diameter just above the interference lip. In essence, it is contemplated that a centering arrangement be provided for engagement with locking ring L as the interference lip 24 engages the locking ring, to thereby prevent the pilfer band from assuming a non-circular configuration, thus assuring the intended fracture of bridges 22.

30 From the foregoing, it will be observed that numerous modifications and variations can be effected without departing from the true spirit and scope of the novel concept of the present invention. It is to be understood that no limitation with respect to the specific embodiments is intended or should be inferred. The disclosure is intended to cover by the appended claims all such modifications as fall within the scope of the claims.

The claims defining the invention are as follows:

1. A tamper-indicating plastic closure for a container having an annular locking ring, said closure comprising:

5 a plastic cap having a top wall portion, and an annular, depending cylindrical skirt portion; and

an annular pilfer band depending from said skirt portion and at least partially detachably connected thereto by frangible rib means,

10 said pilfer band including an annular band portion, a plurality of circumferentially spaced, inwardly extending flexible tab means, and an annular interference bead positioned beneath said flexible tab means and extending inwardly of the bottom edge of said annular band portion;

15 said flexible tab means being engageable with said container locking ring: (1) when said flexible tab means extend generally angularly upwardly and inwardly of said annular band portion for fracturing said frangible rib means, and (2) when said flexible tab means extend generally angularly downwardly and inwardly of said annular band and are disposed between said annular locking ring and said interference bead for fracturing said frangible rib means.

20 2. A tamper-indicating plastic closure in accordance with claim 1, wherein

25 said frangible rib means comprises a plurality of frangible ribs extending between the inside surfaces of said skirt portion and said annular band portion of said pilfer band, said pilfer band being distinguished and at least partially separated from said skirt portion by circumferential score means extending partially into said frangible ribs.

3. A tamper-indicating plastic closure in accordance with claim 2, wherein

each of said flexible tab means has a thickness about equal to the radial dimension of said frangible ribs.

30 4. A tamper-indicating plastic closure in accordance with claim 1, wherein

each of said flexible tab means has a thickness dimension between about 0.012 inches and 0.020 inches.

35 5. A tamper-indicating plastic closure in accordance with claim 1, including

centering means engageable with said container locking ring for centering said closure on said container.



6. A tamper-indicating plastic closure in accordance with claim 5, wherein

5 said frangible rib means comprises a plurality of circumferentially spaced frangible ribs extending between the inside surfaces of said skirt portion and said annular band portion of said pilfer band, said centering means comprising portions of at least some of said frangible ribs extending between adjacent ones of said flexible tab means.

7. A tamper-indicating plastic closure in accordance with claim 2, including

10 scoring bead means extending circumferentially about the inside of said closure for supporting the interior of said closure during formation of said circumferential score means.

8. A tamper-indicating plastic closure in accordance with claim 2, including

15 prestressing means for prestressing said frangible ribs comprising a plurality of circumferentially spaced prestressing projections on the inside of said pilfer band each positioned on a respective one of said frangible ribs, said prestressing projections being engageable with said container locking ring for prestressing said frangible ribs.

20 9. A tamper-indicating plastic closure in accordance with claim 1, wherein

said pilfer band includes at least one vertical score means extending partially into said interference bead to define a fracturable residual portion of said pilfer band.

25 10. A tamper-indicating plastic closure for a container having an annular locking ring, said closure comprising:

a closure cap including a circular top wall portion and a depending, generally cylindrical skirt portion having an internal thread formation;

30 an annular pilfer band depending from said cylindrical skirt portion;

frangible rib means at least partially detachably connecting said pilfer band to said skirt portion, said frangible rib means comprising a plurality of spaced apart frangible ribs;

35 said pilfer band including interference means on the inside surface of said pilfer band, said interference means being engageable with the

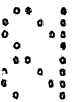
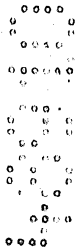

locking ring of said container during removal of said closure therefrom for fracturing said frangible ribs, said pilfer band further including centering means engageable with the locking ring of said container during removal of said closure therefrom for maintaining said pilfer band in a circular configuration.

5

11. A tamper-indicating plastic closure in accordance with claim 10, wherein

said frangible ribs extend between the inside surfaces of said skirt portion and said pilfer band, said centering means comprising portions of said frangible ribs extending on the inside surface of said pilfer band.

10

12. A tamper-indicating plastic closure in accordance with claim 10, wherein

interference means comprises an interference lip extending about the inner surface of said pilfer band beneath said centering means in a plane extending at an acute angle to the vertical axis of said closure.

15

13. A tamper-evident plastic closure substantially as hereinbefore described with reference to the accompanying drawings.

DATED this TWENTY-SECOND day of MAY 1992

H-C Industries, Inc.

Patent Attorneys for the Applicant
SPRUSON & FERGUSON



48910/90

FIG. 1

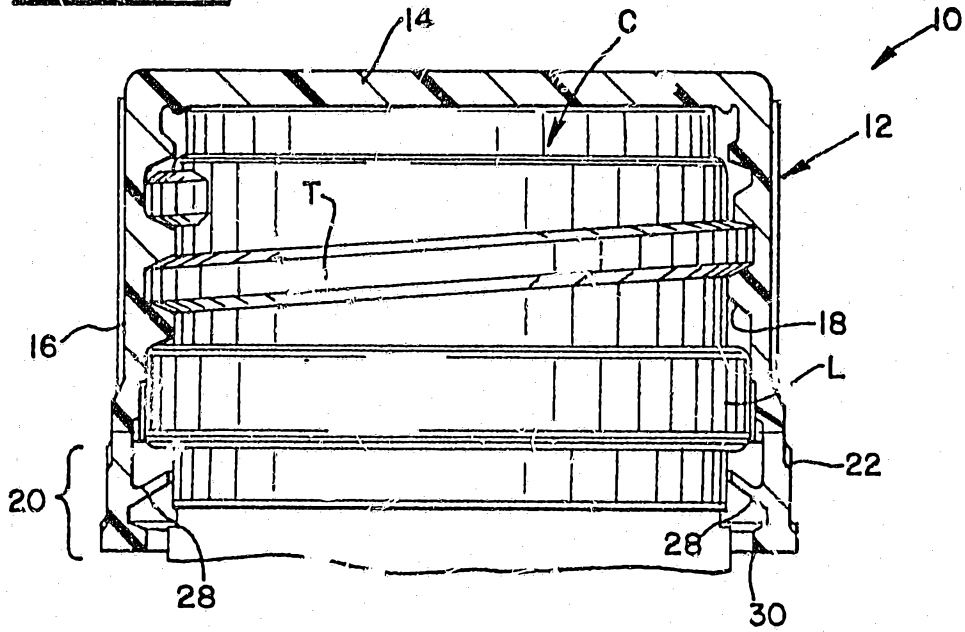

FIG. 2

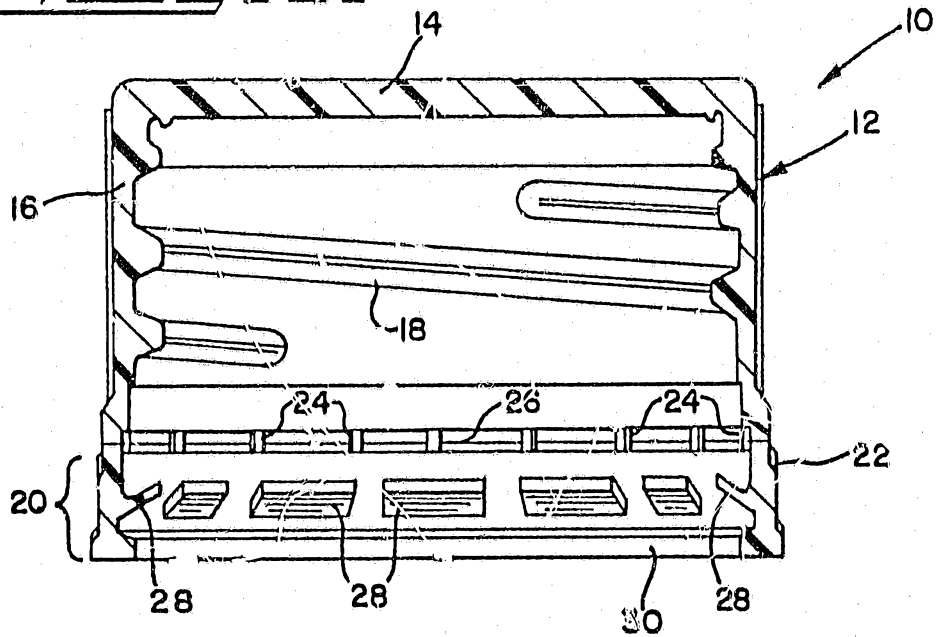

FIG. 3

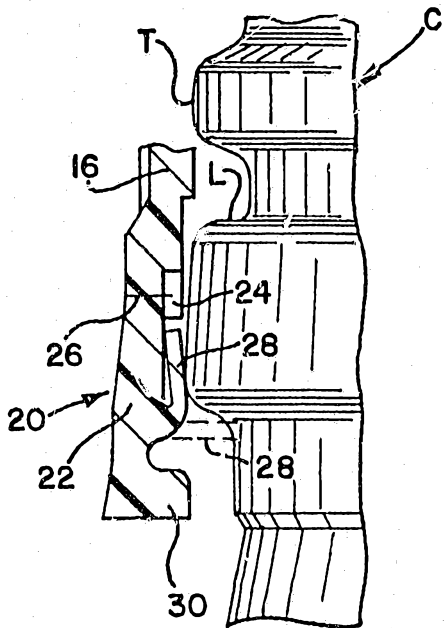

FIG. 4

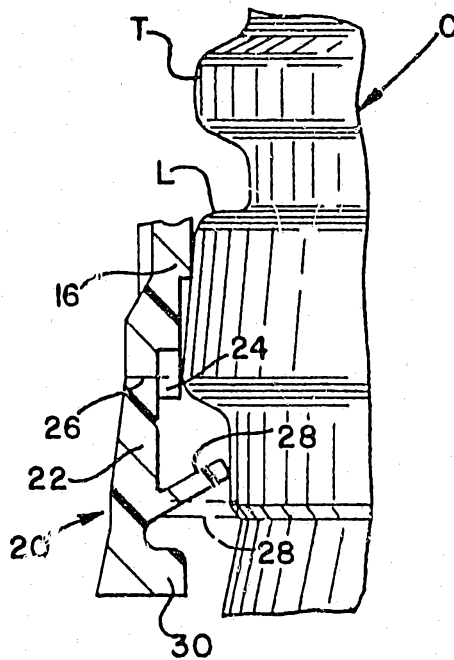

FIG. 5

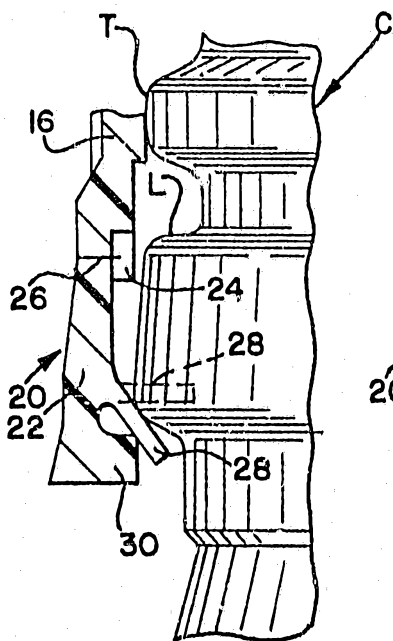

FIG. 6a - FIG. 6b

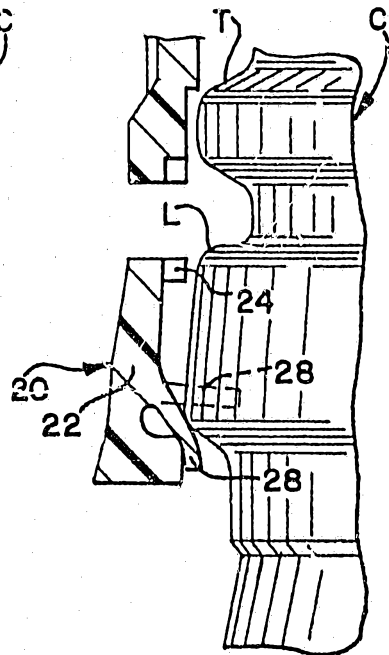
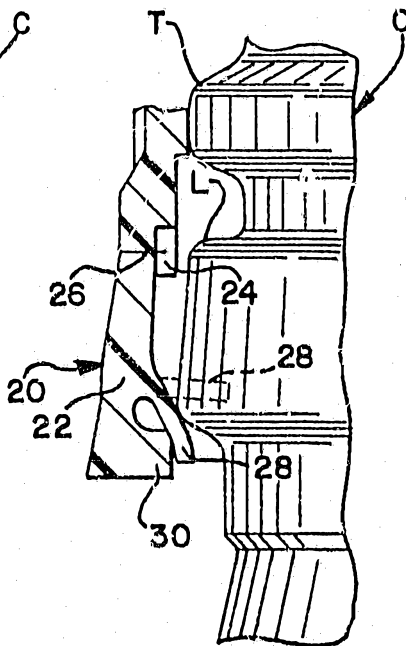

FIG. 7.

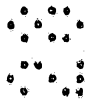
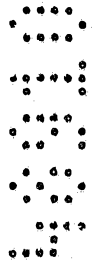
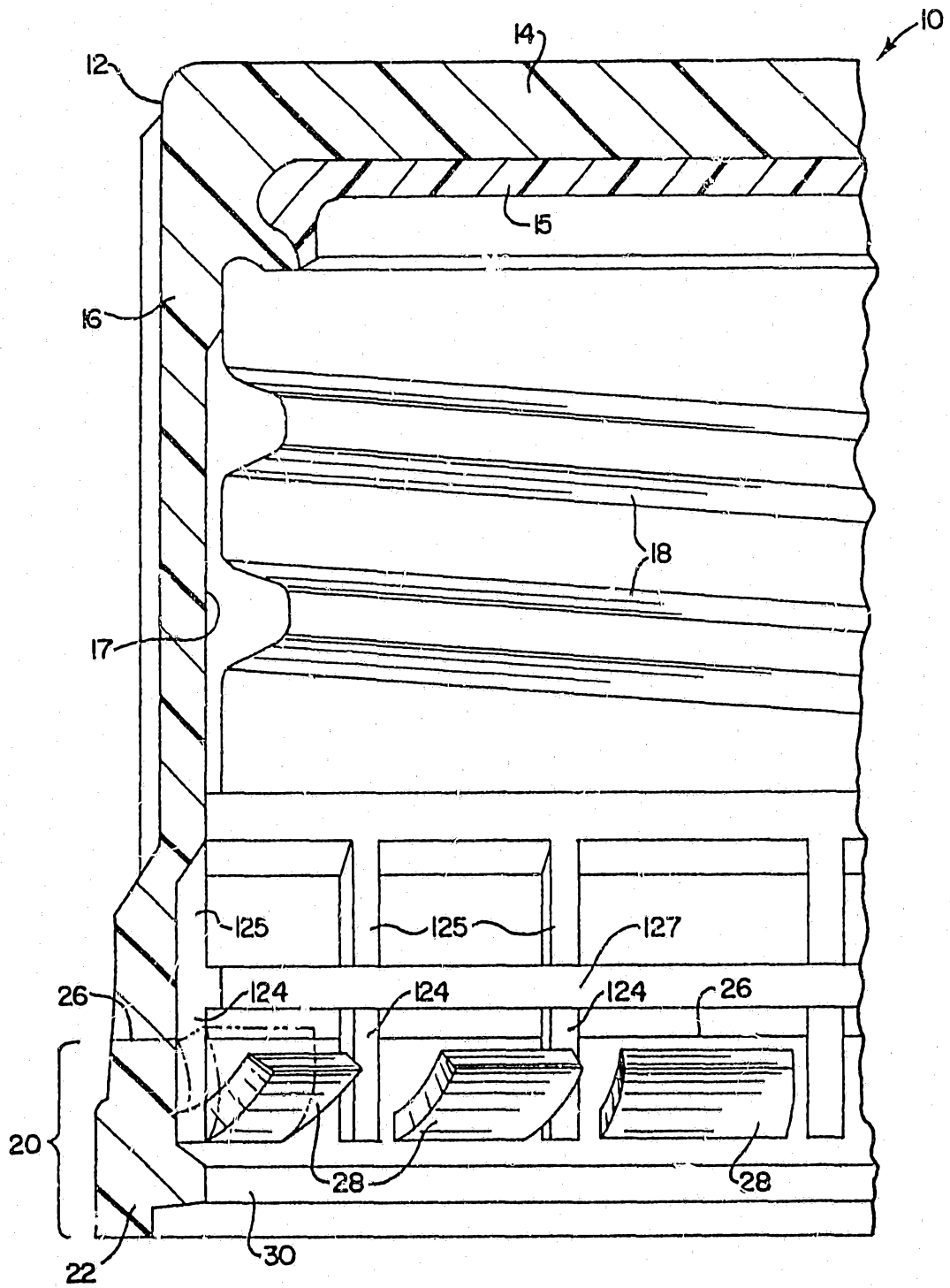

FIG-8-

