

(21) Application No **0111079.0**
(22) Date of Filing **04.05.2001**
(30) Priority Data
(31) **09567307** (32) **08.05.2000** (33) **US**

(71) Applicant(s)
American Airlines Inc
(Incorporated in USA - Texas)
PO Box 619616 MD 5675, Dallas/Ft Worth Airport,
TX 75261-9616, United States of America

(72) Inventor(s)
Ian H Dryburgh
Benedict N Samuels
Simon Lunn
Carl R Lehew
James R Hadden Jr
John R Higgins

(51) INT CL⁷
B60N 2/34 // B64D 11/06

(52) UK CL (Edition S)
A4L LABB LBBA L109 L112 L113 L149
B7W WFE

(56) Documents Cited
GB 2295962 A **WO 00/21831 A1** **JP 110152094 A**
US 5954401 A

(58) Field of Search
UK CL (Edition S) **A4L LABB LBBA LBLA LBMB , B7W**
WFE
INT CL⁷ **B60N 2/005 2/01 2/34 , B61D 33/00 , B64D**
11/06
Online: **EPODOC, WPI & PAJ.**

(74) Agent and/or Address for Service
Noel J Akers
Howrey Simon Arnold & White, City Point,
One Ropemaker Street, LONDON, EC2Y 9HS,
United Kingdom

(54) Abstract Title
A method and system for seating passengers in a transportation system

(57) An airplane, system and passenger cabin comprising columns and rows (fig 1B) of recliners 220a-e in the form of compartments 106c-d is disclosed. Each recliner 220a-e comprises a rotatable and releasably lockable chair 232a-e with a detached ottoman/footrest 234a-e (which may also be used as a seat), towards which the chair faces after rotation from a first angular position (generally facing the front of the plane), through an angle of greater than 10 degrees, to a second angular position (facing a second stowable table 228). Chair rotation to a third angular position (perpendicular to the first) allows the chair to face a first table 226a-e, window 236 or removable divider/partition (fig 1B, 122 and 146, from which a recliner support may also be formed). When fully reclined (fig 3B), the armrests (314) and upper surface of the seat (312) are generally flush. Chair 232a-e (and fig 3A) also comprises an indicator (323 and fig 3D) which indicates when the chair is locked in to the first angular or any other desired position.

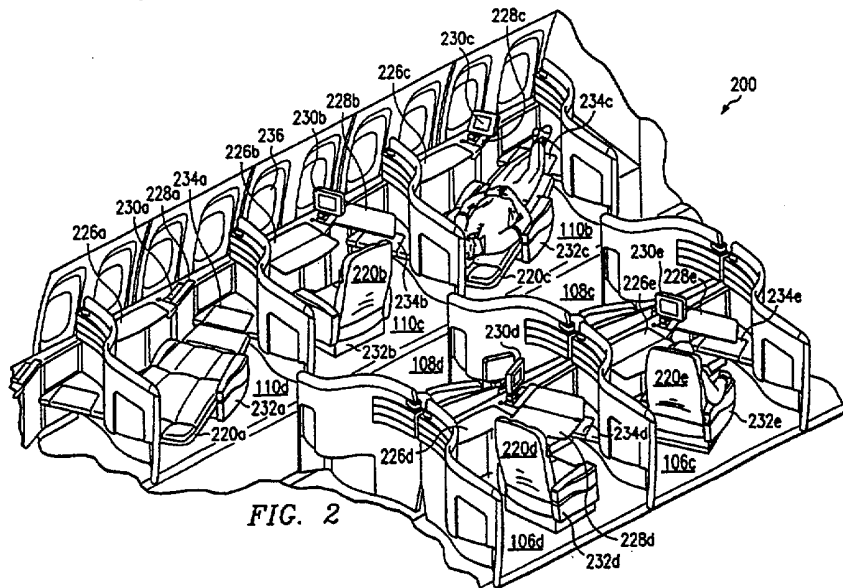

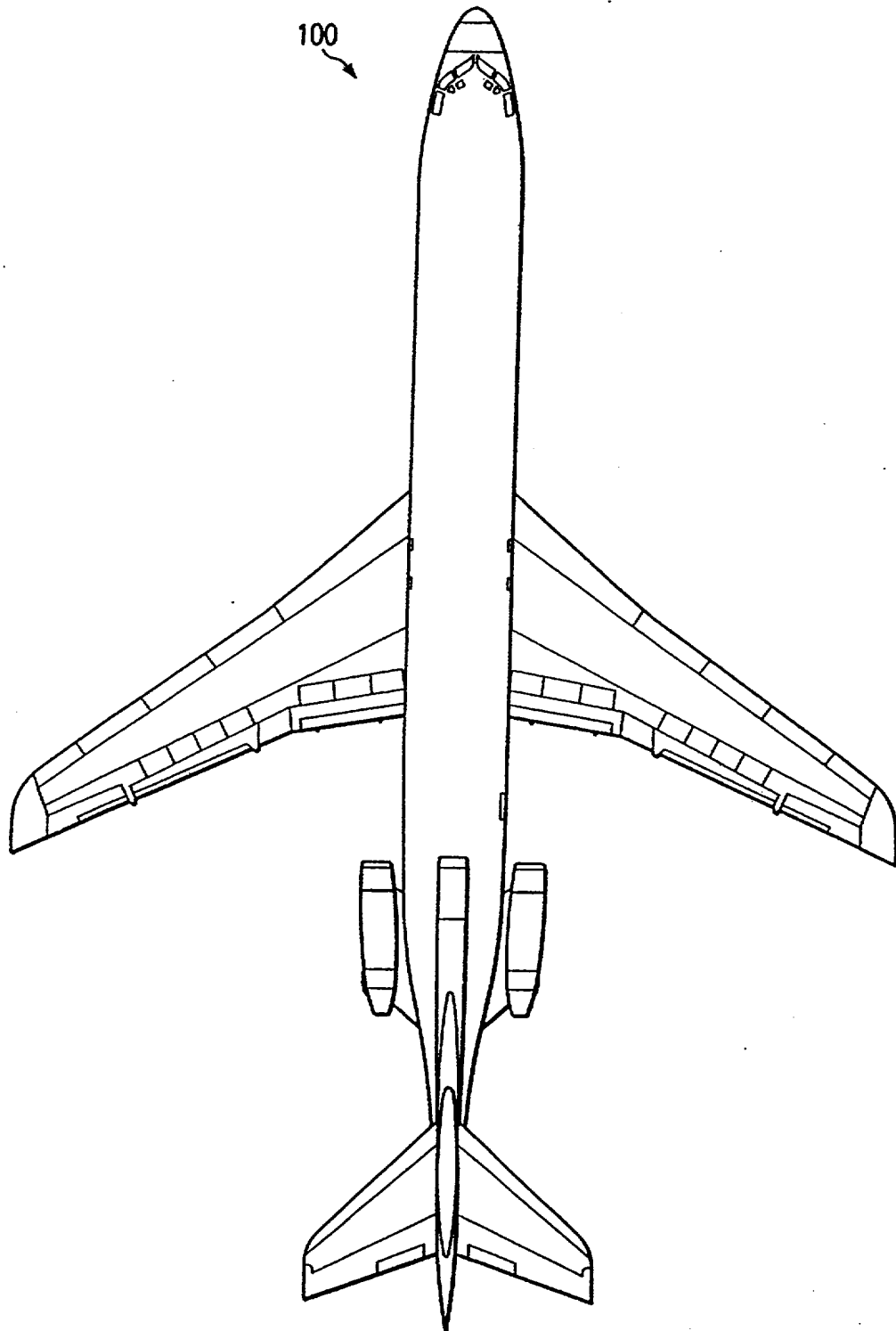
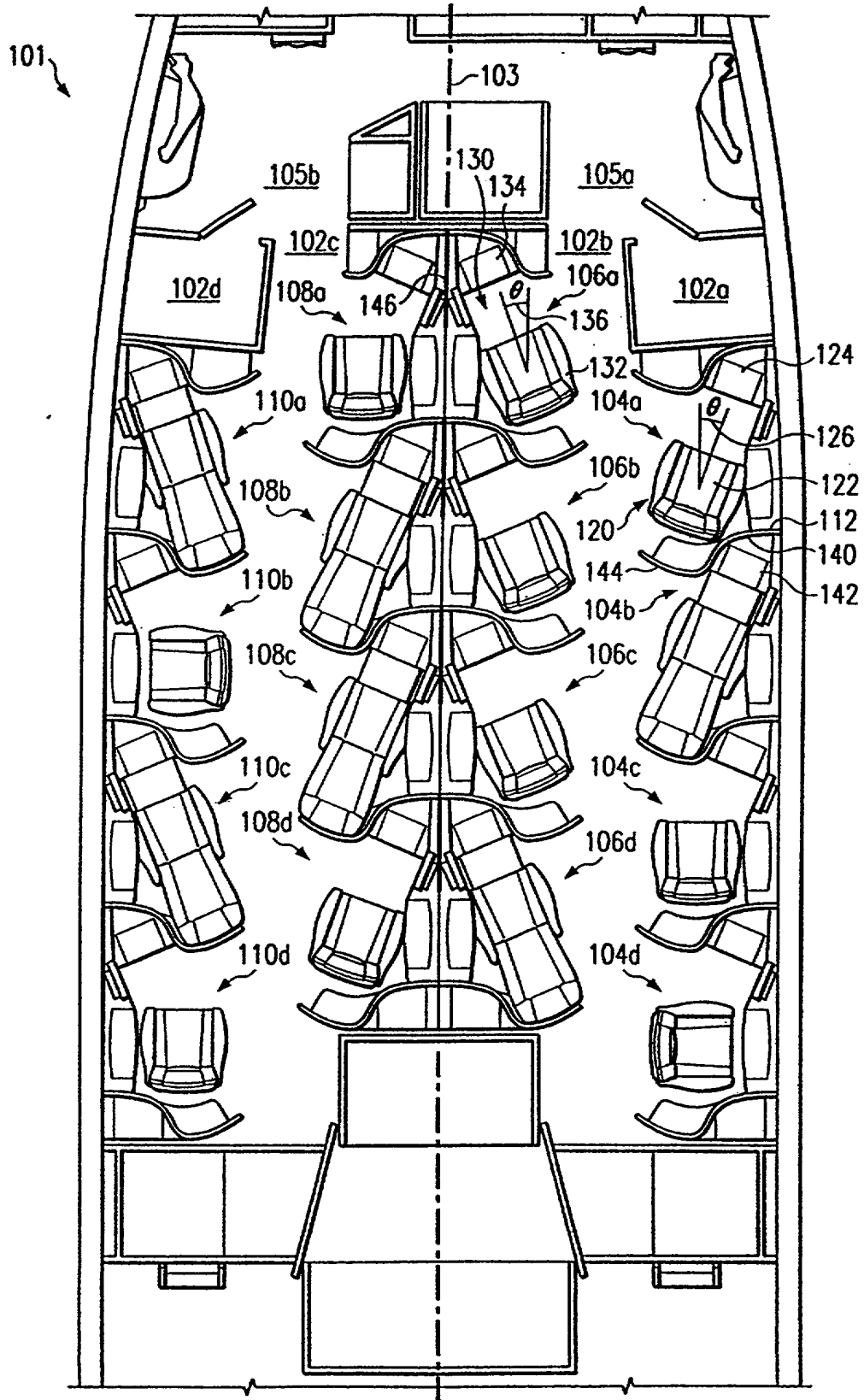

FIG. 1A

FIG. 1B



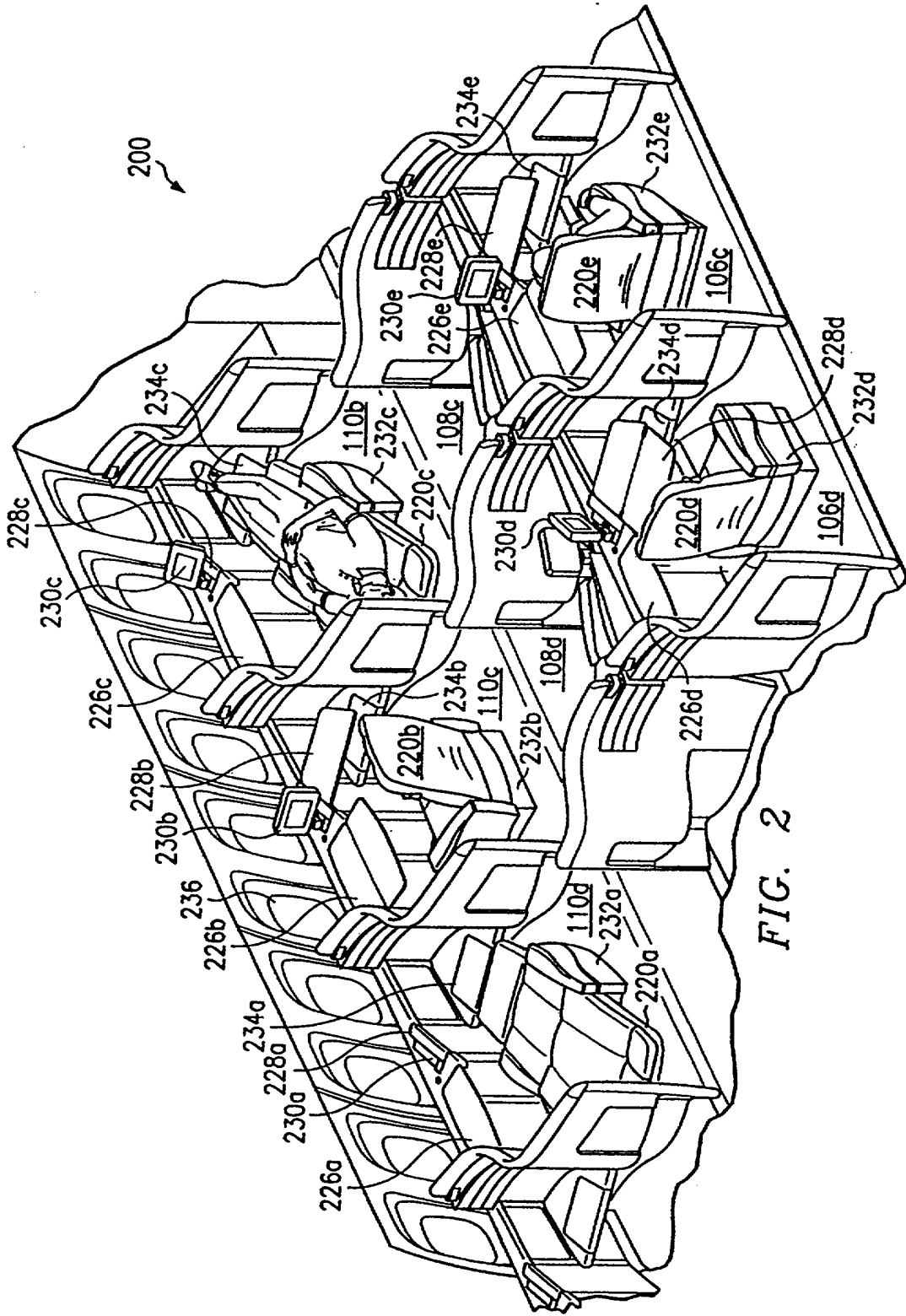

FIG. 2

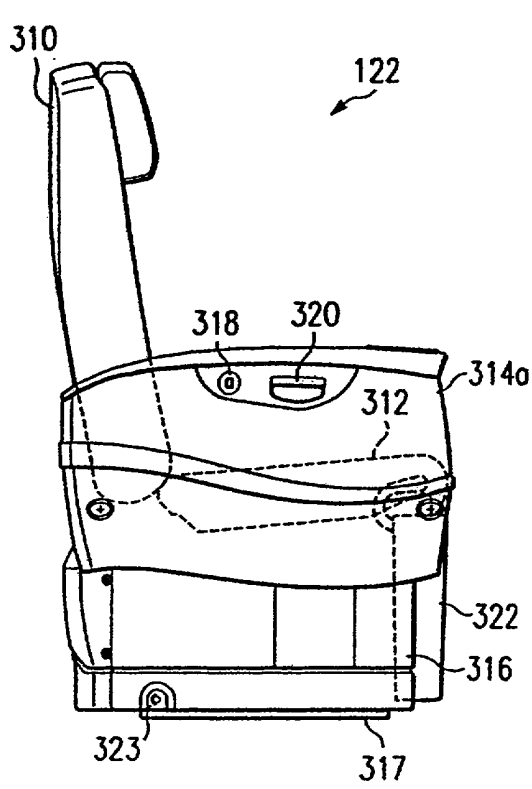

FIG. 3A

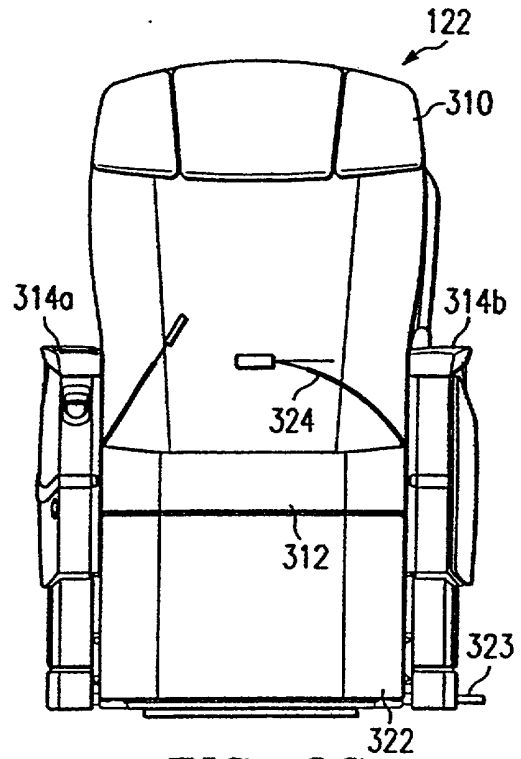

FIG. 3C

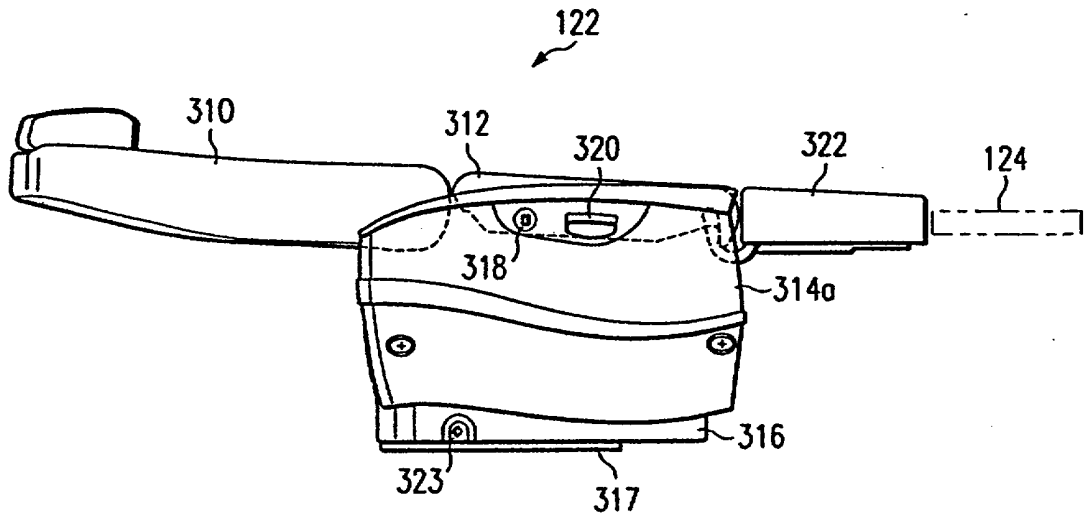

FIG. 3B

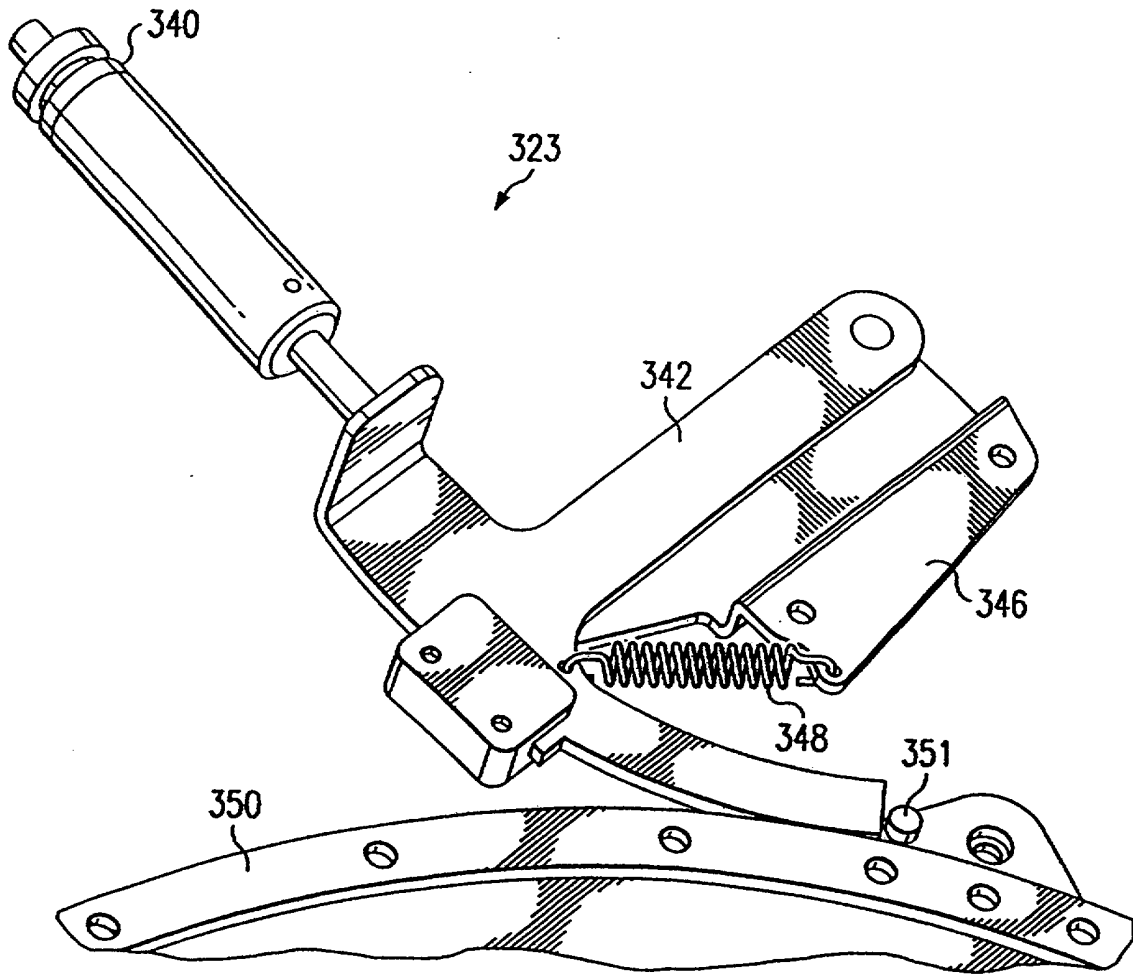
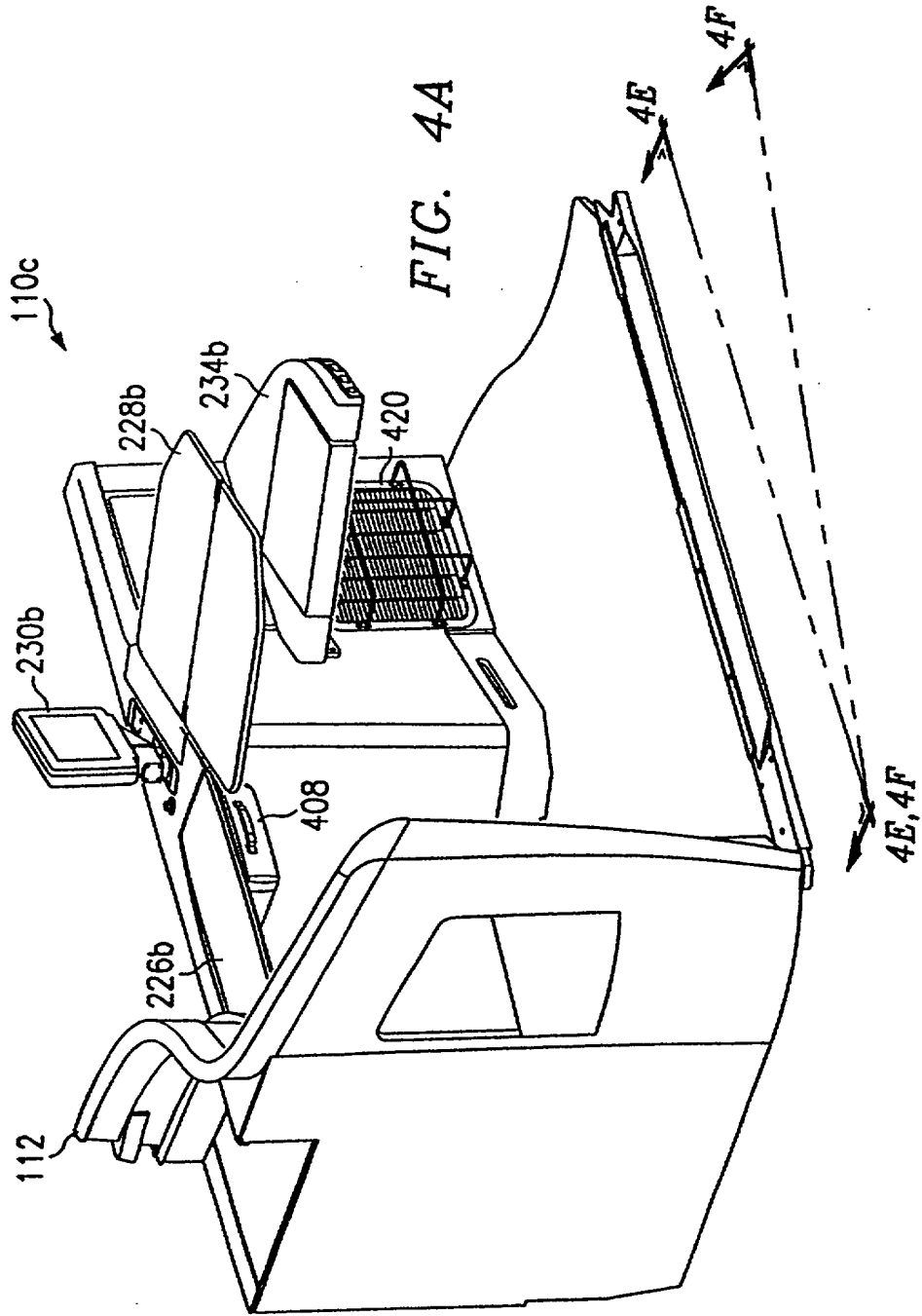
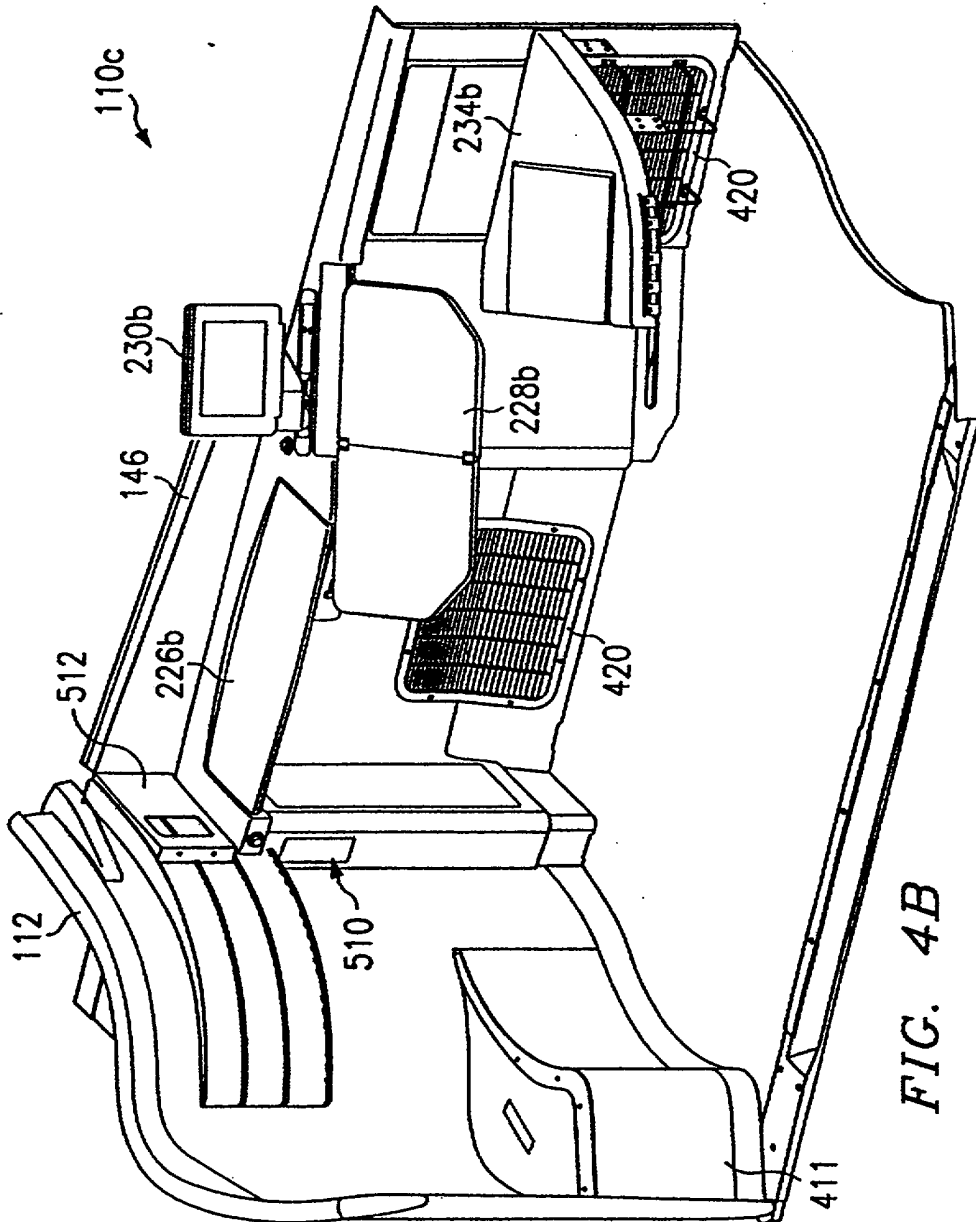

FIG. 3D





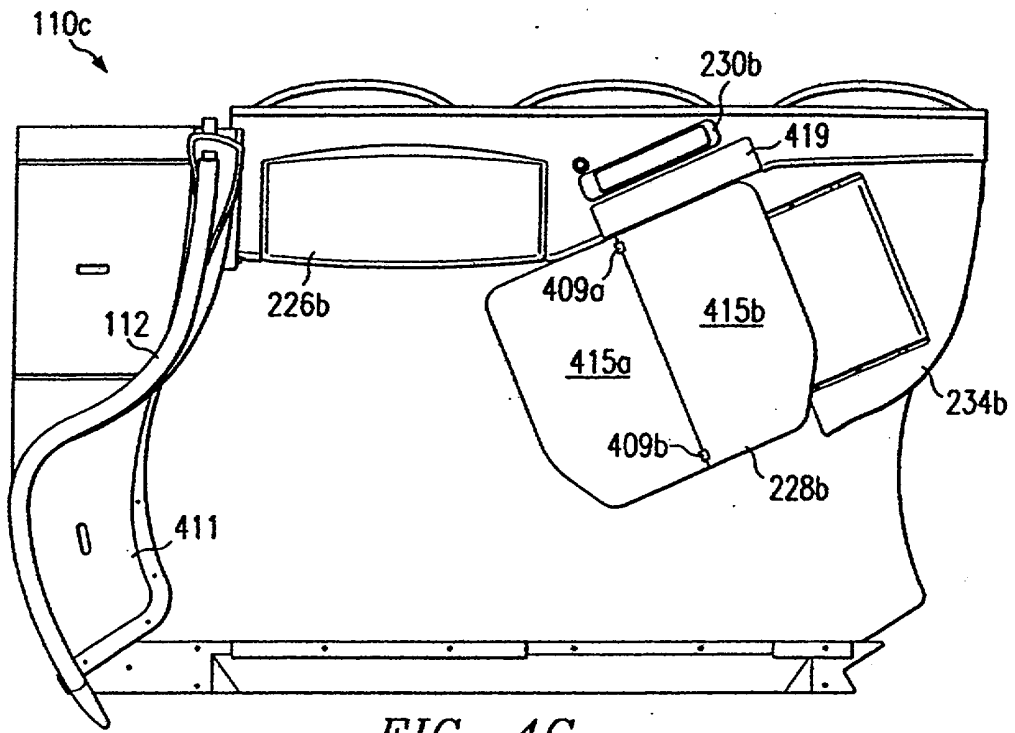

FIG. 4C

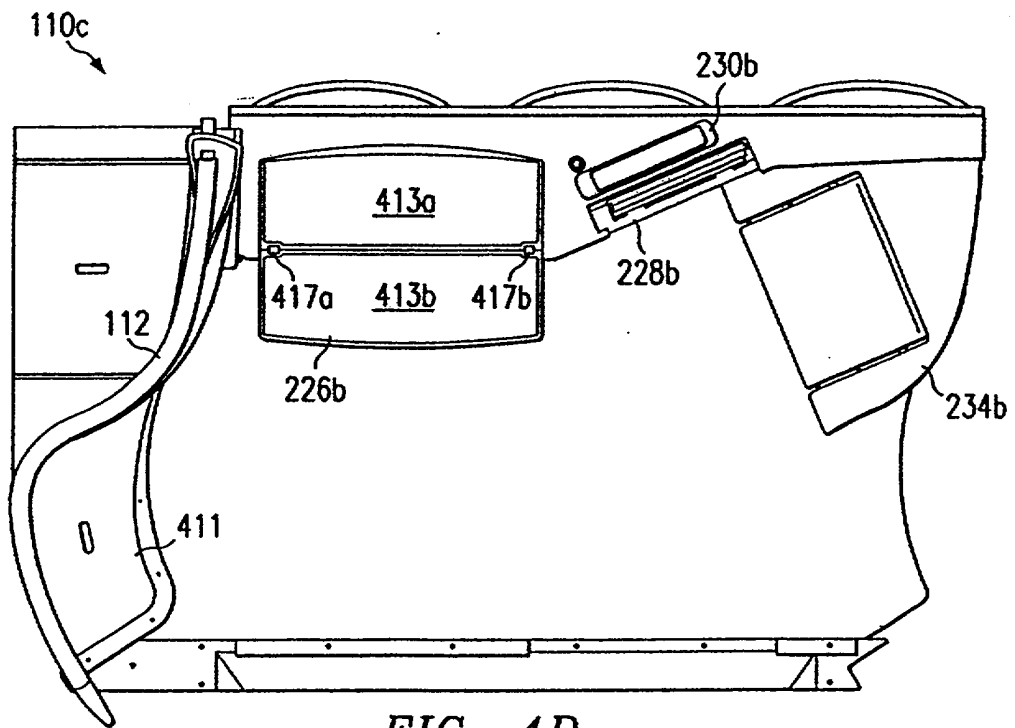

FIG. 4D

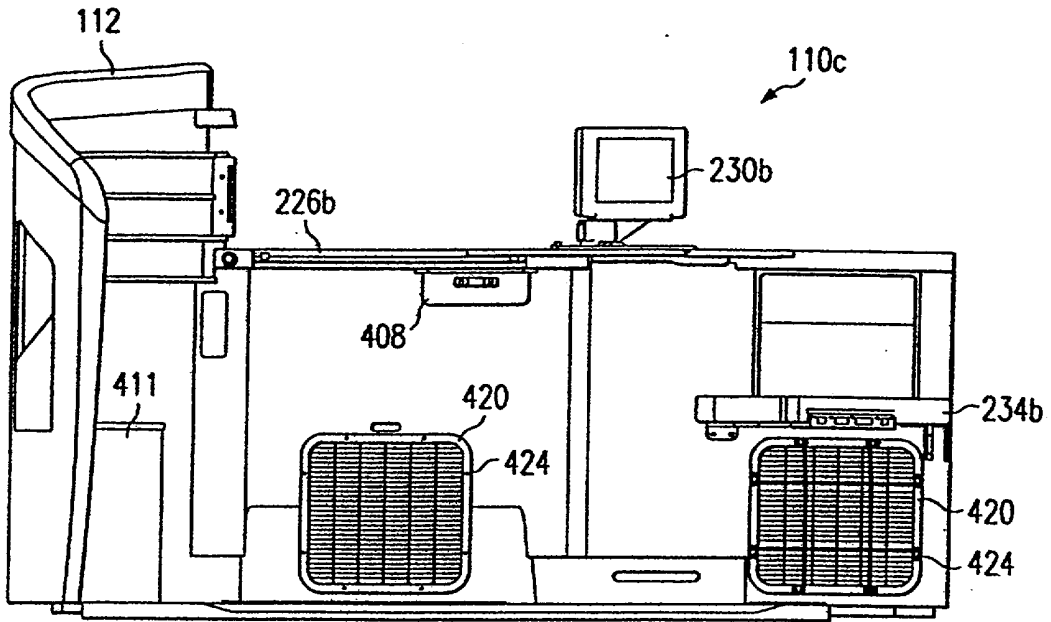

FIG. 4E

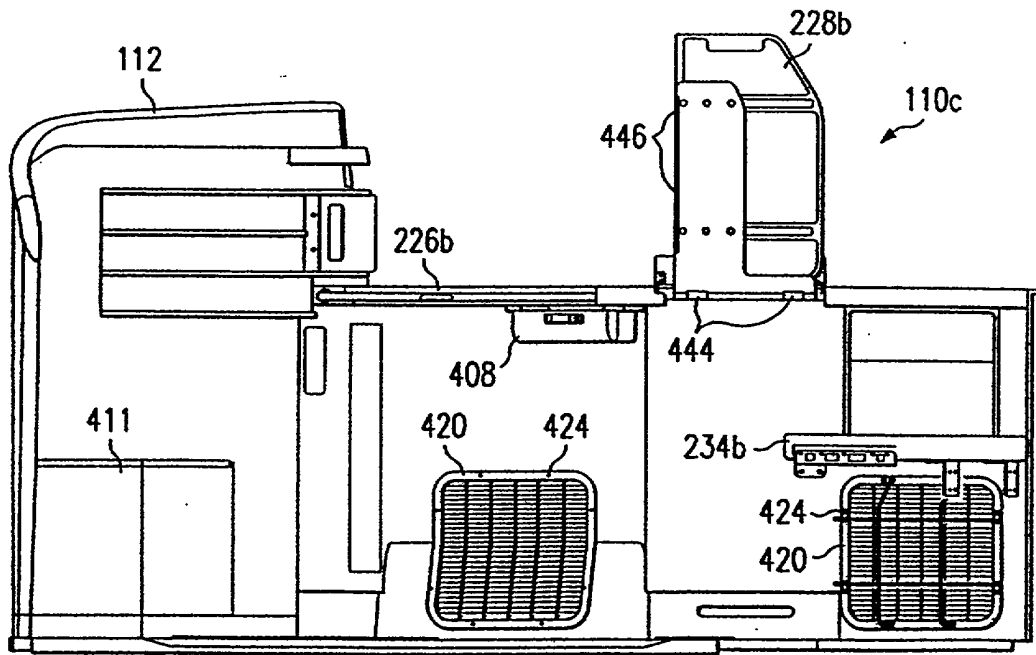

FIG. 4F

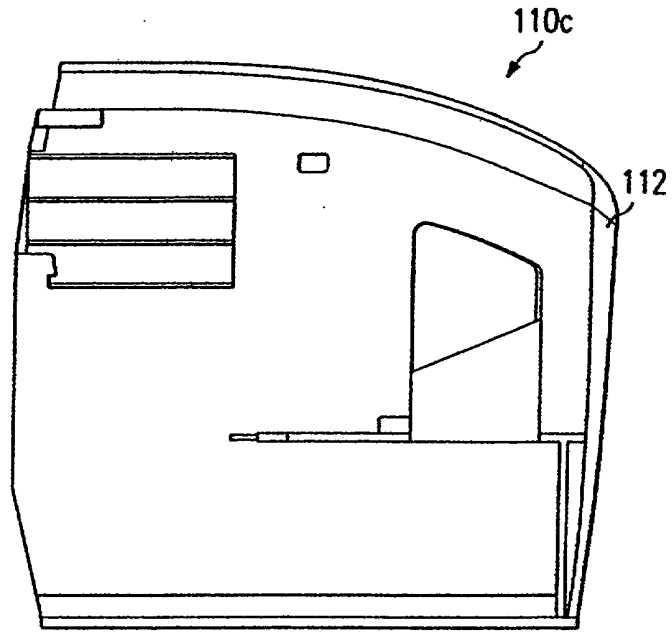

FIG. 4G

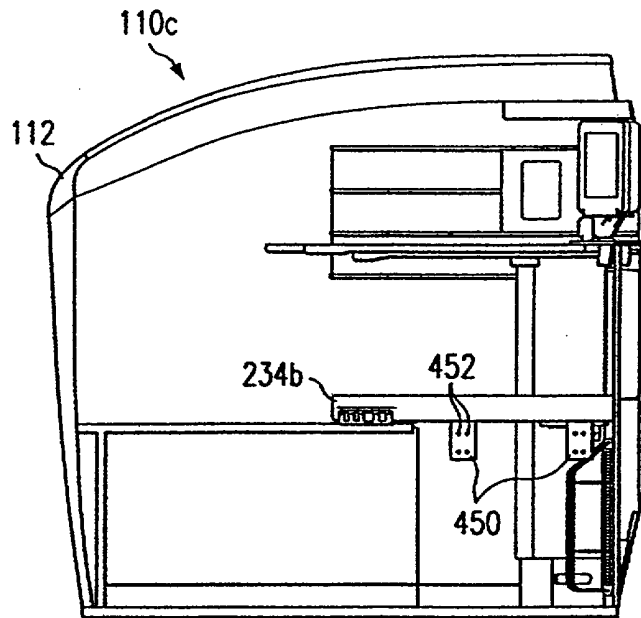

FIG. 4H

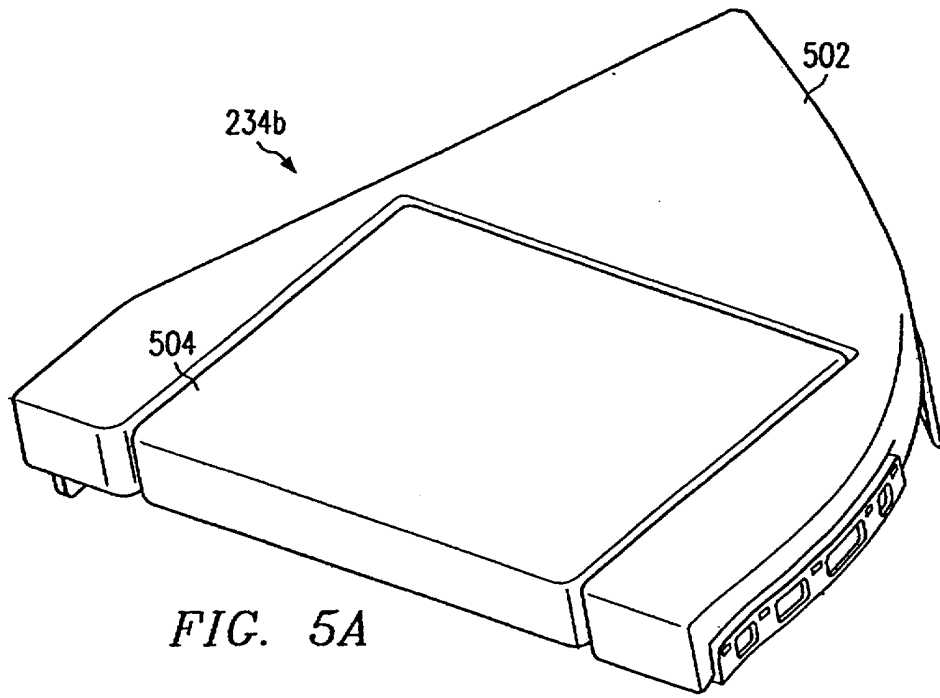

FIG. 5A

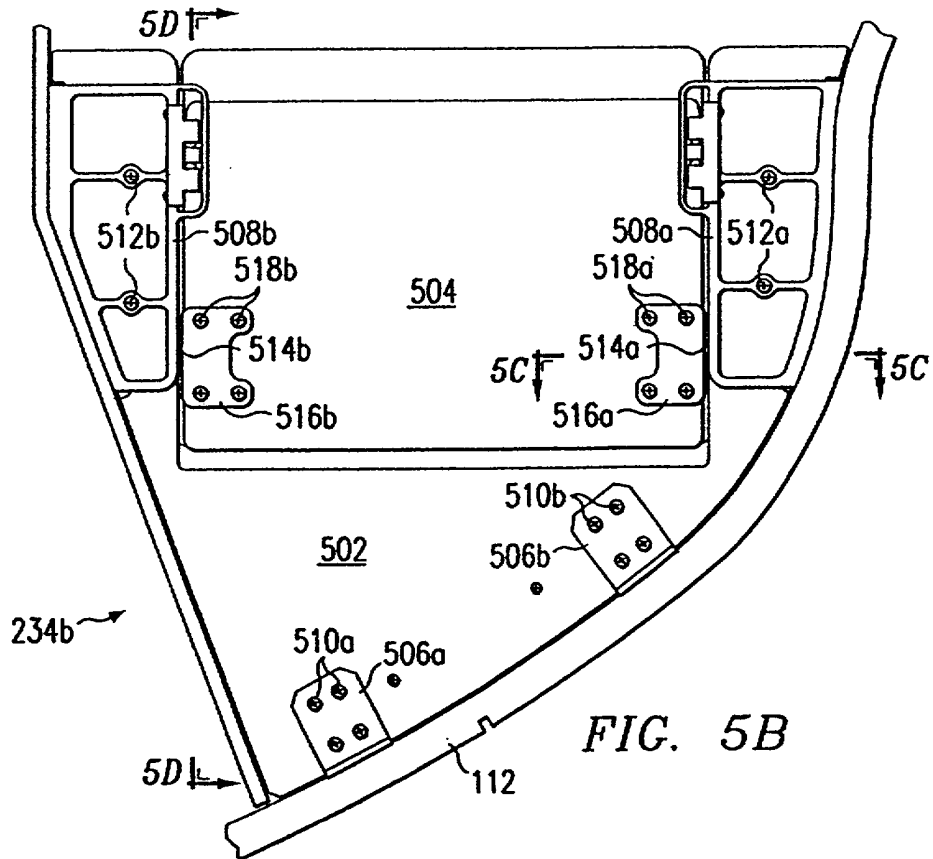

FIG. 5B

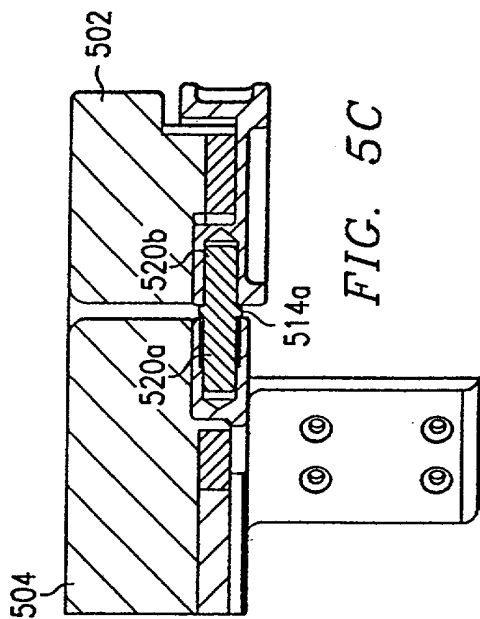

FIG. 5C

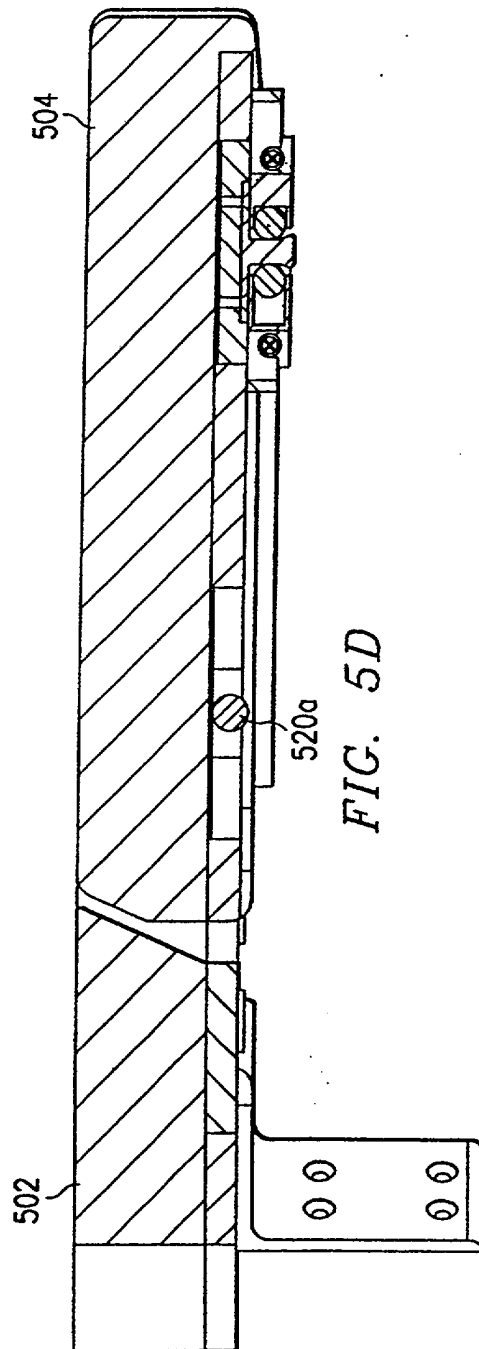

FIG. 5D

METHOD AND SYSTEM FOR SEATING PASSENGERS IN A
TRANSPORTATION SYSTEM

TECHNICAL FIELD OF THE INVENTION

This invention relates generally to the field of transportation systems and more specifically to a method and system for seating passengers in a transportation system.

BACKGROUND OF THE INVENTION

Increased airline travel has led to a demand for improved methods and systems for seating passengers. Airlines are faced with the problem of accommodating more passengers efficiently, yet comfortably. Placing more passengers on one flight increases the revenue of the flight, but decreases the amount of space per passenger, lowering passenger satisfaction. Additionally, passengers who travel in first class cabins, especially those traveling over long distances, have higher expectations of quality and comfort. Moreover, airlines must follow Federal Aviation Administration (FAA) regulations for seating passengers. Accordingly, seating many passengers comfortably, while satisfying FAA regulations, has posed a challenge for airlines.

SUMMARY OF THE INVENTION

While known approaches have provided improvements over prior approaches, the challenges in the field of transportation systems have continued to increase with demands for more and better techniques having greater effectiveness. Therefore, a need has arisen for a new method and system for seating passengers in a transportation system.

In accordance with the present invention, a method and system for seating passengers in a transportation system are provided that substantially eliminate or reduce the disadvantages and problems associated with previously developed systems and methods.

According to one embodiment of the present invention, an airplane is disclosed. The airplane comprises a column of recliners within the airplane. Each recliner has an ottoman and a chair detached from the ottoman. The chair is releasably lockable in a first angular position and rotatable to a second angular position generally facing the ottoman.

According to one embodiment of the present invention, a system for passenger seating is disclosed. The system comprises a first recliner having a first ottoman and a first chair detached from the first ottoman. The first chair is releasably lockable in a first angular position and rotatable to a second angular position generally facing the first ottoman. A first angle is defined between the first angular position and the second angular position. A second recliner detached from the first recliner comprises a second ottoman and a second chair detached from the second ottoman. The

second chair is releasably lockable in a third angular position and rotatable to a fourth angular position generally facing the second ottoman. A second angle is defined between the third angular position and the fourth angular position, where the first angle and the second angle are approximately equal in magnitude.

According to one embodiment of the present invention, an indicator for a passenger seat is disclosed. The indicator comprises a gauge coupled to a passenger seat. The gauge determines that the passenger seat is facing in a desired direction. A signal device coupled to the gauge indicates that the passenger seat is facing in the desired direction.

According to one embodiment of the present invention, a passenger cabin is disclosed. The passenger cabin comprises a first recliner comprising a first ottoman and a first chair and a second recliner comprising a second ottoman and a second chair. The second chair is spaced from the first chair in a first angular position and the second chair is spaced from the second ottoman in a second angular position. A partition separates the first recliner from the second recliner.

Embodiments of the present invention provide numerous technical advantages. For example, a technical advantage of one embodiment of the present invention is that a passenger cabin may provide many passenger compartments. Each passenger compartment may have a recliner that allows a passenger to swivel and fully recline. Two tables may be available in each passenger compartment. Two passengers may be comfortably seated at one of the tables in the passenger compartment. A

partition may be used to separate one passenger compartment from an adjoining passenger compartment, and may allow passengers in both compartments to comfortably recline. Another technical advantage of one embodiment of the present invention is that the passenger may face forward during take-off and landing, which facilitates compliance with some FAA regulations. An indicator may be used to indicate that the passenger is facing in the forward direction. Consequently, the present invention may result in more efficient and more comfortable seating of passengers in a transportation system.

Other technical advantages are readily apparent to one skilled in the art from the following figures, descriptions, and claims. For example, the invention has been described in the particular context of seating a passenger on a airplane. The teachings of the inventions are applicable to other types of travel as well.

BRIEF DESCRIPTION OF THE DRAWINGS

For a more complete understanding of the present invention and for further features and advantages, reference is now made to the following description, taken in conjunction with the accompanying drawings, in which:

FIGURE 1A illustrates one embodiment of an airplane that includes seating for passengers according to the teachings of the present invention;

FIGURE 1B is a top view of one embodiment of a passenger cabin of the airplane of FIGURE 1A showing seating for passengers according to the teachings of the present invention;

FIGURE 2 is a perspective view of one embodiment of passenger compartments according to the teachings of the present invention;

FIGURE 3A is a side view of one embodiment of a chair in an upright position according to the teachings of the present invention;

FIGURE 3B is a side view of the chair of FIGURE 3A in a reclined position;

FIGURE 3C is a front view of the chair of FIGURE 3A;

FIGURE 3D is a perspective view of an indicator of the chair of FIGURE 3A;

FIGURE 4A is a perspective view of one embodiment of a passenger compartment according to the teachings of the present invention;

FIGURE 4B is another perspective view of the passenger compartment of FIGURE 4A;

FIGURE 4C is a top view of the passenger compartment of FIGURE 4A;

FIGURE 4D is another top view of the passenger compartment of FIGURE 4A;

FIGURE 4E is a side view of the passenger compartment of FIGURE 4A along line 4E-4E of FIGURE 4A;

FIGURE 4F is another side view of the passenger compartment of FIGURE 4A along line 4F-4F of FIGURE 4A;

FIGURE 4G is a left end view of the passenger component of FIGURE 4A;

FIGURE 4H is a right end view of the passenger component of FIGURE 4A;

FIGURE 5A is a perspective view of one embodiment of a foot rest of FIGURE 4A according to the present invention;

FIGURE 5B is an underside view of the ottoman of FIGURE 5A;

FIGURE 5C is a cross-section view of the ottoman of FIGURE 5B along line 5C-5C; and

FIGURE 5D is another cross-section view of the ottoman of FIGURE 5B along line 5D-5D.

DETAILED DESCRIPTION OF THE DRAWINGS

Embodiments of the present invention and its advantages are best understood by referring to FIGURES 1 through 5 of the drawings, like numerals being used for like and corresponding parts of the various drawings.

FIGURE 1A illustrates an airplane 100 that may include seating for passengers according to the teachings of the present invention. Airplane 100 may be, for example, a commercial airplane. Seating for passengers is described in more detail in conjunction with FIGURES 1B through 5D.

FIGURE 1B is a top view of a passenger cabin 101 of airplane 100 of FIGURE 1A, showing seating for passengers according to the teachings of the present invention. Passenger cabin 101 has a centerline 103 that is coincident with a line that runs generally from the tip to the tail of airplane 100. Passenger cabin 101 comprises four columns 102a-d that are generally parallel to centerline 103, and each column 102a-d comprises four passenger compartments 104a-d through 110a-d, respectively. Passenger cabin 101 may comprise more or fewer columns, and each column may comprise more or fewer passenger compartments. Column 102d may be a port column, column 102a may be a starboard column, and columns 102b-c may be center columns. Columns 102a-b are on an aisle 105a, and columns 102c-d are on an aisle 105b.

Passenger compartment 104a comprises a passenger seat, for example, a recliner 120 which is described in more detail in conjunction with FIGURES 2 and 3A-C. Recliner 120 comprises a chair 122 and an ottoman 124

coupled to a floor and/or wall of passenger compartment 104a. Chair 122 may be releasably lockable facing towards the front of airplane 100 in a direction generally parallel to centerline 103, and may rotate through an angle 126 to face ottoman 124. Recliners of passenger compartments 104b-d through 110a-d may be constructed in a similar manner. Passenger compartment 106a of column 102b comprises a recliner 130. Recliner 130 comprises a chair 132 and an ottoman 134. Chair 132 may face forward in a direction generally parallel to centerline 103, and may rotate through an angle 136 to face ottoman 134. Angle 136 may be approximately equal in magnitude and opposite in direction to angle 126. Passenger compartment 106a may share the same aisle 105a as passenger compartment 104a, or may be in a different aisle of passenger cabin 101.

Partitions 112 coupled to the floor of passenger cabin 101 may be used to separate passenger compartments in the same column to provide privacy. For example, partition 112 may be used to separate passenger compartment 104a from passenger compartment 104b. Partition 112 may be shaped to accommodate the passengers in passenger compartments 104a-b. For example, partition 112 may include a curve 140 to accommodate an ottoman 142 of passenger compartment 104b and another curve 144 to accommodate recliner 120 of passenger compartment 104a. Dividers 146 may be used to separate passenger compartments in the same row. For example, divider 146 may be used to separate passenger compartment 106a from passenger compartment 108a. Divider 146 may be a

removable divider, allowing passengers in passenger compartments 106a and 108a to converse with each other.

In use, a passenger seated in chair 122 may swivel to a wide range of positions, for example, facing the front of airplane 100, facing ottoman 124, or facing a window of airplane 100. Chair 122 may be releasably lockable in these and/or other positions, and may include detents to releasably lock chair 122 into such positions. Similarly, a passenger seated in chair 132 may face a number of directions, for example, towards the front of airplane 100, towards ottoman 134, or towards a divider between passenger compartments 102b and 102c. If divider 146 is removed, the passenger seated in chair 132 may face another passenger seated in recliner 108a, facilitating conversation between the passengers. Additionally, passengers seated in chairs 122 and 132 may swivel towards ottomans 124 and 134, respectively, and fully recline in chairs 122 and 132 to lie down on the surface formed by chairs 122 and 132 and ottomans 124 and 134, respectively.

FIGURE 2 is a perspective view of passenger compartments 106 c-d, 108 c-d, and 110 b-d according to the present invention. Each passenger compartment 106c-d through 110b-d comprises a recliner 220a-e, respectively, shown in the same or different positions as in FIGURE 1B. Passenger compartments 106c-d through 110b-d may also include tables, for example, side tables 226a-e and work tables 228a-e, and video monitors 230a-e coupled to passenger compartments 106c-d through 110b-d. Tables 226a-e and 228a-e and video monitors 230a-e are described in more detail in conjunction with FIGURES 4A through 4H.

Recliners 220a-e include chairs 232a-e and ottomans 234a-e, respectively. Chairs 232a-e of recliners 220a-c may be positioned in a variety of ways. For example, chair 232d is shown in an upright position facing forward in a direction parallel to centerline 103. Chair 232e is shown in an upright position and swiveled toward ottoman 234e and chair 232b is upright and swiveled towards a window 236. Chairs 232a and c are shown reclined and facing towards ottomans 234a and c, respectively, to form a generally horizontal surface on which a passenger may lie down.

Side tables 226a-e may be placed in an open position or a closed position. Side tables 226b and e are shown in an open position, and side tables 226a, c, and d are shown in a closed position. Work tables 228a-e may be placed in a stowed position, a folded position, or an open position. Work tables 228a and c are shown in a stowed position, work tables 228b and e are shown in a folded position, and work table 228d is shown in a open position. Video monitors 230a-e are described in more detail in conjunction with FIGURE 4A. Video monitors 230a-e may be stowed or upright. Video monitor 230a is in a stowed position, and video monitors 230b-e are in upright positions. Upright video monitors 230b-e may be positioned at a variety of angles.

In use, a passenger seated in chair 232a may face towards side table 226a or work table 228a. The passenger may sit upright in chair 232a, and another passenger may sit on ottoman 234a. Both passengers may use worktable 228a as, for example, a dining area. A passenger seated in chair 232a may position the chair

into a reclined position and lie down on the horizontal surface formed by chair 232a and ottoman 234a.

FIGURE 3A illustrates a side view of chair 122 in an upright position according to the present invention. Chair 122 includes a back 310 (shown in an upright position), a seat 312, armrests 314a-b (armrest 314b not explicitly shown), a base 316, a support 317, and a front piece 322 coupled together as shown. Back 310 may be reclined to a generally horizontal reclined position, as described in conjunction with FIGURE 3B. The back part of seat 312 may be coupled to the lower part of back 310. Seat 312 may be positioned such that the back part of seat 312 is lower than the front part when chair 122 is in an upright position. Seat 312 may move to a generally horizontal position when chair 122 is in a reclined position, as described in conjunction with FIGURE 3B.

Armrest 314a, coupled to seat 312, may include a recline switch 318 that may be used to place chair 122 in a reclined position. Armrests 314a-b may also include armrest latches 320 that may be used to raise or lower armrests 314a-b. Base 316 coupled to seat 312 may include an indicator 323 indicating that chair 122 is facing in a desired direction, for example, facing forward and parallel to centerline 103. Indicator 323 may comprise a gauge and a signal device, which may perform in a mechanical manner. Support 317 couples base 316 to the floor of airplane 100.

One end of front piece 322 may be coupled to seat 312. Front piece 322 may be in a generally vertical position when chair 122 is in an upright position, and may move to a generally horizontal position level with

seat 312 and ottoman 124 when chair 122 is in a reclined position, as described in more detail in conjunction with FIGURE 3B.

FIGURE 3B is a side view of chair 122 of FIGURE 3A in a reclined position. Back 310 may be lowered to a position where back 310 is generally horizontal and at approximately the same height as seat 312. Chair 122 may move towards ottoman 124, relative to support 317, so that when chair 122 fully reclines it forms a continuous bed with ottoman 124.

Reclining may take place, for example, by pressing a button which begins reclining of chair 122. At various points during the reclining procedure, the following may occur. Seat 312 moves from a position where the back of seat 312 is lower than the front of seat 312 to a position where seat 312 is generally horizontal. One or both armrests 314a-b may be lowered to generally the level of seat 312. Front piece 322 is raised to a generally horizontal position at approximately the same height as seat 312 and ottoman 124. Base 316 moves with respect to support 317 towards ottoman 124, until front piece 322 touches ottoman 124 and may move on a track within chair 122. The movement is illustrated by the relative positions of base 316 and support 317 in FIGURES 3A and 3C. Back 310, seat 312, armrests 314a-b, front piece 322, and ottoman 124 in a reclined position may form a generally horizontal surface of, for example, approximately seventy-eight inches, on which a passenger may lie down. This procedure may be reversed by pressing the same or an alternative button to bring chair 122 to an upright position.

FIGURE 3C is a front view of chair 122 of FIGURE 3A. Chair 122 may also include a seatbelt 324. Indicator 323 may be visible from the front of chair 122.

FIGURE 3D is a perspective view of indicator 323 of chair 122 of FIGURE 3A. Indicator 323 is located generally inside of chair 122, where a signal device 340 may be visible from the outside of chair 122 when chair is in a desired position, for example, a forward position. Signal device 340 is coupled to a curved bracket 342. A base bracket 346 is coupled to support 317 of chair 122. Support 317 remains generally stationary with respect to the floor of airplane 100. Curved bracket 342 and base bracket 346 are coupled to a retracting device, for example, a spring 348. Curved bracket 342 and base bracket 346 may move relative to each other from a first position to a second position, and spring 348 may move curved bracket 342 and base bracket 346 from the second position back to the first position. Curved bracket 342 may come in contact with a base plate 350, which moves in a generally rotating motion as chair 122 swivels. Base plate 350 has a projection 351.

In operation, as chair 122 swivels towards a forward position, base plate 350 also moves. Projection 351 of base plate 350 applies force to curved bracket 342. At some point of the swiveling, the force causes signal device 340 to move where it is visible from the outside of chair 122 to indicate that chair 122 is in the desired position. Chair 122 may be releasably locked in the desired position. As chair 122 swivels away from the forward position, projection 351 applies less force to

curved bracket 342. Spring 348 applies force to curved bracket 342 to retract signal device 340, indicating that the chair is not in the desired position.

FIGURES 4A through 4H are drawings of passenger compartment 110c showing additional details of the compartment from various views. FIGURE 4A is a perspective view of passenger compartment 110c according to the present invention. Passenger compartment 110c may include tables, for example, side table 226b and work table 228b, and may also include ottoman 234b, which is described in more detail in conjunction with FIGURES 5A through 5D, and video monitor 230b. Side table 226b, work table 228b, ottoman 234b, and video monitor 230b may be coupled to a side of passenger compartment 110c and/or to partition 112. Passenger compartment may also include vent gratings 420 (only one is explicitly shown) that may be used to circulate air within passenger compartment 110c. A drawer 408 may be coupled to side table 226b to provide storage space, and may be located to one side of side table 226b, as shown, or located in other suitable positions, such as centered below side table 226b. Partition 112 may be used to separate passenger compartment 110c from an adjoining passenger compartment.

FIGURE 4B is another perspective view of passenger compartment 110c of FIGURE 4A. Partition 112 may include a recliner support 411. Recliner support 411 may provide support for a recliner of passenger compartment 110c and may provide additional room for an adjoining passenger compartment. Divider 146 may be used to provide privacy for a passenger in passenger compartment 110c. Divider 146 may also be removed to allow a

passenger in passenger compartment 110c to converse with a passenger in an adjoining passenger compartment. Electrical panel 510 may, for example, communicate electrical and/or data signals and may include, for example, a data modem, an electrical outlet, a headset jack, and a dimmer switch. A personal video player 512 may also be included.

FIGURE 4C is a top view of passenger compartment 110c of FIGURE 4A. Work table 228b may include two parts 415a-b coupled together by hinges 409a-b, or by other coupling devices. Work table 228b may be placed in an open position where part 415a is next to part 415b forming a generally horizontal plane. In an open position, work table 228b may provide a table area for a passenger seated in a chair of passenger compartment 110c and on ottoman 234b. Work table 228b may also be placed in a closed position, where part 415a is on top of the part 415b. Work table 415 may also be placed in a stowed position, where parts 415a-b are folded together and stored in compartment 419.

FIGURE 4D is another top view of passenger compartment 110c of FIGURE 4A. Side table 226b may comprise two parts 413a-b coupled together by, for example, hinges 417a-b or other coupling devices. In an open position, part 413a may be positioned next to part 413b forming a generally horizontal plane. In a closed position, part 413b is folded towards part 413a until part 413b is on top of part 413a.

FIGURE 4E is a side view of passenger compartment 110c of FIGURE 4A along line 4E-4E of FIGURE 4A. Vent

gratings 420 may be coupled to a wall of passenger compartment using screws 424 or other fastening devices.

FIGURE 4F is a side view of passenger compartment 110c of FIGURE 4A along line 4F-4F of FIGURE 4A. Work table 228b is shown in an upright position to display the underside of work table 228b. Hinges 444 or other coupling devices may be used to couple worktable 228b to a wall of passenger compartment 110c, and hinges 446 may be used to support work table 228b.

FIGURE 4G is a left end view of passenger compartment 110c of FIGURE 4A.

FIGURE 4H is a right end view of passenger compartment 110c of FIGURE 4A. Ottoman 234b may be coupled to a partition (not explicitly shown) using brackets 450 and screws 452.

FIGURE 5A is a perspective view of ottoman 234b of FIGURE 4A according to the present invention. Ottoman 234b may comprise two parts, for example, an outer part 502 and an inner part 504; however, ottomans comprising more or fewer parts may be used. Ottoman 234b may be used for resting a passenger's feet, for seating a passenger, for completing a bed in combination with chair 232b, or for other suitable purposes.

FIGURE 5B is an underside view of ottoman 234b of FIGURE 5A. Outer part 502 may be coupled to partition 112 using brackets 506a-b and 508a and screws 510a-b and 512a or other coupling devices. Outer part 502 may be coupled to partition 112 using a bracket 508b and screws 512b or other coupling devices. Brackets 508a-b may also be used to align outer part 502 with inner part 504. Other aligning devices, however, may be used to align

outer part 502 with inner part 504. Inner part 504 may be rotated relative to outer part 502 about pins 514a-b. Brackets 516a-b and screws 518a-b may provide support for pins 514a-b.

FIGURE 5C is a cross-section view of ottoman 234b of FIGURE 5B along line 5C-5C. Pin 514a couples outer part 502 with inner part 504, allowing inner part 504 to rotate with respect to outer part 502. Inner 504 and outer 502 parts may include indentations 520a-b, respectively, that receive pin 514a to couple parts 502 and 504.

FIGURE 5D is a cross-section view of ottoman 234b of FIGURE 5B along line 5D-5D. Inner part 504 includes indentation 520a that may receive pin 514a.

Embodiments of the present invention provide numerous technical advantages. For example, a technical advantage of one embodiment of the present invention is that a passenger cabin may provide many passenger compartments. Each passenger compartment may have a recliner that allows a passenger to swivel and fully recline. Two tables may be available in each passenger compartment. Two passengers may be comfortably seated at one of the tables in the passenger compartment. A partition may be used to separate one passenger compartment from an adjoining passenger compartment, and may allow passengers in both compartments to comfortably recline. Another technical advantage of one embodiment of the present invention is that the passenger may face forward during take-off and landing in accordance with FAA regulations. An indicator may be used to indicate that the passenger is facing in the forward direction.

Consequently, the present invention may result in more efficient and more comfortable seating of passengers in a transportation system.

Although an embodiment of the invention and its advantages are described in detail, a person skilled in the art could make various alternations, additions, and omissions without departing from the spirit and scope of the present invention as defined by the appended claims. For example, the invention has been described in the particular context of seating a passenger on an airplane. The teachings of the invention are applicable to other types of travel.

WHAT IS CLAIMED IS:

1. An airplane comprising:

a column of recliners within the airplane, each recliner comprising:

an ottoman; and

a chair detached from the ottoman, the chair releasably lockable in a first angular position and rotatable to a second angular position generally facing the ottoman.

2. The airplane of Claim 1, wherein the column is a first column, the ottoman is a first ottoman, and the chair is a first chair, and a first angle is defined between the first angular position and the second angular position, and further comprising:

a second column of recliners within the airplane, each recliner comprising:

a second ottoman; and

a second chair detached from the second ottoman, the second chair releasably lockable in a third angular position and rotatable to a fourth angular position generally facing the second ottoman, wherein a second angle is defined between the third angular position and the fourth angular position, and the second angle is approximately equal in magnitude and opposite in direction of the first angle.

3. The airplane of Claim 1, wherein the ottoman is configured to allow seating of a passenger on the ottoman.

4. The airplane of Claim 1, wherein the chair in the first angular position faces generally towards a front of the airplane.

5. The airplane of Claim 1, wherein the chair is rotatable to a third angular position generally perpendicular to the first angular position and generally facing a window of the airplane.

6. The airplane of Claim 1, wherein the chair is rotatable to a third angular position generally perpendicular to the first angular position and generally facing a first table, thereby allowing use of the first table.

7. The airplane of Claim 1, wherein the second angular position generally faces a second table, thereby allowing use of the second table.

8. The airplane of Claim 1, wherein the second angular position generally faces a second table, thereby allowing use of the second table.

9. The airplane of Claim 1, wherein the second angular position generally faces a second table, the second table storable in a compartment.

10. The airplane of Claim 1, wherein the chair is rotatable to a third angular position generally perpendicular to the first angular position and generally facing a divider.

11. The airplane of Claim 1, wherein the chair is rotatable to a third angular position generally perpendicular to the first angular position and generally facing another recliner, thereby allowing communication between adjacent passengers.

12. The airplane of Claim 1, wherein the chair comprises:

a seat; and

a back coupled to the seat and reclinable to a position generally parallel to the seat.

13. The airplane of Claim 12, wherein the seat has an upper surface, and further comprising an armrest coupled to the seat, the armrest having an upper surface and retractable to a position where the upper surface of the armrest is generally flush with the upper surface of the seat.

14. The airplane of Claim 13, wherein the seat has an upper surface, and further comprising two armrests coupled to the seat, each armrest having an upper surface and retractable to a position where the upper surface of the armrest is generally flush with the upper surface of the seat.

15. The airplane of Claim 1, wherein the column comprises four recliners.

16. The airplane of Claim 1, wherein the column is a port column and further comprising a starboard column of recliners within the airplane.

17. The airplane of Claim 16, further comprising a first center column of recliners within the airplane.

18. The airplane of Claim 17, further comprising a second center column of recliners within the airplane.

19. The airplane of Claim 1, further comprising an indicator coupled to the chair and indicating that the chair is locked in a desired position.

20. The airplane of Claim 1, further comprising an indicator coupled to the chair and indicating that the chair is locked in the first angular position.

21. A system for passenger seating, the system comprising:

a first recliner comprising:

a first ottoman; and

a first chair detached from the first ottoman, the first chair releasably lockable in a first angular position and rotatable to a second angular position generally facing the first ottoman, wherein a first angle is defined between the first angular position and the second angular position; and

a second recliner detached from the first recliner and comprising:

a second ottoman; and

a second chair detached from the second ottoman, the second chair releasably lockable in a third angular position and rotatable to a fourth angular position generally facing the second ottoman, wherein a second angle is defined between the third angular position and the fourth angular position, the first angle and the second angle approximately equal in magnitude.

22. The system of Claim 21, wherein the first recliner and the second recliner are in a common row of recliners.

23. The system of Claim 22, further comprising a divider between the first recliner and the second recliner, the divider separating the first recliner from the second recliner.

24. The system of Claim 23, wherein the divider is removable.

25. The system of Claim 21, wherein the first recliner and the second recliner are in a common column of recliners.

26. The system of Claim 25, further comprising a partition between the first recliner and the second recliner, the partition separating the first recliner from the second recliner.

27. The system of Claim 21, wherein the ottoman is configured to allow seating of a passenger on the ottoman.

28. The system of Claim 21, wherein the chair in the first angular position faces generally towards a front of the airplane.

29. The system of Claim 21, wherein the chair is rotatable to a third angular position generally perpendicular to the first angular position and generally facing a window of the airplane.

30. The system of Claim 21, wherein the chair is rotatable to a third angular position generally perpendicular to the first angular position and generally facing a first table, thereby allowing use of the first table.

31. The system of Claim 30, wherein the second angular position generally faces a second table, thereby allowing use of the second table.

32. The system of Claim 21, wherein the second angular position generally faces a second table, thereby allowing use of the second table.

33. The system of Claim 21, wherein the second angular position generally faces a second table, the second table storable in a compartment.

34. The system of Claim 21, wherein the chair is rotatable to a third angular position generally perpendicular to the first angular position and generally facing a divider.

35. The system of Claim 21, wherein the chair is rotatable to a third angular position generally perpendicular to the first angular position and generally facing another recliner, thereby allowing communication between adjacent passengers.

36. The system of Claim 21, wherein the chair comprises:

a seat; and

a back coupled to the seat and reclinable to a position generally parallel to the seat.

37. The system of Claim 36, wherein the seat has an upper surface, and further comprising an armrest coupled to the seat, the armrest having an upper surface and retractable to a position where the upper surface of the armrest is generally flush with the upper surface of the seat.

38. The system of Claim 37, wherein the seat has an upper surface, and further comprising two armrests coupled to the seat, each armrest having an upper surface and retractable to a position where the upper surface of the armrest is generally flush with the upper surface of the seat.

39. The system of Claim 21, further comprising an indicator coupled to the chair and indicating that the chair is locked in a desired position.

40. The system of Claim 21, further comprising an indicator coupled to the chair and indicating that the chair is locked in the first angular position.

41. An indicator for a passenger seat, the indicator comprising:

a base plate operable to move as a passenger seat moves;

a signal device coupled to the base plate, wherein the base plate is operable to move the signal device and the signal device indicates that the passenger seat is facing in a desired direction.

42. The indicator of Claim 41, further comprising a retracting device operable to retract the signal device.

43. The indicator of Claim 41, wherein the base plate comprises a projection operable to move the signal device.

44. A passenger cabin comprising:

a first recliner comprising a first ottoman and a first chair;

a second recliner comprising a second ottoman and a second chair, wherein the second chair is spaced from the first chair in a first angular position and the second chair is spaced from the second ottoman in a second angular position; and

a partition separating the first recliner from the second recliner.

45. The passenger cabin of Claim 44, wherein an angle between the first angular position and the second angular position is greater than ten degrees.

46. The passenger cabin of Claim 44, wherein the first chair is spaced from the second chair in a third angular position and the first chair is spaced from the second chair in a fourth angular position, the fourth angular position generally perpendicular to the third angular position.

47. The passenger cabin of Claim 44, wherein the partition comprises a removable partition.

48. The passenger cabin of Claim 44, further comprising a recliner support formed from the partition, the recliner support supporting the first recliner.



INVESTOR IN PEOPLE

Application No: GB 0111079.0
Claims searched: 1-40 & 44-48

30

Examiner: David J Evans
Date of search: 16 July 2001

Patents Act 1977 Search Report under Section 17

Databases searched:

UK Patent Office collections, including GB, EP, WO & US patent specifications, in:

UK Cl (Ed.S): A4L (LABB, LBBA, LBLA, LBMB); B7W (WFE)

Int Cl (Ed.7): B60N (2/005, 2/01, 2/34); B61D (33/00); B64D (11/06)

Other: Online: EPODOC, WPI & PAJ.

Documents considered to be relevant:

Category	Identity of document and relevant passage	Relevant to claims
A	GB 2295962 A (BRITISH AIRWAYS) document of general interest, see whole document.	-
A	WO 00/21831 A1 (BRITISH AIRWAYS) whole document of interest, in particular refer to figs 1-4, page 1 lines 27-30, page 2 lines 1-13 & 18-22, page 17 lines 3-8, page 20 lines 18-22 and abstract.	-
A	US 5954401 A (KOCH) of overall interest, see whole document.	-
A	JP 11152094 A (NIPPON AEROPLANE KK) see figs 1-3 and abstract translation.	-

X Document indicating lack of novelty or inventive step
 Y Document indicating lack of inventive step if combined with one or more other documents of same category.
 & Member of the same patent family

A Document indicating technological background and/or state of the art.
 P Document published on or after the declared priority date but before the filing date of this invention.
 E Patent document published on or after, but with priority date earlier than, the filing date of this application.