



(22) Date de dépôt/Filing Date: 2012/01/13

(41) Mise à la disp. pub./Open to Public Insp.: 2013/07/13

(45) Date de délivrance/Issue Date: 2021/02/16

(51) Cl.Int./Int.Cl. *G21C 13/02* (2006.01),  
*G21C 13/00* (2006.01), *G21C 19/20* (2006.01)

(72) Inventeurs/Inventors:  
KING, JAMES M., CA;  
ADAMS, PAUL G., CA

(73) Propriétaire/Owner:  
ATOMIC ENERGY OF CANADA LTD., CA

(74) Agent: GOWLING WLG (CANADA) LLP

(54) Titre : PATIN D'ESPACEMENT POUR CANAL DE COMBUSTIBLE

(54) Title: FUEL CHANNEL SPACER SYSTEM AND METHOD

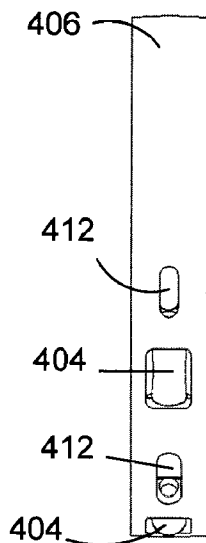

(57) Abrégé/Abstract:

The present invention relates to a spacer for maintaining a distance between a pressure tube and a calandria tube in a nuclear reactor, and more specifically, to a spacer which is secured in position between the pressure tube and calandria tube. The axial position of the spacer is maintained by having a spacer with an outer profile that is in close fit or a slight interference fit with a locally expanded profile of the calandria tube. A spacer, a corresponding calandria tube, and a method for installing such a spacer are described.

## ABSTRACT

The present invention relates to a spacer for maintaining a distance between a pressure tube and a calandria tube in a nuclear reactor, and more specifically, to a spacer which is secured in position between the pressure tube and calandria tube. The axial position of the spacer is maintained by having a spacer with an outer profile that is in close fit or a slight interference fit with a locally expanded profile of the calandria tube. A spacer, a corresponding calandria tube, and a method for installing such a spacer are described.

## FUEL CHANNEL SPACER SYSTEM AND METHOD

### FIELD OF INVENTION

[0001] The present invention relates to a spacer for maintaining an inner tube in spaced relation within an outer tube and in particular to a spacer for maintaining a distance between a pressure tube and a calandria tube in a nuclear reactor. The invention is particularly concerned with a spacer which is secured in position between the pressure tube and calandria tube, and a spacer with simple installation and replacement.

### BACKGROUND OF THE INVENTION

[0002] Referring to **Figures 1 and 2**, one of the major components of a nuclear reactor is a calandria vessel 100 - a large, sealed tank, in which the nuclear reaction takes place. The calandria 100 is penetrated by many tubes (i.e. calandria tubes 102) allowing uranium or similar fuel bundles or rods 104 to be inserted into the calandria 100 via fuel channels, and allowing pressure tubes 106 to draw heat to feed the generation system. In a CANDU™ reactor, a fuel channel consists of a 104 mm diameter, 4.3 mm thick zirconium alloy pressure tube 106, inserted into a calandria tube 102 of a slightly larger diameter, with two stainless steel end fittings 110 at the ends of the fuel channel. Several hundred calandria tubes 102, approximately 6.3 m long, are horizontally mounted in the calandria: 100.

[0003] The annular gap between the pressure tubes 106 and calandria tubes 102 are filled with CO<sub>2</sub> gas which acts as an insulator between the “hot” pressure tube and the heavy water moderator 112 in the calandria vessel 100. Heavy water 112 flows through the pressure tubes, 106, removing heat from the fuel bundles 104 and transferring it to steam generators, where secondary circuit light water 116 is heated and converted into steam 118 to run a turbine. The balance of the components shown in Figures 1 and 2 (i.e. the control rods 120, heat exchanger 122, light water pump 124, heavy water pump

126, concrete shielding 128, closure plugs 130, end shield 132, etc.) vary from one reactor design to the next.

[0004] During reactor operation, pressure tube 106 material is subject to high pressure (up to 11.3 MPa), high temperature (up to 310° C) and very high gamma and neutron radiation fields. The calandria tubes 102 are subjected to head pressure (from the heavy water moderator 112 located in the calandria 100). As the inner pressure tube 106 operates at a relatively high temperature and the outer calandria tube 102 operates at a much lower temperature, fuel channels in a nuclear reactor, such as a CANDU™ reactor, require an annular space to be maintained between the pressure tube 106 and the coaxial calandria tube 102 in order to maintain the temperature differential, to allow for the circulation of gases which thermally insulate the hot pressure tube 106 from the relatively colder calandria tube 102 and the heavy water moderator 112 which flows in the space outside the calandria tube.

[0005] However, the weight of the fuel 104 and coolant inside the pressure tube 106 would cause it to sag into contact with the calandria tube 102 if it were not supported at a few discrete points along its span. Annulus spacers 114 are designed for transmitting supporting force and maintaining the required gap between the pairs of calandria tubes 102 and pressure tubes 106.

[0006] Therefore, annulus spacers 114 are an important component that makes up a reactor fuel channel. These spacers 114 maintain the radial spacing between the two coaxial tubes (the inner pressure tube 106 and the outer calandria tube 102) and help the calandria tubes 102 to support pressure tubes: 106. Typically, four spacers 114 are used in each fuel channel, each at a different axial position. To provide the required support of the pressure tube 106, the annulus spacers 114 must be located at the proper position. If a spacer 114 is out of position, the hot pressure tube 106 may come into contact with the cooler calandria tube 102, which is unacceptable in the reactor.

[0007] Conventionally, garter spring spacers have been used to maintain the space between the pressure tube 106 and the calandria tube 102. A garter spring spacer is basically a helical spring disposed around the pressure tube 106. Its convolutions contact the walls of both the pressure tube 106 and the calandria tube 102. The spring is unattached to either tube. A garter spring spacer was disclosed in United States Patent No. 3,106,520 issued to Wolfe et al. October 8, 1963.

[0008] Two types of such garter spring spacers have been used in CANDU™ fuel channels, known as the loose-fit spacer 302 and the snug-fit spacer 304. Their arrangements are shown in **Figure 3**. Both garter spring spacers 302, 304 comprise a closely coiled spring made from a square cross-section wire, assembled on a circular girdle wire to form a torus. The design of the garter spring spacers 302, 304 is such that they are not fixed rigidly in position. Thus, it is possible that a garter spring spacer 302, 304 may move out of position.

[0009] The loose-fit garter spring spacer 302 does not reliably remain in its installed location. The loose-fit garter spring spacer 302 relies on friction to maintain position. Some loose-fit garter spring spacers 302 move axially away from their intended positions during reactor operation thereby causing a major source of concern, as the spacers 114 must stay in their intended positions to ensure that the pressure tube 106 is adequately supported and remains out of contact with the calandria tube 102. The loose-fit garter spring design 302 has been replaced with the snug-fit garter spring design 304 for better performance in maintaining its axial position along the fuel channel.

[0010] The snug-fit garter spring spacer 304 has been shown to be more reliable in maintaining its installed location in the reactor. This is initially done by spring tension on the pressure tube 106. Over time the spring tension decreases and the garter spring spacer 304 becomes pinched between the pressure tube 106 and calandria tube 102, which aides in keeping the snug-fit garter spring spacer 304 in position through friction.

The snug-fit garter spring spacer 304 is typically made using Inconel X-750 for the helical spring coil and Zircaloy-2 for the girdle wire. Inconel X-750 is a nickel-based alloy, and it was chosen in part for its ability to maintain the required spring tension under the given operating conditions. However, it has been discovered that the mechanical properties of nickel-based alloys degrade with prolonged exposure to radiation, causing concerns about the condition of the Inconel garter springs over time.

[0011] An additional drawback is that the snug-fit garter spring spacer 304 is difficult to detect to confirm its position. Loose-fit garter spring spacers 302 can be detected relatively easily using eddy current technology by detecting an induced current in the welded girdle wire 306. The snug-fit garter spring spacer 304 cannot be detected using the eddy current technique because it does not have a continuous uninterrupted circuit around its perimeter, as its girdle wire 308 is not welded; it simply overlaps itself as it passes 1.5 times around the pressure tube 106. Techniques based on inspecting for pressure tube 106 deformation (sag, ovality, pressure tube-to-calandria tube gap) have been used to indirectly identify spacer 114 position. However, techniques using pressure tube deformation as a measure of spacer position have the disadvantage that they only indicate where a spacer has once resided, but not necessarily where a spacer is currently. This is because the pressure tube deformation does not immediately change with a change in spacer position. Recently, a vibration-based technique (termed MODAR™ for MODal Detection And Repositioning) has been developed to detect snug-fit garter spring spacer 304 position by monitoring the effect the spacer load has on controlled pressure tube vibrations.

[0012] Thus, neither the loose-fit nor snug-fit garter spring spacers 302, 304 are positively located in the fuel channel. In fact, the garter spring spacers 302, 304 are designed to roll when relative axial motion occurs between the pressure tube 106 and calandria tube 102 due to thermal changes and creep, so their position changes under operating conditions. This characteristic that the garter spring spacer 302, 304 position is not fixed results in Nuclear Regulators requiring that reactor operators perform

inspections to verify spacer 114 position. These inspections add cost and decrease operating efficiency of the reactor.

[0013] When a change to the spacer axial location occurs, the spacer 114 must be repositioned. Repositioning the spacers 114 is difficult and costly, and may also result in radiation exposure to those who conduct the procedure.

[0014] Further, because garter spring spacers 302, 304 are not attached to either the pressure tube 106 or the calandria tube 102, they must be installed on the pressure tube 106 after the pressure tube 106 has been placed inside the calandria tube 102. As a result, installation of the garter spring spacers 302, 304 is a challenging procedure which requires tedious operations to be carried out at the reactor face. The problem is exacerbated over the operating time of the fuel channel as increased sag develops in the calandria tubes 102. Spacer installation in a sagged fuel channel is significantly more challenging than in a straight fuel channel.

[0015] The difficulty in installing the spacers 114 is of particular significance to the fuel channel replacement procedures because when a fuel channel is replaced, the spacers 114 must be re-installed. Consequently, this adds to the time and cost of fuel channel replacement. An improved fuel channel spacer replacement procedure is desirable not only to reduce the time and expense of the operation but also to reduce the radiation dose level to which those who replace the fuel channels may be exposed.

[0016] It would also be desirable to use only low-neutron cross-section material, such as zirconium alloy, in a spacer design, instead of Inconel, to reduce fuel burn-up and increase neutron efficiency.

[0017] There is therefore a need for an improved spacer which is positioned between the pressure tube and calandria tube. It is also desirable that the improved spacer overcomes some of the difficulties inherent in the use of prior art spacers such as the garter spring spacer.

## SUMMARY OF THE INVENTION

[0018] It is an object of the invention to provide an improved spacer design and in particular, to provide a spacer design that is fixed in space and cannot be easily moved out of position, and that can be easily installed and/or replaced.

[0019] Presently, none of the prior art fuel channel annulus spacers are 'positively' located in the fuel channel (i.e. there are no physical features that keep the spacers in position or prevent them from moving out of position). When spacers move away from their intended positions during reactor operation, a major concern arises as to whether the pressure tube is adequately supported and remains out of contact with the calandria tube.

[0020] According to an aspect of the present invention there is provided a spacer for maintaining a pressure tube in spaced relation with a calandria tube in a nuclear reactor, wherein an outer profile of the spacer has a close fit with a locally, circumferentially-expanded profile of the calandria tube. This prevents axial movement of the spacer within the calandria tube.

[0021] According to another aspect of the present invention there is provided a calandria tube in a nuclear reactor comprising a locally, circumferentially-expanded profile for securing a spacer.

[0022] According to a further aspect of the present invention there is provided a method of installing a spacer in a nuclear reactor, comprising the steps of: positioning the spacer at an end of a calandria tube, the spacer being rotated 90 degrees out of installed position about its vertical axis; inserting the spacer into the calandria tube to align axially with a formed profile of the calandria tube; rotating the spacer 90 degrees about its vertical axis to engage with the formed profile of the calandria tube, and inserting the pressure tube through the calandria tube and spacer, fixing the axial position of the spacer.

[0023] Other systems, methods, features and advantages of the invention will be, or will become, apparent to one with skill in the art upon examination of the following figures and detailed description. It is intended that all such additional systems, methods, features and advantages be included within this description, be within the scope of the invention, and be protected by the following claims.

#### BRIEF DESCRIPTION OF THE DRAWINGS

[0024] These and other features of the invention will become more apparent from the following description in which reference is made to the appended drawings wherein:

Figure 1 presents a schematic diagram of a nuclear reactor as known in the art;

Figure 2 presents a simplified diagram of a calandria and immediately related components as known in the art;

Figure 3 presents an arrangement of calandria tube, pressure tube and garter spring annulus spacers as known in the art;

Figures 4A through 4C present side and front orthogonal, and isometric cutaway views, respectively, of the spacer in accordance with an embodiment of the present invention;

Figures 5A and 5B present the details and dimensions of the spacer body in accordance with an embodiment of the present invention;

Figures 6A through 6D present schematic views of the spacer installation process in an embodiment of the present invention; and

Figures 7A through 7D present isometric views of the spacer installation process in an embodiment of the present invention.

## DETAILED DESCRIPTION

[0025] One or more currently preferred embodiments have been described by way of example. It will be apparent to persons skilled in the art that a number of variations and modifications can be made without departing from the scope of the invention as defined in the claims.

[0026] As noted above, a problem with the prior art garter spring spacers 302, 304 is that they are not ‘positively’ located in the fuel channel, that is, there is nothing that physically keeps the prior art garter spring spacers 302, 304 in position or prevents them from moving out of position. Further, installation of the prior art garter spring spacers 302, 304 is a challenging procedure which requires additional operations to be carried out at the reactor face. Due to the above-described issues, there has been a long felt need in the industry for a new fuel channel spacer to replace the prior art garter spring spacers 302, 304. Several concepts have been proposed but heretofore, none have been successful. The new fuel channel annulus spacer design provided by the invention has been developed to address the performance shortcomings of the prior art garter spring type spacers 302, 304.

[0027] The current invention provides a novel spacer design that is positively located in space and cannot be easily moved out of position. It can also be easily installed and/or replaced. The spacer design also involves a change to the profile of the calandria tube 102 such that the revised profile is used to help fix the spacer position. Universal adoption will replace the prior art garter spring type fuel channel spacers 302, 304.

[0028] In the preferred embodiment of the invention, a novel and elegant solution to securing the position of the annulus spacer in the fuel channel is provided by capturing the spacer between the pressure tube 106 and a locally expanded section of calandria tube 102. With the system of the invention, fixing the spacer position requires no attachments (welds, threaded features, etc.) to either the pressure tube 106 or calandria tube 102. The locally expanded sections of the calandria tube 102 may be formed using

a known industrial process called hydroforming. This process uses hydraulic pressure to apply force to shape the calandria tube 102. In this case, a shaped die with the desired form is fit around the outside of the straight calandria tube 102 at the desired location and orientation. The die is split to allow it to be removed after hydroforming, and has a collar installed around it to hold it securely together during the expansion process. A type of plug is installed inside the calandria tube 102, coincident with the location of the die on the outside. At each end of the plug a seal is formed against the inside surface of the calandria tube 102. The plug includes appropriate ports to allow hydraulic fluid to be introduced into the sealed annulus between the plug and calandria tube 102. The fluid is then pressurized, which exerts enough force to cause the calandria tube 102 to expand outward against the formed die. The calandria tube 102 is left permanently deformed by this process. The jigs required would be specially made to fit the calandria tube 102 and to produce the desired shape. Generally it is not necessary to hydroform old calandria tubes; new calandria tubes are invariably used when building a new reactor or refurbishing an old reactor.

[0029] Note that with the expansion of the calandria tubes 102 to accommodate the new spacer design, the holes through the calandria vessel 100 generally do not have to be made larger. This is because the profile of the expanded section of calandria tube is designed such that it is within the envelope of the larger diameter belled ends that typically exist on the calandria tubes 102 (see 510 in Figure 5A). Thus, no modification to the calandria vessel 100 or the connection between the calandria and calandria tubes 102 is generally required by the new spacer design.

[0030] The preferred embodiment of the spacer design is shown in **Figures 4A through 4C**. The spacer 400 consists of a body 406 in the form of a generally cylindrical - or ring-shaped band, which is flattened on the two vertical sides (i.e. left side 408 and right side 410). The lower portion of the spacer body 406 provides support for a set of rollers- 404. The rollers 404 are secured to the body 406 using pins 402. In use, the spacer 400 is positioned inside the calandria tube 102 and the pressure tube 106 rests on the rollers

404. A roller-type support helps to minimize friction and possible wear when relative axial motion occurs between the pressure tube 106 and calandria tube 102. It also helps prevent displacement of the spacer 400 when a pressure tube 106 is being inserted into a calandria tube 102. The slots 412 in the spacer body 406 allow access to insert the pins 402 through the rollers 404.

[0031] The outer profile of the spacer body 406 is specifically designed to facilitate it being securely positioned inside the calandria tube 102 at locations where a special profile has been formed. The profile of the spacer body 406 is shown in the section view of **Figure 5A**. The outside dimension of the spacer 400 at the vertical and horizontal centerlines 502, 504 of its body approximately matches that of the inside diameter of the calandria tube 506. On the flattened vertical sides 408, 410 of the spacer 400, the width is maintained for a small distance above and below the horizontal centerline 504, producing the two flat portions shown in the section view. The curved portions 508 between the vertical centerline 502 and the flattened portions 408, 410 are sized to have a radius larger than the inside diameter of the calandria 506, and slightly smaller than the inside diameter of the locally expanded portion of the calandria tube 102 (see 602 in **Figure 6A**). In the embodiment described herein, the outside radius for this curved portion 508 is slightly larger than the standard nominal inside radius of a CANDU calandria tube of 2.54 inches. Thus, when the spacer 400 is in its final position within the expanded section 602, it will not be possible to displace the spacer 400 axially because of interference with the unexpanded calandria tube (see 604 in **Figure 6A**). The width of the flattened portions 408, 410 is determined simply by the amount desired to extend the outside spacer profile beyond the calandria tube body inside diameter 506 so as to secure it in place.

[0032] The actual three dimensional profile along the vertical side portion 408, 410 of the spacer 400 is cylindrical, with the cylindrical axis coinciding with the spacer centre. This rounded cross-section of the flattened portions 512, 514 is shown in the cross-sectional view of **Figure 5B**. Having the side flattened portions 408, 410

rounded, allows the spacer 400 to be rotated about its vertical axis 502 once the spacer 400 is in the locally expanded portion of the calandria tube 602, the curvature of the side flattened portions 408, 410 matching that of the expanded portion of the calandria tube 602. This profile also prevents the spacer 400 from rotating about either the axis of the calandria tube 102 or about a horizontal axis perpendicular to the calandria tube axis.

[0033] **Figures 6** and **7** illustrate the installation process, **Figures 6A** through **6D** presenting a schematic cross-sectional view from above, and **Figures 7A** through **7D** presenting isometric views.

[0034] To install the spacer 400, it is initially held vertically but rotated 90 degrees about the vertical axis from its installed position, at the end of the calandria tube 102, as shown in **Figures 6A** and **7A**. The spacer 400 is then inserted into the calandria tube 102 until it is aligned axially with the formed profile of the calandria tube (i.e. the expanded portion of the calandria tube 602) as shown in **Figures 6B** and **7B**.

[0035] The spacer 400 is then rotated 90 degrees about the vertical axis to engage it with the formed calandria tube 602 matching profile as shown in **Figures 6C** and **7C**. The flattened sides of the spacer 408, 410 are rounded so that their curvature matches the curvature of the expansion in the calandria tube 602, facilitating the easy rotation of the spacer 400 into its final position. The pressure tube 106 can then be installed in the calandria tube 102 and through the spacer 400. The presence of the installed pressure tube 106 prevents the spacer 400 from rotating about its vertical axis. With the pressure tube 106 installed, the spacer 400 is fully captured in place.

[0036] A significant feature of the invention is that the calandria tube 102 is locally formed (expanded) to allow the spacer 400 to be fixed in position. The formed calandria tube makes many alternate means of designing and fixing a spacer possible. For example, the spacer 400 could be hinged to expand into the formed shape and then be pinned in the opened configuration to fix it in place. The preferred embodiment

detailed above is provided for its simplicity of installation. However, other design variations based on the same approach of expanded forming of the calandria tube are also included in the scope of the invention.

[0037] The new spacer design has many advantages over the conventional designs. For example, it secures the spacer 400 in position by capturing it between the pressure tube 106 and calandria tube 102, therefore it physically keeps the spacer in position and prevents it from moving out of position. Further, the spacer 400 can be easily installed into position inside of the calandria tube- 102. There are no special attachment features that would need to be inspected or remotely manipulated. The spacer 400 can easily be removed and re-installed if needed for any practical reason.

[0038] A further advantage of the design of the spacer of the invention is that it is mechanically robust and does not require materials of construction to be chosen based on resistance to tension or any other requirement originating from the spacer design itself. The spacer 400 can therefore be made of zirconium alloys. This will reduce fuel burn-up and increase neutron efficiency for the reactor. Suitable oxide coating on the pins 402 and rollers 404 may be used to improve the wear characteristics of the design and reduce friction.

[0039] There is a huge economic advantage to producing an improved fuel channel annulus spacer as described in the present invention. The prior art garter spring spacers 304, 306 do not have a fixed position. This has caused concerns from Nuclear Regulators and has resulted in very large expenditures related to inspections and assessment of the effects of variations in spacer positions. The issues with the existing spacer design are widely known and are important considerations for potential buyers of nuclear reactors.

[0040] Implementation of the fuel channel annulus spacer design of the invention will improve the operating performance of reactors such as CANDU™ reactors and may

reduce the need for costly inspections. Of course, the new design may be applied to new build nuclear reactors and for refurbishment projects (i.e. reactor re-tubing).

#### OPTIONS AND ALTERNATIVES

[0041] Many variations to the described spacer are possible. Examples of variations include an alternate number of rollers (2 or 5 instead of 4), adding rollers 404 to the top portion of the spacer 400 in addition to the bottom, use of a solid bearing instead of a roller, altering the spacer installation axis away from vertical, changing the materials of construction, or using a hinge or latch feature to extend part of the spacer into the expanded calandria tube as a means to secure it in place.

#### CONCLUSIONS

[0042] One or more currently preferred embodiments have been described by way of example. It will be apparent to persons skilled in the art that a number of variations and modifications can be made without departing from the scope of the invention as defined in the claims.

WHAT IS CLAIMED IS:

1. A fuel channel spacer for maintaining a pressure tube in spaced relation with a calandria tube in a nuclear reactor, the fuel channel spacer comprising:  
a substantially cylindrical body having:
  - a first cross-sectional diameter which is less than or equal to an inside diameter of the calandria tube; and
  - a second cross-sectional diameter which is greater than the inside diameter of the calandria tube, but less than or equal to an inside diameter of a locally expanded profile of the calandria tube; anda plurality of bearing elements fixed to the substantially cylindrical body, arranged to support the pressure tube.
2. The fuel channel spacer of claim 1, wherein the first cross-sectional diameter comprises a vertical cross-sectional diameter of the substantially cylindrical body.
3. The fuel channel spacer of claim 2, wherein the second cross-sectional diameter comprises a cross-section of the substantially cylindrical body at an angle of  $\pm 45$  degrees from the vertical cross-sectional diameter.
4. The fuel channel spacer of any one of claims 1 to 3, wherein the second cross-sectional diameter is less than a cross-sectional diameter of a bell end of a calandria tube.
5. The fuel channel spacer of any one of claims 1 to 4, wherein the substantially cylindrical body includes flat portions on a left side and a right side of a front plan view, an outside measure between the left side flat portion and the right flat portion being less than the inside diameter of the calandria tube.
6. The fuel channel spacer of claim 5, wherein the left and right side flat portions have a horizontal cross-section which is cylindrical.
7. The fuel channel spacer of any one of claims 1 to 6, wherein the bearing elements comprise rollers.

8. The fuel channel spacer of claim 7, wherein the rollers are rotationally secured to the body using pins.
9. The fuel channel spacer of claim 8, wherein the rollers are located at a lower portion of the fuel channel spacer.
10. The fuel channel spacer of claim 9, comprising four rollers.
11. The fuel channel spacer of claim 10, wherein said substantially cylindrical body comprises slots to facilitate insertion of said pins into said rollers.
12. The fuel channel spacer of any one of claims 1 to 11, wherein the substantially cylindrical body is fabricated from zirconium.
13. A calandria tube for a nuclear reactor comprising a locally expanded profile for securing a fuel channel spacer as claimed in any one of claims 1 to 12.
14. The calandria tube of claim 13, wherein the locally expanded profile is cylindrical along straight vertical portions of the fuel channel spacer.
15. The calandria tube of claim 14, wherein the locally expanded profile comprises four variable-radius expanded portions, nominally centered at 45 degrees from vertical and horizontal axes, whose outer surface is radiused about a vertical centre line of the fuel channel spacer.
16. The calandria tube of claim 13 wherein the locally expanded profile is only cylindrical in an area that corresponds to vertical flat sections of the fuel channel spacer, centered at 3 and 9 o'clock positions, the locally expanded profile having a varied radius, centered on the fuel channel spacer vertical centerline, that matches a curved profile between side vertical flat sections and top and bottom locations coincident with the vertical centerline.

17. A method of installing a fuel channel spacer as defined in any one of claims 1 to 12, in a nuclear reactor, comprising the steps of:  
positioning the fuel channel spacer at an end of a calandria tube, the spacer being rotated 90 degrees out of an installed position about its vertical axis;  
inserting the fuel channel spacer into the calandria tube to align axially with a formed, expanded profile of the calandria tube;  
rotating the fuel channel spacer 90 degrees about its vertical axis to engage with the formed, expanded profile of the calandria tube; and  
inserting a pressure tube through the calandria tube and fuel channel spacer, fixing the axial position of the fuel channel spacer.

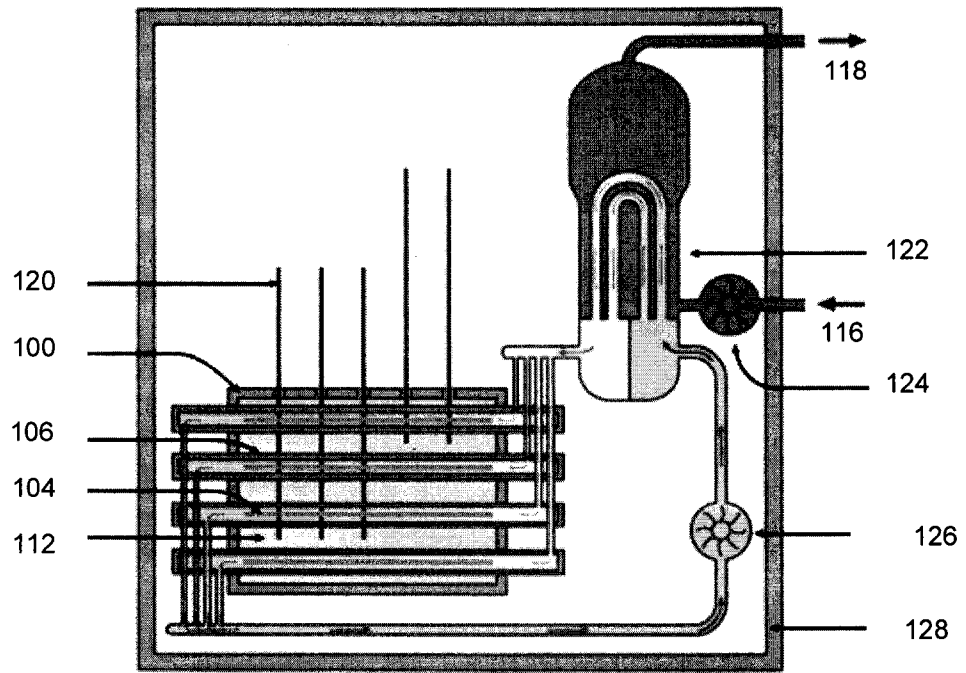

FIGURE 1 - PRIOR ART

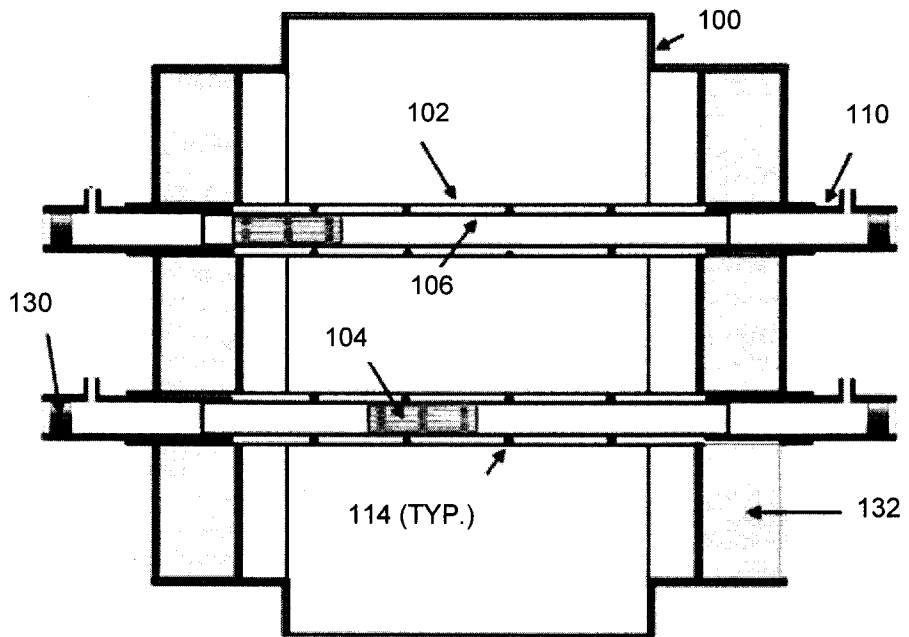

FIGURE 2 - PRIOR ART

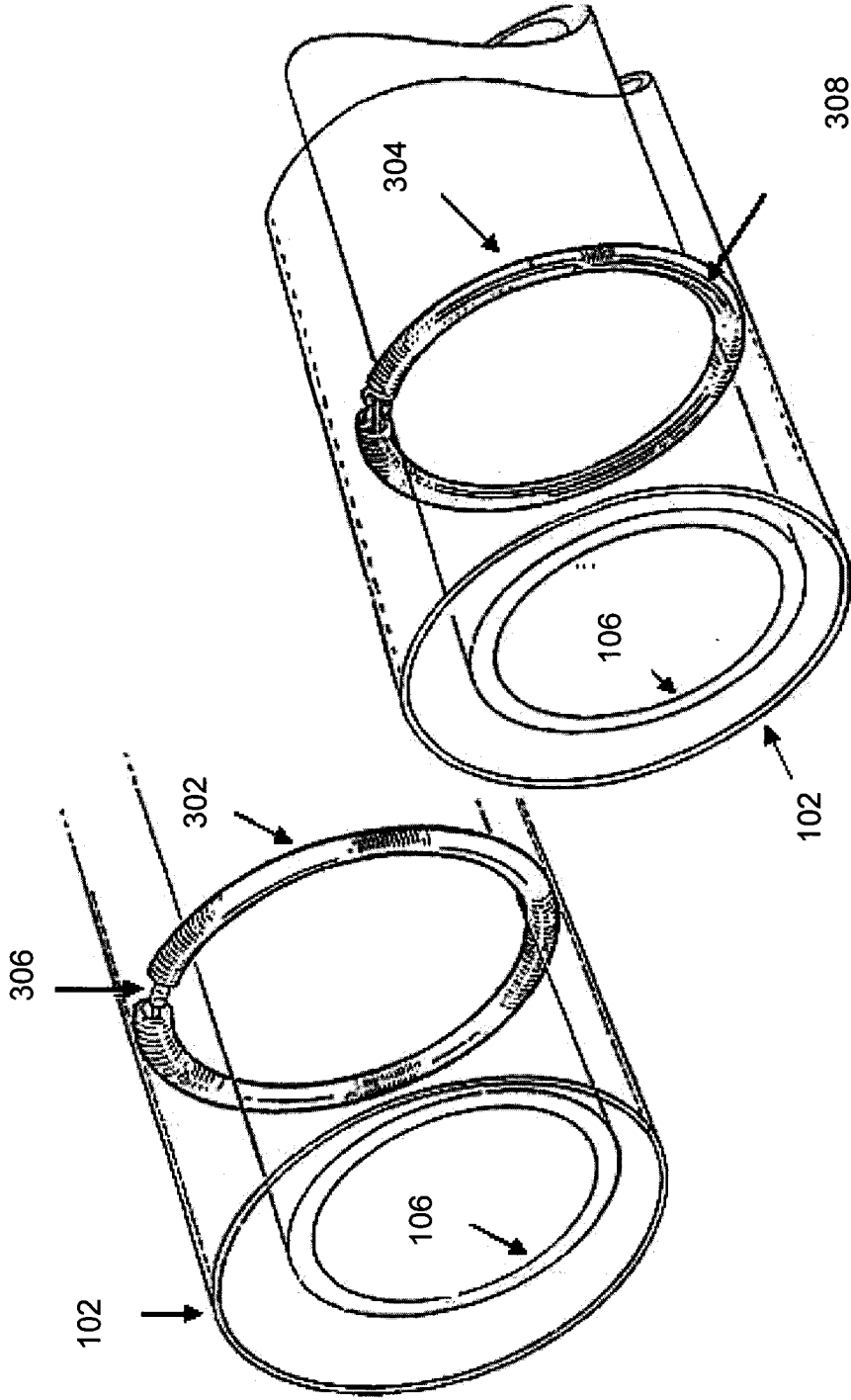

FIGURE 3 - PRIOR ART

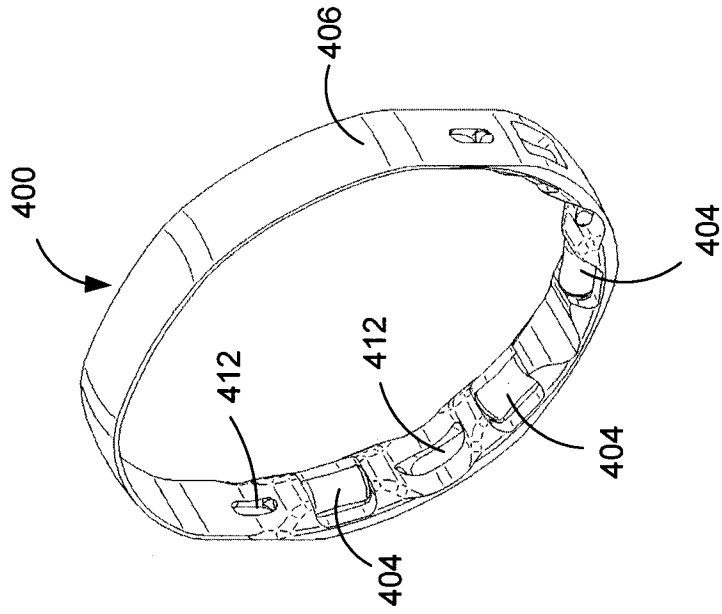

FIGURE 4C

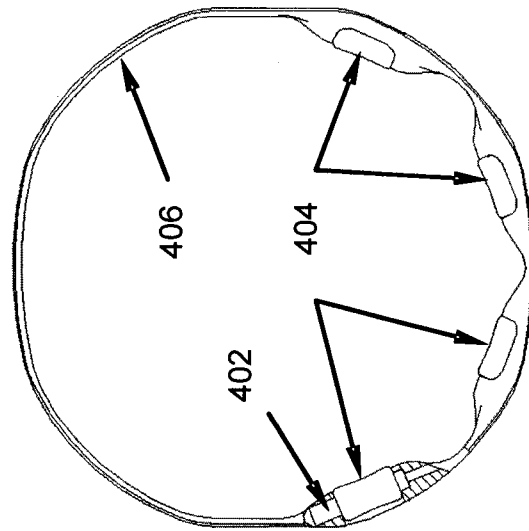

FIGURE 4B

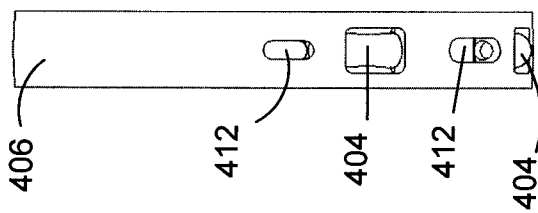

FIGURE 4A

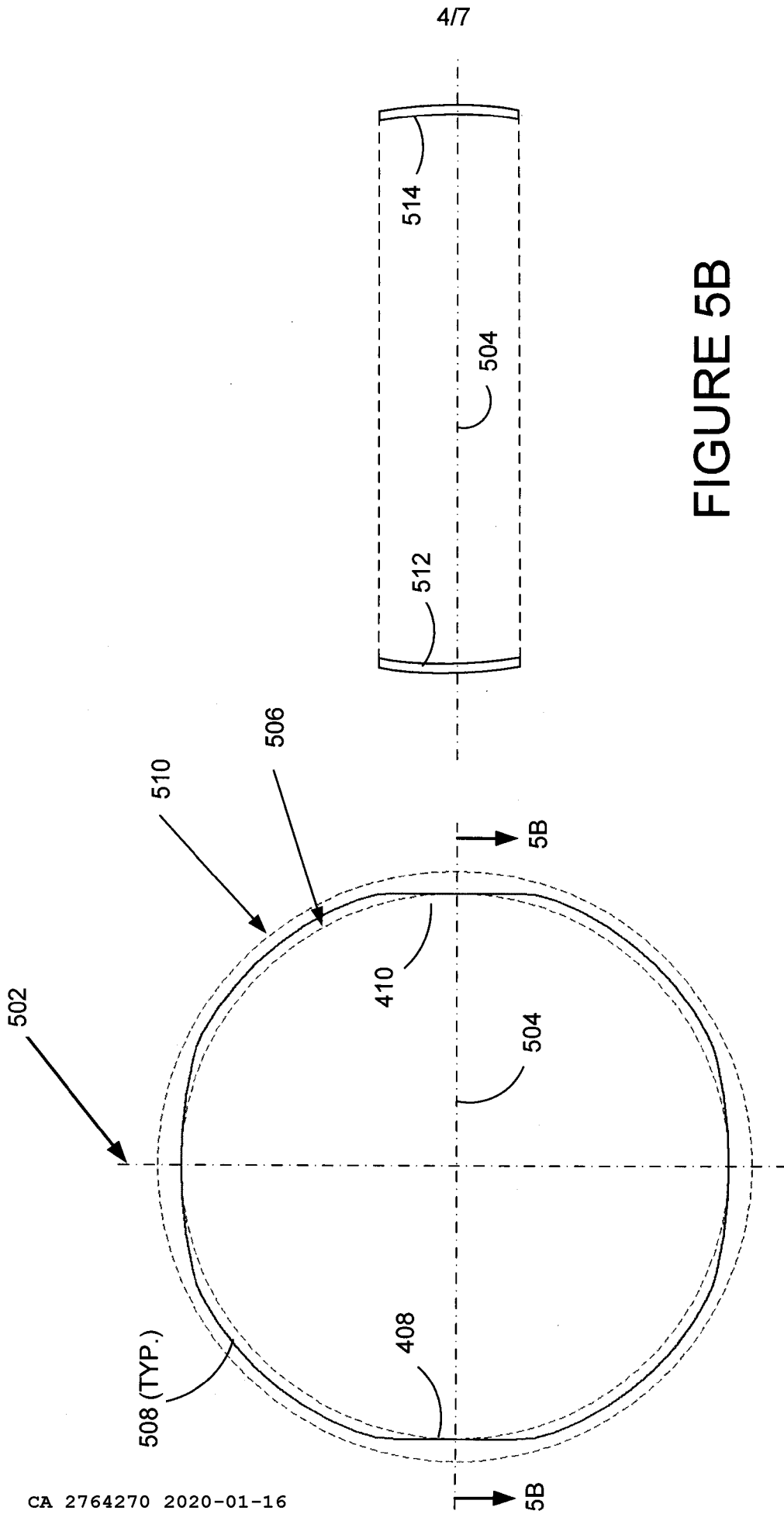

FIGURE 5B

FIGURE 5A

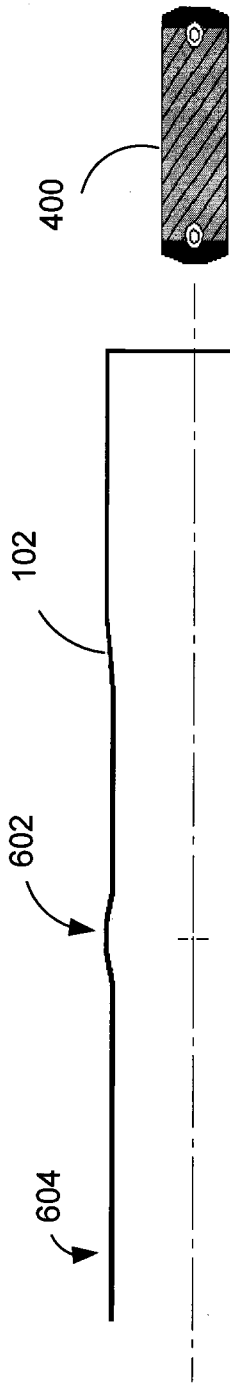

FIGURE 6A

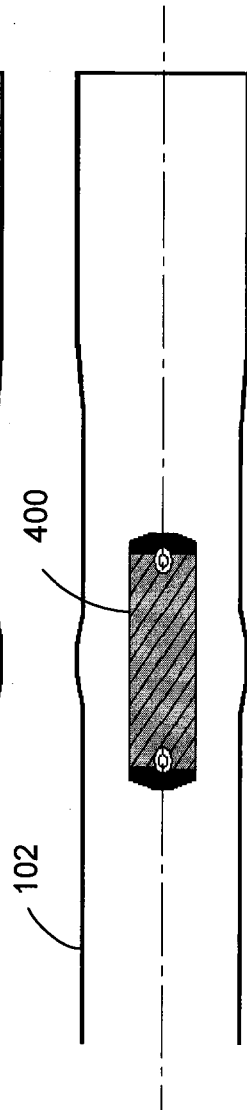

FIGURE 6B

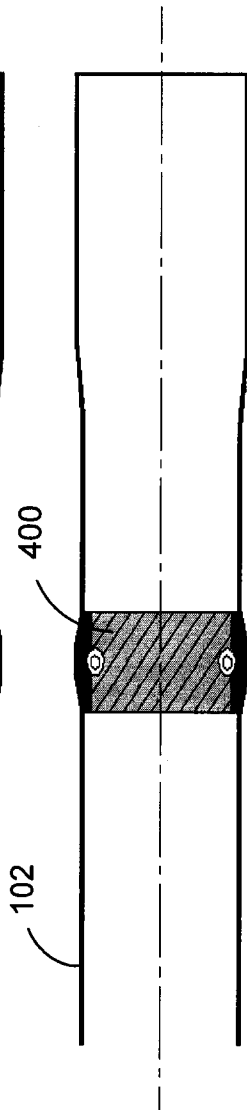

FIGURE 6C

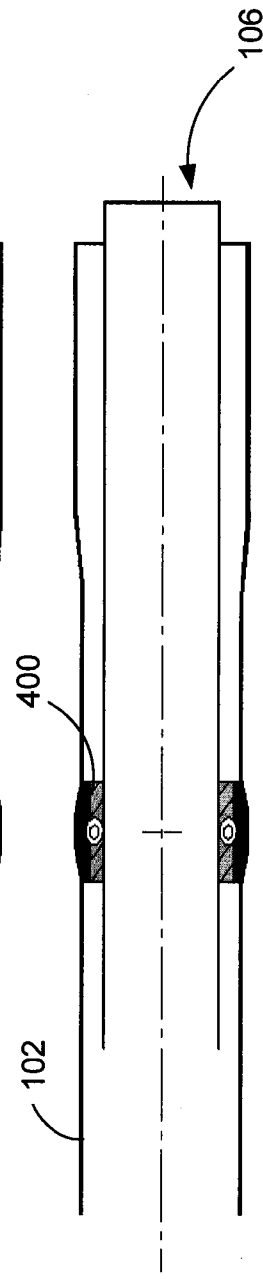

FIGURE 6D

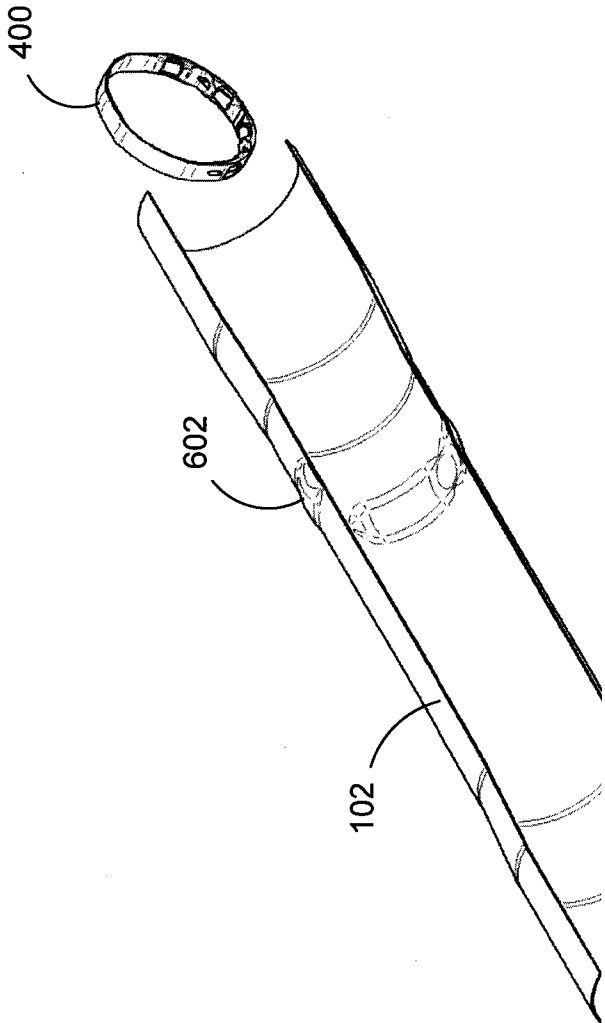

FIGURE 7A

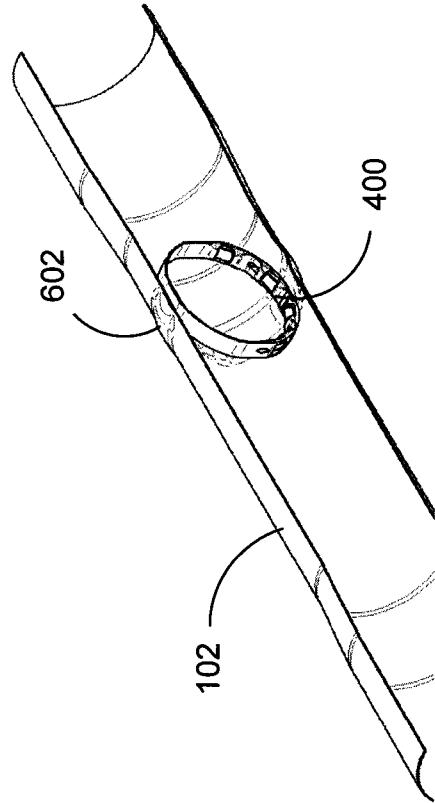

FIGURE 7B

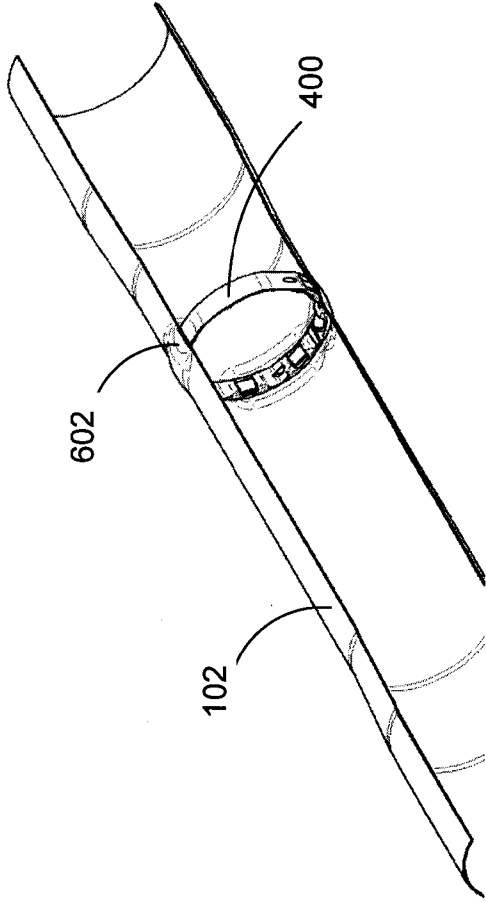

FIGURE 7C

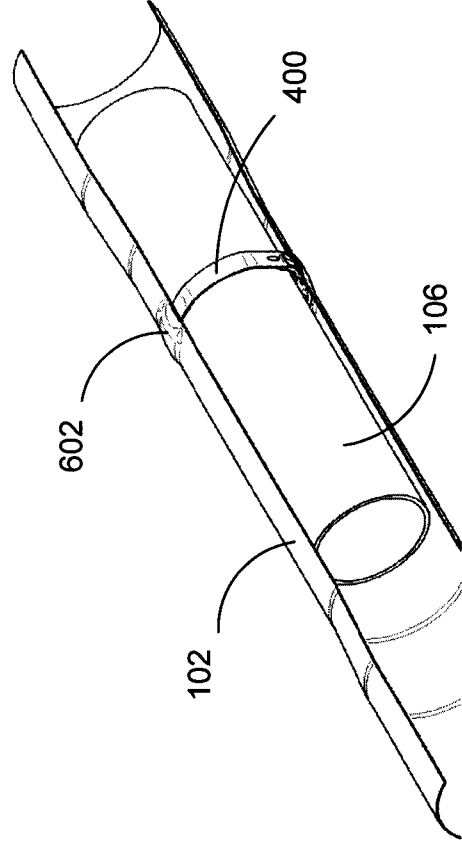

FIGURE 7D

