

C. J. VAN DEPOELE.

ELECTRIC RAILWAY CONDUIT WITH TUBULAR CONDUCTORS.

No. 435,263.

Patented Aug. 26, 1890.

Fig. 1.

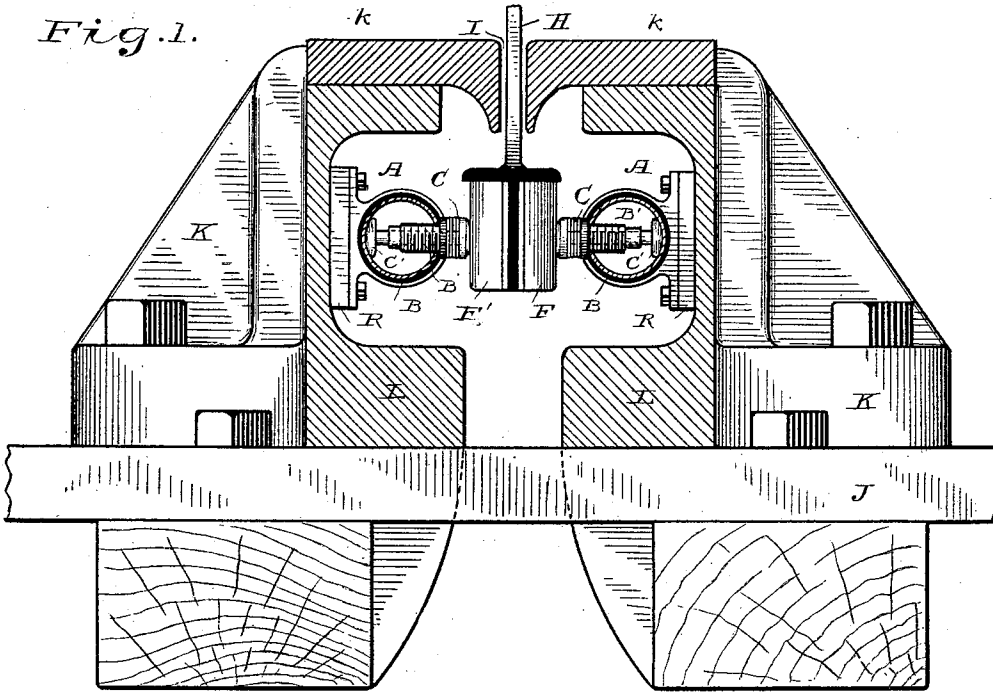
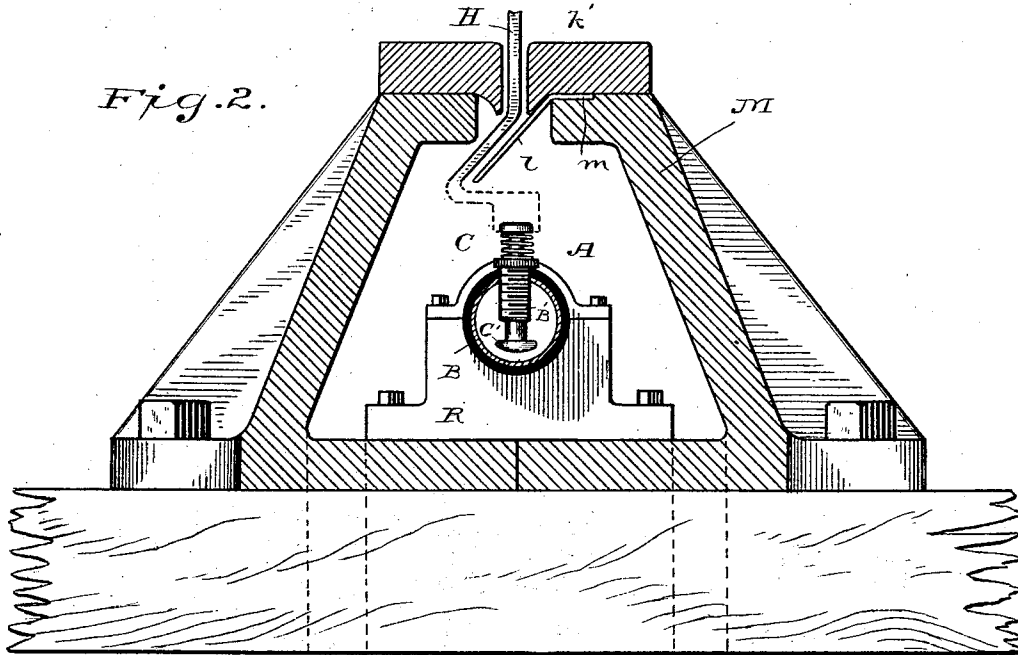

Fig. 2.



Witnesses

H. A. Lamb
 Stephen Jannus

Inventor

Charles J. Van Depoele

By his Attorney

Frankleud Jannus,

C. J. VAN DEPOELE.

ELECTRIC RAILWAY CONDUIT WITH TUBULAR CONDUCTORS.

No. 435,263.

Patented Aug. 26, 1890.

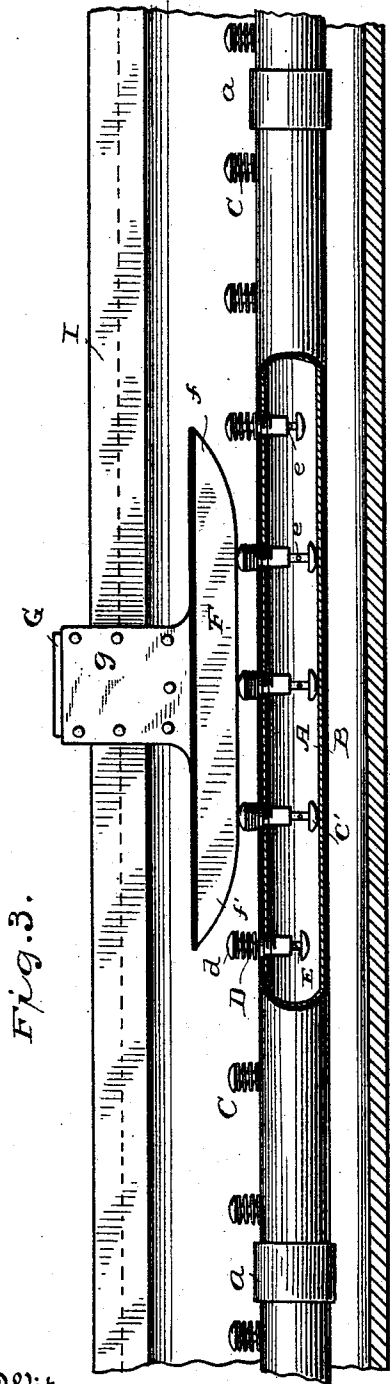

Fig. 3.

Fig. 5.

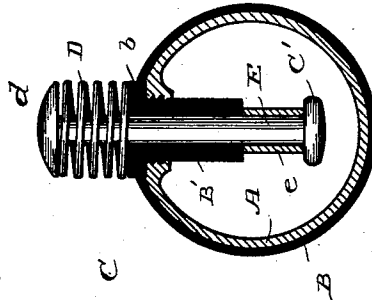
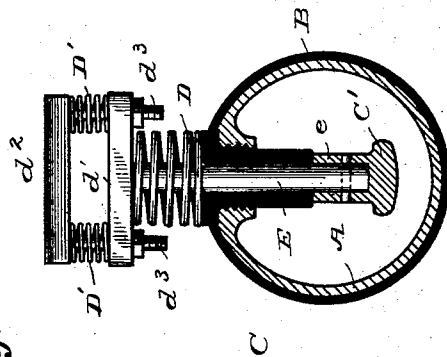

Fig. 4.



Witnesses

H. A. Lamb

Stephen James

Inventor

Charles J. Van Depoele

By his Attorney

Frankland James

C. J. VAN DEPOELE.

ELECTRIC RAILWAY CONDUIT WITH TUBULAR CONDUCTORS.

No. 435,263.

Patented Aug. 26, 1890.

Fig. 8.

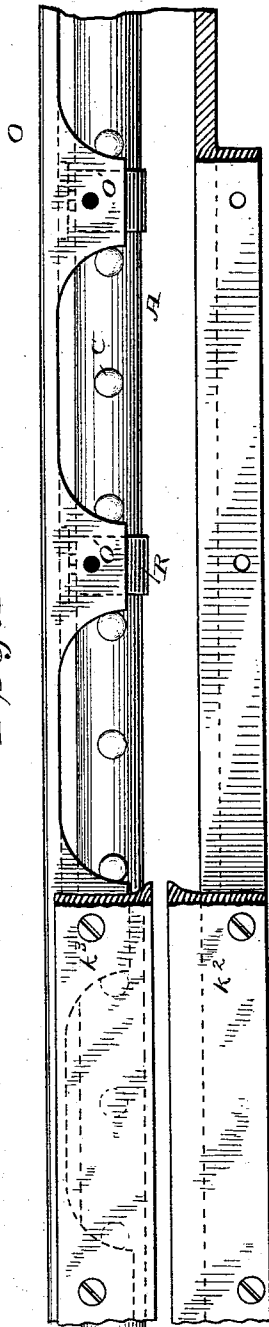

Fig. 7.

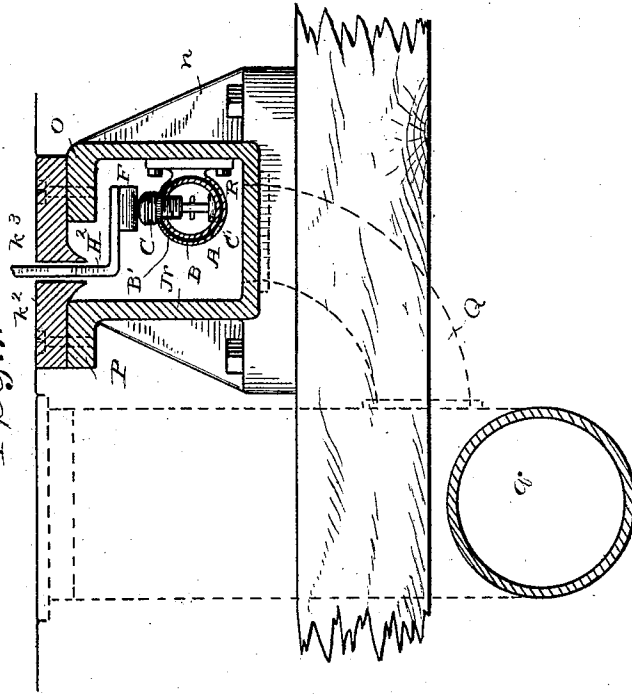
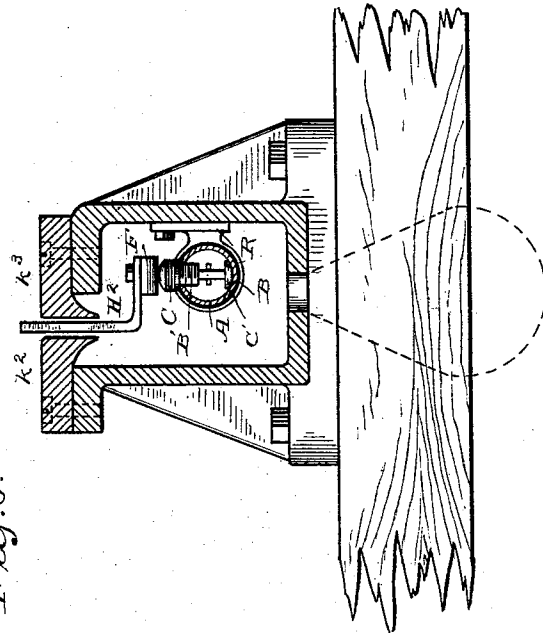

Fig. 6.



Witnesses

H. H. Lamb

Stephen James

Inventor

Charles J. VanDepoele

By his Attorney

Frankland James.

(No Model.)

4 Sheets—Sheet 4.

C. J. VAN DEPOELE.

ELECTRIC RAILWAY CONDUIT WITH TUBULAR CONDUCTORS.

No. 435,263.

Patented Aug. 26, 1890.

Fig. 9.

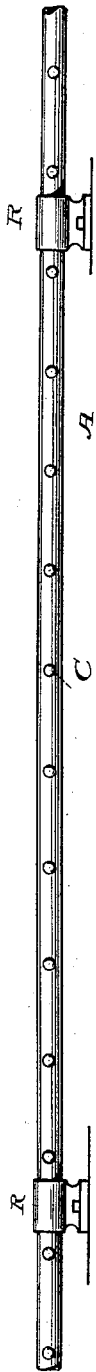

Fig. 10.

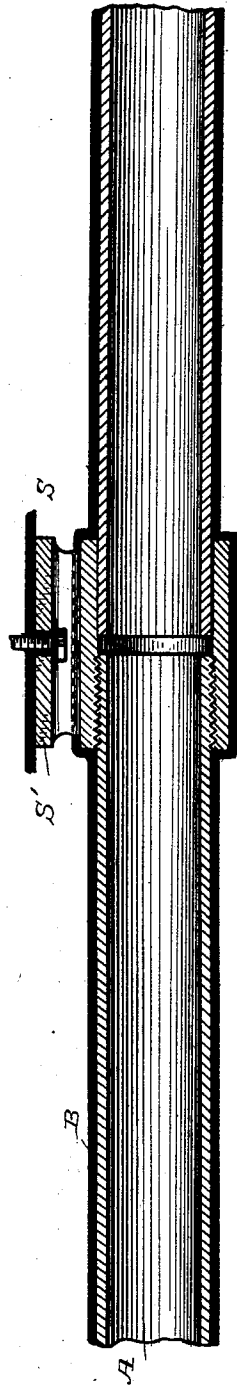
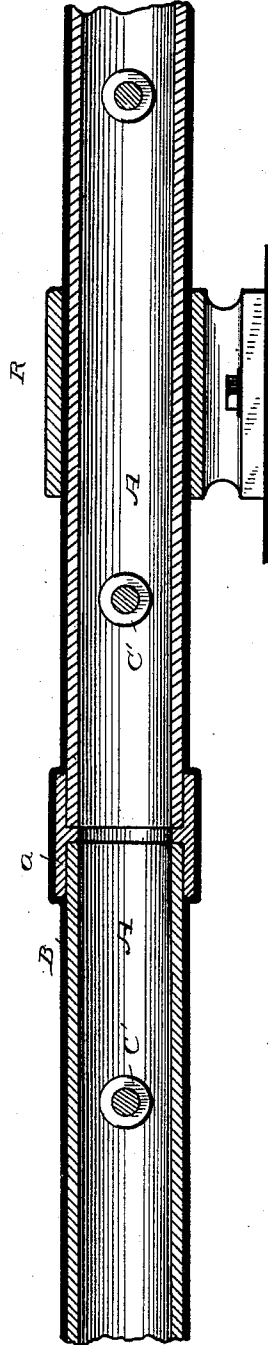

Fig. 11.



Witnesses,

H. A. Lamb,

Stephen Jarnes

Inventor

Charles J. VanDepoele

By his Attorney

Frankland Jarnes

UNITED STATES PATENT OFFICE.

CHARLES J. VAN DEPOELE, OF LYNN, MASSACHUSETTS.

ELECTRIC-RAILWAY CONDUIT WITH TUBULAR CONDUCTOR.

SPECIFICATION forming part of Letters Patent No. 435,263, dated August 26, 1890.

Application filed May 22, 1890. Serial No. 352,719. (No model.)

To all whom it may concern:

Be it known that I, CHARLES J. VAN DE-
POELE, a citizen of the United States, residing
at Lynn, in the county of Essex and State
of Massachusetts, have invented certain new
and useful Improvements in Electric-Railway
Conduits with Tubular Conductors, of which
the following is a description, reference being
had to the accompanying drawings, and to the
letters of reference marked thereon.

My invention relates to improvements in
electric railways, and more particularly to an
improved conduit for subsurface conductors,
the particular object of the invention being a
conduit within which a main supply con-
ductor or conductors can be completely in-
closed and effectually protected from any and
all exterior influences. With this object in
view I form each main supply-conductor as
a continuous metallic tube, which may be of
any desirable metal, although the cheapest
forms—such as wrought-iron gas-pipe—will
answer for this purpose. The tubular con-
ductor is to be well insulated upon its out-
side, as by a coating of a heavy bituminous
substance having high insulating properties,
together with a strong fabric. The tubular
conductor is carried upon insulating-supports
within the best-known form of slotted sub-
surface conduit, the conductor being then
doubly protected. The current is collected
from the interior surface of the tubular con-
ductor. This is accomplished by contact-
making devices in the form of metallic plun-
gers carried by insulating-sockets detachably
secured in the conductor and readily remov-
able for replacement or examination. The
contacts are separately constructed, and each
is provided with a small retracting-spring
contained within its casing, and they are all
arranged to be entirely independent and self-
acting. The current is collected by means
of a long shoe, which is carried by a thin
shank extending through the surface slot and
into mechanical as well as electrical connec-
tion with the vehicle, and the shoe is desir-
ably arranged to engage and press down a
plurality of contacts simultaneously—that is
to say, as one of the contacts is released by
the passage of the shoe one in advance is
pressed down and two or more are always
under pressure and in contact with the con-

ductor. With this arrangement the failure
of a few of the contacts would make very lit-
tle difference and would not be sufficient to
interfere with the operation of the line.

The details of construction of a form of my
apparatus are shown by way of illustration.

Figure 1 is a transverse end view, partly in
section, showing a double-conductor conduit
embodying the invention. Fig. 2 is a similar
view showing a conduit provided with a sin-
gle conductor. Fig. 3 is a longitudinal sec-
tional elevation of a portion of a single-con-
ductor conduit embodying the invention,
parts of the structure being broken away for
purposes of illustration. Figs. 4 and 5 are
enlarged detail views of the contact-makers.
Figs. 6 and 7 are sectional end views showing
details of the construction of the conduit.
Fig. 8 is a top plan view of a portion of the
conduit partly broken away and with parts
removed to show the interior arrangement.
Fig. 9 is a view in elevation showing a portion
of the tubular conductor removed from the
conduit. Figs. 10 and 11 are enlarged detail
views showing means for sustaining the tubu-
lar conductor in working position.

In the drawings, A is the tubular conductor,
which may be composed of any suitable
metal, that having the highest conductivity
being of course the very best for the pur-
pose. By the disposition of the necessary
parts I am, however, enabled to employ
cheaper material with good results, and find
that according to the present invention I can
construct the main supply conductor or con-
ductors of the very cheapest and the most
available material—for instance, galvanized
wrought-iron gas-pipe. This is due to the
fact that I prefer to use a tubular conductor
of considerable size and to make the run-
ning contact upon the interior thereof. Hav-
ing considerable cross-section, the mass of
the metal forming the pipe-conductor will be
so great that even though of inferior con-
ductivity its resistance will be low enough
to economically convey the currents usually
employed on electric-railway working-con-
ductors, and enable me therefore to use the
simplest, most durable, and at the same time
cheapest and most available form of inclosed
conductor yet proposed. The tubular met-
allic conductor A is formed in sections of

any suitable or convenient length, which may be united by welding, lapping, or the usual collars *a*, into which the ends of the sections to be joined are fitted. The collars *a* may be screw-threaded at one end, but should be plain at the other, so that one end of the pipe may be fitted thereto without screw-connections, in order to allow of movement therein to compensate for expansion and contraction. The continuous tubular conductor is insulated upon its exterior throughout its whole length, the insulation extending over the couplings, so as to prevent the access of moisture at any point. The insulation *B* may be applied in any desired manner; but for many purposes a smooth wrapping of heavy fabric thoroughly coated with insoluble insulating material will answer all purposes, although there are many known compositions of matter which may be applied to the exterior of the tubular conductor to form a very efficient exterior insulation therefor. The current is collected from the interior of the tubular conductor by means of a series of contact devices secured in and extending through the walls thereof. These contacts, while permanently in position, are all normally out of contact and only rendered active upon the passage of the current-collecting device moving with the vehicle.

A series of holes are formed along the tubular conductor and at regular intervals, and said holes may be at any desired distance. As here indicated they are about a foot apart, and in each of these holes is secured a spring-contact device *C*. Each contact device comprises an insulating-socket *B'*, which is screw-threaded to engage corresponding screw-threads in the openings in the tubular conductor and provided with a suitable shoulder *b*, so that it may be screwed down into perfectly tight contact with the exterior of the conductor. The socket *B'* extends into the tubular conductor and carries a contact *C'* at its lower extremity, which contact may be of carbon, if desired. The contact *C'* is secured to the lower end of a stem *E*, which extends upward through the socket *B'* and is provided at its outer end with a metallic head *d*. Between the head *d* and the shoulder *b* of the socket is placed a spring *D*, which normally sustains the stem, head, and contact, so that the contact is well clear of the interior surface of the conductor. A collar or pin *e*, connected with the lower part of the stem *E*, limits the action of the spring *D*, and when the contact-makers are similarly constructed the heads *d* will be normally in substantially the same horizontal plane. The conductor being sustained in substantially similar relation to a railway-track, it follows that a vehicle traveling upon the said track and provided with a current-collecting device arranged to depress the heads *d* successively will in its travel be continuously supplied with current conveyed from the interior of the tubular conductor through the con-

tacts *C'*, stems *E*, heads *d*, and the traveling collector. A form of collector is indicated in Fig. 3, the same comprising an extended metal shoe *F*, having upwardly-sloped extremities *f*. As shown, the collector *F* is of a length sufficient to engage three of the contacts, and in its forward movement it will always depress one contact in advance before leaving the rearmost one, thereby preventing breaking of the circuit and consequent wear on the parts from sparking, and there will, moreover, always be enough of the contacts in action to carry any desired amount of current. Obviously, the collector can be made longer or shorter, as desired. The contact-piece *F* of the collector should be well protected by exterior insulation, and the upwardly-extending portion thereof *G* should be protected by insulation and also by exterior wearing-plates *g* at that part where it is liable to be brought in contact with the adjacent structure.

A special feature of the invention consists in the facility with which a damaged contact-maker can be replaced, it being only necessary to unscrew the socket *B'* and substitute another, since the entire mechanism of the said contact-makers is self-contained. It may sometimes happen that through irregularities in the conductor a sufficient number of the contacts may fail to be properly depressed by the traveling collector, and under such circumstances greater range of spring will be desirable, when the construction indicated in Fig. 4 may be employed. In said figure the head *d* is replaced by a cross-bar *d'*, upon which is spring-supported a head *d²*. Springs *D'* connect the head *d²* with its immediate support *d'*, and adjustable bolts *d³* pass through the cross-bars *d'* for adjusting the tension of the secondary springs *D'*. The springs *D'* should preponderate in power, so that the springs *D* will be depressed and the contact be brought into engagement with the conductor before the other set of springs yields, as may be necessary to permit the passage of the collector.

Various forms of subsurface conduits may be employed in connection with my improved conductor, several constructions of which will be referred to.

Fig. 1 shows a double-conductor conduit having one of my improved conductors arranged on each side, so that the contacts *C* form two parallel horizontal lines, between which moves a double collector comprising vertical shoes *FF'*, thoroughly insulated from each other and provided with separate insulated extensions conveyed upward through the blade *H*, which passes through the surface slot *I* into connection with the moving vehicle. The conduit itself comprises a metallic base-piece *J*, upon which are secured at suitable intervals side brackets *K*. To the side brackets are secured hollow U-shaped side pieces *L*, which are set up edgewise upon the base *J* and secured thereto. In the hol-

lows of the side pieces are located the conductors A, being sustained in position by proper insulated supports R. The road-bars or capping-plates k k are sustained upon the upper edges of the side pieces L, from which of course they may readily be removed to permit access to the conduit. The side pieces L do not meet either above or below. Consequently there exists between them a continuous open-drainage slot at their lower part, through which any matter entering the surface slot will fall and in most cases without lodging upon the contacts C.

Fig. 2 shows a slightly-different construction, resembling the exterior structures shown in Fig. 1 of my patent, No. 408,639, dated August 6, 1889, but provided in addition with a deflecting-strip l , which is formed of a thin continuous piece of metal, the upper edge of which is secured between the edge m of the side wall M of the conduit and the capping-plate k' . In this form the conductor is arranged centrally within the conduit with its contact C in vertical position, and the blade H' is curved so as to extend over and reach under the deflecting-strip l .

A very simple and desirable form of conduit is indicated in Figs. 6, 7, and 8, in which continuously-joined sections of metal trough N are sustained within yokes n , carried upon the cross-ties of the roadway. With this form the conduit is preferably about square, and has one upper edge O turned inward and its opposite edge P turned outward. Furthermore, the inturned edge O is cut away as much as possible—that is, formed with long scallops between the points O', at which the conductor is supported. The conductor is arranged at one side of the conduit under the edge O, so that, as indicated in Fig. 8, when the road-bars are removed free access can be had to almost every part of the conductor, and the conductor can be placed or removed through the opening so made. In order to afford equal support to the road-bars k^2 k^3 , they are so placed that the slot is formed at one side of the conduit, and consequently the blade H² is curved inwardly to bring the collector F upon the contacts C. The conduit may be drained at suitable points by connections Q, with a sewer q , the connections being indicated in dotted lines. Suitable short tubular supports R are provided for the conductor, the said supports fitting over the exterior insulation thereof and being suitably attached to the walls of the conduit. The said supports may be of hard strong insulating material or they may be of metal and be insulated from the conduit at the point of attachment. The conductor may be either slipped through the support in sections before being united or the said support may be divisible and joined after the conductors are in place. Where the sections are short, the supports themselves may constitute the couplings, and such a form is indicated at S, Fig. 10. The support S is formed with

a part or short bracket S', for attachment to the side wall of the conduit, and is provided with insulations at its point of support. The tubular part of the support S is formed as a slip-joint at one end and is screw-threaded at the other, thereby affording an efficient support for the ends of the conductor and at the same time allowing for expansion and contraction. Where more than one support is required for each section of conductor, as where the sections are made of considerable length, tubular and preferably divisible supports are provided between and in addition to the end supports. The supports will usually be of about the same thickness as the ordinary couplings, and will therefore interpose no obstacle to the free travel of the collector, since they will all be below the plane of compression of the contacts.

The inner edges of the road-bars are arranged in every instance clear of the contacts, and therefore extraneous matter entering the slot will usually pass clear of the conductor, and the conduits, being provided with drainage-openings at their lower part, will usually be kept clear of foreign matter without difficulty.

In the forms shown in Figs. 1, 6, and 7 brushes might readily be run in the conduit for the purpose of cleaning the same. Furthermore, it is believed that the conductor as here described is most completely protected from all extraneous matter, as when all the parts are in good condition it will be practically air-tight. The contacts, as well as the material of the conductor itself, should be of non-corrosive material; but notwithstanding this it may be found desirable to occasionally force dry air through the tubular conductor, which may readily be done by connecting an air-pump to one end of the conductor, which may be found advantageous under some circumstances, as pointed out in my patent, No. 404,325, dated May 28, 1889.

The hereinbefore-described hollow conductor insulated upon its exterior and carrying contact-makers extending through its walls I believe to be entirely novel, and as such claim the same, broadly, and it is here particularly pointed out that my improved conductor is especially applicable to existing conduits in which electric conductors have failed by grounding or otherwise, or in which the cable system has been employed. The supporting devices can of course be readily modified to suit the interior construction of my conduit.

It will be obvious that various minor changes and modifications may be made in the details of the herein-described invention without departing from the spirit or nature thereof, and I therefore do not limit myself to precisely what is herein shown and described by way of necessary illustration.

Having described my invention, what I claim, and desire to secure by Letters Patent, is—

1. A tubular conductor and fixed contact devices extending from the exterior to the interior thereof, substantially as described.
2. A tubular conductor inclosed in insulating material and fixed contact-making devices extending from the exterior to the interior thereof, substantially as described.
3. A tubular conductor having an exterior insulating-envelope and fixed contact making devices extending through and sustained therein, substantially as described.
4. A tubular conductor permanently inclosed within an insulating-envelope and having contact-making devices extending through both the insulation and the conductor to make contact with the interior of the conductor and removably sustained in the wall thereof, substantially as described.
5. The combination of a tubular conductor inclosed within an insulating-envelope, a contact device comprising an insulating-support extending through the wall of the conductor, a movable contact, and a spring for retracting the same.
6. The combination of a tubular conductor inclosed within an insulating-envelope, a contact device comprising an insulating-support extending through the wall of the conductor, a movable contact, a spring for retracting the same, and a traveling current-collector arranged to move the contact into engagement with the interior of the conductor.
7. A continuous tubular conductor comprising tubular sections, metallic couplings uniting the ends of the sections, an exterior insulating-envelope inclosing the sections and couplings, and a series of contact-making devices carried by and extending from the exterior to the interior of the conductor, substantially as described.
8. The combination, with a slotted subsurface conduit, of a hollow conductor or conductors sustained within said conduit and provided with an exterior insulating-envelope and contact devices extending from the exterior to the interior thereof, and a traveling collecting device or devices extending through the slot of the conduit into engagement with the contact devices upon the conductor or conductors, substantially as described.
9. The combination, with a slotted subsurface conduit, of a hollow conductor or conductors formed of tubular sections united by tubular couplings provided with brackets for attachment to the wall or walls of the conduit sustained within said conduit and provided with an exterior insulating-envelope and contact devices extending from the exterior to the interior thereof, and a traveling collecting device or devices extending through the slot into engagement with the contact devices upon the conductor or conductors, substantially as described.
10. The combination, with a tubular conductor, an inclosing insulating-envelope therefor, and suitable supports, of an exterior casing or conduit composed of a metallic trough, against one side of the interior of which the conductor-supports are attached, said conduit having an inwardly-turned edge extending over the conductor and road-bars arranged to form a surface slot at or near one side of the conduit, and a collecting device extending through the slot of the conduit and curved into line with the contact devices upon the conductor, substantially as described.
11. A subsurface conduit comprising a metallic trough having one edge turned inwardly and one outwardly, road-bars sustained upon said edges to form a surface slot adjacent to one side of the conduit, said inwardly-turned edge being indented to give greater access to the conduit when the road-bar is removed, and a suitable conductor sustained within the conduit under the inwardly-turned edge, substantially as described.

In testimony whereof I affix my signature in presence of two witnesses.

CHARLES J. VAN DEPOELE.

Witnesses:

HENRY A. LAND,
WM. D. POOL.