

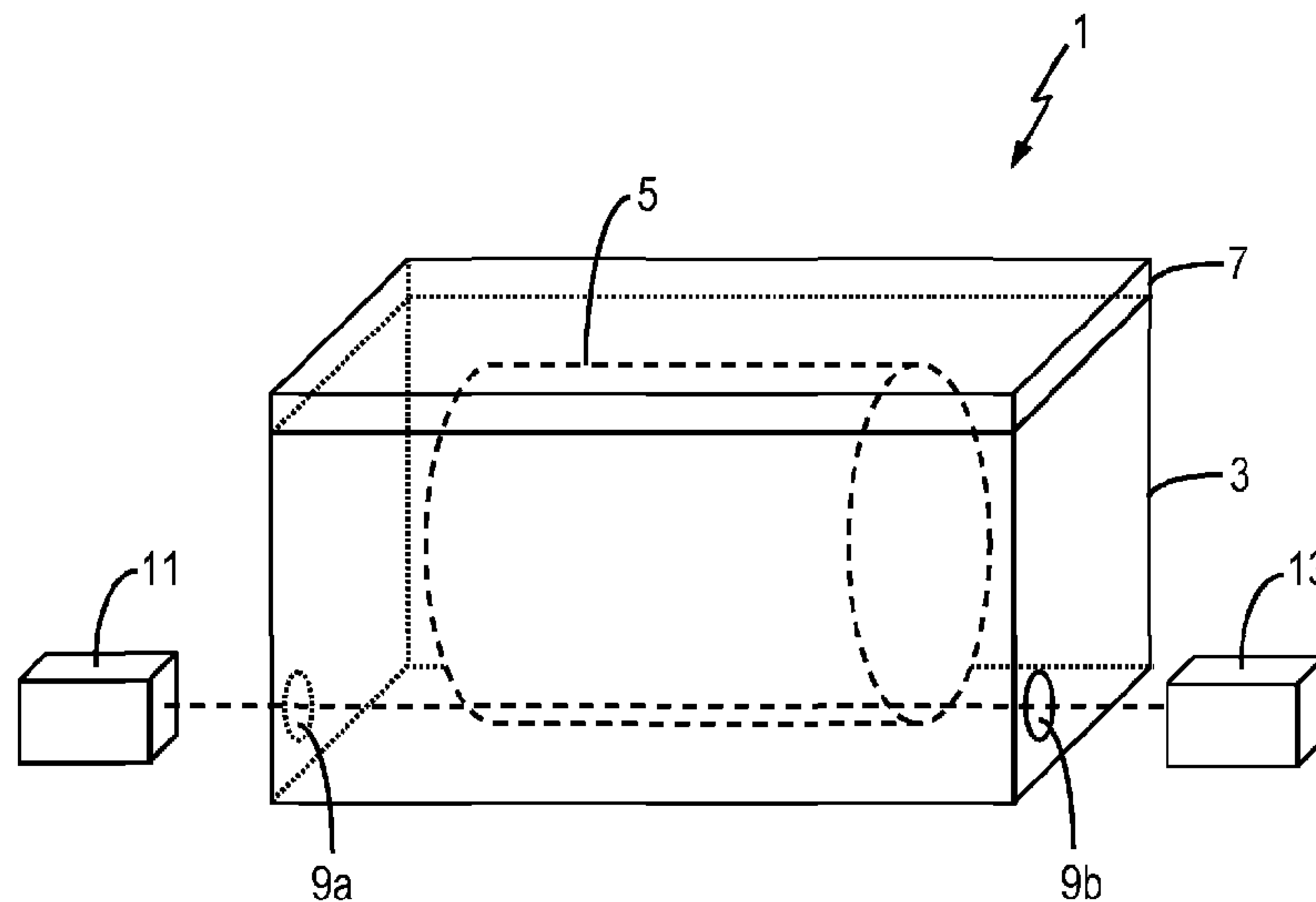

(86) Date de dépôt PCT/PCT Filing Date: 2012/07/10
(87) Date publication PCT/PCT Publication Date: 2013/01/17
(45) Date de délivrance/Issue Date: 2019/06/18
(85) Entrée phase nationale/National Entry: 2014/01/08
(86) N° demande PCT/PCT Application No.: GB 2012/051621
(87) N° publication PCT/PCT Publication No.: 2013/008003
(30) Priorité/Priority: 2011/07/11 (GB1111837.9)

(51) Cl.Int./Int.Cl. *C12H 1/22* (2006.01),
G01N 21/35 (2014.01), *G01N 33/14* (2006.01)
(72) Inventeurs/Inventors:
MALCOLM, GRAEME PETER ALEXANDER, GB;
MAKER, GARETH THOMAS, GB;
ROBERTSON, GORDON, GB
(73) Propriétaire/Owner:
M SQUARED LASERS LIMITED, GB
(74) Agent: MERIZZI RAMSBOTTOM & FORSTER

(54) Titre : APPAREIL ET PROCEDES DE MATURATION
(54) Title: MATURATION APPARATUS AND METHODS



(57) **Abrégé/Abstract:**

The invention provides an apparatus and a method that reduces fluid loss from a cask during a maturation process by sealably enclosing the cask in a vessel that provides an expansion volume to receive fluid vapour from the cask, a monitoring system and a method that monitors fluid loss from a cask during a maturation process using a light source and a detector to determine the presence of fluid vapour in the vicinity of the cask, a corresponding system for controlling a maturation process in which environmental conditions are controlled, and a cask leak testing system and method making use of the above.

(12) INTERNATIONAL APPLICATION PUBLISHED UNDER THE PATENT COOPERATION TREATY (PCT)

(19) World Intellectual Property
Organization
International Bureau(10) International Publication Number
WO 2013/008003 A1(43) International Publication Date
17 January 2013 (17.01.2013)

(51) International Patent Classification:

C12H 1/22 (2006.01) G01N 33/14 (2006.01)
G01N 21/35 (2006.01)

(21) International Application Number:

PCT/GB2012/051621

(22) International Filing Date:

10 July 2012 (10.07.2012)

(25) Filing Language:

English

(26) Publication Language:

English

(30) Priority Data:

1111837.9 11 July 2011 (11.07.2011) GB

(71) Applicant (for all designated States except US): **M SQUARED LASERS LIMITED** [—/GB]; Venture Building, 1 Kelvin Campus, West of Scotland Science Park, Maryhill Road, Glasgow Strathclyde G20 0SP (GB).

(72) Inventors; and

(75) Inventors/Applicants (for US only): **MALCOLM, Graeme Peter Alexander** [GB/GB]; M Squared Lasers, Venture Building, 1 Kelvin Campus, West of Scotland Science Park, Maryhill Road Glasgow Strathclyde G20 0SP (GB). **MAKER, Gareth Thomas** [GB/GB]; M Squared Lasers Limited, Venture Building, 1 Kelvin Campus, West of Scotland Science Park, Maryhill Road Glasgow Strathclyde G20 0SP (GB). **ROBERTSON, Gordon** [GB/GB]; M Squared Lasers Limited, Venture Building, 1 Kelvin

Campus, West of Scotland Science Park, Maryhill Road Glasgow Strathclyde G20 0SP (GB).

(74) Agent: **LINCOLN IP**; 9 Victoria Street, Aberdeen, Aberdeenshire AB10 1XB (GB).

(81) Designated States (unless otherwise indicated, for every kind of national protection available): AE, AG, AL, AM, AO, AT, AU, AZ, BA, BB, BG, BH, BR, BW, BY, BZ, CA, CH, CL, CN, CO, CR, CU, CZ, DE, DK, DM, DO, DZ, EC, EE, EG, ES, FI, GB, GD, GE, GH, GM, GT, HN, HR, HU, ID, IL, IN, IS, JP, KE, KG, KM, KN, KP, KR, KZ, LA, LC, LK, LR, LS, LT, LU, LY, MA, MD, ME, MG, MK, MN, MW, MX, MY, MZ, NA, NG, NI, NO, NZ, OM, PE, PG, PH, PL, PT, QA, RO, RS, RU, RW, SC, SD, SE, SG, SK, SL, SM, ST, SV, SY, TH, TJ, TM, TN, TR, TT, TZ, UA, UG, US, UZ, VC, VN, ZA, ZM, ZW.

(84) Designated States (unless otherwise indicated, for every kind of regional protection available): ARIPO (BW, GH, GM, KE, LR, LS, MW, MZ, NA, RW, SD, SL, SZ, TZ, UG, ZM, ZW), Eurasian (AM, AZ, BY, KG, KZ, RU, TJ, TM), European (AL, AT, BE, BG, CH, CY, CZ, DE, DK, EE, ES, FI, FR, GB, GR, HR, HU, IE, IS, IT, LT, LU, LV, MC, MK, MT, NL, NO, PL, PT, RO, RS, SE, SI, SK, SM, TR), OAPI (BF, BJ, CF, CG, CI, CM, GA, GN, GQ, GW, ML, MR, NE, SN, TD, TG).

Published:

— with international search report (Art. 21(3))

[Continued on next page]

(54) Title: MATURATION APPARATUS AND METHODS

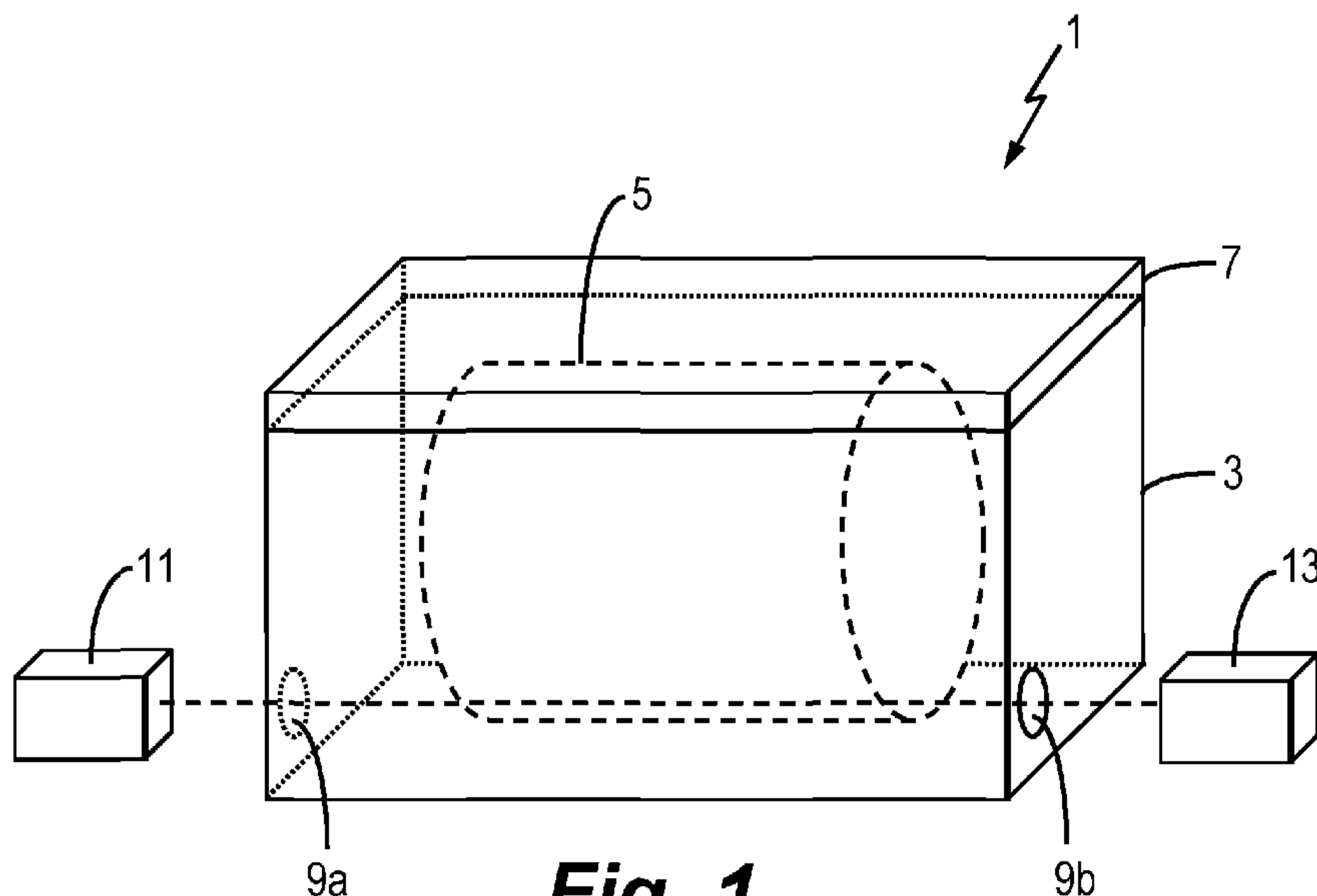
**Fig. 1**

(57) Abstract: The invention provides an apparatus and a method that reduces fluid loss from a cask during a maturation process by sealably enclosing the cask in a vessel that provides an expansion volume to receive fluid vapour from the cask, a monitoring system and a method that monitors fluid loss from a cask during a maturation process using a light source and a detector to determine the presence of fluid vapour in the vicinity of the cask, a corresponding system for controlling a maturation process in which environmental conditions are controlled, and a cask leak testing system and method making use of the above.

WO 2013/008003 A1

WO 2013/008003 A1 

- *before the expiration of the time limit for amending the claims and to be republished in the event of receipt of amendments (Rule 48.2(h))*

1 Maturation apparatus and methods

2

3 The present invention relates to apparatus and methods for use in maturation processes,
4 and in particular apparatus and methods for reducing fluid loss from a cask during a
5 maturation process, and apparatus and methods for controlling and for monitoring a
6 maturation process. A particular embodiment provides a vessel to sealably enclose the
7 cask and provide an expansion volume to receive fluid vapour from the cask.

8

9 Background to the invention

10

11 Scotch malt whisky production involves several stages, the most important of which is
12 arguably the maturation process by which new-make whisky is matured for several years
13 in wooden casks.

14

15 Whisky is typically ~60% water, ~40% ethanol (and ~0.1% other constituents), when it is
16 casked, but during the maturation process (which typically takes ten to twenty years) a
17 proportion of the fluid volume in the cask is lost to the atmosphere. This is affectionately
18 referred to in the trade as the “angels’ share”.

19

1 The angels' share is, in Scotland, typically around 2% volume per annum. Elsewhere in
2 the world the loss can be as high as 5% per annum. Some whisky producers may have
3 tens of millions of whisky casks undergoing maturation at any one time so these losses are
4 clearly significant.

5

6 In fact, the angels' share is reported to cost on the order of 10-15% of the production cost.
7 It is therefore desirable to reduce or prevent this lost volume of product. Experiments have
8 been conducted in which casks have been shrink-wrapped; however while fluid loss is
9 eliminated (or significantly reduced) there is a corresponding elimination (or significant
10 reduction) in air ingress which is believed to negatively affect the maturation process and
11 hence the taste of the final product.

12

13 Wines, cognacs, armagnacs, sherries, ports, whiskeys (e.g. Bourbon) and beers may also
14 be matured in barrels (as may balsamic vinegar), and the angels' share loss problem is
15 also known to affect these maturation processes (to lesser or greater extents). This is
16 therefore a wide reaching problem, and a solution that at least partially solves the problem
17 will provide major economic benefits.

18

19 In view of the foregoing, it is an object of at least one embodiment of an aspect of the
20 present invention to provide an apparatus that can reduce or prevent fluid loss during a
21 maturation process, and a corresponding method.

22

23 It is also an object of at least one embodiment of an aspect of the present invention to
24 provide a system for monitoring and/or controlling a maturation process, and a
25 corresponding method.

26

1 Summary of the invention

2

3 According to a first aspect of the invention, there is provided an apparatus to reduce fluid
4 loss from a cask during a maturation process, the apparatus comprising a vessel to
5 sealably enclose the cask and provide an expansion volume to receive fluid vapour from
6 the cask.

7

8 In conventional maturation processes, whisky casks (for example) leak ethanol vapour to
9 the surrounding environment. By sealably enclosing the whisky cask and providing an
10 expansion volume, ethanol vapour is initially able to leave the cask until the partial
11 pressure of ethanol vapour (or other fluid lost from the cask) within the vessel reaches an
12 equilibrium value at which there will be no further leakage.

13

14 Preferably, the apparatus further comprises a monitoring system arranged to monitor the
15 presence of fluid vapour within the vessel.

16

17 The monitoring system permits monitoring of the leak rate as a function of time.

18

19 Preferably, the monitoring system comprises a light source and a detector, the detector
20 arranged to receive light from the light source and the monitoring system configured to
21 determine a relative transmission of the light through the vessel.

22

23 Preferably, the apparatus comprises at least one aperture in a wall of the vessel, the light
24 source and detector arranged on opposite sides of the aperture. Preferably, the apparatus
25 comprises two apertures located in walls of the vessel and defining an optical path through
26 the vessel intersecting the light source and the detector. Alternatively, the apparatus
27 further comprises a mirror arranged to receive and reflect light from the light source to the
28 detector via a same aperture. Preferably, the at least one aperture comprises a window.
29 For example, the window may comprise calcium fluoride (CaF_2).

30

31 Preferably, the light source comprises a laser source. Most preferably, the light source
32 comprises an infrared laser source. Optionally, the light source comprises an optical
33 parametric oscillator mid-infrared source. Alternatively, the light source comprises a
34 quantum cascade laser source. The light source may be tuned to an absorption line or

1 absorption band of ethanol. Alternatively, or additionally, the monitoring system comprises
2 an active infrared hyperspectral imaging system.

3

4 Advantageously, the vessel comprises a lid. The lid and/or main body of the vessel may
5 be provided with a rubber gasket or O-ring to provide a seal there between. Preferably,
6 the vessel is rectangular. Alternatively, the vessel is cylindrical or cask-shaped.

7

8 Optionally, the vessel is sized to receive a plurality of casks. Alternatively, or additionally,
9 the vessel is in fluid communication with one or more like vessels with or without
10 respective monitoring systems.

11

12 According to a second aspect of the invention, there is provided a method of reducing fluid
13 loss from a cask during a maturation process, the method comprising sealing the cask
14 within a vessel having an expansion volume, and receiving fluid vapour from the cask in
15 the expansion volume of the vessel.

16

17 Preferably, the method further comprises monitoring the presence of ethanol within the
18 sealed vessel. Most preferably, the method further comprises monitoring the presence of
19 water vapour within the sealed vessel.

20

21 Preferably, the method comprises obtaining a background measurement of the presence
22 of ethanol within the sealed vessel. Preferably, the method comprises recording the
23 presence of ethanol within the sealed vessel as a function of time.

24

25 Embodiments of the second aspect of the invention may include one or more features
26 corresponding to features of the first aspect of the invention or its embodiments, or vice
27 versa.

28

29 According to a third aspect of the invention there is provided a monitoring system to
30 monitor fluid loss from a cask during a maturation process, the monitoring system
31 comprising a light source and a detector, the detector arranged to receive light from the
32 light source and the monitoring system arranged to determine the presence of fluid vapour
33 in the vicinity of the cask.

34

1 Preferably, the light source comprises a laser source. Preferably, the light source
2 comprises an optical parametric oscillator mid-infrared source. Alternatively, the light
3 source comprises a quantum cascade laser source. The light source may be tuned to an
4 absorption line or absorption band of ethanol.

5

6 Embodiments of the third aspect of the invention may include one or more features
7 corresponding to features of the first or second aspects of the invention or its
8 embodiments, or vice versa.

9

10 According to a fourth aspect there is provided a method of monitoring fluid loss from a
11 cask during a maturation process, the method comprising emitting light from a light source,
12 receiving light from the light source at a detector, and determining a relative transmission
13 of the light in the vicinity of the cask.

14

15 Preferably, the method comprises locating one or both of the light source and detector
16 proximal to the cask.

17

18 Embodiments of the fourth aspect of the invention may include one or more features
19 corresponding to features of the first, second or third aspects of the invention or its
20 embodiments, or vice versa.

21

22 According to a fifth aspect of the invention, there is provided a system for controlling a
23 maturation process, the system comprising the apparatus of the first aspect and a control
24 system configured to control environmental conditions within the sealed vessel.

25

26 Preferably, the vessel is sized to provide sufficient atmospheric oxygen for at least a
27 portion of the maturation process. Alternatively, or additionally, the vessel is sized to
28 provide sufficient water vapour for at least a portion of the maturation process.

29

30 Preferably, the system comprises at least one pump operable to control an ambient
31 pressure within the vessel. Optionally, the pump is operable to maintain a target ambient
32 pressure within the vessel.

33

34 Optionally, the system comprises one or more gas sources in fluid communication with the
35 vessel, operable to control the presence of one or more gases within the vessel.

1

2 Preferably, the system further comprises one or more heating and/or cooling devices
3 configured to control a temperature of the vessel.

4

5 Embodiments of the fifth aspect of the invention may include one or more features
6 corresponding to features of the first to fourth aspects of the invention or its embodiments,
7 or vice versa.

8

9 According to a sixth aspect of the invention, there is provided a method of controlling a
10 cask maturation process, comprising sealing the cask within a vessel, and controlling
11 environmental conditions within the sealed vessel.

12

13 Preferably, the method comprises controlling the temperature within the vessel.

14

15 Preferably, the method comprises controlling the atmospheric pressure within the vessel.

16

17 Optionally, the method comprises adding one or more gases to the vessel.

18

19 Advantageously, the method comprises adding one or more substances selected to
20 simulate a geographic location during maturation.

21

22 Advantageously, the method comprises maintaining a positive atmospheric pressure within
23 the vessel. Additionally, or alternatively, the method comprises controlling a partial
24 pressure of water vapour within the vessel to control the relative loss of water versus
25 ethanol from the cask.

26

27 Optionally, the method comprises periodically purging the vessel. This permits further gas
28 exchange between the cask and the expansion volume in the vessel, most preferably after
29 the equilibrium condition is reached.

30

31 Embodiments of the sixth aspect of the invention may include one or more features
32 corresponding to features of any of the first to fifth aspects of the invention or its
33 embodiments, or vice versa.

34

1 According to a seventh aspect of the invention, there is provided a cask leak testing
2 system, comprising the apparatus of the first aspect, the system of the third aspect, or the
3 system of the fifth aspect.

4

5 Optionally, the system comprises imaging means configured to obtain one or more images
6 of the cask to identify the location and size of one or more leaks in the cask. Optionally,
7 the imaging means comprises an active infrared hyperspectral imaging system.

8

9 Embodiments of the seventh aspect of the invention may include one or more features
10 corresponding to features of any of the first to sixth aspects of the invention or its
11 embodiments, or vice versa.

12

13 According to an eighth aspect of the invention, there is provided a method of testing a cask
14 for leaks, comprising sealing the cask within a vessel of the first aspect and employing a
15 monitoring system of the third aspect.

16

17 Preferably, the method comprises filling the cask with a test gas, and detecting the
18 presence of the test gas within the expansion volume of the vessel using the monitoring
19 system.

20

21 Embodiments of the eighth aspect of the invention may include one or more features
22 corresponding to features of any of the first to seventh aspects of the invention or its
23 embodiments, or vice versa.

24

1 Brief description of the drawings

2

3 There will now be described, by way of example only, various embodiments of the
4 invention with reference to the drawings, of which:

5

6 Figure 1 illustrates in schematic form an apparatus to monitor and control whisky
7 maturation process in accordance with an aspect of the present invention; and

8

9 Figure 2 is a graph of relative transmission of a light beam directed through the apparatus
10 illustrated in Figure 1 versus time, during the initial stages of a maturation process, in
11 accordance with an aspect of the present invention.

1 Detailed description of preferred embodiments

2

3 The following example is described in the context of the maturation of whisky within a
4 whisky cask, however it will be understood that the invention finds utility in other
5 maturation processes; for example of wine, cognac, armagnac, sherry, port, whiskey (e.g.
6 Bourbon), beer and balsamic vinegar. Furthermore, while wooden casks are typically
7 employed it is understood that casks made from other materials (such as plastics or
8 metals as increasingly used in wine maturation) shall not fall outside the scope of
9 protection set out herein.

10

11 Figure 1 illustrates an apparatus 1 for monitoring and controlling the whisky maturation
12 process, comprising a vessel 3 to house a whisky cask 5. The vessel 3 is rectangular box,
13 in this embodiment made of aluminium, and comprises a lid 7 to provide access to the
14 vessel. The lid 7 is held in place using screws and has a rubber gasket (not shown) such
15 that when the lid 7 is screwed down the vessel 3 is sealed. The vessel provides an
16 expansion volume (i.e. the internal volume not occupied by the cask 5) into which vapour
17 (e.g. ethanol vapour) from the cask may expand. As will be demonstrated below,
18 experimental results show that this prevents further fluid loss from the cask once an
19 equilibrium condition is reached.

20

21 Two apertures 9a, 9b are provided at opposing ends of the vessel, defining an optical path
22 through the vessel. The apertures are sealed by way of calcium fluoride (CaF_2) windows
23 affixed thereto, although any suitable material for the windows may be used.

24

25 Light from an infrared laser source 11, in this example a mid-infrared optical parametric
26 oscillator source outputting 70mW at approximately 3306nm (although it will be readily
27 apparent that any other suitable infrared light source may be employed), is directed
28 through the apertures to a detector 13. This particular wavelength coincides with the O-H
29 and C-H stretch absorption bands of ethanol, and accordingly transmission through the
30 vessel gives an indication of the presence of ethanol within the vessel. The detector 13, in
31 this case a laser power meter, is connected to a data logger (not shown), for example a
32 PC with a suitable data acquisition card, to record transmitted power as a function of time.

33

34 In use, a background level for determining relative transmission or absorption is obtained
35 without the cask 5 present in the vessel 3, although the background measurement could

1 be taken immediately after the cask 5 is placed in the vessel 3 (before or after the lid 7 is
2 in place) before any significant ethanol leakage occurs. Subsequently, the lid 7 is secured
3 in place, creating a seal. As noted above, ethanol will leak out of the cask 5 in the form of
4 ethanol vapour, which results in absorption of the laser light within the vessel 3. This
5 absorption is detected by way of a reduction in optical power through the vessel 3,
6 detected by the detector 13.

7

8 It is envisaged that an alternative embodiment of the invention comprises the laser source
9 and power meter housed inside the vessel, in which case the apertures are not required.
10 It is also envisaged that the monitoring system of the invention may be employed as a
11 stand-alone monitoring system separate from a vessel, and employed to monitor fluid loss
12 from a cask by detecting the presence of, say, ethanol vapour proximal to the cask.

13

14 Figure 2 illustrates an exemplary graph 21 of relative transmission 23 as a function of time,
15 illustrating the leak rate of ethanol vapour from a test cask (5) housed within a vessel.
16 Relative transmission is determined by dividing the measured optical power at time t with
17 the background measurement obtained at the start of the process.

18

19 The applicant has noted that the leak rate decays over time, tending towards a plateau or
20 continuum value at which leakage from the cask will cease. Extrapolation of a fit to the
21 experimental data, indicated by reference number 25, in this example indicates that
22 equilibrium would be reached within two to three days. At this stage the leakage from the
23 cask has stopped and the amount of ethanol vapour is fixed.

24

25 It is envisaged that instead of two apertures providing a pass-through, a single aperture
26 may be provided with a retro-reflecting mirror inside the vessel – for example on the
27 opposing side of the vessel from the single aperture. The advantage would be two-fold;
28 the absorption pathlength (and hence, sensitivity) would be doubled and the vessel could
29 be monitored from one side.

30

31 The whisky cask 5 is shown sitting horizontally within the vessel, however it will be
32 understood that the cask 5 may sit vertically or at any other orientation. Furthermore,
33 while the vessel 3 is illustrated as being a rectangular box, any other suitable shape of
34 container may be employed. For example, it may be useful to be cylindrical or cask-
35 shaped in order to conform to existing storage facilities. Furthermore, while the vessel of

1 this exemplary embodiment has been described as comprising aluminium, any other
2 suitable material may be employed.

3

4 Of course a vessel may be sized to accommodate multiple whisky casks; a particular
5 advantage being that the maturation process can be monitored and controlled for all said
6 whisky casks at once, thus improving consistency of product between casks. Alternatively,
7 several vessels could be linked by conduits such that conditions are shared throughout,
8 whereupon a single one of said vessels could be monitored as described herein in the
9 knowledge that conditions within or changes made to that vessel will correspond with or
10 result in corresponding changes in conditions in the linked vessels.

11

12 While the exemplary embodiment has been described as monitoring the presence of
13 ethanol within the vessel volume using a laser and a power meter, other useful information
14 may be gleaned by employing a spectrometer or spectrophotometer to analyse the
15 atmospheric composition within the vessel. The spectrometer may be of any suitable kind,
16 for example a tuneable diode laser absorption spectrometer or an active infrared
17 hyperspectral imaging system such as the Applicant's intra-cavity optical parametric
18 oscillator based system. Thus, a detailed analysis of the composition of the atmosphere
19 within the vessel might be determined in real-time.

20

21 The foregoing description of the invention provides an apparatus and a method that first
22 and foremost prevents fluid loss from the cask once an equilibrium position has been
23 reached.

24

25 By addition of a monitoring means, such as a light source and corresponding detector, the
26 apparatus and method also allows the level of ethanol vapour leaking from the cask to be
27 monitored. Optionally, the atmospheric composition can also be determined. The cask is
28 also protected from external influences such as airborne pollutants.

29

30 Furthermore, the invention provides for a system and a method for controlling the
31 maturation process. It has been found that simply sealing casks, for example by shrink-
32 wrapping, does eliminate fluid loss however it also affects the maturation process because
33 ingress of air into the cask from the surroundings is also prevented. This is expected to be
34 of significant detriment to the taste of the whisky – whisky should be allowed to “breathe”
35 as it matures.

1
2 To remedy this issue, the vessel provides an expansion volume. Furthermore,
3 environmental conditions within the vessel 3, and particularly the expansion volume, can
4 be controlled throughout the maturation period. The system comprises a control system
5 that allows the pressure within the vessel 3 to be controlled, as well as the relative
6 humidity and atmospheric composition and of course temperature. This control may
7 comprise maintaining the same environmental conditions throughout an entire maturation
8 process or alternatively varying the environmental conditions as required. By controlling
9 the environmental conditions the maturation process of the whisky can also be controlled.

10

11 It is envisaged that substances may be added to the vessel during the maturation process
12 to simulate desirable atmospheric conditions. For example, salt water could be injected to
13 simulate the sea air of a shore-side maturation location.

14

15 In a particular embodiment of the invention, the control system is used to maintain a small
16 positive atmospheric pressure within the sealed vessel. Accordingly, the fluid loss from
17 the cask resulting from the angels' share is minimised while still allowing for air (oxygen)
18 ingress into the cask to allow the whisky to mature properly.

19

20 As an extension of this embodiment, the vessel may be sized to provide sufficient
21 atmospheric oxygen for an entire maturation process or portion thereof. As described
22 above, the partial pressure of ethanol within the vessel resulting from the angels' share will
23 plateau over the course of, say, a few days yet proper oxygenation is provided for over the
24 course of a number of years. If necessary, the vessel can be purged and refilled every few
25 years. Even with regular purging, the anticipated loss to the angels' share will be
26 significantly reduced over the entire maturation process.

27

28 By way of example, it is found that the ratio of water loss to ethanol loss from a cask is
29 dependent on the prevailing atmospheric conditions; principally relative humidity and
30 temperature, although other conditions may also have an effect. For example, higher
31 temperatures are found to increase losses of both ethanol and water. Higher humidity
32 results in increased ethanol loss (relative to water) and lower humidity results in increased
33 water loss (relative to ethanol). The system described herein allows these conditions
34 (temperature and relative humidity) to be controlled, thus controlling the maturation
35 process.

1

2 One particular use for this system will be in the event that testing during the maturation
3 process reveals some issue with the whisky that can be remedied by varying the
4 atmospheric conditions. For example, if it was deemed that increased water loss was
5 required, relative humidity could be reduced. In this way, a specific ethanol content can be
6 targeted, particularly during the final stages of the maturation process. This may, for
7 example, be used to increase alcohol content of whisky or to reduce the alcohol content of
8 wine in the final product – as is often required in the industry.

9

10 A further application of the present invention is to detect leaks in a cask, whereby the cask
11 is inserted into the vessel and leakage into the vessel monitored as a function of time to
12 determine the presence of a leak and quantify the extent of the leak. This is preferably
13 carried out before filling with whisky – for example by filling with a test gas. It is envisaged
14 that imaging systems (such as the applicant's active infrared hyperspectral imaging
15 system) may be employed to identify the location and/or the size of any leaks in the cask.

16

17 The invention provides an apparatus and a method that reduces fluid loss from a cask
18 during a maturation process by sealably enclosing the cask in a vessel that provides an
19 expansion volume to receive fluid vapour from the cask, a monitoring system and a
20 method that monitors fluid loss from a cask during a maturation process using a light
21 source and a detector to determine the presence of fluid vapour in the vicinity of the cask,
22 a corresponding system for controlling a maturation process in which environmental
23 conditions are controlled, and a cask leak testing system and method making use of the
24 above.

25

26 Various modifications may be made within the scope of the invention as herein intended.
27 For example, and as stated above, while specific examples are described in relation to the
28 maturation of whisky in casks, similar apparatus, methods and systems may be employed
29 in the maturation of bourbon and other spirits, wines, other alcoholic beverages, and other
30 fluids (e.g. balsamic vinegar) that are matured in casks.

31

1 Claims:

2

3 1. An apparatus to reduce fluid loss from a cask during a maturation process, the
4 apparatus comprising:
5 a vessel to sealably enclose the cask and provide an expansion volume to receive
6 fluid vapour that has escaped from the cask; and
7 a monitoring system arranged to monitor the presence of the fluid vapour in the
8 expansion volume within the vessel that has escaped from the cask;
9 wherein the monitoring system comprises a light source and a detector, the detector
10 arranged to receive light from the light source and the monitoring system configured
11 to determine a relative transmission of the light through the vessel.

12

13 2. The apparatus according to claim 1, wherein the monitoring system is configured to
14 monitor fluid vapour leak rate as a function of time.

15

16 3. The apparatus according to claim 1 or claim 2, wherein the apparatus comprises at
17 least one aperture in a wall of the vessel, the light source and detector arranged on
18 opposite sides of the aperture.

19

20 4. The apparatus according to claim 1 or claim 2, wherein the apparatus comprises two
21 apertures located in walls of the vessel and defining an optical path through the
22 vessel intersecting the light source and the detector.

23

24 5. The apparatus according to claim 1 or claim 2, wherein the apparatus further
25 comprises a mirror arranged to receive and reflect light from the light source to the
26 detector via a same aperture.

27

28 6. The apparatus according to any one of claims 3 to 5, wherein the at least one
29 aperture comprises a window.

30

31 7. The apparatus according to claim 6, wherein the window comprises CaF_2 .

32

33 8. The apparatus according to any one of claims 1 to 7, wherein the light source
34 comprises a laser source.

35

36 9. The apparatus according to any one of claims 1 to 8, wherein the light source
37 comprises an infrared laser source.

- 1
2 10. The apparatus according to any one of claims 1 to 9, wherein the light source
3 comprises an optical parametric oscillator mid-infrared source.
4
5 11. The apparatus according to any one of claims 1 to 9, wherein the light source
6 comprises a quantum cascade laser source.
7
8 12. The apparatus according to any one of claims 1 to 11, wherein the light source is
9 tuned to an absorption line or absorption band of ethanol.
10
11 13. The apparatus according to any one of claims 1 to 12, wherein the monitoring
12 system comprises an active infrared hyperspectral imaging system.
13
14 14. The apparatus according to any one of claims 1 to 13, wherein the vessel comprises
15 a lid.
16
17 15. The apparatus according to claim 14, wherein at least one of the lid and the main
18 body of the vessel is provided with a rubber gasket or O-ring to provide a seal there
19 between.
20
21 16. The apparatus according to any one of claims 1 to 15, wherein the vessel is
22 rectangular.
23
24 17. The apparatus according to any one of claims 1 to 15, wherein the vessel is
25 cylindrical or cask-shaped.
26
27 18. The apparatus according to any one of claims 1 to 17, wherein the vessel is sized to
28 receive a plurality of casks.
29
30 19. The apparatus according to any one of claims 1 to 18, wherein the vessel is in fluid
31 communication with one or more like vessels with or without respective monitoring
32 systems.
33
34 20. A method of reducing fluid loss from a cask during a maturation process, the method
35 comprising:
36 sealing the cask within a vessel having an expansion volume, and receiving fluid
37 vapour from the cask in the expansion volume of the vessel;
38 monitoring the presence of the fluid vapour within the expansion volume of the

- 1 vessel that has escaped from the cask using a light source and a detector, the
2 detector arranged to receive light from the light source; and
3 determining a relative transmission of the light through the vessel.
4
- 5 21. The method according to claim 20, further comprising monitoring the presence of
6 ethanol within the sealed vessel.
7
- 8 22. The method according to claim 20 or claim 21, further comprising monitoring the
9 presence of water vapour within the sealed vessel.
10
- 11 23. The method according to any one of claims 20 to 22, further comprising obtaining a
12 background measurement of the presence of ethanol within the sealed vessel.
13
- 14 24. The method according to any one of claims 20 to 23, further comprising recording
15 the presence of ethanol within the sealed vessel as a function of time.
16
- 17 25. A system for controlling a maturation process, the system comprising the apparatus
18 of any one of claims 1 to 19 and a control system configured to control
19 environmental conditions within the sealed vessel.
20
- 21 26. The system according to claim 25, wherein the vessel is sized to provide sufficient
22 atmospheric oxygen for at least a portion of the maturation process.
23
- 24 27. The system according to claim 25 or claim 26, wherein the vessel is sized to provide
25 sufficient water vapour for at least a portion of the maturation process.
26
- 27 28. The system according to any one of claims 25 to 27, wherein the system comprises
28 at least one pump operable to control an ambient pressure within the vessel.
29
- 30 29. The system according to claim 28, wherein the pump is operable to maintain a target
31 ambient pressure within the vessel.
32
- 33 30. The system according to any one of claims 25 to 29, wherein the system comprises
34 one or more gas sources in fluid communication with the vessel, operable to control
35 the presence of one or more gases within the vessel.
36

- 1 31. The system according to any one of claims 25 to 30, wherein the system further
2 comprises at least of one or more heating and one or more cooling devices
3 configured to control a temperature of the vessel.
4
- 5 32. A method of controlling a cask maturation process, comprising sealing the cask
6 within a vessel, controlling environmental conditions within the sealed vessel, and
7 monitoring the presence of the fluid vapour within the vessel using a light source and
8 a detector, the detector arranged to receive light from the light source; and
9 determining a relative transmission of the light through the vessel.
10
- 11 33. The method according to claim 32, further comprising controlling the temperature
12 within the vessel.
13
- 14 34. The method according to claim 32 or claim 33, further comprising controlling the
15 atmospheric pressure within the vessel.
16
- 17 35. The method according to any one of claims 32 to 34, further comprising adding one
18 or more gases to the vessel.
19
- 20 36. The method according to any one of claims 32 to 35, further comprising adding one
21 or more substances selected to simulate a geographic location during maturation.
22
- 23 37. The method according to any one of claims 32 to 36, further comprising maintaining
24 a positive atmospheric pressure within the vessel.
25
- 26 38. The method according to any one of claims 32 to 37, further comprising controlling a
27 partial pressure of water vapour within the vessel to control the relative loss of water
28 versus ethanol from the cask.
29
- 30 39. The method according to any one of claims 32 to 38, further comprising periodically
31 purging the vessel.
32
- 33 40. A cask leak testing system, comprising the apparatus of any one of claims 1 to 19.
34

- 1 41. The cask leak testing system according to claim 40, further comprising imaging
2 means configured to obtain one or more images of the cask to identify the location
3 and size of one or more leaks in the cask.
4
- 5 42. The cask leak testing system according to claim 41, wherein the imaging means
6 comprises an active infrared hyperspectral imaging system.
7
- 8 43. A method of testing a cask for leaks, comprising sealing the cask within a vessel of
9 one any of claims 1 to 19 and monitoring leakage into the vessel as a function of
10 time.
11
- 12 44. The method according to claim 43, further comprising filling the cask with a test gas,
13 and detecting the presence of the test gas within the expansion volume of the vessel
14 using the monitoring system.
15

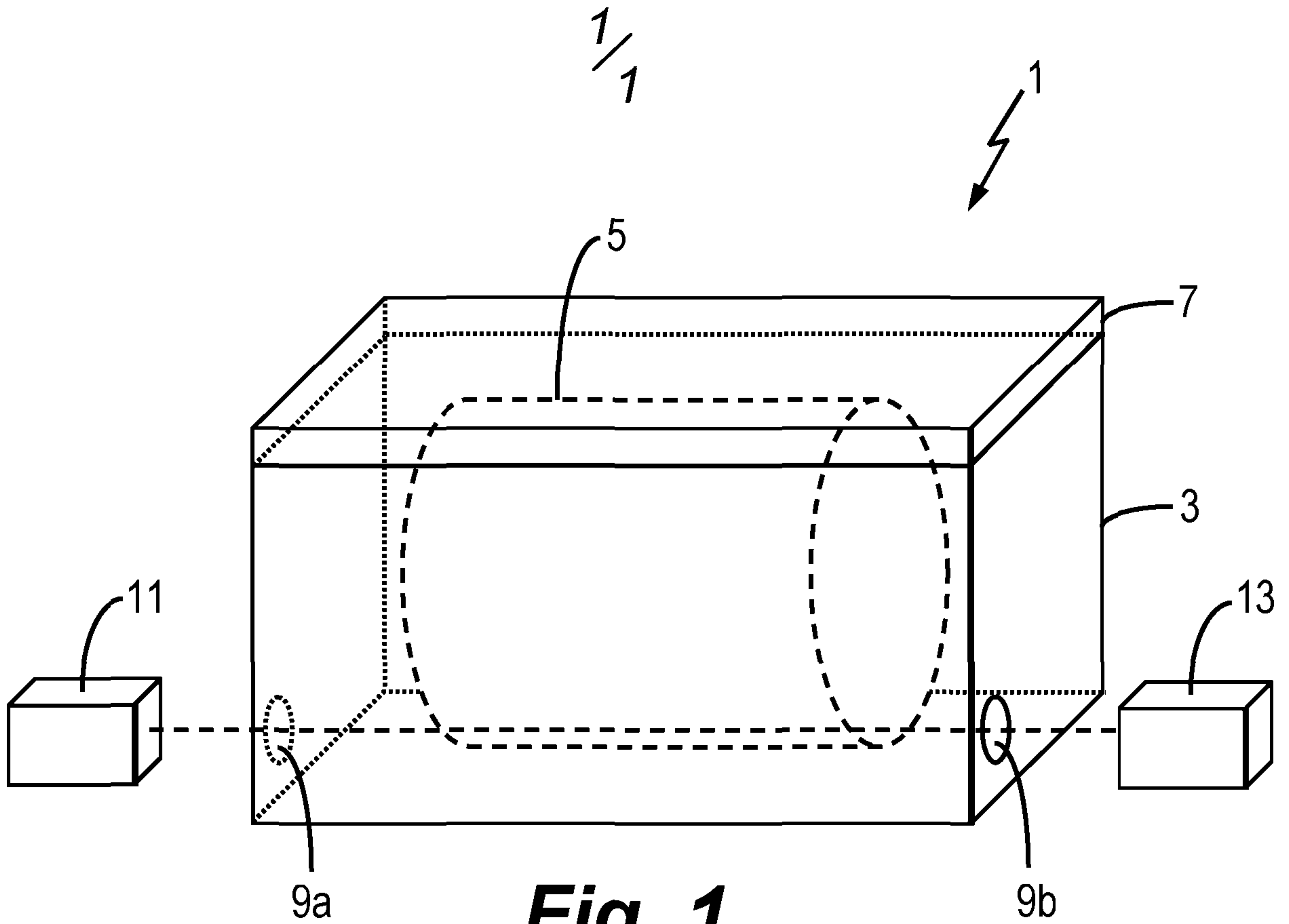

Fig. 1

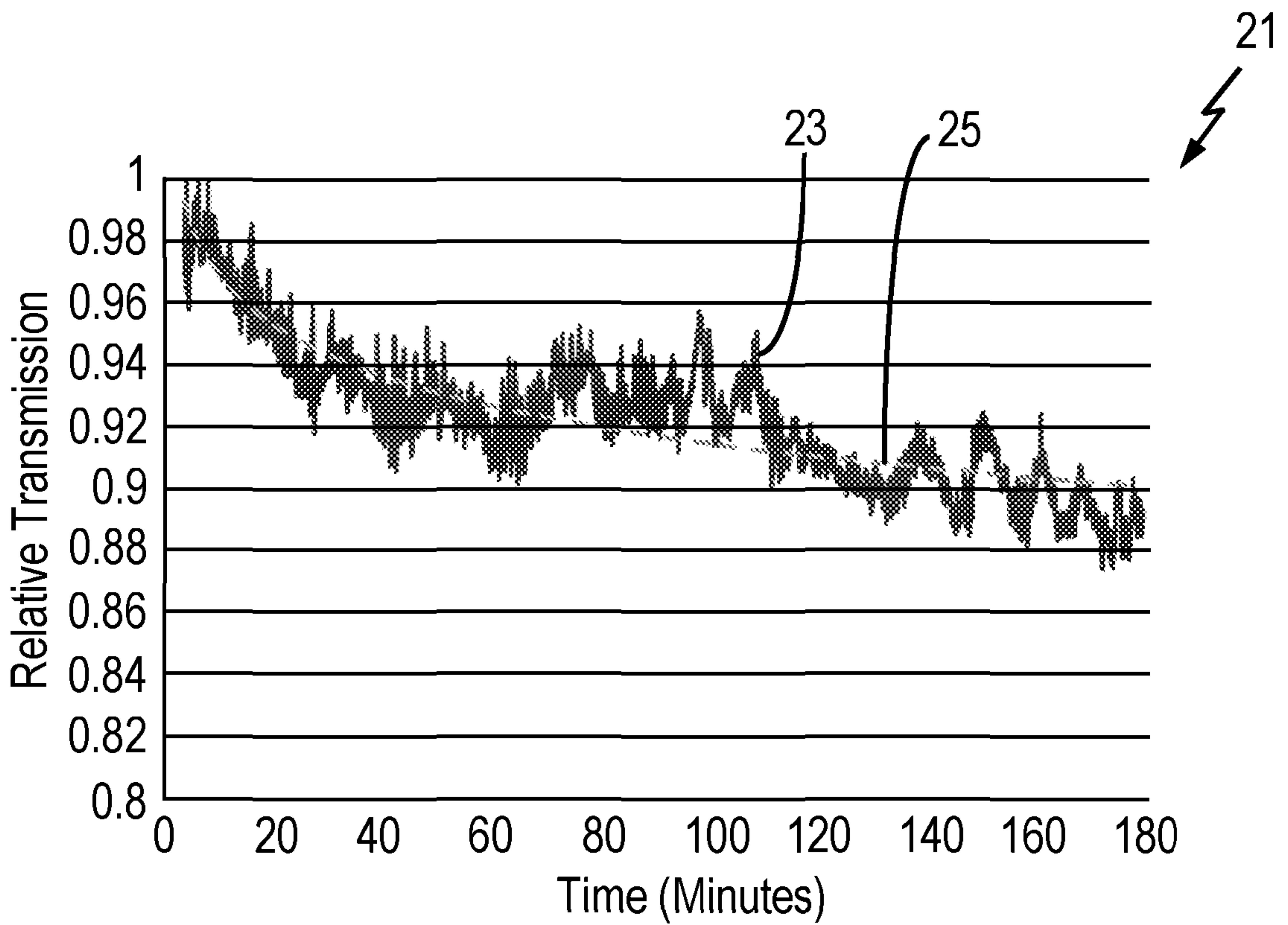

Fig. 2

