

G. WENZELMANN.
PORTABLE FARM DERRICK.

(Application filed Nov. 8, 1899.)

(No Model.)

2 Sheets—Sheet 1.

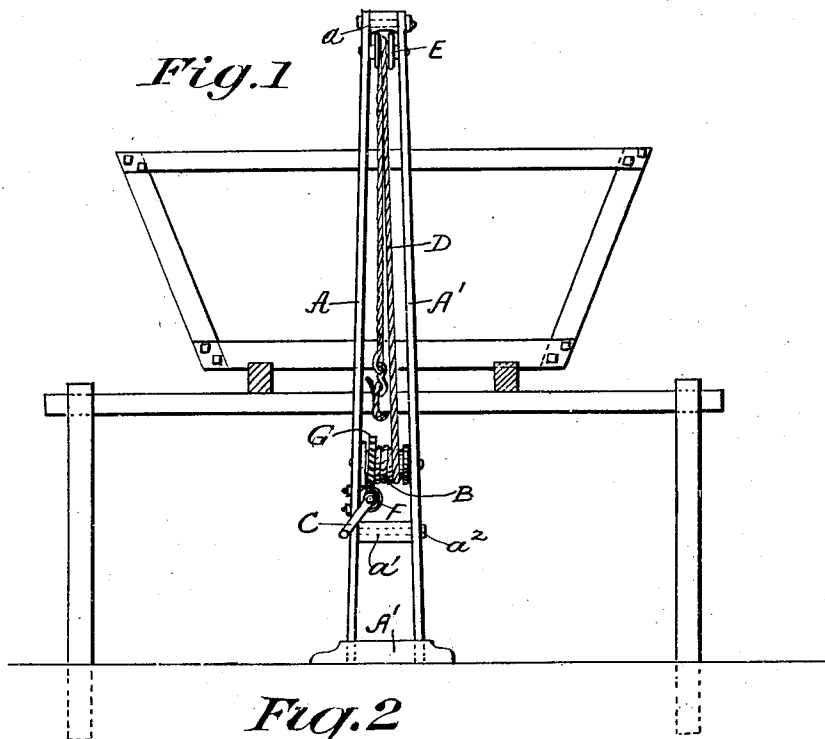
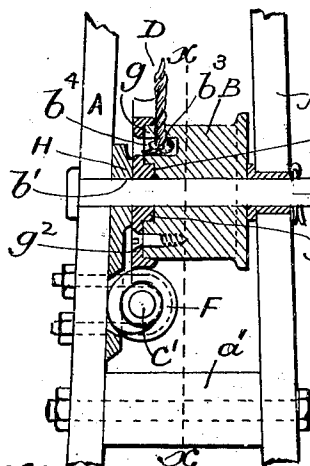

Fig. 3



Witnesses :-
 N. M. Carroll
 M. E. Rowe.

Fig. 2

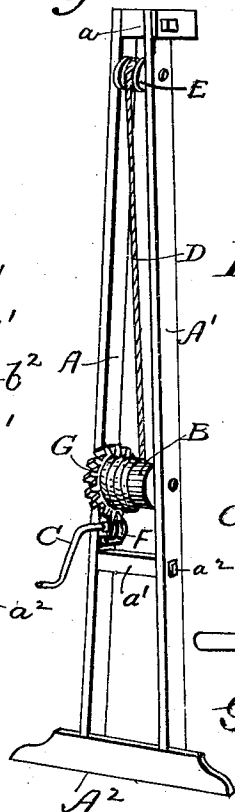

Fig. 5

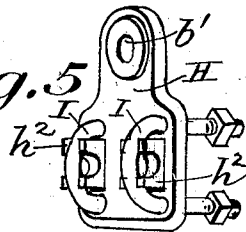
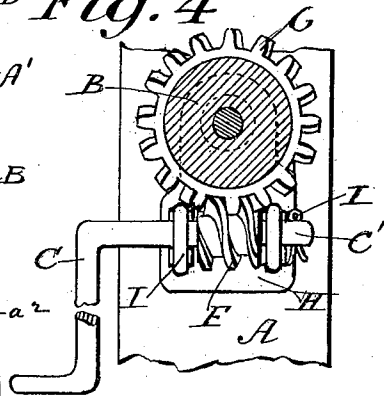

Fig. 4



Inventor :-
 Gustave Wenzelmann
 By his Atty :-
 W. H. Rowe,

No. 660,137.

Patented Oct. 23, 1900.

G. WENZELMANN.
PORTABLE FARM DERRICK.

(Application filed Nov. 8, 1899.)

(No Model.)

2 Sheets—Sheet 2.

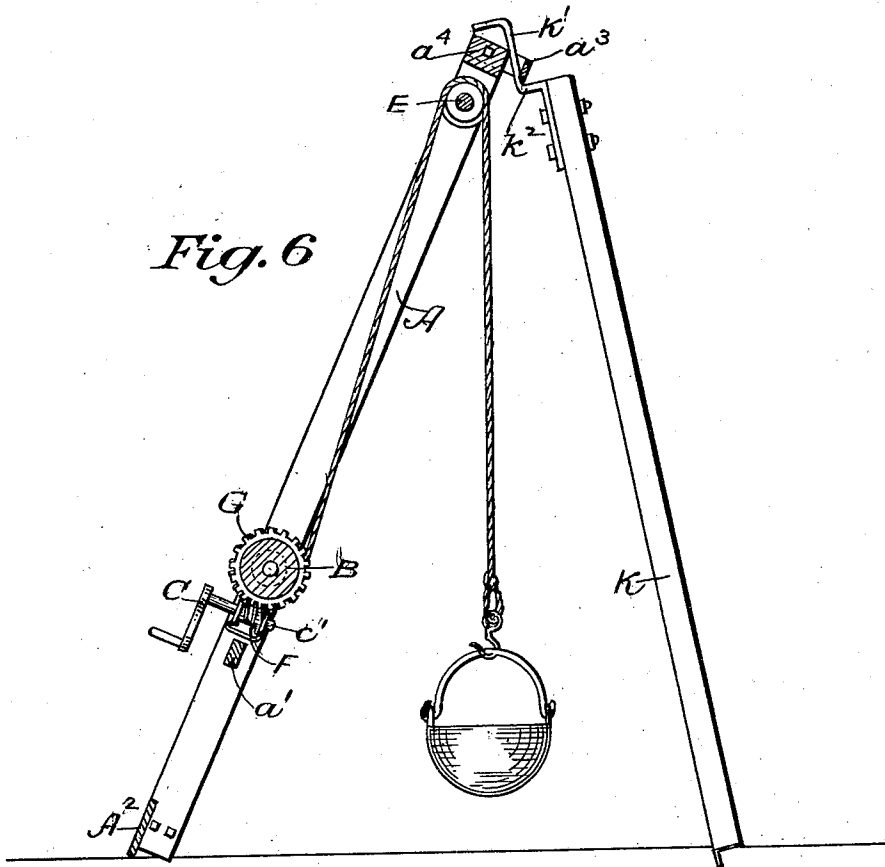

Fig. 6

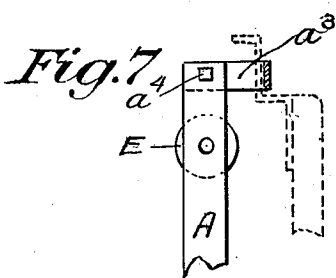

Fig. 7

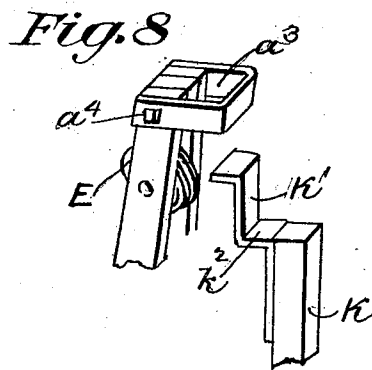

Fig. 8

Witnesses:-

N. M. Carroll

M. E. Rowe

Inventor:-

Gustave Wenzelmann

By his Atty., Wm. H. Rowe

UNITED STATES PATENT OFFICE.

GUSTAVE WENZELMANN, OF STREATOR, ILLINOIS.

PORTABLE FARM-DERRICK.

SPECIFICATION forming part of Letters Patent No. 660,137, dated October 23, 1900.

Application filed November 8, 1899. Serial No. 736,249. (No model.)

To all whom it may concern:

Be it known that I, GUSTAVE WENZELMANN, a citizen of the United States, residing at Streator, in the county of La Salle and State of Illinois, have invented certain new and useful Improvements in Portable Farm-Derricks, of which the following is a specification.

My invention relates to a light lifting-derrick which may be easily carried about by hand and stored away compactly in a light wagon or other out-of-the-way place convenient for use, as for lifting a wagon or carriage from the ground or lifting a hay-rack from the running-gear of a wagon and for general use whenever the body is too heavy to be lifted by one or two persons.

The object of my invention is primarily to provide a very light, strong, and inexpensive device made of a few simple and inexpensive parts which may be easily assembled and not liable to get out of order, which may be operated by any one with little effort or experience, and which will securely hold the load at all times without the use of ratchet or other stop or locking mechanism, to which end my invention consists in certain constructions and combinations of parts hereinafter particularly described and claimed with reference to the accompanying drawings, wherein—

Figure 1 is an end elevation of a hay-rack supported by a cross-bar upon the upper end of two posts driven into the ground, with my improved derrick in position for lifting the rack; Fig. 2, a perspective view of the derrick; Fig. 3, an enlarged sectional front elevation of the drum, worm-crank, and adjacent sections of the frame-pieces; Fig. 4, a sectional elevation in line xx of Fig. 3; Fig. 5, an enlarged perspective view of the gear-plate box and strap-bolts in detail; Fig. 6, a side elevation, partly broken away, of my improved derrick with a supporting-bar connected by novel means to the upper ends of the frame-strips; Fig. 7, a side elevation, broken away, showing the upper end of the frame-strips and the improved strap for connecting the derrick-frame to the supporting-post, a coupling-plate being shown by dotted lines in position to be connected to the derrick-frame; and Fig. 8, a perspective view of

the parts shown by full and dotted lines in Fig. 7.

The derrick consists of two wooden strips $A A'$, connected at the top by a block a and at the bottom by a foot-strip A^2 , and also connected by a cross-piece a' and tie-bolt a^2 at a suitable distance from the foot-strip and directly below a drum B and gear-cranks C , which provides simple means for winding a rope D , to which the body to be lifted is attached. The rope D passes over a roller E , supported at the upper ends and between the uprights $A A'$, which will give the derrick sufficient height to lift the rack or other body to any ordinary distance above the ground.

The gearing for operating the drum and the novel means for attaching the same to the wooden upright A are very simple and inexpensive and will enable a child to lift a very heavy weight and hold the weight with perfect safety, the crank C being always held still unless turned by the operator without the use of pawls and ratchets or other stop mechanism.

The crank C has a worm F cast thereon, which engages a worm-gear G , secured in a simple manner to the wooden drum B , the worm thus serving to thus turn the gear and drum and hold them without other locking device connected therewith in any position in which they are placed while the load is being lifted and supported. The worm-gear G is recessed at g to receive, and is provided with the studs g' to enter, the adjacent end of the wooden drum and has holes g^2 to receive screws which pass through the said gear and into the end of the said drum, thus providing a simple and strong connection.

The crank-shaft c' and drum-shaft b^2 are both held securely to the frame-strip A by means of a gear-plate H , (shown in detail in Fig. 5,) the said plate having a bearing b' to receive the drum-shaft b^2 and pillow-blocks $h^2 h^2$ projecting therefrom to receive the crank-shaft c' , staples II upon each of said pillow-blocks passing through holes in the gear-plate H , thus providing a bearing for the shaft and also serving to hold the gear-plate H securely upon the frame A of the derrick.

The metal parts do not need finishing and will fit snugly and operate smoothly together.

There are very few parts. A minimum weight of metal and any required height may be given to the frame-strips without materially increasing the weight.

5 The rope is securely attached to the drum by passing one of the ends thereof first into a radial hole b^3 and then out of a longitudinal connecting-hole b^4 , a knot being then tied in the end of the rope and then drawn into the
10 longitudinal hole in the drum. The derrick-frame is provided with a supporting-bar K, which may be readily attached and detached therefrom and securely locked by means of a zigzag plate K', secured to the upper end of
15 the said bar K, the outer elbow K' of said plate being adapted to pass freely through a strap a^3 , secured by a bolt a^1 to the upper end of the frame A, the inner elbow k^2 providing a shoulder upon which the said loop may rest. The
20 inner elbow k^2 is sufficiently wide to provide a perfectly secure seat for the loops of the derrick-frame, and thus make the latter safe and strong, while the pole may be readily connected and disconnected therefrom without
25 removing bolts or other fixtures. A light working device adapted for general use may thus be provided with few parts securely put together at an extremely low cost.

30 I claim as my invention and desire to secure by Letters Patent—

1. In a portable frame-derrick, the combination with the two frame-strips of the drum having a worm-gear secured to the end thereof, a crank-shaft and worm thereon, and a gear-plate having pillow-blocks to receive the
35 said crank-shaft and staples to fit over said pillow-blocks and pass through the gear-plate and upright, and nuts thereon to clamp the said parts together, substantially as described.

2. In a winding-gear for portable farm-derricks, the combination of the roller-block having a radial and an intersecting end hole therein, a knotted rope secured therein and a worm-gear plate secured to the end thereof by means
40 of screws and stud projections, substantially as described.

3. In a portable farm-derrick, the combination with the frame-strip having a loop secured to the upper end thereof, of a drum at the lower end thereof, a pulley located at the
50 upper end thereof, a rope secured to the drum and a supporting-bar having a zigzag plate at the upper end thereof to interlock with the loop at the upper end of the frame, substantially as described.

GUSTAVE WENZELMANN.

Witnesses:

F. PLUMB,

ED. H. OVERHOLT.