

(No Model.)

G. T. WOODS.

OVERHEAD CONDUCTING SYSTEM FOR ELECTRIC RAILWAYS.

No. 383,844.

Patented May 29, 1888.

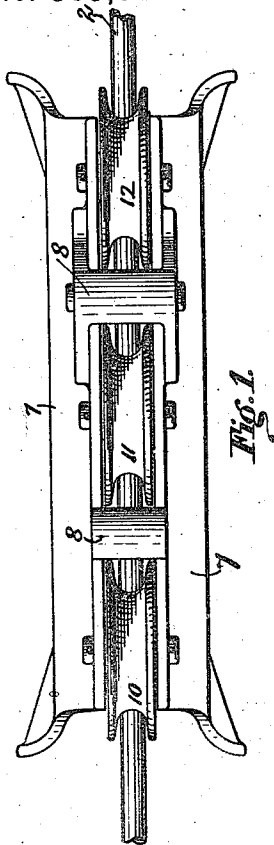

Fig. 1.

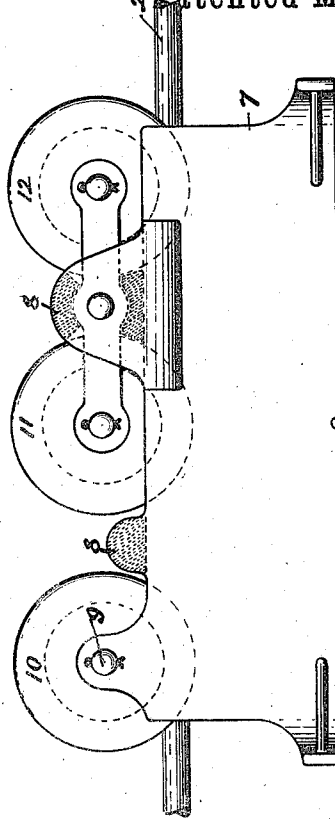

Fig. 2.

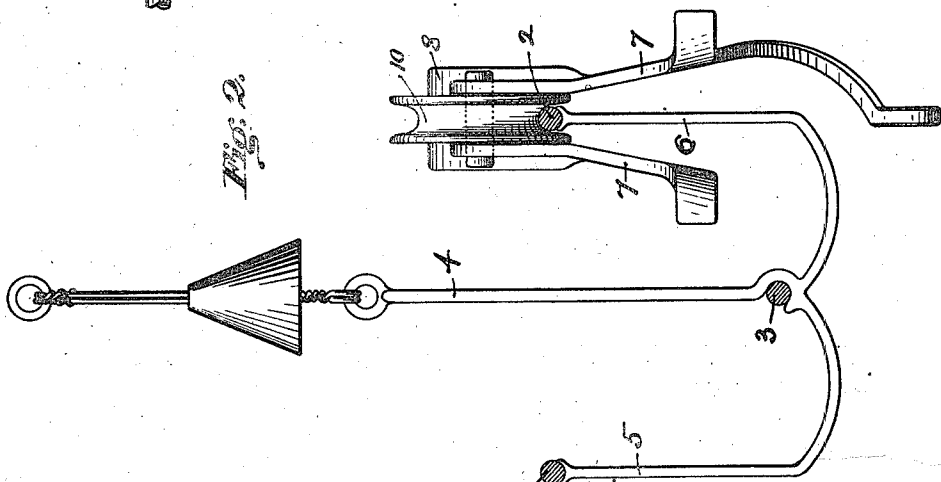

Fig. 3.

Attest.
C. H. Bogart
C. S. Mumfory

Granville T. Woods, Inventor.
G. R. Kellstrom, Atty.

UNITED STATES PATENT OFFICE.

GRANVILLE T. WOODS, OF CINCINNATI, OHIO, ASSIGNOR TO THE WOODS ELECTRIC COMPANY, OF SAME PLACE.

OVERHEAD CONDUCTING SYSTEM FOR ELECTRIC RAILWAYS.

SPECIFICATION forming part of Letters Patent No. 383,844, dated May 29, 1888.

Application filed May 2, 1887. Serial No. 234,776. (No model.)

To all whom it may concern:

Be it known that I, GRANVILLE G. WOODS, a citizen of the United States, residing at Cincinnati, Ohio, have invented new and useful Improvements in Overhead Conducting Systems for Electric Railways, of which the following is a specification.

My invention relates to traveling electric contacts and overhead conductors employed in electro-motive railways; and it consists in the construction hereinafter described and illustrated.

Mechanism embodying my invention is shown in the accompanying drawings, in which—

Figure 1 is a plan view of the carriage; Fig. 2, a cross-sectional elevation of the suspended conducting-wires with one of the hangers supporting the same, and an end view of a carriage in position; and Fig. 3, a side elevation of a carriage in position.

Referring now to the drawings, the electric conducting-path is composed of three conducting-wires carried upon insulated hangers 4. The hanger terminates below in two upwardly-projecting arms, 5 6, these two arms carrying upon their upper extremities iron wires 1 and 2, and between the two arms at the lower extremity of the stem 4 is carried a copper wire, 3. The contact carriages for a double-track line of railway run upon the outer wires, 1 and 2, while the central wire, 3, carries the main current from the generator, which is transmitted through the metallic arms 5 and 6 to the wires 1 and 2. By this construction I am able to utilize lighter wires, yet obtain a largely-increased conducting capacity and consequently less resistance.

The carriage consists of a light frame, preferably of cast-iron, consisting of two side pieces, 7 7, connected by cross-braces 8 8. Between the side pieces, 7 7, upon connecting-studs 9, are carried the grooved running-wheels 10 11 12, the two latter being secured in a pivoted truck, as shown. The object of the latter arrangement is to preserve a constant electrical contact without danger of interruption from inequalities in the alignment of the carrying-wires or any accidental causes. The sides of the carriage are extended downward and some-

what outward, to serve as balancing-weights to preserve the carriage in its normal vertical position, and the projecting forward and rear ends of the side pieces, 7, are flared outward to guide the carriage past the arms 5 6 in case of accidental swaying of the carriage from side to side. One of the side pieces is projected still farther downward centrally and curved inward to the central vertical plane of the carriage and its carrying-wire, for the attachment of the car connection.

Connection is made with the car by means of a spring-clamp, 13, attached by means of a wire cable, 14, to the traveling carriage. The clamp is a piece of spring metal in U form with its jaws brought together, as indicated in Fig. 3. Its clamping power is sufficient to maintain the connection with the car, yet to give way and release the carriage in case of an accidental stoppage of the carriage without injury to the conducting-line.

I claim as my invention and desire to secure by Letters Patent of the United States—

1. An "overhead" conducting-path for electro-motive railways, embodying, essentially, a central conductor carried by insulated metallic brackets, and one or more wires for carrying the contact-carriage, held upon suitable arms of said brackets, whereby the current delivered to the first-named conductor is transmitted by and through the bracket-arms to the carrying conductor or conductors, substantially as set forth.

2. In overhead conductors for electro-motive railways, the combination of an insulated suspending-bracket with three conducting-wires—to wit, a central wire connected with the generator and two others supported upon outer arms of the bracket and receiving their charges of current through said suspending-arms from the first wire—substantially as set forth.

3. A bracket for carrying overhead conductors of electro-motive railways, embodying a central stem adapted to engage and hold a central conductor, and one or two outer supporting-arms adapted to uphold the traveling contact-wires and transmit the current from the first-named to the second conductors, substantially as set forth.

4. A traveling contact or carriage for over-

head-conducting systems for electro-motive railways, consisting, essentially, of two conducting side plates or frames joined at the top and carried upon three grooved rollers pivoted
5 between the plates, two of said rollers being carried in a truck so pivoted, substantially as set forth.

5. The traveling contact-carriage for overhead-conducting systems for electro-motive
10 railways, embodying, in combination with its carrying-rollers, two side plates joined together at the top, flaring outward below and at the forward and rear ends, one of said plates hav-

ing a still lower central extension curved inward to the central vertical plane of the carrying-wheels and adapted to receive the motor-connection at the lowest central point, substantially as set forth. 15

In testimony whereof I have hereunto set my hand in the presence of two subscribing witnesses. 20

GRANVILLE T. WOODS.

Witnesses:

L. M. HOSEA,
C. W. BOGART.