

Feb. 27, 1973

J. P. BURGESS ET AL

3,718,892

LAMP SOCKET

Filed Sept. 25, 1969

4 Sheets-Sheet 1

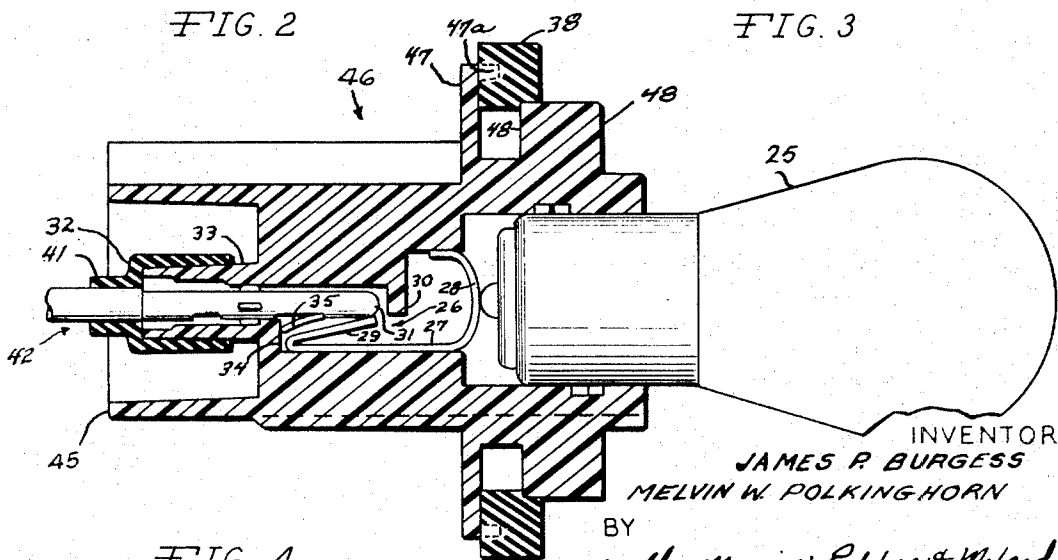
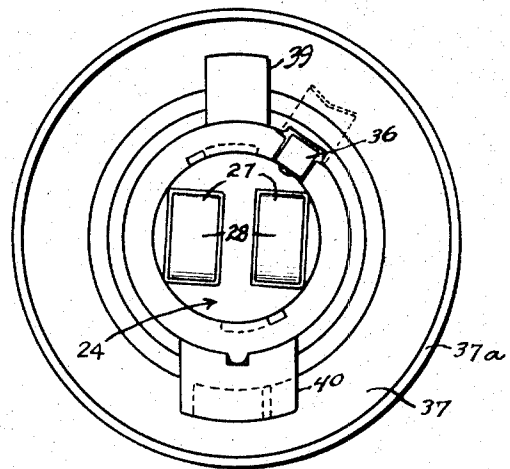
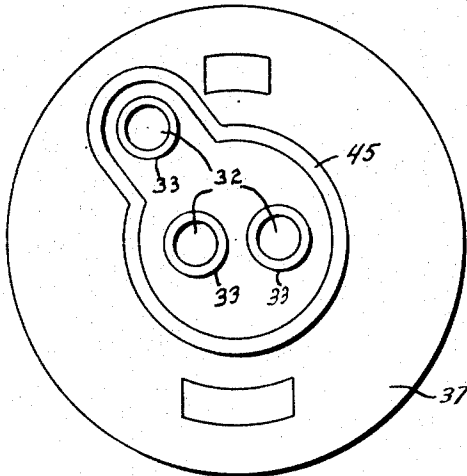
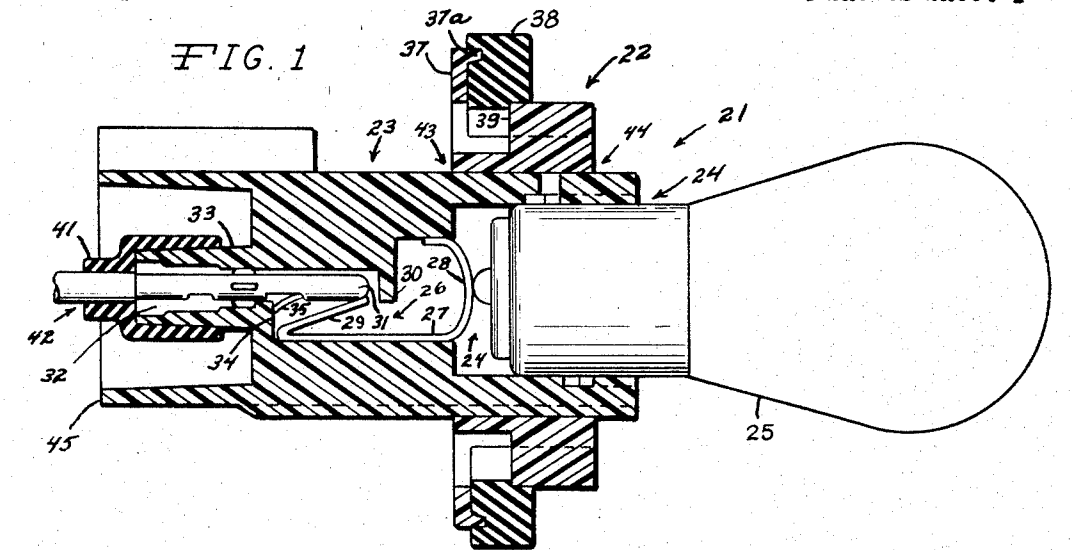

INVENTORS
JAMES P. BURGESS
MELVIN W. POLKINGHORN

BY

Miller, Morris, Pappas & McLeod

ATTORNEYS

Feb. 27, 1973

J. P. BURGESS ET AL

3,718,892

LAMP SOCKET

Filed Sept. 25, 1969

4 Sheets-Sheet 2

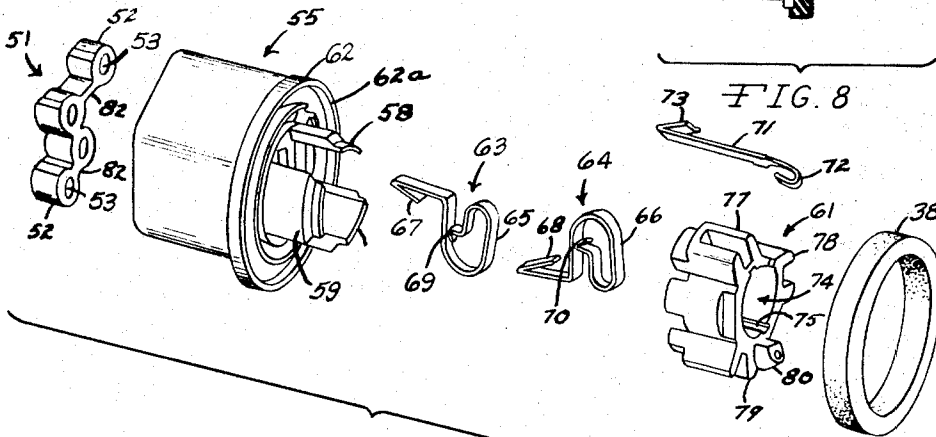
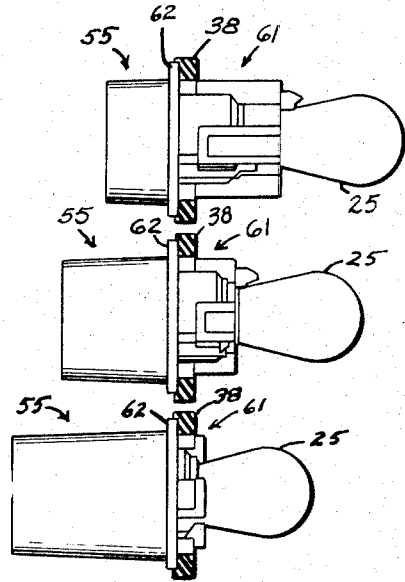
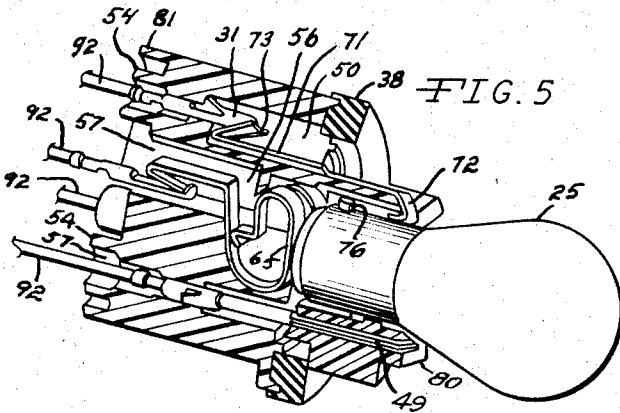

FIG. 6

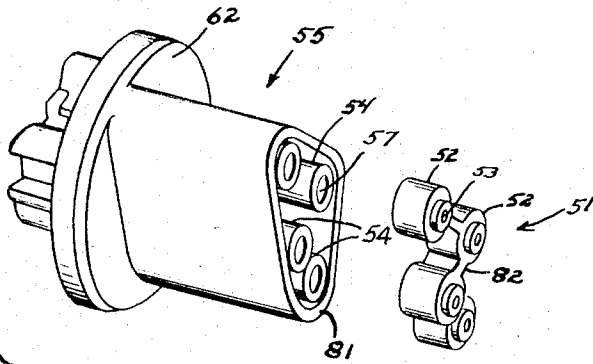

FIG. 7

INVENTORS
JAMES P. BURGESS
MELVIN W. POLKINGHORN

BY

Miller, Morris, Ruppel & McLeod

ATTORNEYS

Feb. 27, 1973

J. P. BURGESS ET AL

3,718,892

LAMP SOCKET

Filed Sept. 25, 1969

4 Sheets-Sheet 3

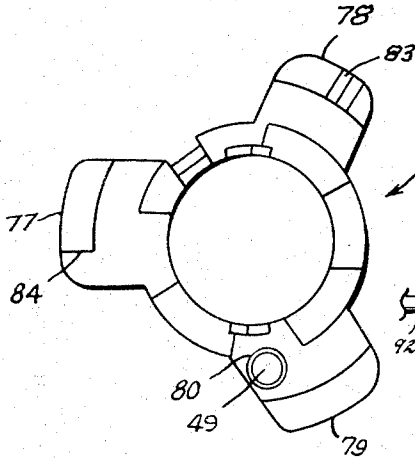

FIG. 9

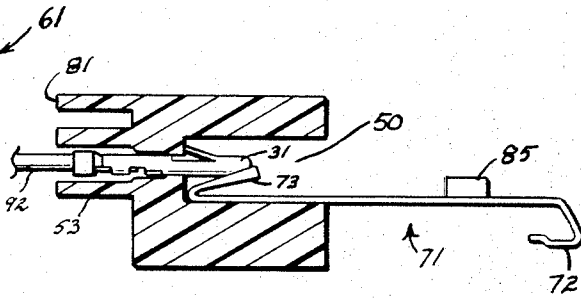

FIG. 10

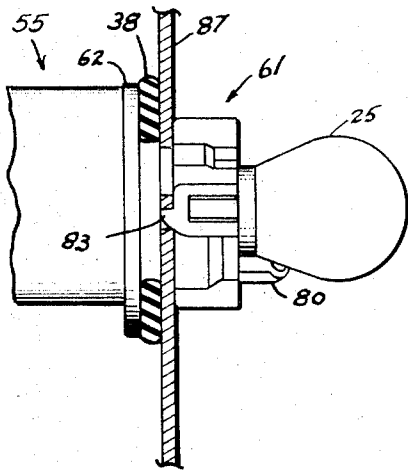

FIG. 12

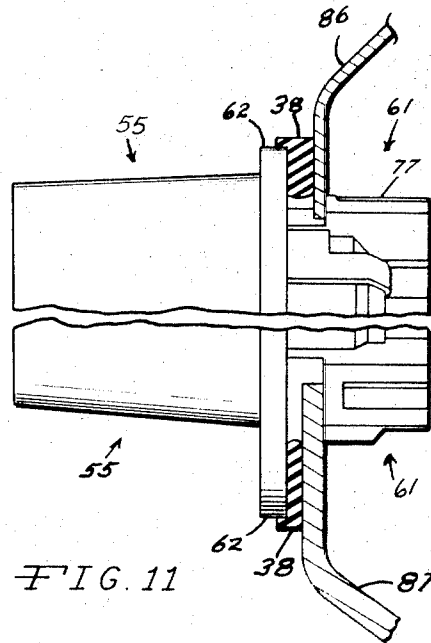

FIG. 11

INVENTORS
JAMES P. BURGESS
MELVIN W. POLKINGHORN
BY
Miller, Morrise, Pappas & McLeod
ATTORNEYS

Feb. 27, 1973

J. P. BURGESS ET AL

3,718,892

LAMP SOCKET

Filed Sept. 25, 1969

4 Sheets-Sheet 4

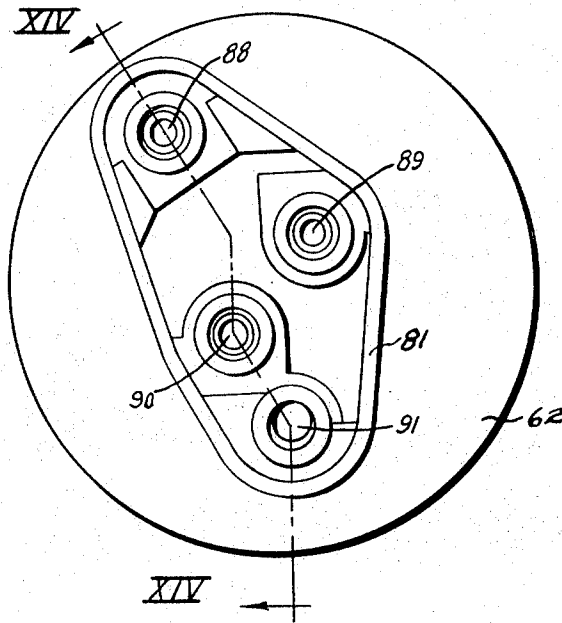

FIG. 13

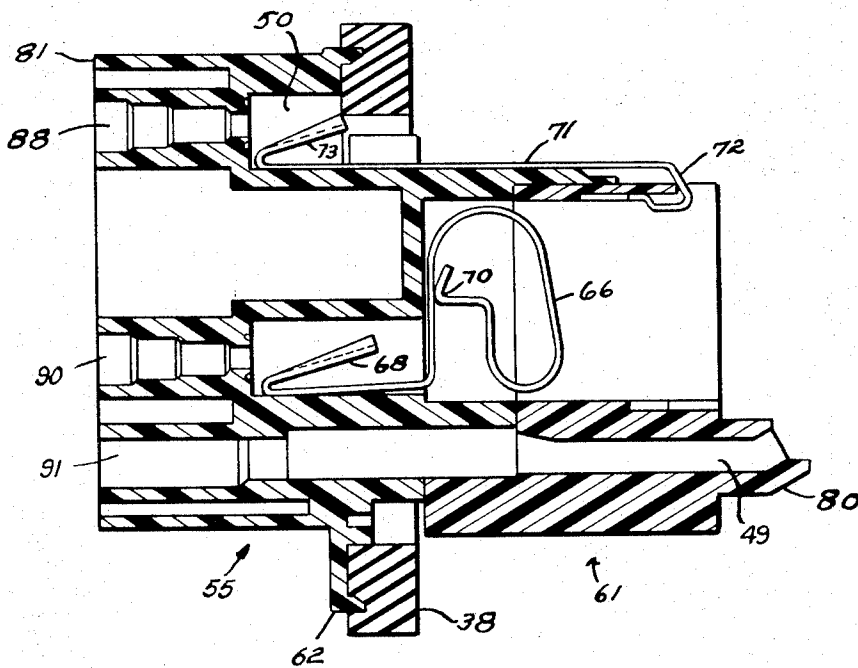

FIG. 14

INVENTORS
JAMES P. BURGESS
MELVIN W. POLKINGHORN

BY
Miller, Monice, Pappas & McLeod

ATTORNEYS

1

2

3,718,892

LAMP SOCKET

James P. Burgess, Brighton, and Melvin W. Polkinghorn, Livonia, Mich., assignors to International Telephone and Telegraph Corporation, New York, N.Y.

Filed Sept. 25, 1969, Ser. No. 861,113

Int. Cl. H01r 13/32, 13/66

U.S. Cl. 339—126 R

35 Claims

ABSTRACT OF THE DISCLOSURE

A lamp socket structure adapted to lockably receive wire harness terminal plugs therein and maintain such terminals in positive wire harness strain-free contact with bulb contact elements positioned within the lamp socket structure. An annular flange, a compression ring and annular shoulders provided on the lamp socket body housing cooperate to provide fool-proof housing panel orientation during installation and positive pressure interlock with the panel housing regardless of housing panel thickness or material. The lamp socket structure has a built-in fibre optic channel which provides one standard ferrule position for all focal lengths and provides for quick insertion, precise aiming and positive locking of the fibre optic wire. The relative axial positioning of the annular flange, compression ring and annular shoulders on the lamp socket body housing can be changed so that the lamp socket structure is axially adjusted relative to the housing panel, thus providing for a variety of focal ranges while maintaining the same basic internal structural features and component interrelationship within the lamp socket structure. A unique boot seal cooperates with socket extension towers on the lamp socket structure to provide for positive individual wire lead sealing.

SUMMARY OF THE INVENTION

This invention relates to an electric lamp socket structure which can be easily, quickly and positively lockably mounted in a lamp housing and, more particularly relates to a lamp socket assembly which is easily and economically fabricated and provides for quick wire harness to socket assembly wherein all internal contact members are independent of external wire harness strain. The lamp socket structure can be adapted to a variety of focal ranges. A unique boot seal cooperates with the lamp socket structure to provide positive individual wire lead sealing.

PRIOR ART

Lamp socket structures of the prior art have been complicated and hence expensive to fabricate. Further, additional excessive expenses are involved in connecting such prior art lamp socket structures to the wire harnesses. Failures have occurred in the field because the contact members of such prior art lamp socket structures have been subject to external wire harness strains.

In addition, the lamp socket structures of the prior art have been difficult to install and maintain in their operative use position in association with the lamp housing and the associated wire harness structure. Thus, failures in the automotive light systems have occurred in use creating dangerous conditions with often disastrous consequences.

Accordingly, a need has existed for a lamp socket structure which is safe and foolproof in operation and yet which is simple and economical to fabricate, assemble and install.

A need has also existed for a simple, easy-to-fabricate lamp socket structure which provides a positive pressure interlock with the housing panel upon which it is mounted, regardless of housing panel thickness and material.

A still further need has existed for a lamp socket structure which can permanently and lockably receive individual wire harness plug terminals therein and maintain such terminals in positive wiping contact with the contact elements provided in the lamp socket structure.

Yet another need has existed for a lamp socket structure wherein bulb contact pressure is independent of wire harness strain occasioned by improper installation or rough usage.

A need has also existed for a lamp socket structure having a built-in fibre optic channel facilitating lamp outage indicator and a capability to provide for a plurality of focal ranges, thereby providing adaptability to various lamp housings and lamp bulb types.

A need has also existed for a lamp socket structure which does not require a reflector (housing) socket opening having irregular surfaces for detenting in order to retain such lamp socket structure in its operative use position.

A need has existed for a lamp socket structure which can be interchangeably used with metal or plastic housings and which is virtually independent of housing thicknesses.

A need has existed for a unique boot seal which cooperates with the lamp socket structure to provide for positive individual wire lead sealing.

A need has existed for a unique boot seal-lamp socket connection which is protected against accidental dislodgment.

Accordingly, the present invention consists of a lamp socket structure which is simple in construction and design but which incorporates therein a positive locking capability with respect to the lamp reflector housing, positive locking with wire harness plug terminals, bulb contact pressure which is independent of external harness wire strains, positive locking of bulb to contacts, positive lamp filament to reflector orientation, a built-in fibre optic channel and a capability for adaptability to variety of lamp styles and base configurations.

It is therefore an object of this invention to provide a lamp socket assembly which is safe and foolproof in operation so as to meet the rigid safety standards imposed on the automotive industry today.

Another object of this invention is to provide a lamp socket structure which insures foolproof socket to instrument panel housing orientation and provides for straight line insertion during installation.

Another object of this invention is to provide a lamp socket structure which is simple and economical to fabricate and assemble.

Another object of this invention is to provide quick, positive and trouble-free pressure interlock between the lamp socket structure and the metal or plastic housing.

Another object of this invention is to provide a lamp socket structure which does not require an irregular surface for detenting on the reflector (housing) opening for retention therein.

Another object of this invention is to provide a more simple, economical foolproof, and quick means of connecting the wire harness to the lamp socket structure by providing a structure which can easily, permanently and lockably receive individual wire harness plug terminal elements so that they cannot be accidentally dislodged from their operative use position within the lamp socket structure.

Another object of this invention is to provide a lamp socket structure which allows all of the mating terminals connecting the socket structure to the wire harness to be identical, thus greatly simplifying the harness assembly.

Yet another object of this invention is to provide a lamp socket structure wherein all internal contact members provided therein are maintained in positive wiping

3

contact with the wire plug terminals inserted into the lamp socket structure.

Yet another object of this invention is to provide a lamp socket structure wherein the bulb contact pressure is independent of external strains placed on the wire harness connected to the lamp socket structure.

Yet another object of this invention is to provide a lamp socket structure which has a built-in optic channel which provides for quick insertion, precise aiming and positive locking of the fibre optic wire.

Yet another object of this invention is to provide a lamp socket structure which has a built-in optic channel which provides one standard ferrule position for all focal lengths.

Yet another object of this invention is to provide a lamp socket structure which is easily adaptable to all focal ranges.

Yet another object of this invention is to provide a lamp socket structure which provides positive lamp filament to the reflector orientation.

Yet another object of this invention is to provide a lamp socket structure wherein there are no exposed electrical or corrosive materials.

Still another object of this invention is to provide a lamp socket structure having an internal ground assembly.

Another object of this invention is to provide a lamp socket structure being adaptable to various ranges of lamp housing wall thicknesses and material compositions.

Another object of this invention is to provide a lamp structure being equally adaptable to electrically conductive and non-conductive housing materials.

Another object of this invention is to provide a structure which inhibits the free flow of dust particles from the surroundings into the lamp housing.

Another object of this invention is to provide a lamp structure which may be economically, simply and positively sealed from moisture penetration into the lamp housing.

Another object of this invention is to provide a lamp socket structure which is designed so that assembly thereof is quickly accomplished by merely a snap-in interlock of the components thereof.

Another object of this invention is to provide a unique boot seal which cooperates the lamp socket structure to provide for positive individual wire lead sealing.

Another object of this invention is to provide a unique boot seal-lamp socket connection which is protected against accidental dislodgment.

Other objects and advantages found in the construction of the invention will be apparent from a consideration of the following specification in connection with the appended claims and the accompanying drawings.

IN THE DRAWINGS

FIG. 1 is a cross-sectional view of an embodiment of the assembled lamp socket structure having a slidably adjustable mounting collar and showing a wire harness plug terminal and bulb in place therein.

FIG. 2 is a bottom view thereof.

FIG. 3 is a top view thereof.

FIG. 4 is a cross-sectional view of an assembled lamp socket structure having a one-piece body portion.

FIG. 5 is a perspective view of another embodiment of the invention illustrating an assembled lamp socket structure.

FIG. 6 is an exploded schematic perspective view of the various components of the lamp socket structure.

FIG. 7 is a rear perspective view of the lower body housing and showing the wire harness lead terminal plug receiving sockets provided therein and further illustrating the relative positioning of the weatherproof boot seal.

FIG. 8 illustrates three different models of the invention which represent the adaptability of the lamp socket structure to different focal ranges.

FIG. 9 is a bottom view of the upper body portion of

4

the lamp socket invention showing the orienting locking shoulders and which further illustrates the detent thereon which engages the housing member.

FIG. 10 is a partial cross-sectional schematic view showing a plug terminal inserted into its lock position within the lamp socket structure and further illustrating a contact member providing for alternate grounding to metal or plastic reflector housings.

FIG. 11 is a partial cross-sectional composite view showing the capability of the compression ring seal lock arrangement to accommodate various wall thicknesses of metal or plastic housings.

FIG. 12 is a cross-sectional schematic view showing the lamp socket structure in its locked use position on a reflector housing and further illustrating the detent lock extension provided on the lamp socket structure.

FIG. 13 is a bottom view of the lamp socket structure showing the harness wire lead receiving sockets.

FIG. 14 is a sectional view of the lamp socket structure taken on line XIV—XIV of FIG. 13.

GENERAL DESCRIPTION

In general, this invention consists of a lamp socket structure which has relatively few parts and which is easy to fabricate and assemble. Further, the external configuration of the lamp socket structure insures straight-line and fool-proof orientation of the lamp socket structure with the housing panel opening during installation.

The lamp socket structure assembly is also provided with a unique resilient compression ring and detent arrangement which insures a positive pressure interlock with the housing wall and which provides against accidental dislodgment of the lamp socket structure from its operative use position on the panel housing. The compression ring cooperates with the annular shoulder of the lamp socket so as to accommodate housings constructed of various materials and having various wall thicknesses.

The overall design of the lamp socket structure provides a unit which can be quickly, easily and economically assembled by merely making a "snap-in" insertion of all components into the lamp socket housing. There are no complicated fabrication steps required to manufacture and assemble this structure.

As shown in the drawings and more specifically described hereinafter, the lamp socket structure of the instant invention is adapted to quickly, easily and lockably receive the plug terminals provided on the individual wire leads of the wire harnesses utilized in the external electrical system of the vehicle.

Thus inserted into the lamp socket structure, the plug terminals are held in positive wiping contact with the individual contact elements contained within the lamp socket structure. However, the plug terminals are not otherwise connected to the individual contact elements, thus automatically keeping such individual contacts free of pressure from external wire harness strains. In this way, bulb contact pressure is independent of external wire harness strains, thus eliminating one of the main problems encountered in the devices of the prior art.

Further as shown in FIG. 8, the unique construction embodied in the lamp socket structure permits its adaptability to provide a variety of focal ranges while maintaining the same basic internal structural features and the same internal interrelationship of its components.

A completely internal ground circuit capability is provided which enables the lamp socket structure to be used with either metal or plastic housings.

The lamp socket structure also incorporates therein a built-in fibre optic channel which is aimed at the bulb filament and which provides for quick insertion and precise aiming of the optical fibre. There is one standard ferrule position for all focal lengths.

The lamp socket structure is operated in such a manner and is so configured so that only a single reflector (hous-

ing) opening is required. No irregular surface is required on the housing for detenting.

The lamp socket structure is constructed so that there are no exposed electrical contacts, thus providing lamp socket structure which is not only safe in operation but which is not susceptible to failure due to dirt or other foreign particles finding their way into the internal portion of the structure.

Further, a unique boot seal is utilized which provides individual wire lead sealing and which cooperates with the lamp socket structure to provide a protected boot seal-lamp socket body juncture.

Thus, all of the foregoing structural features not only provide a lamp socket structure which is simple and economical to fabricate and install, but one which meets the stringent safety standards now being imposed on the automotive industry.

SPECIFIC DESCRIPTION

More specifically, the lamp socket structure 21 is shown in one of its simpler embodiments in FIG. 1 of the drawings. The lamp socket structure 21 is comprised of an upper flange collar element 22 and a main body 23. The main body housing 23 is provided with a bulb receiving cavity 24 at one end thereof which is adapted to locally receive a twist lock bulb 25 therein. A contact receiving and retaining cavity 26 is provided within the central part of the body housing 23. The contact receiving cavity 26 is in open communication with the bulb receiving cavity 24. Contact elements 27 are inserted through the bulb receiving cavity 24 into their operative use position in the contact cavity 26. Each of the contact elements 27 is provided with a resilient curved bulb contacting portion 28 at one end thereof. Further, each of the contacts 27 is provided with a reverse leaf spring extension 29 which is adapted to slidably, wipingly and springingly make contact with terminal plugs 31 inserted into the lamp socket structure. A lip extension 30 is provided within the contact cavity 26 so as to lockably retain the contacts 27 therein. Upon insertion of the contacts 27 into the contact receiving cavity 26, the leaf spring extension 29 springs outwardly behind the lip extension 30 so as to prevent accidental removal or dislodgment of the contacts 27 from the contact cavity 26.

The terminal plugs 31 are inserted into terminal plug socket cavities 32 which are provided in extension towers 33 located at the end of the body housing 23 opposite the bulb receiving cavity 24. The terminal plug socket cavities 32 are axially positioned in such a manner that terminal plugs 31 placed therein come into positive slip-proof wiping contact with the leaf spring extensions 29 of the contact elements 27. An internal shoulder 34 is provided adjacent to the terminal plug socket cavity 32 so as to engage the tang extension 35 provided on the terminal plug 31. When the terminal plug 31 is fully seated within the terminal plug socket cavity 32, the tang extension 35 springs outwardly so as to engage the internal shoulder 34, thus locking the terminal plug 31 against inadvertent removal or dislodgment from the lamp socket structure 21.

As shown in FIG. 3, a standard ground contact element 36 is provided on the lamp socket structure 21 so as to engage the base of a bulb element 25 mounted therein.

The upper ring collar element 22 is provided with an annular flange portion 37 having a circumferential seating lip extension 37a which is configured to seatably and retainably engage a resilient compression ring member 38. As will be hereinafter described, the compression ring 38 cooperates with the base of annular shoulder 39 of the ring element 22 so as to retainably engage a reflector housing wall therebetween.

The ring collar element 22 is provided with positive orienting or aligning shoulders 39 and 40 as shown in

FIG. 3, which are configured to matingly engage corresponding recesses in the opening provided through the reflector housing panel into which the lamp socket structure is mounted.

As shown in FIG. 1, a waterproof rubber boot seal 41 is selectively provided for mating engagement with the external walls of the extension towers 33 which define terminal plug socket cavities 32. The boot seal 41 is provided with an opening 42 through which the terminal plug 31 passes for insertion into the socket cavity 32. The boot seal opening 42 is normally covered by a thin wall membrane which is punctured when the terminal plug 31 is inserted therethrough. Further, the opening 42 actually stretches to accommodate the terminal plug 31, thus providing a weatherproof fit around the terminal plug 31 which prevents moisture and/or foreign particles from entering the interior of the lamp socket structure.

It should be noted that the ring element 22 can be slidably adjusted along the longitudinal axis of the main body housing 23 so that the lamp socket structure can be adapted to various focal lengths.

After ring element 22 has been properly positioned on the body housing 23 so as to achieve the desired focal range, it is then ultra-sonically joined or heat staked thereto at selected points along juncture lines 43 and/or 44.

A protective skirt 45 is provided on the body housing 23 so as to be coextensive with the extension towers 33. The skirt 45 encircles the extension towers 33 and acts to protect the boot seals 41 from damage and/or accidental dislodgment from the towers 33.

The simplest embodiment of the invention is shown in FIG. 4. The lamp socket structure shown in FIG. 4 consists of one piece plastic housing 46 having an annular flange portion 47 provided with a circumferential seating lip extension 47a. As previously discussed and as will be hereinafter discussed in greater detail, the resilient compression ring number 38 cooperates with the base of the annular shoulder 48 to retainably engage a reflector housing wall therebetween. The remaining portions of the lamp socket structure shown in FIG. 4 are identical to the embodiment of the invention shown in FIG. 1 and are therefore, numbered identically.

Another embodiment of the invention is shown in the perspective view of FIG. 5. As will be hereinafter described, an optical fibre channel 49 and ground strap cavity or channel 50 are provided within the lamp socket structure so as to eliminate any external exposure of the electrical components contained therein.

The exploded schematic view of FIG. 6 shows in detail the various components of the embodiment of the lamp socket structure shown in FIG. 5. A weatherproof boot seal assembly 51 is provided with individual boot seal units 52 having terminal plug openings 53 therethrough. Each of the individual boot seal units 52 are cylindrically configured to matingly engage the external walls of the individual terminal plug cavity socket extension towers 54. A lower body housing 55 is provided which contains contact spring cavities 56 and a ground strap cavity or channel 50 therein which are in open communication with the terminal plug cavities 57 as will be hereinafter described. The lower body housing 55 is provided with three guide retaining arms 58, 59 and 60, respectively, that are adapted to matingly engage the upper body housing 61. The lower body housing 55 is provided with an annular compression ring retaining flange 62 and circumferential lip extension 62a upon which the compression ring member 38 is seated.

Contact elements 63 and 64 are provided having curved bulb contact portions 65 and 66 at one end thereof, respectively, and leaf spring terminal plug contact portions 67 and 68 at the opposite end thereof. It should be noted that the contact elements are configured so that the tip ends 69 and 70 of the contact elements bear against the mid-portion of the contact elements. This tends to im-

7

part a more positive contact pressure against the base of the bulb inserted thereagainst.

A ground strap element 71 is provided having a curved end portion 72 which is adapted to engage the upper body housing 61. The ground strap 71 is also provided with a leaf spring extension 73 which is adapted to engage a terminal plug element 31 inserted into the terminal plug receiving cavity. The upper body housing 61 is provided with a bulb engaging cavity 74 therethrough. Suitable grooves 75 are provided within the bulb engaging cavity 74 which are adapted to lockably engage the ears 76 on the base of a standard twist lock bulb.

Orienting alignment shoulders 77, 78 and 79 are provided on the upper body housing 61. The alignment shoulders 77, 78 and 79 have different thicknesses and are configured to matingly engage corresponding recesses provided in the opening in the lamp socket reflector housing into which the lamp socket structure is mounted. This alignment or orienting feature insures that the lamp socket structure can only be inserted into the reflector housing in its proper use position. Thus, the result is fool-proof installation of the lamp socket structure into the lamp socket reflector housing.

An optical director tower 80 is provided on the upper body housing 61 which is adapted to receive an optical fibre therethrough and precisely aim it at the filament of the bulb.

The perspective schematic view of FIG. 5 clearly illustrates the assembled lamp socket structure with the twist lock bulb in its operative use position within the bulb cavity 74. The base of bulb presses against the curved portions 65 and 66 of the contact elements 63 and 64 which are positioned within the lamp socket structure, as shown. The ground strap element 71 is shown within the ground strap cavity or channel 50. Terminal plugs 31 are shown in the terminal plug socket cavities and in contact with the leaf spring extensions provided on the contact and ground strap elements.

As shown in the rear perspective view of FIG. 7, the lower body housing 55 is provided with a plurality of extension towers 54 at the base thereof. Each of the towers 54 define a terminal plug receiving socket 57 therethrough. Here again the lower body housing 55 is also provided with a protective skirt 81 which is co-extensive with the extension towers 54. In use, the skirt 81 acts as a protective guard for the towers 54 and the boot seal units 52 mounted thereover. The presence of the protective skirt 81 on the lower body housing 55 permits the installation of the lamp socket structure without any manual handling of the boot seal 51 or of the terminal wire ends leading into the sockets 57. The worker merely grasps the lower body housing 55 and the external protective skirt 81. Thus, there is very little likelihood that damage will occur to the boot seal connection or individual wire leads during the installation process.

Each of the individual boot seal units 52 has a cylindrical configuration for mating engagement with the cylindrical outer wall of the extension tower 54. As shown in FIGS. 6 and 7, the individual boot seal members 52 are joined together by ribs 82 so as to form an integral boot seal assembly 51. The boot seal assembly 51 represents a distinct improvement over the boot seal structures of the prior art. The boot seal structures of the prior art have been mounted over the entire base of the lamp socket structure. The peripheral sealing edge of the prior art boot seal structure has been located on the exposed outer wall surface of the lamp sockets, thus exposing them to damage and to failure of the sealing action. Failures of the boot seals of the prior art have exposed all of the circuits leading into the lamp socket structure. However, the boot seal assembly 51 of the instant invention provides independent peripheral sealing about each circuit by virtue of the individual boot seal units 52. The result is a more readily controllable seal joint because the sealing action is around each individual

8

wire element and not around the entire lamp socket body housing.

It should also be noted that the unique seal design requires substantially less rubber material than the relatively massive boot seals of the prior art. This brings about a significant cost reduction in the overall cost of the lamp socket structure. The design of the boot seal 51 can be varied as desired as long as it provides a water and dirt proof seal for the connection between the terminal plug elements and the lower body housing.

As shown in FIG. 8, three different models of the lamp socket structure are shown so as to illustrate the manner in which the lamp socket structure can be readily adapted to provide for different focal ranges. While the external configuration of the lower body housing 55 and upper body housing 61 vary in the different models, the internal interrelationships of the various components, channels, socket cavities and the like, remain constant. The relative positioning of the external flange 62 and of the shoulders 77, 78 and 79 on the lamp socket structure is thus changed on each model so that the position of the lamp socket structure is axially adjusted in relation to the housing panel upon which it is mounted. This provides the capability to achieve different focal ranges as desired. In essence, only the plastic tooling needs to be changed for each model; the metal tooling remains the same.

As shown in the bottom view of FIG. 9, the upper body housing 61 is provided with three longitudinally extending orienting or alignment shoulders 77, 78, 79, respectively. Shoulder 78 is provided with a detent extension 83 at the base thereof which engages a slot provided in the housing panel to lockably retain the lamp socket structure thereon. Shoulder 77 is provided with a stop should 84 at the base thereof which also cooperates with the housing panel to effect a positive seating of the lamp socket structure into its operative use position. Shoulder 79 is provided within the optical fibre channel 49 therethrough and also supports the optical director tower 80 thereon.

As shown in the partial sectional view of FIG. 10, the ground strap element 71 is positioned within the ground strap channel 50. If the housing panel is metal, the ground strap element 71 is provided with a ground extension 85 which engages the metal housing for grounding purposes.

The adaptability of the lamp socket structure to operatively engage housing panels of varying thicknesses is shown in the composite view of FIG. 11. The upper portion of the composite view of FIG. 11 illustrates engagement of the lamp socket structure with a thin housing panel 86. The compression ring 38 compresses sufficiently to permit engagement of the housing 86 between the compression ring 38 and bases of the alignment shoulders 77, 78 and 79, respectively, which are positioned on the upper body housing 61. As previously described, the compression ring 38 is seated upon the annular flange 62 of the lower body housing 55.

The lower portion of the composite view of FIG. 11 illustrates engagement of the lamp socket structure with a relatively thick housing panel 87. As shown, the compression ring 38 is merely compressed to a greater degree to accommodate the thicker housing panel 87. This capability to automatically adjust to a variety of panel housing thicknesses clearly imparts great versatility to the lamp socket structure. Thus, lamp socket structure can be mass produced without regard to individual customer requirements concerning variations in the thickness of different types of housings.

Further, the use of the compression ring 38 provides a positive and relatively vibration-free engagement of the lamp socket structure with the housing. Inasmuch as the compression ring 38 is actually compressed when the lamp socket structure lockably engages the housing, the compression ring 38 exerts a constant retentive pressure

against the back of the housing during the entire period in which the lamp socket structure is mounted in the housing. The cross-sectional schematic side view of FIG. 12 illustrates the lamp socket structure in its operative use positions on a housing 87. The detent 83 is shown in its lock position in a suitable recess provided in the housing panel 87. The compression ring 38 is shown in its compressed position between the annular flange 62 and the housing 87.

The bottom view of FIG. 13 shows the base of the lower body portion 55 of the lamp socket structure. The ground strap socket 88, the contact element sockets, 89 and 90, and the optical fibre sockets 91 receive the wire harness terminal plugs 31 which engage the ground strap, contact elements and optical fibre positioned within the lamp socket structure. The protective skirt 81 is also shown.

The cross-sectional view of FIG. 14 is taken on lines XIV—XIV of FIG. 13 and clearly shows the components of the lamp socket structure in their assembled operative use position. The upper body housing 61 has been inserted into mating engagement with the lower body housing 55. In this position the retaining arm 58, 59 and 60 are positioned intermediate the shoulders 77, 78 and 79 of the upper body housing. Once assembled in this position, the upper and lower body portions are heat-staked or ultrasonically welded to each other. The contact elements 64 and 63 (not shown) are then inserted into the lamp socket structure as previously described. The ground strap element 71 is also inserted into its respective cavity. The compression ring 38 is then mounted on the annular flange 62 and the lamp socket structure is ready for use in connection with a wire harness structure and a housing panel.

It is important to note that the lamp socket structure can be fabricated independently of the fabrication of the wire harness utilized therewith. During fabrication thereof, the wire harness is merely provided with terminal plug elements 31 at the ends of the terminal wires 92 of the wire harness (not shown). Previously, the lamp socket structures have been attached to the wire harnesses during fabrication thereof. Damage to the lamp socket structures has occurred during fabrication of the wire harnesses.

In the instant invention, the wire harness is fabricated and then the terminal plug elements 31 are inserted into the completed lamp socket structure. In this way, the wire harness structure can be quickly and easily connected to the lamp socket structure.

It is thus seen that a lamp socket structure is provided which can be easily fabricated. The unique design thereof permits quick assembly of the components into the lamp socket structure of the instant invention. Further, the use of the compression ring provides positive and relatively vibration-free engagement with housing panels of varying thicknesses. Finally, the lamp socket structure is adapted to lockably receive terminal plug elements therein and maintain the same in positive, wiping strain-free contact with the contact elements contained in the lamp socket structure.

Various other modifications of the invention may be made without departing from the principle thereof. Each of the modifications is to be considered as included in the hereinafter appended claims unless these claims by their language expressly provided otherwise. Having thus set forth the nature of our invention, we claim the following:

1. In a lamp socket structure for mounting through a mating opening provided in a thin wall housing, the combination comprising:

- (a) a unitary body housing, said body housing defining a bulb receiving cavity at one end thereof, a terminal plug receiving socket at the opposite end thereof, and a contact element receiving cavity intermediate said bulb receiving cavity and said terminal

plug receiving socket, said contact element receiving cavity being in open communication with said bulb receiving cavity and said terminal plug receiving socket, said contact element receiving cavity provided with contact element retaining means for retaining a contact element in operative engagement therein; and

- (b) at least one separate contact element freely mounted in engagement in said contact element receiving cavity, said contact element having a bulb contacting spring portion at one end thereof extending into said bulb receiving cavity and a terminal plug contacting spring portion at the opposite end thereof located within said contact element receiving cavity so as to provide simultaneous spring loaded compression contact with the base of a bulb inserted into said bulb receiving cavity and with a terminal plug element inserted into said terminal plug receiving socket, said contact element coacting with said contact element retaining means so as to prevent accidental removal thereof from said contact element receiving cavity.

2. In the lamp socket structure of claim 1 wherein said contact element is provided with a curved bulb contacting spring portion at one end thereof and leaf spring terminal plug contacting portion at the opposite end thereof.

3. In the lamp socket structure of claim 1 wherein said contact receiving cavity is provided with a contact retaining lip extension for snap engagement and retention of contact elements inserted into said contact receiving cavity.

4. In the lamp socket structure of claim 1 wherein said terminal plug receiving socket is provided with an internal shoulder, said internal shoulder adapted to make snap engagement and retention of a tang extension provided on a terminal plug inserted into said terminal plug receiving socket.

5. In the lamp socket structure of claim 1 wherein said body housing is provided with an extension tower defining said terminal plug receiving socket.

6. In a lamp socket structure for mounting through a mating opening provided in a thin wall housing, the combination comprising:

- (a) a unitary body housing, said body housing defining a bulb receiving cavity at one end thereof, a terminal plug receiving socket at the opposite end thereof, and a contact element receiving cavity intermediate said bulb receiving cavity and said terminal plug receiving socket, said contact element receiving cavity being in open communication with said bulb receiving cavity and said terminal plug receiving socket;

(b) an annular flange provided on said body housing;

(c) orienting alignment locking shoulders provided on said body housing, said locking shoulders spaced apart from said flange, said locking shoulders being proximate to the end of said housing defining said bulb cavity;

(d) at least one contact element provided in snap engagement in said contact element receiving cavity, said contact element configured to simultaneously contact the base of a bulb inserted into the bulb receiving cavity and a terminal plug element inserted into said terminal plug receiving socket; and

(e) a resilient compression ring seatably mounted on said annular flange, said compression ring adapted to pressurably retain a housing wall against said locking shoulders.

7. In the lamp socket structure of claim 6 wherein the annular flange is provided with a circumferential seating lip extension against which said compression ring is seated upon compression thereof.

8. In the lamp socket structure of claim 6 wherein one of said locking shoulders is provided with a locking

11

detent extending toward said flange, said detent adapted to engage a recess provided on the housing into which said lamp socket structure is mounted.

9. In the lamp socket structure of claim 6 wherein said contact element is provided with a curved bulb contacting portion at one end thereof and leaf spring terminal plug contacting portion at the opposite end thereof.

10. In the lamp socket structure of claim 6 wherein said contact receiving cavity is provided with a contact retaining lip extension for snap engagement and retention of contact elements inserted into said contact receiving cavity.

11. In the lamp socket structure of claim 6 wherein said terminal plug receiving socket is provided with an internal shoulder, said internal shoulder adapted to make snap engagement and retention of a tang extension provided on a terminal plug inserted into said terminal plug receiving socket.

12. In the lamp socket structure of claim 6 wherein said body housing is provided with an extension tower defining said terminal plug receiving socket.

13. In the lamp socket structure of claim 12 wherein said body housing is provided with a protective skirt co-extensive with said extension tower.

14. In the lamp socket structure of claim 12 wherein said body housing is provided with a boot seal unit in mating engagement with said extension tower, said boot seal unit defining a terminal plug opening therethrough.

15. In a lamp socket structure for mounting through a mating opening provided in a thin wall housing, the combination comprising:

(a) a main body housing, said body housing defining a bulb receiving cavity at one end thereof, a plurality of terminal plug receiving sockets at the opposite end thereof, and a contact element receiving cavity intermediate said bulb receiving cavity and said terminal plug receiving sockets, said contact element receiving cavity being in open communication with said bulb receiving cavity and said terminal plug receiving sockets;

(b) an annular ring member slidably mounted on said main body housing so as to be slidably adjustable to selectively adapt said lamp socket structure for different focal lengths, said ring member having an annular flange portion at an end thereof, said ring member having orienting alignment locking shoulders space apart from said flange portion;

(c) at least one contact element provided in snap engagement in said contact element receiving cavity, said contact element configured to simultaneously contact the base of a bulb inserted into the bulb receiving cavity and terminal plug elements inserted into said terminal plug receiving sockets; and

(d) a resilient compression ring seatably mounted on said annular flange, said compression ring adapted to pressurably retain a housing wall against said locking shoulders.

16. In the lamp socket structure of claim 15 wherein the annular flange is provided with a circumferential seating lip extension against which said compression ring is seated upon compression thereof.

17. In the lamp socket structure of claim 15 wherein one of said locking shoulders is provided with a locking detent extending toward said flange, said detent adapted to engage a recess provided on the housing into which said lamp socket structure is mounted.

18. In the lamp socket structure of claim 15 wherein said contact element is provided with a curved bulb contacting portion at one end thereof and leaf spring terminal plug contacting portion at the opposite end thereof.

19. In the lamp socket structure of claim 15 wherein said contact receiving cavity is provided with a contact retaining lip extension for snap engagement and retention of contact elements inserted into said contact receiving cavity.

12

20. In the lamp socket structure of claim 15 wherein said terminal plug receiving socket is provided with an internal shoulder, said internal shoulder adapted to make snap engagement and retention of a tang extension provided on a terminal plug inserted into said terminal plug receiving socket.

21. In the lamp socket structure of claim 15 wherein said body housing is provided with a plurality of extension towers defining said terminal plug receiving sockets.

22. In the lamp socket structure of claim 21 wherein said body housing is provided with a protective skirt co-extensive with said extension towers.

23. In the lamp socket structure of claim 21 wherein said body housing is provided with a boot seal assembly comprised of a plurality of individual boot seal units, each of said boot seal units being in mating engagement with each of said extension towers, each of said boot seal units defining a terminal plug opening therethrough.

24. In a lamp socket structure for mounting through a mating opening provided in a thin wall housing, the combination comprising:

(a) an upper body housing having a plurality of elongate orienting locking shoulders extending outwardly therefrom, said upper body housing defining a bulb receiving opening therethrough;

(b) a lower body housing having a plurality of guide retaining arms extending longitudinally therefrom so as to matingly engage said upper body housing, said lower body housing defining a bulb receiving cavity at one end thereof in open communication with said bulb receiving opening, a plurality of terminal plug receiving sockets at the opposite end thereof, and a contact element receiving cavity intermediate said bulb receiving cavity and said terminal plug receiving sockets;

(c) an annular flange provided at the end of said lower body housing proximate to said guide retaining arms, said flange being positioned closely to but spaced apart from said locking shoulders;

(d) a resilient compression ring seatably mounted on said annular flange, said compression ring adapted to pressurably retain a housing wall against said locking shoulders; and

(e) at least one contact element provided in snap engagement in said contact element receiving cavity, said contact element configured to simultaneously contact the base of a bulb inserted into the bulb receiving cavity and a terminal plug element inserted into said terminal plug receiving socket.

25. In the lamp socket structure of claim 24 wherein said upper body housing is provided with an optical fibre director tower, said optical fibre director tower adapted to receive an optional fibre therethrough and automatically aim it at the filament of a bulb inserted in said lamp socket structure.

26. In the lamp socket structure of claim 24 wherein the annular flange is provided with a circumferential seating lip extension against which said compression ring is seated upon compression thereof.

27. In the lamp socket structure of claim 24 wherein one of said locking shoulders is provided with a locking detent extending toward said flange, said detent adapted to engage a recess provided on the housing into which said lamp socket structure is mounted.

28. In the lamp socket structure of claim 24 wherein said contact element is provided with a curved bulb contacting portion at one end thereof and leaf spring terminal plug contacting portion at the opposite end thereof.

29. In the lamp socket structure of claim 24 wherein said contact receiving cavity is provided with a contact retaining lip extension for snap engagement and retention of contact elements inserted into said contact receiving cavity.

13

30. In the lamp socket structure of claim 24 wherein said terminal plug receiving socket is provided with an internal shoulder, said internal shoulder adapted to make snap engagement and retention of a tang extension provided on a terminal plug inserted into said terminal plug receiving socket.

31. In the lamp socket structure of claim 24 wherein said lower body housing is provided with a plurality of extension towers defining said terminal plug receiving sockets.

32. In the lamp socket structure of claim 31 wherein said lower body housing is provided with a protective skirt coextensive with said extension towers.

33. In the lamp socket structure of claim 31 wherein said lower body housing is provided with a boot seal assembly comprised of a plurality of individual boot seal units, each of said boot seal units being in mating engagement with each of said extension towers, each of said boot seal units defining a terminal plug opening therethrough.

34. In a lamp socket structure for mounting through a mating opening provided in a thin wall housing, the combination comprising:

(a) a unitary body housing, said body housing defining a bulb receiving cavity at one end thereof, a terminal plug receiving socket at the opposite end thereof, and a contact element receiving cavity intermediate said bulb receiving cavity and said terminal plug receiving socket, said contact element receiving cavity being in open communication with said bulb receiving cavity and said terminal plug receiving socket, said body housing being provided with an extension tower defining said terminal plug receiving socket and a protective skirt coextensive with said extension tower; and

(b) at least one contact element provided in snap engagement in said contact element receiving cavity, said contact element configured to simultaneously contact the base of a bulb inserted into the bulb receiving cavity and a terminal plug element inserted into said terminal plug receiving socket.

35. In a lamp socket structure for mounting through

14

a mating opening provided in a thin wall housing, the combination comprising:

(a) a unitary body housing, said body housing defining a bulb receiving cavity at one end thereof, a terminal plug receiving socket at the opposite end thereof, and contact element receiving cavity intermediate said bulb receiving cavity and said terminal plug receiving socket, said contact element receiving cavity being in open communication with said bulb receiving cavity and said terminal plug receiving socket, said body housing being provided with an extension tower defining said terminal plug receiving socket and a boot seal unit in mating engagement with said extension tower, said boot seal unit defining a terminal plug opening therethrough; and

(b) at least one contact element provided in snap engagement in said contact element receiving cavity, said contact element configured to simultaneously contact the base of a bulb inserted into the bulb receiving cavity and with a terminal plug element inserted into said terminal plug receiving socket.

References Cited

UNITED STATES PATENTS

2,771,590	11/1956	Nauslar	339—74 R X
3,214,722	10/1965	Weimer, Jr.	339—95 D
2,968,783	1/1961	Puety	339—59 L
2,982,939	5/1961	Kirk	339—59 L X
3,098,687	7/1963	Fitzgerald	339—217 S X
3,510,641	5/1970	Reynolds	350—96 B X

FOREIGN PATENTS

1,389,871	1/1965	France	339—176 L
-----------	--------	--------	-----------

RICHARD E. MOORE, Primary Examiner

U.S. Cl. X.R.

339—88 R, 147 R, 217 S