



(51) International Patent Classification:

G02B 13/26 (2006.01) H04N 1/028 (2006.01)
G02B 27/18 (2006.01) H04N 1/036 (2006.01)
G03B 27/54 (2006.01) G02B 3/00 (2006.01)
G03G 15/04 (2006.01) G02B 3/06 (2006.01)

(21) International Application Number:

PCT/JP2013/085017

(22) International Filing Date:

18 December 2013 (18.12.2013)

(25) Filing Language:

English

(26) Publication Language:

English

(30) Priority Data:

2012-284439 27 December 2012 (27.12.2012) JP

(71) Applicant: CANON KABUSHIKI KAISHA [JP/JP]; 30-2, Shimomaruko 3-chome, Ohta-ku, Tokyo, 1468501 (JP).

(72) Inventors: SAIGA, Takeyoshi; C/O CANON KABUSHIKI KAISHA, 30-2, Shimomaruko 3-chome, Ohta-ku, Tokyo, 1468501 (JP). TERAMURA, Masayasu; C/O CANON KABUSHIKI KAISHA, 30-2, Shimomaruko 3-chome, Ohta-ku, Tokyo, 1468501 (JP). MIYAJIMA, Yu; C/O CANON KABUSHIKI KAISHA, 30-2, Shimomaruko 3-chome, Ohta-ku, Tokyo, 1468501 (JP).

(74) Agents: ABE, Takuma et al.; C/O CANON KABUSHIKI KAISHA, 30-2, Shimomaruko 3-chome, Ohta-ku, Tokyo, 1468501 (JP).

(81) Designated States (unless otherwise indicated, for every kind of national protection available): AE, AG, AL, AM, AO, AT, AU, AZ, BA, BB, BG, BH, BN, BR, BW, BY, BZ, CA, CH, CL, CN, CO, CR, CU, CZ, DE, DK, DM, DO, DZ, EC, EE, EG, ES, FI, GB, GD, GE, GH, GM, GT, HN, HR, HU, ID, IL, IN, IR, IS, KE, KG, KN, KP, KR, KZ, LA, LC, LK, LR, LS, LT, LU, LY, MA, MD, ME, MG, MK, MN, MW, MX, MY, MZ, NA, NG, NI, NO, NZ, OM, PA, PE, PG, PH, PL, PT, QA, RO, RS, RU, RW, SA, SC, SD, SE, SG, SK, SL, SM, ST, SV, SY, TH, TJ, TM, TN, TR, TT, TZ, UA, UG, US, UZ, VC, VN, ZA, ZM, ZW.

(84) Designated States (unless otherwise indicated, for every kind of regional protection available): ARIPO (BW, GH, GM, KE, LR, LS, MW, MZ, NA, RW, SD, SL, SZ, TZ, UG, ZM, ZW), Eurasian (AM, AZ, BY, KG, KZ, RU, TJ, TM), European (AL, AT, BE, BG, CH, CY, CZ, DE, DK, EE, ES, FI, FR, GB, GR, HR, HU, IE, IS, IT, LT, LU, LV, MC, MK, MT, NL, NO, PL, PT, RO, RS, SE, SI, SK, SM, TR), OAPI (BF, BJ, CF, CG, CI, CM, GA, GN, GQ, GW, KM, ML, MR, NE, SN, TD, TG).

Published:

— with international search report (Art. 21(3))

(54) Title: OPTICAL APPARATUS, IMAGE FORMING APPARATUS, AND IMAGE READING APPARATUS

FIG. 2

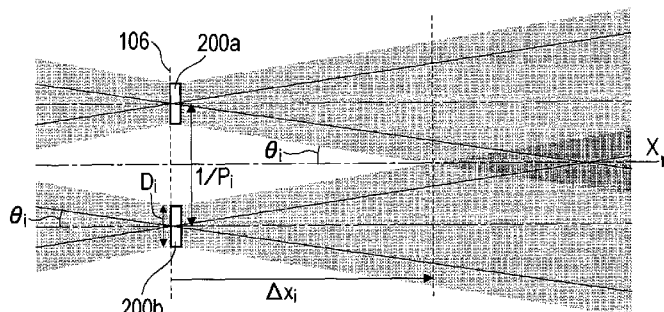

(57) Abstract: An optical apparatus includes: a light source including multiple light-emitting points arrayed in a first direction; and an imaging optical system including multiple lens optical systems arrayed in the first direction. The imaging optical system forms images of the multiple light-emitting points on a light-receiving face. In a first cross-section and in a second cross-section, half-value of a maximum value of angle of divergence of an imaging optical flux input to the light-receiving face, resolution, and a size of each image of the plurality of light-emitting points formed on the light-receiving face, satisfy predetermined conditions.



DESCRIPTION

OPTICAL APPARATUS, IMAGE FORMING APPARATUS, AND IMAGE READING APPARATUS

Technical Field

[0001] The present invention relates to an optical apparatus, and more particularly an optical apparatus suitably applied to an image forming apparatus or image reading apparatus, for example.

Background Art

[0002] As of recent, there have been developed image forming apparatuses and image reading apparatus including optical apparatuses which have a lens array made up of multiple lenses. This configuration enables realization of reduction in apparatus size and costs, in comparison with configurations scanning a photosensitive member by a polygon mirror, configurations reading images using multiple lenses and mirrors, and so forth.

[0003] PTL 1 discloses a lens array in which multiple lenses are arrayed in one direction (first direction). Each of the multiple lenses perform erecting same-size imaging of an object within a cross-section parallel to the first direction and optical axis direction (first cross-section), and perform inverted same-size imaging of an object within a

cross-section perpendicular to the first direction (second cross-section). This configuration enables the lens power to be smaller within the second cross-section, as compared with an optical system performing erecting same-size imaging in the first cross-section. This is advantageous in realizing both resolution and light available efficiency.

[0004] Now, let us consider depth of field as being indicative of imaging capabilities of the lens array, in addition to resolution. Depth of field indicates a range on the optical axis over which a predetermined resolution can be obtained in front of and behind the image field position. Normally, a lens array having a great depth of field has lower light available efficiency, and a lens array having great light available efficiency has lower depth of field. Further, a lens array has to have resolution ensured within the first and second cross-sections, so consideration has to be given to common field of depth within both cross-sections.

[0005] However, the lens array disclosed in PTL 1 does not take into consideration the common depth of field within both the first and second cross-sections when receiving input of light rays from the light-emission points of an array light source. That is to say, the lens array described in PTL 1 is of a configuration where the depth of field in the first cross-section and the depth of field in the second cross-section are different. The common depth of

field is determined by the smaller of the depths of field in both cross-sections, so the lens array according to PTL 1 has secured unnecessarily great depth of field in one cross-section. Accordingly, the lens array disclosed in PTL 1 is not an optimal configuration for realizing both resolution and light available efficiency, since light available efficiency is lost by the amount exceeding the common depth of field at one cross-section.

[0006] Also, the common depth of field of the lens array differs according to the position of each light-emitting point of the array light source, as well. Accordingly, difference in light-emitting point has to be taken into consideration to realize both resolution and light available efficiency, but there is no disclosure or suggestion of taking difference in light-emitting point with regard to the lens array described in PTL 1.

Citation List

Patent Literature

[0007] PTL 1 Japanese Patent Laid-Open No. 63-274915

Summary of Invention

[0008] It has been found desirable to provide an optical apparatus in which both light available efficiency and imaging capabilities are realized at each of the first and second cross-sections.

[0009] An optical apparatus according to an aspect of the

present invention includes: a light source including a plurality of light-emitting points arrayed in a first direction; and an imaging optical system including a plurality of lens optical systems arrayed in the first direction. The imaging optical system forms images of the plurality of light-emitting points on a light-receiving surface. Conditions of

[Math. 1]

$$0.8 \leq \frac{P_m}{P_s} \frac{1 - P_s D_s \tan \theta_m}{1 - P_m D_m \tan \theta_s} \leq 1.2$$

are satisfied, where

in a first cross-section which is parallel to the first direction and an axial direction of the lens optical systems, θ_m represents a half-value of a maximum value of angle of divergence (aperture angle) of an imaging optical flux input to the light-receiving surface, P_m represents resolution, and D_m represents a size of each image of the plurality of light-emitting points, formed on the light-receiving surface, and

in a second cross-section which is perpendicular to the first direction, θ_s represents a half-value of a maximum value of angle of divergence (aperture angle) of an imaging optical flux input to the light-receiving surface, P_s represents resolution, and D_s represents a size of each image of the plurality of light-emitting points, formed on

the light-receiving surface.

[0010] Further features of the present invention will become apparent from the following description of exemplary embodiments with reference to the attached drawings.

Brief Description of Drawings

[0011] Figs. 1A through 1C are schematic diagrams of principal portions of an optical apparatus according to a first embodiment.

[0012] Fig. 2 is a conceptual diagram for describing depth of field.

[0013] Figs. 3A through 3D are diagrams illustrating the way in which light-emitting points according to the first embodiment are imaged.

[0014] Figs. 4A and 4B are diagrams for describing how depths of field are arrayed.

[0015] Figs. 5A and 5B are diagrams illustrating depth of field properties of an imaging optical system according to the first embodiment.

[0016] Figs. 6A and 6B are diagrams illustrating depth of field properties of an imaging optical system according to a second embodiment.

[0017] Figs. 7A through 7D are diagrams illustrating the way in which light-emitting points according to a third embodiment are imaged.

[0018] Figs. 8A and 8B are diagrams illustrating depth of

field properties of an imaging optical system according to the third embodiment.

[0019] Fig. 9 is a diagram illustrating the relationship between object height and light available efficiency of a lens optical system according to the third embodiment.

[0020] Figs. 10A through 10D are diagrams illustrating the way in which light-emitting points according to a fourth embodiment are imaged.

[0021] Figs. 11A and 11B are diagrams illustrating depth of field properties of an imaging optical system according to the fourth embodiment.

[0022] Figs. 12A through 12D are diagrams illustrating the way in which light-emitting points according to a fifth embodiment are imaged.

[0023] Figs. 13A and 13B are diagrams illustrating depth of field properties of an imaging optical system according to the fifth embodiment.

[0024] Figs. 14A through 14C are schematic diagrams of principal portions of an optical apparatus according to a sixth embodiment.

[0025] Figs. 15A through 15D are diagrams illustrating the way in which light-emitting points according to the sixth embodiment are imaged.

[0026] Figs. 16A and 16B are diagrams illustrating depth of field properties of an imaging optical system according

to the sixth embodiment.

[0027] Fig. 17 is a schematic diagram of principal portions of an image forming apparatus according to an embodiment.

Description of Embodiments

[0028] Description will be made below regarding embodiments of the present invention, with reference to the drawings.

First Embodiment

[0029] Figs. 1A through 1C are schematic diagrams of principal portions of an optical apparatus according to a first embodiment applied to an image forming apparatus. Fig. 1A illustrates a first cross-section (X-Y cross-section), Fig. 1B illustrates a second cross-section (Z-X cross-section), and Fig. 1C is a frontal view from the optical axis direction (X direction). The optical apparatus according to the present embodiment includes a light source 101 including multiple light-emitting points arrayed on an object plane, and an imaging optical system 105 which condenses multiple light rays emitted from the light source 101 upon a light-receiving surface 106 (image plane).

[0030] The light source 101 includes multiple light-emitting points arrayed at equal intervals in a first direction (Y direction). LEDs, organic electroluminescence (EL) devices (elements), laser devices, or the like may be

used for the light-emitting points. A photosensitive member such as a photosensitive drum is disposed at the light-receiving surface 106. In a case where the optical apparatus is to be applied to an image reading apparatus, a document is positioned instead of the light source 101, and a photoreceptor sensor (line sensor) such as a CMOS sensor or the like is positioned at the light-receiving surface 106 instead of a photosensitive member.

[0031] The imaging optical system 105 is a lens array including imaging units 102 and 104 which include multiple lens units arrayed in the first direction, and shielding portions 103 to shield stray light rays. The imaging units 102 and 104 are configured having one row in the second direction (Z direction) of a lens row where multiple lens portions of the same shape are arrayed at equal intervals in the first direction, as illustrated in Fig. 1C. Hereinafter, the lens portions in imaging units 102 and 104 which are disposed on the same optical axis will be collectively described as lens optical system 105a.

[0032] Lens surfaces 102a, 102b, 104a, and 104b of the lens optical system 105a all have anamorphic aspheric forms (anamorphic surfaces). The shielding portions 103 serve to allow, of the light rays passing through the imaging unit 102, light rays that contribute to imaging to pass through, and shield stray light rays not contributing to imaging. In

the following description, the thickness (width in second direction) of the shielding portions 103 is excluded from consideration.

[0033] The lens portions of the imaging unit 102 condense the multiple light rays emitted from the light source 101 on an intermediate imaging plane A in the first cross-section (X-Y cross-section) parallel to the first direction and the optical axis direction of the lens optical system 105a as illustrated in Fig. 1A. Note that the intermediate imaging plane A is an imaginary plane where the imaging unit 102 forms an intermediate image of the light source 101 (object plane), i.e., performs intermediate imaging of the object plane. The intermediate imaging plane A exists at an approximately intermediate position between the light source 101 and the light-receiving surface 106 (image plane).

Light rays temporarily condensed at the intermediate imaging plane A enter each lens portion of the imaging unit 104, and further are condensed at the light-receiving surface 106.

That is to say, the imaging unit 104 forms an image of the intermediate image of the light source 101 on the light-receiving surface 106. In other words, the intermediate image is re-imaged upon the light-receiving surface 106.

[0034] Thus, the imaging optical system 105 according to the present embodiment (lens optical system 105a) is a system performing erecting same-size imaging of the light-

emitting points on the light-receiving surface 106, in the X-Y cross-section, i.e., is an erecting same-size imaging system. On the other hand, in the second cross-section (Z-X cross-section) perpendicular to the first direction, the imaging optical system 105 (lens optical system 105a) is a system performing inverted same-size imaging of the light-emitting points on the light-receiving surface 106 without performing intermediate imaging, i.e., is an inverted same-size imaging system, as illustrated in Fig. 1B. While countless light rays actually are being condensed by the imaging units 102 and 104, only a few characteristic light rays are illustrated in Fig. 1A.

[0035] Properties of the imaging optical system 105 according to the present embodiment are shown in Table 1.

[0036]

[Table 1]

Configuration			Aspheric form							
Resolution	dpi	600	Lens surface 102a		Lens surface 102b		Lens surface 104b		Lens surface 104a	
Wavelength	λ (nm)	780	R	0	R	0	R	0	R	0
Refractive index	$n(\lambda=780\text{nm})$	1.486	k	0	k	0	k	0	k	0
F-No. in first direction of lens unit	Fno_m	3.90	A20	0.50277	A20	-0.82549	A20	0.82549	A20	-0.50277
F-No. in second direction of lens unit	Fno_s	1.30	A40	-0.51259	A40	0.29164	A40	-0.29164	A40	0.51259
Power in first direction of lens unit	β m	-0.45	A60	-0.24716	A60	-0.55971	A60	0.55971	A60	0.24716
Array pitch in first direction of lens unit	p(mm)	0.77	A80	0.08357	A80	-0.01894	A80	0.01894	A80	-0.08357
Number of optical systems arrayed in first direction of lens unit	Nm(count)	291	A100	-6.91825	A100	-0.78249	A100	0.78249	A100	6.91825
Number of optical systems arrayed in second direction of lens unit	Ns(count)	1	A02	0.15643	A02	-0.19504	A02	0.19504	A02	-0.15643
Maximum object height of which lens unit can intake light	L(mm)	0.768	A22	-0.15873	A22	0.09481	A22	-0.09481	A22	0.15873
Size of light-emitting point in first direction	Dm(μ m)	42.30	A42	-0.15055	A42	-0.30023	A42	0.30023	A42	0.15055
Size of light-emitting point in second direction	Ds(μ m)	25.40	A62	5.65920	A62	3.06561	A62	-3.06561	A62	-5.65920
Aperture size			A82	-13.83601	A82	-6.53977	A82	6.53977	A82	13.83601
Aperture size in first direction of imaging unit 102	Am1(mm)	0.7	A04	-0.03679	A04	-0.00756	A04	0.00756	A04	0.03679
Aperture size in second direction of imaging unit 102	As1(mm)	2.44	A24	0.14799	A24	0.03211	A24	-0.03211	A24	-0.14799
Aperture size in first direction of imaging unit 104	Am2(mm)	0.7	A44	-1.03706	A44	-0.59005	A44	0.59005	A44	1.03706
Aperture size in second direction of imaging unit 104	As2(mm)	2.44	A64	-1.89450	A64	-0.69876	A64	0.69876	A64	1.89450
Placement			A06	0.01270	A06	0.00111	A06	-0.00111	A06	-0.01270
Distance between light source 101 and lens surface 102a	d1(mm)	2.65	A26	-0.07715	A26	-0.00101	A26	0.00101	A26	0.07715
Distance between lens surface 102a and lens surface 102b	d2(mm)	1.25	A46	0.97142	A46	0.41327	A46	-0.41327	A46	-0.97142
Distance between lens surface 102b and lens surface 104a	d3(mm)	2.16	A08	-0.00611	A08	-0.00105	A08	0.00105	A08	0.00611
Distance between lens surface 104a and lens surface 104b	d4(mm)	1.25	A28	-0.01342	A28	-0.01827	A28	0.01827	A28	0.01342
Distance between lens surface 104b and light-receiving surface 106	d5(mm)	2.65	A010	0.00128	A010	0.00010	A010	-0.00010	A010	-0.00128

[0037] If we say that the intersection with the optical

axis (X axis) at each lens portion of the imaging optical system 105 is the origin, the axis orthogonal to the optical axis in the first direction is the Y axis, and the axis orthogonal to the optical axis in the second direction is the Z axis, the aspheric form of each lens surface is expressed by the following Expression (1), where R represents the radius of curvature, k represents the conical constant, and A_{ij} ($i = 0, 1, 2, 3, 4, 5\dots, j = 0, 1, 2, 3, 4, 5\dots$) is aspheric constants.

[0038]

[Math. 2]

$$x = \frac{\frac{y^2 + z^2}{R}}{1 + \sqrt{1 - (1 + k) \left(\frac{\sqrt{y^2 + z^2}}{R} \right)^2}} + \sum_{i=0}^8 \sum_{j=0}^8 A_{ij} y^{2i} z^{2j} \quad (1)$$

[0039] A method to design the optical apparatus according to the present embodiment will be described with reference to Fig. 2.

[0040] Fig. 2 is a conceptual diagram illustrating images (200a and 200b) of two adjacent light-emitting points, formed on the light-receiving surface 106, to evaluate resolution as P_i . The interval between the two images is set to $1/P_i$. Δx_i in Fig. 2 represents the distance from the light-receiving surface 106 where the two images 200a and 200b begin to overlap due to defocusing (defocus tolerance

value), which indicates a half-value of the depth of field when the contrast is 100%. To say that "contrast is 100%" means contrast when the two images 200a and 200b do not overlap, and are completely separated (resolved).

[0041] Also, θ_i is the half-value of the angle of divergence (aperture angle) of the optical fluxes forming the images (imaging fluxes). We can see from Fig. 2 that the half-value of the angle formed between the light ray on the extreme periphery of the multiple light rays making up the imaging optical flux forming the image 200a, and the light ray on the extreme periphery of the multiple light rays making up the imaging optical flux forming the image 200b, is also θ_i . D_i is the size of the images 200a and 200b formed on the light-receiving surface 106. Note that the parameters in Fig. 2 represent a parameter within the X-Y cross-section when the suffix $i = m$, and represent a parameter within the Z-X cross-section when the suffix $i = s$.

[0042] The following relationship is derived from Fig. 2 for the parameters, such as shown in the following Expression (2).

[0043]

[Math. 3]

$$2\Delta x_i \tan \theta_i = \frac{1}{P} - D_i \quad (2)$$

[0044] Transforming Expression (2) yields the defocusing

tolerance value Δx_i when contrast is 100%, shown in the following Expression (3).

[0045]

[Math. 4]

$$\Delta x_i = \frac{1 - P_i D_i}{2P_i \tan \theta_i} \quad (3)$$

[0046] P_i and D_i are decided by the printing dot size set at the image forming apparatus (or image reading apparatus) into which the optical apparatus information has been built, and accordingly are constant for each apparatus model and each printing mode. Also, the light available efficiency of the imaging optical system 105 is proportionate to the half-value θ_i of the angle of divergence (aperture angle) of the imaging optical flux, and accordingly is approximately proportionate to $\tan \theta_i$. We can further see from Expression (3) that Δx_i is inversely proportionate to $\tan \theta_i$. Thus, we can see that light available efficiency and depth of field are in an inversely proportionate relationship.

[0047] Let us consider making the depth of field at each of the X-Y cross-section and Z-X cross-section approximately equal, in order to ensure resolution within both cross-sections and also to realize both light available efficiency and imaging capabilities. Making the depth of field at each of the X-Y cross-section and Z-X cross-section approximately equal means satisfying the following conditional Expression

(4).

[0048]

[Math. 5]

$$0.8 \leq \frac{\Delta x_s}{\Delta x_m} \leq 1.2 \quad (4)$$

[0049] Substituting Expression (3) into Expression (4) yields the following conditional Expression (5).

[0050]

[Math. 1]

$$0.8 \leq \frac{P_m}{P_s} \frac{1 - P_s D_s \tan \theta_m}{1 - P_m D_m \tan \theta_s} \leq 1.2 \quad (5)$$

[0051] The aperture size of the lens optical systems 105a in the first and second directions have been designed in the present embodiment so as to satisfy Expression (5).

Accordingly, the depth of field in both the X-Y cross-section and Z-X cross-section can be kept from becoming unnecessarily high as to the common depth of field. That is to say, an optimal optical configuration can be achieved to realize both light available efficiency and imaging capabilities (resolution) in both cross-sections.

[0052] The range of values in Expressions (4) and (5) will be described here. Normally, if change in astigmatic difference occurs due to error in placement of members of the optical apparatus, the common depth of field can drop as much as 20% or so. The effects of placement error of the

members making up the optical apparatus differ depending on whether within the X-Y cross-section or within the Z-X cross-section, so the configuration is preferably designed with this difference in mind, such that the common depth of field has some leeway.

[0053] Accordingly, the optical apparatus according to the present embodiment is configured so that the ratio between Δx_s and Δx_m is contained within a range of 0.8 to 1.2 as shown in Expressions (4) and (5), taking the effects of placement error and so forth into consideration. When the ratio between Δx_s and Δx_m falls out of the range of Expressions (4) and (5), the difference in depth of field between the X-Y cross-section and Z-X cross-section becomes great, so good imaging capability while securing light available efficiency at both cross-sections cannot be achieved. Further, if the effects of placement error can be maximally suppressed, a configuration satisfying the following Expression (6) is even more desirable.

[0054]

[Math. 6]

$$0.85 \leq \frac{P_m}{P_s} \frac{1 - P_s D_s \tan \theta_m}{1 - P_m D_m \tan \theta_s} \leq 1.15 \quad (6)$$

[0055] Next, change in the depth of field at each light-emitting point will be described. First, the behavior of each light-emitting point of the light source 101 being

imaged on the light-receiving surface 106 by the imaging optical system 105 in the X-Y cross-section will be described with reference to Figs. 3A and 3B.

[0056] Fig. 3A is a diagram illustrating the way in which a light-emitting point 101a situated on the optical axis of one lens optical system 105a (hereinafter, referred as "at axial object height") is imaged on the light-receiving surface 106 in the X-Y cross-section. Light rays emitted from the light-emitting point 101a are temporarily condensed at the intermediate imaging plane A by way of the imaging unit 102, and subsequently condensed on the light-receiving surface 106 by way of the imaging unit 104. At this time, the light rays emitted from the light-emitting point 101a each only pass through one lens portion at each of the imaging units 102 and 104. That is to say, in the X-Y cross-section, the number of lens optical systems 105a which the light rays emitted from the light-emitting point at axial object height pass through is one. Note that the half-value of the incident angle of an extreme periphery light ray 107ma of the light rays passing through that lens optical system 105a when entering the light-receiving surface 106, i.e., the half-value of the angle of divergence of the imaging optical flux of the light rays emitted from the light-emitting point 101a, is θ_{ma} of 7.32 degrees.

[0057] On the other hand, Fig. 3B is a diagram

illustrating the way in which a light-emitting point 101b of which light passes through an intermediate position between optical axes of adjacent lens optical systems 105a (hereinafter, referred as "at intermediate object height") is imaged on the light-receiving surface 106 in the X-Y cross-section. Light rays emitted from the light-emitting point 101b are temporarily condensed at the intermediate imaging plane A by way of the imaging unit 102, and subsequently condensed on the light-receiving surface 106 by way of the imaging unit 104, in the same way as with the light rays emitted from the light-emitting point 101a. At this time, the light rays emitted from the light-emitting point 101b pass through two lens portions at each of the imaging units 102 and 104. That is to say, in the X-Y cross-section the number of lens optical systems 105a which the light rays emitted from the light-emitting point at intermediate object height pass through is two. Note that the half-value of the incident angle of an extreme periphery light ray 107mb of the light rays passing through that lens optical system 105a when entering the light-receiving surface 106, i.e., the half-value of the angle of divergence of the imaging optical flux of the light rays emitted from the light-emitting point 101b, is θ_{mb} of 13.46 degrees.

[0058] Thus, the number of lens optical systems 105a which the light rays emitted from the light-emitting points pass

through in the X-Y cross-section differ according to the position of the light-emitting point, so the half-value θ_m of the angle of divergence of the imaging optical flux also changes in accordance with the position of the light-emitting point. Note that the maximum (greatest) number of lens optical systems 105a to pass through is for the imaging optical flux emitted from a light-emitting point at intermediate object height (light-emitting point 101b). That is to say, the half-value θ_m of the angle of divergence of the imaging optical flux formed by light rays from a light-emitting point at intermediate object height (light-emitting point 101b) can be deemed to be the greatest (maximum value). Accordingly, the depth of field for an imaging optical flux emitted from a light-emitting point at intermediate object height is the smallest of the light-emitting points of the light source 101.

[0059] To be precise, the half-value θ_m of the angle of divergence of the imaging optical flux from a light-emitting point at intermediate object height (light-emitting point 101b) is not the maximum. However, the half-value θ_m of the angle of divergence of the imaging optical flux is almost completely decided by the number of lens optical systems 105a through which the imaging optical flux passes, so we can view difference due to the position of light-emitting points being non-existent if the number of thereof is the

same. Accordingly, the half-value θ_m of the angle of divergence of the imaging optical flux from a light-emitting point at intermediate object height (light-emitting point 101b) is deemed to be the maximum of the multiple light-emitting points in the light source 101 in the present embodiment.

[0060] Next, the behavior of each light-emitting point of the light-emitting point 101a and light-emitting point 101b being imaged on the light-receiving surface 106 by the imaging optical system 105 in the Z-X cross-section section will be described with reference to Figs. 3C and 3D.

[0061] Light rays emitted from the light-emitting point 101a become approximately parallel light by way of the imaging unit 102, and then are input to the imaging unit 104 and condensed on the light-receiving surface 106, as illustrated in Fig. 3C. The imaging optical system 105 here is an inverted same-size imaging system in the Z-X cross-section, so the number of lens rows of the lens optical system 105a which light rays emitted from the light-emitting point 101a pass through is one. In the present embodiment, the number of lens rows in the second direction is one row, so light rays emitted from the light-emitting point 101a only pass through one lens optical system 105a. Note that the half-value of the incident angle of an extreme periphery light ray 107sa of the light rays passing through that lens

optical system 105a when entering the light-receiving surface 106, i.e., the half-value of the angle of divergence of the imaging optical flux of the light rays emitted from the light-emitting point 101a, is θ_{sa} of 21.14 degrees.

[0062] Light rays emitted from the light-emitting point 101b become approximately parallel light by way of the imaging unit 102, and then are input to the imaging unit 104 and condensed on the light-receiving surface 106, as illustrated in Fig. 3D. Accordingly, light rays emitted from the light-emitting point 101b also only pass through one lens optical system 105a, in the same way as with light rays emitted from the light-emitting point 101a. Note that the half-value of the incident angle of an extreme periphery light ray 107sb of the light rays passing through that lens optical system 105a when entering the light-receiving surface 106, i.e., the half-value of the angle of divergence of the imaging optical flux of the light rays emitted from the light-emitting point 101b, is θ_{sb} of 21.14, the same as with θ_{sa} .

[0063] Thus, the number of lens optical systems 105a which the light rays emitted from the light-emitting points pass through in the Z-X cross-section do not differ according to the position of the light-emitting point with the present embodiment, so the half-value θ_s of the angle of divergence of the imaging optical flux is constant regardless of the

position of the light-emitting point. That is to say, the depth of field is constant regardless of the position of the light-emitting point.

[0064] Thus, in the optical apparatus according to the present embodiment, the depth of field changes at each light-emitting point position in the X-Y cross-section, and the depth of field is constant regardless of the position of the light-emitting point in the Z-X cross-section.

[0065] Let us now consider whether the depth of field should be made equal (made the same) between the X-Y cross-section and Z-X cross-section at the time of any light-emitting point at the light source 101 being imaged by the imaging optical system 105, taking the difference in depth of field at each light-emitting point that has been described above.

[0066] Figs. 4A and 4B are diagrams for describing two patterns of making the depth of field the same. Figs. 4A and 4B illustrates defocusing tolerance values corresponding to each light-emitting point in the X-Y cross-section, connected by dotted lines $-\Delta x_m$ and $+\Delta x_m$, and illustrates defocusing tolerance values corresponding to each light-emitting point in the Z-X cross-section, connected by solid lines $-\Delta x_s$ and $+\Delta x_s$. That is to say, the intervals between the dotted lines $-\Delta x_m$ and $+\Delta x_m$ indicate the depth of field in the X-Y cross-section as to each light-emitting point, and

the intervals between the solid lines $-\Delta x_s$ and $+\Delta x_s$ indicate the depth of field in the Z-X cross-section as to each light-emitting point. As can be understood from Figs. 4A and 4B, the depth of field in the X-Y cross-section changes at each light-emitting point position, while the depth of field in the Z-X cross-section is constant regardless of light-emitting point position.

[0067] Fig. 4A is a pattern where the depth of field in the X-Y cross-section and the depth of field in the Z-X cross-section have been made the same at light-emitting point positions where the depth of field in the X-Y cross-section is the maximum. At this time, the common depth of field is equal to the narrowest depth of field in the X-Y cross-section, so light available efficiency is lost only regarding the difference between the common depth of field and the narrowest depth of field in the X-Y cross-section. On the other hand, Fig. 4B is a pattern where the depth of field in the X-Y cross-section and the Z-X cross-section have been made the same at light-emitting point positions where the depth of field in the X-Y cross-section is the narrowest. At this time, the common depth of field is equal to the narrowest depth of field in the X-Y cross-section and the narrowest depth of field in the Z-X cross-section, so light available efficiency is lost only regarding the difference between the common depth of field and the widest

depth of field in the X-Y cross-section.

[0068] The amount of loss in light available efficiency is the same between the two patterns illustrated in Figs. 4A and 4B. That is to say, the depth of field in the Z-X cross-section can be made narrower with the pattern illustrated in Fig. 4B, as compared to the pattern illustrated in Fig. 4A, which is advantageous regarding imaging capabilities. Accordingly, the optical apparatus according to the present embodiment is designed such that the depth of field is approximately the same in the X-Y cross-section and Z-X cross-section when the depth of field is narrowest in X-Y cross-section, i.e., when the light-emitting points at intermediate object height in the lens optical system 105a are imaged on the light-receiving surface 106.

[0069] As described above, the depth of field is smallest in the present embodiment when light-emitting points in intermediate object height are imaged on the light-receiving surface 106. At this time, the half-value θ_m of the maximum value of the angle of divergence of the imaging optical flux in the X-Y cross-section is 13.46 degrees, and the half-value θ_s of the maximum value of the angle of divergence of the imaging optical flux in the Z-X cross-section is 21.14 degrees. Also note that the imaging optical system 105 according to the present embodiment forms same-size images

of each of the light-emitting points of the light source 101 on the light-receiving surface 106, in each of the X-Y cross-section and Z-X cross-section. Thus, the image size D_m on the light-receiving surface 106 in the X-Y cross-section is $42.30 \mu\text{m}$ which is equal to the size of the light-emitting points, and the image size D_s on the light-receiving surface 106 in the Z-X cross-section is $25.40 \mu\text{m}$ which is equal to the size of the light-emitting points. Note that resolution P is evaluated as 11.81 lp/mm (equivalent to 600 dpi) in the X-Y cross-section and Z-X cross-section.

[0070] Substituting these numerical values into the middle member of conditional Expression (5) yields Expression (7), and we can see that conditional Expression (5) and Expression (6) are satisfied.

[0071]

[Math. 7]

$$\frac{P_m}{P_s} \frac{1 - P_s D_s \tan \theta_m}{1 - P_m D_m \tan \theta_s} = 0.87 \quad (7)$$

[0072] Figs. 5A and 5B are diagrams illustrating depth properties of the imaging optical system 105 according to the present embodiment in the X-Y cross-section and in the Z-X cross-section. Fig. 5A illustrates the relationship between depth of field and contrast when a light-emitting point at axial object height is imaged on the light-receiving surface 106. The depth of field in the X-Y cross-

section is greater than the depth of field in the Z-X cross-section at each contrast value. On the other hand, Fig. 5B illustrates the relationship between depth of field and contrast when a light-emitting point at intermediate object height is imaged on the light-receiving surface 106. The depth of field in the X-Y cross-section and the depth of field in the Z-X cross-section are generally the same at each contrast value.

[0073] Table 2 illustrates the depth of field for each of in the X-Y cross-section and in the Z-X cross-section for each contrast and the ratio thereof, when a light-emitting point at intermediate object height is imaged on the light-receiving surface 106.

[0074]

[Table 2]

Contrast	Δx_m	Δx_s	$\Delta x_m / \Delta x_s$
100%	0.073	0.104	1.33
90%	0.113	0.125	1.03
80%	0.137	0.144	1.00
70%	0.156	0.156	0.98
60%	0.170	0.165	0.96
50%	0.183	0.173	0.94
40%	0.196	0.181	0.93

[0075] Table 2 shows that the depth of field is approximately equal in the X-Y cross-section and in the Z-X cross-section, in the contrast range of 40 to 90%. That is to say, we can see that the depth of field in the X-Y cross-section and in the Z-X cross-section is the same when a

light-emitting point at intermediate object height is being imaged on the light-receiving surface 106. Thus it has been demonstrated that the optical apparatus according to the present embodiment realizes both light available efficiency and imaging capabilities by satisfying conditional Expression (5). The reason that the ratio of depth of field in the X-Y cross-section and in the Z-X cross-section differs from the numerical value in Expression (7) is that the numerical value in Expression (7) is a theoretical value, and in reality there is error due to influence of aberration and the like in the imaging optical system 105.

[0076] Note that as described above, conditional Expression (5) has been derived taking into consideration the depth of field when contrast is 100%, so from that perspective, confirmation should be made that the depth of field is the same (approximately equal) in both cross-sections at contrast of 100%. However, as mentioned earlier, confirming at contrast of 100% is difficult, due to aberration of the imaging optical system 105 not being taken into consideration. Accordingly, in a case of applying conditional Expression (5) to an optical apparatus, the ratio of depth of field in both cross-sections is preferably evaluated at contrast of 80 to 90%, taking into consideration the effects of aberration of the imaging optical system 105.

[0077] Also, what is demanded of actual image forming apparatuses (and image reading apparatuses) is depth of field evaluated at contrast of 40 to 80%. While conditional Expression (5) has been derived taking into consideration depth of field at contrast of 100%, this can be applied to depth of field at contrast of 40 to 80%, approximatively.

[0078] As described above, the optical apparatus according to the present embodiment can provide good imaging capability while securing light available efficiency, by making the depth of field at the time of the imaging optical system 105 imaging light-emitting points at intermediate object height on the light-receiving surface 106 to be approximately equal in the X-Y cross-section and in the Z-X cross-section.

[0079] Now, description will be made regarding a conditional expression taking into consideration the maximum number of lens optical systems 105a through which light rays from one light-emitting point of the light source 101 pass. Since the number of lens optical systems 105a through which light rays pass in the Z-X cross-section do not change with the present embodiment, we will consider only the maximum number of lens optical systems 105a through which light rays from one light-emitting point pass in the X-Y cross-section.

[0080] The maximum number of lens optical systems 105a through which light rays from one light-emitting point pass

is can be expressed by $n_m = 1 + \text{integer portion } (2 \times L/p)$, where L represents the maximum object height regarding which one lens optical system 105a can take in light rays, and p represents the array pitch of lens optical systems. In the case that n_m is an odd number, the half-value θ_m of the angle of divergence is the greatest (maximum value) when an imaging optical flux from a light-emitting point at intermediate object height is input to the light-receiving surface 106 when n_m is an even number. Accordingly, the value of the maximum half-value θ_m of the angle of divergence of the imaging optical flux changes according to the value of n_m .

[0081] Now, $\tan\theta_m$ in the X-Y cross-section described above is expressed as in the following Expression (8), by the array pitch p in the first direction of the lens optical systems 105a, the maximum value n_m of the number of lens optical systems 105a through which light rays pass, and distance l between the imaging unit 104 and light-receiving surface 106.

[0082]

[Math. 8]

$$\tan\theta_m = \frac{1}{l} \times n_m \times \frac{p}{2} = \frac{n_m p}{2l} \quad (8)$$

[0083] Also, $\tan\theta_s$ in the Z-X cross-section is expressed as in the following Expression (9), by the maximum effective

width (valid width) T of the imaging optical system 105 in the second direction, and distance l between the imaging unit 104 and light-receiving surface 106.

[0084]

[Math. 9]

$$\tan \theta_s = \frac{1}{l} \times \frac{T}{2} = \frac{T}{2l} \quad (9)$$

[0085] Now, the maximum effective width T of the imaging optical system 105 in the second direction is the maximum width of the region which imaging optical fluxes pass through at the light-emitting points in the second direction. The maximum effective width T of the imaging optical system 105 in the second direction is equal to the aperture width (aperture size) in the second direction of the lens optical systems 105a, in a configuration where only one lens row is arrayed in the second direction, as with the imaging optical system 105 according to the present embodiment.

[0086] Expression (5) can be transformed as Expression (10) by Expressions (8) and (9).

[0087]

[Math. 10]

$$0.8 \leq \frac{P_m}{P_s} \frac{1 - P_s D_s}{1 - P_m D_m} \frac{n_m p}{T} \leq 1.2 \quad (10)$$

[0088] The array pitch p , the maximum number n_m of lens optical systems 105a through which light rays from one

light-emitting point pass, and the maximum effective width T of the imaging optical system 105 in the second direction, are set with the present embodiment so as to satisfy Expression (10). Thus, the depth of field in the X-Y cross-section and in the Z-X cross-section can be made approximately equal. Further, satisfying the next Expression (11) is even more preferable, in order to suppress reduction in stability of imaging capabilities to 15%.

[0089]

[Math. 11]

$$0.85 \leq \frac{P_m}{P_s} \frac{1 - P_s D_s}{1 - P_m D_m} \frac{n_m p}{T} \leq 1.15 \quad (11)$$

[0090] The array pitch p of the lens optical systems 105a is 0.77 mm in the present embodiment, and the maximum effective width T of the imaging optical system 105 in the second direction is 2.44 mm, which is equal to the aperture size of the lens optical system 105a. Also, the maximum number n_m of lens optical systems 105a through which light rays from one light-emitting point pass is two, taking into consideration light rays from light-emitting points at intermediate object height where depth of field is minimal. The values of P_i and D_i are as described above. Substituting these values into the middle member of Expression (10) yields the following Expression (12), so it can be seen that

conditional Expressions (10) and (11) are satisfied.

[0091]

[Math. 12]

$$\frac{P_m}{P_s} \frac{1 - P_s D_s}{1 - P_m D_m} \frac{n_m P}{T} = 0.88 \quad (12)$$

[0092] The values of the middle member differ slightly between Expressions (12) and (7), but this is because Expression (8) includes approximation, and there is no difference in the fundamental idea.

[0093] As described above, the lens optical systems of the lens optical systems of the optical apparatus according to the present embodiment are designed so as to satisfy Expressions (5) or (6), or Expressions (10) or (11). Thus, the depth of field at the time of light-emitting points at intermediate object height being imaged on the light-receiving surface 106 is approximately equal in the X-Y cross-section and in the Z-X cross-section, thereby achieving good imaging capabilities while securing light available efficiency.

Second Embodiment

[0094] Next, an optical apparatus according to a second embodiment of the present invention will be described in detail. Components which are the same as or equivalent to those in the first embodiment will be denoted with the same reference numerals, and description thereof simplified or

omitted.

[0095] The present embodiment differs from the first embodiment with regard to the size of each of the light-emitting points of the light source 101, and the aperture size of the lens portion which the imaging unit 104 has, in the Z-X cross-section. Specifically, the optical apparatus according to the present embodiment is of a configuration where the size of the light-emitting points of the light source is equal in the X-Y cross-section and in the Z-X cross-section, i.e., the resolution in both cross-sections is equal, and also the aperture size A_s of the lens portion at the imaging unit 104 is changed as compared to that in the first embodiment.

[0096] At this time, the imaging optical system 105 according to the present embodiment is of a configuration to perform same-size imaging in the X-Y cross-section and in the Z-X cross-section, so the size of the image formed on the light-receiving surface 106 by light rays from each of the light-emitting points is the same in the X-Y cross-section and in the Z-X cross-section. That is to say, $D_m = D_s$ holds, and also $P_m = P_s$ holds, so the above-described conditional Expression (5) and Expression (10) are as in the following Expressions (13) and (14).

[0097]

[Math. 13]

$$0.8 \leq \frac{\tan \theta_m}{\tan \theta_s} \leq 1.2 \quad (13)$$

[0098]

[Math. 14]

$$0.8 \leq \frac{n_m p}{T} \leq 1.2 \quad (14)$$

[0099] The aperture size A_s in the second direction at the imaging units, i.e., the maximum effective width T of the imaging optical system 105 in the second direction, is 1.70 mm in the present embodiment. Accordingly, the maximum value of the maximum half-value θ_s of the angle of divergence of the imaging optical flux in the Z-X cross-section, at the time of input of light rays from light-emitting points at intermediate object height to the light-receiving surface 106, is 15.07 degrees. At this time, the other values, such as the maximum number n_m of lens optical systems 105a through which light rays from one light-emitting point pass, are unchanged from the first embodiment. Accordingly, substituting these values into the middle member of Expressions (13) and (14) yields the following Expressions (15 and 16), and it can be seen that the conditional Expressions (13) and (14) are satisfied.

[0100]

[Math. 15]

$$\frac{\tan \theta_m}{\tan \theta_s} = 0.89 \quad (15)$$

[0101]

[Math. 16]

$$\frac{n_m P}{T} = 0.91 \quad (16)$$

[0102] Figs. 6A and 6B are diagrams illustrating depth properties of the imaging optical system 105 according to the present embodiment in the X-Y cross-section and in the Z-X cross-section, in the same way as with Figs. 5A and 5B. Fig. 6A illustrates the relationship between depth of field of light rays from a light-emitting point at axial object height, and contrast, and in the same way as with Fig. 5A, the depth of field in the X-Y cross-section is greater than the depth of field in the Z-X cross-section at each contrast value. On the other hand, Fig. 6B illustrates that the depth of field in the X-Y cross-section and in the Z-X cross-section is approximately equal, due to the relationship between depth of field and contrast, with regard to light rays from a light-emitting point at intermediate object height.

[0103] Table 3 illustrates the depth of field for each of in the X-Y cross-section and in the Z-X cross-section for each contrast and the ratio thereof, when a light-emitting point at intermediate object height is imaged on the light-receiving surface 106.

[0104]

[Table 3]

Contrast	Δx_m	Δx_s	$\Delta x_m / \Delta x_s$
100%	0.086	0.105	1.16
90%	0.119	0.128	1.07
80%	0.143	0.153	1.08
70%	0.159	0.167	1.07
60%	0.171	0.181	1.09
50%	0.183	0.195	1.11
40%	0.198	0.219	1.13

[0105] Table 3 shows that the depth of field is approximately equal in the X-Y cross-section and in the Z-X cross-section, in the contrast range of 40 to 90%. Thus it has been demonstrated that the optical apparatus according to the present embodiment can make the depth of field in the X-Y cross-section and in the Z-X cross-section to be the same when a light-emitting point at intermediate object height is being imaged on the light-receiving surface 106, by being configured so as to satisfy conditional Expression (5) and conditional Expression (10).

[0106] Thus, good imaging capabilities can be achieved while securing light available efficiency with the optical apparatus according to the present embodiment, regardless of parameter values such as light-emitting point size and so forth.

Third Embodiment

[0107] Next, an optical apparatus according to a third embodiment of the present invention will be described in detail. Components which are the same as or equivalent to

those in the first embodiment will be denoted with the same reference numerals, and description thereof simplified or omitted.

[0108] The present embodiment differs from the first embodiment with regard to the values of the maximum object height L regarding which one lens optical system can take in light rays, and the array pitch p of the imaging optical system. Properties of the imaging optical system according to the present embodiment are shown in Table 4.

[0109]

[Table 4]

Configuration			Aspheric form							
Resolution	dpi	600	Lens surface 702a		Lens surface 702b		Lens surface 704b		Lens surface 704a	
Wavelength	λ (nm)	620	R	0	R	0	R	0	R	0
Refractive index	$n(\lambda=620\text{nm})$	1.534	k	0	k	0	k	0	k	0
F-No. in first direction of lens unit	Fno_m	3.90	A20	0.50277	A20	-0.82549	A20	0.82549	A20	-0.50277
F-No. in second direction of lens unit	Fno_s	1.30	A40	-0.51259	A40	0.29164	A40	-0.29164	A40	0.51259
Power in first direction of lens unit	β m	-0.45	A60	-0.24716	A60	-0.55971	A60	0.55971	A60	0.24716
Array pitch in first direction of lens unit	p(mm)	0.76	A80	0.08357	A80	-0.01894	A80	0.01894	A80	-0.08357
Number of optical systems arrayed in first direction of lens unit	Nm(count)	291	A100	-6.91825	A100	-0.78249	A100	0.78249	A100	6.91825
Number of optical systems arrayed in second direction of lens unit	Ns(count)	1	A02	0.15643	A02	-0.19504	A02	0.19504	A02	-0.15643
Maximum object height of which lens unit can intake light	L(mm)	0.873	A22	-0.15873	A22	0.09481	A22	-0.09481	A22	0.15873
size of light-emitting point in first direction	Dm(um)	42.30	A42	-0.15055	A42	-0.30023	A42	0.30023	A42	0.15055
size of light-emitting point in second direction	Ds(um)	25.40	A62	5.65920	A62	3.06561	A62	-3.06561	A62	-5.65920
Aperture size			A82	-13.83601	A82	-6.53977	A82	6.53977	A82	13.83601
Aperture size in first direction of imaging unit 702	Am1(mm)	0.76	A04	-0.03679	A04	-0.00756	A04	0.00756	A04	0.03679
Aperture size in second direction of imaging unit 702	As1(mm)	244	A24	0.14799	A24	0.03211	A24	-0.03211	A24	-0.14799
Aperture size in first direction of imaging unit 704	Am2(mm)	0.76	A44	-1.03706	A44	-0.59005	A44	0.59005	A44	1.03706
Aperture size in second direction of imaging unit 704	As2(mm)	2.44	A64	-1.89450	A64	-0.69876	A64	0.69876	A64	1.89450
Placement			A06	0.01270	A06	0.00111	A06	-0.00111	A06	-0.01270
Distance between light source 701 and lens surface 702a	d1(mm)	2.65	A26	-0.07715	A26	-0.00101	A26	0.00101	A26	0.07715
Distance between lens surface 702a and lens surface 702b	d2(mm)	1.25	A46	0.97142	A46	0.41327	A46	-0.41327	A46	-0.97142
Distance between lens surface 702b and lens surface 704a	d3(mm)	2.16	A08	-0.00611	A08	-0.00105	A08	0.00105	A08	0.00611
Distance between lens surface 704a and lens surface 704b	d4(mm)	1.25	A28	-0.01342	A28	-0.01827	A28	0.01827	A28	0.01342
Distance between lens surface 704b and light-receiving surface 706	d5(mm)	2.65	A010	0.00128	A010	0.00010	A010	-0.00010	A010	-0.00128

[0110] First, the behavior of each light-emitting point of

a light source 701 being imaged on a light-receiving surface 706 by an imaging optical system 705 in the X-Y cross-section will be described with reference to Figs. 7A and 7B.

[0111] Fig. 7A is a diagram illustrating the way in which a light-emitting point 701a at axial object height is imaged at the light-receiving surface 706 in the X-Y cross-section. Light rays emitted from the light-emitting point 701a are temporarily condensed at the intermediate imaging plane A by way of the imaging unit 702, and subsequently condensed on the light-receiving surface 706 by way of the imaging unit 704. At this time, the light rays emitted from the light-emitting point 701a passes through three lens portions at each of the imaging units 702 and 704. That is to say, the number of lens optical systems 705a which the light rays emitted from the light-emitting point at axial object height pass through is three. It can be seen from Fig. 7A that a great part of the light rays is input to the lens optical system 705a at the middle (i.e., on the axis where the light-emitting point 701a is situated), while the amount of light rays input to the two lens optical systems 705a on either side of this lens optical system 705a is scant.

[0112] On the other hand, Fig. 7B is a diagram illustrating the way in which a light-emitting point 701b at intermediate object height is imaged on the light-receiving surface 706 in the X-Y cross-section. Light rays emitted

from the light-emitting point 701b are temporarily condensed at the intermediate imaging plane A by way of the imaging unit 702, in the same way as with light rays emitted from the light-emitting point 701a, and subsequently condensed on the light-receiving surface 706 by way of the imaging unit 704. At this time, the light rays emitted from the light-emitting point 701b pass through two lens portions at each of the imaging units 702 and 704. That is to say, the number of lens optical systems 705a which the light rays emitted from the light-emitting point at intermediate object height pass through is two.

[0113] Next, the behavior of each light-emitting point of the light-emitting point 701a and light-emitting point 701b being imaged on the light-receiving surface 706 by the imaging optical system 705 in the Z-X cross-section section will be described with reference to Figs. 7C and 7D.

[0114] Light rays emitted from the light-emitting point 701a become approximately parallel light by way of the imaging unit 702, and then are input to the imaging unit 704 and condensed on the light-receiving surface 706, as illustrated in Fig. 7C. The imaging optical system 705 here is an inverted same-size imaging system in the Z-X cross-section, so the number of lens rows of the lens optical system 705a which light rays emitted from the light-emitting point 701a pass through is the number of lens rows in the

second direction. In the present embodiment, the number of lens rows in the second direction is one row, so light rays emitted from the light-emitting point 701a only pass through one lens optical system 705a. Note that the half-value of the incident angle of an extreme periphery light ray 707sa of the light rays passing through that lens optical system 705a when entering the light-receiving surface 706, i.e., the half-value of the angle of divergence of the imaging optical flux of the light rays emitted from the light-emitting point 701a, is θ_{sa} of 20.27 degrees.

[0115] Also, light rays emitted from the light-emitting point 701b become approximately parallel light by way of the imaging unit 702, and then are input to the imaging unit 704 and condensed on the light-receiving surface 706, as illustrated in Fig. 7D. Accordingly, light rays emitted from the light-emitting point 701b also only pass through one lens optical system 705a, in the same way as with light rays emitted from the light-emitting point 701a. Note that the half-value of the incident angle of an extreme periphery light ray 707sb of the light rays passing through that lens optical system 705a when entering the light-receiving surface 706, i.e., the half-value of the angle of divergence of the imaging optical flux of the light rays emitted from the light-emitting point 701b, is θ_{sb} of 20.27 degrees, the same as with θ_{sa} .

[0116] Now, let us calculate the maximum number of lens optical systems 705a through which light rays from one light-emitting point pass. In the present embodiment, the maximum object height L regarding which one lens optical system 705a can take in light rays is 0.87 mm, and the array pitch p of lens optical systems 705a is 0.76. At this time, n_m (the maximum number of lens optical systems 705a through which light rays from one light-emitting point pass in the X-Y cross-section) = 1 + integer portion ($2 \times L/p$) = 3. Note that n_m is an odd number, so the half-value θ_{ms} of the angle of divergence is the maximum (maximum value) when an imaging optical flux from a light-emitting point at intermediate object height is input to the light-receiving surface 706. Accordingly, the half-value of the incident angle of an extreme periphery light ray 707ma of the light rays passing through three lens optical systems 705a in X-Y cross-section, when entering the light-receiving surface 706, is θ_{ma} of 20.06 degrees, which is the half-value of the angle of divergence of the imaging optical flux.

[0117] On the other hand, as described above, the maximum number of lens optical systems 705a through which light rays from one light-emitting point pass in the Z-X cross-section is n_s of one, and the half-value of the angle of divergence of the imaging optical flux in X-Y cross-section, is θ_s of 20.27 degrees. Also, the aperture size A_s of the imaging

units in the second direction, i.e., the maximum effective width T of the imaging optical system 705 in the second direction is 2.44 mm.

[0118] Substituting these values into the middle member of Expressions (5) and (10) yield the following Expressions (17) and (18).

[0119]

[Math. 17]

$$\frac{P_m}{P_s} \frac{1 - P_s D_s \tan \theta_m}{1 - P_m D_m \tan \theta_s} = 1.38 \quad (17)$$

[0120]

[Math. 18]

$$\frac{P_m}{P_s} \frac{1 - P_s D_s}{1 - P_m D_m} \frac{n_m P}{T} = 1.31 \quad (18)$$

[0121] That is, it can be seen that the values of Expressions (17) and (18) do not satisfy Expressions (5) and (10).

[0122] Figs. 8A and 8B are diagrams illustrating depth properties of the imaging optical system 705 according to the present embodiment in the X-Y cross-section and in the Z-X cross-section, the same as with Figs. 5A and 5B. Fig. 5A illustrates the relationship between depth of field and contrast when a light-emitting point at axial object height is imaged on the light-receiving surface 706, and in the same way as with the case of Fig. 5A, the depth of field in

the X-Y cross-section is greater than the depth of field in the Z-X cross-section at each contrast value. On the other hand, Fig. 8B illustrates that the depth of field in the X-Y cross-section and in the Z-X cross-section are generally the same, due to the relationship between depth of field and contrast when a light-emitting point at intermediate object height is imaged on the light-receiving surface 706.

[0123] Table 5 illustrates the depth of field for each of in the X-Y cross-section and in the Z-X cross-section for each contrast and the ratio thereof, when a light-emitting point at intermediate object height is imaged on the light-receiving surface 706.

[0124]

[Table 5]

Contrast	Δx_m	Δx_s	$\Delta x_m / \Delta x_s$
100%	-	0.103	-
90%	0.105	0.120	1.12
80%	0.139	0.141	1.01
70%	0.157	0.155	0.98
60%	0.169	0.165	0.98
50%	0.181	0.174	0.98
40%	0.193	0.183	0.97

[0125] Table 5 shows that the depth of field in the X-Y cross-section and in the Z-X cross-section is made approximately equal within the range of contrast of 40 through 90%, even though the values of Expressions (17) and (18) do not satisfy the conditional Expressions (5) and (10).

[0126] The reason is that the conditional Expressions (5)

and (10) derived assuming depth of field at contrast of 100% were used by approximating as conditional expression assuming depth of field at contrast of 40 to 80%. In the first and second embodiments, the conditional Expressions (5) and (10) could be used approximatively, even in the case of evaluating at contrast of 40 to 80%. However, in a case where that approximation cannot be applied and Expressions (5) and (10) cannot be used, expressions equivalent to Expressions (5) and (10) need to be created assuming a case of performing evaluation with depth of field at contrast of 40% to 80%.

[0127] Let us consider the reason that Expressions (5) and (10) cannot be used in a case of evaluating with depth of field at contrast of 40% to 80% in the present embodiment. Light rays from axial object height pass through three lens optical systems 705a in the present embodiment. As can be seen from Fig. 7A, of the three lens optical systems 705a, light rays passing through the two lens optical systems 705a on the sides are very scant, and almost all of the light rays pass through the one lens optical system 705a at the middle. Accordingly, a $\Delta x_i'$ taking into consideration contrast of 40 to 80% (tolerance range of two adjacent light-emitting points overlapping) has to be set as to light rays passing through the lens optical systems 705a on the sides.

[0128] Fig. 9 illustrates the relation between object height as to a certain lens optical system 705a of the imaging optical system 705, and light available efficiency. As can be seen from Fig. 9, the amount of light which can be taken in increases as the object height where the light-emitting point is situated increases, and light rays cannot be taken in from an object height greater than the maximum object height L . Now, in a case of defining Δx_i assuming contrast of 100%, an object height where the light rays taken into the lens optical system 705a are scant, also has to be taken into consideration. However, in a case of defining $\Delta x_i'$ assuming contrast of 40 to 80%, the lens optical system 705a has to be deemed to not take in light rays with regard to an object height of which the amount of light is not greater than a predetermined amount.

[0129] Accordingly, an effective maximum object height (a valid maximum object height) L' at which one lens optical system 705a can take in light rays, when assuming contrast of 40 to 80%, is defined with the present embodiment. The $\Delta x_i'$ is then defined from n_i' which is the maximum effective number (valid number) of lens optical systems 705a through which light rays for the object heights at or lower than the effective maximum object height L' , and the half-value θ_i' of the effective angle (valid angle) of diversion of the imaging optical flux from each object height at or lower

than the effective maximum object height L' .

[0130] In a case of assuming contrast of 40 to 80%, the present inventor has found from experience that an effective maximum object height $L' = 0.85L$ can be defined as a general rule, when taking into consideration the light rays contributing to imaging. With the present embodiment, the object height $L' = 0.85 \times 0.87 = 0.74$ mm, so n_m' (the maximum effective number of lens optical systems 705a through which light rays from one light-emitting point pass in the X-Y cross-section) = 1 + integer portion ($2 \times 0.85 L/p$) = 2. Note that n_m' is an even number, so the half-value θ_m' of the angle of divergence is the maximum (maximum value) when an imaging optical flux from a light-emitting point at intermediate object height is input to the light-receiving surface 706. Accordingly, the half-value of the maximum value of the effective angle of divergence of the imaging optical flux in X-Y cross-section is θ_m' of 13.98 degrees.

[0131] On the other hand, as described above, the maximum effective number of lens optical systems 705a through which light rays from one light-emitting point pass in the Z-X cross-section is n_s' of one, and the half-value of the maximum effective angle of divergence of the imaging optical flux is θ_s' of 21.31 degrees. Also, the aperture size A_s of the imaging units in the second direction, i.e., the maximum effective width T of the imaging optical system 705 in the

second direction is 2.44 mm. Replacing the angle of divergence θ_i with the effective angle of divergence θ_i' , and replacing the maximum number n_m with the maximum effective number n_m' , and substituting these values into the middle member of Expression (10) yield the following Expressions (19) and (20), so we can see that condition Expressions (5) and (10) are satisfied.

[0132]

[Math. 19]

$$\frac{P_m}{P_s} \frac{1 - P_s D_s \tan \theta_m}{1 - P_m D_m \tan \theta_s} = 0.89 \quad (19)$$

[0133]

[Math. 20]

$$\frac{P_m}{P_s} \frac{1 - P_s D_s}{1 - P_m D_m} \frac{n_m p}{T} = 0.87 \quad (20)$$

[0134] Thus, with the optical apparatus according to the present embodiment, good imaging capabilities can be achieved while securing light available efficiency, by performing settings taking into consideration the effective angle of divergence θ_i' or maximum effective number n_m' , assuming contrast of 40 to 80%.

Fourth Embodiment

[0135] Next, an optical apparatus according to a fourth embodiment of the present invention will be described in detail. Components which are the same as or equivalent to

those in the first embodiment will be denoted with the same reference numerals, and description thereof simplified or omitted. The present embodiment differs from the first embodiment in that each lens optical system is an enlarging optical system in Z-X cross-section, and the light-emitting point size in Z-X cross-section and the image on the light-receiving surface are not the same size.

[0136] Figs. 10A through 10D are schematic diagrams of principal portions of an optical apparatus according to the present embodiment, with Figs. 10A and 10B illustrating the X-Y cross-section, and Figs. 10C and 10D illustrating the Z-X cross-section. The optical apparatus according to the present embodiment includes a light source 1001 including multiple light-emitting points arrayed on an object plane, and an imaging optical system 1005 which condenses multiple light rays emitted from the light source 1001 upon a light-receiving surface (image plane) 1006.

[0137] The imaging optical system 1005 is a lens array including multiple lens optical systems 1005a arrayed in the first direction, and shielding portions 1003 to shield stray light rays. The optical systems 1005a include imaging units 1002 and 1004 disposed on the same optical axis. Note that unlike the first embodiment, the lens portions making up the imaging unit 1002 and the lens portions making up the imaging unit 1004 are of different shapes. Thus, the

imaging optical system 1005 according to the present embodiment has an enlarging system in the Z-X cross-section. Lens surfaces 1002a and 1002b, of the imaging unit 1002, and 1004a and 1004b, of the imaging unit 1004 all have anamorphic aspheric forms (anamorphic surfaces). The aspheric forms thereof are expressed in Expression (1) described above.

[0138] Properties of the imaging optical system 1005 according to the present embodiment are shown in Table 6.

[0139]

[Table 6]

Configuration			Aspheric form							
Resolution	dpi	600	Lens surface 1002a		Lens surface 1002b		Lens surface 1004b		Lens surface 1004a	
Wavelength	λ (nm)	780	R	0	R	0	R	0	R	0
Refractive index	$n(\lambda=780\text{nm})$	1.486	k	0	k	0	k	0	k	0
F-No. in first direction of lens unit	Fno_m	3.90	A20	0.49353	A20	-0.84151	A20	0.84151	A20	-0.49353
F-No. in second direction of lens unit	Fno_s	1.30	A40	-0.51152	A40	0.29629	A40	-0.29629	A40	0.51152
Power in first direction of lens unit	β m	-0.45	A60	-0.58605	A60	-0.45822	A60	0.45822	A60	0.58605
Array pitch in first direction of lens unit	p (mm)	0.77	A80	0.55114	A80	-2.30492	A80	2.30492	A80	-0.55114
Number of optical systems arrayed in first direction of lens unit	Nm(count)	291	A100	-6.18001	A100	8.30369	A100	-8.30369	A100	6.18001
Number of optical systems arrayed in second direction of lens unit	Ns(count)	1	A02	0.20133	A02	-0.23125	A02	0.19949	A02	-0.03519
Maximum object height of which lens unit can intake light	L(mm)	0.768	A22	-0.25709	A22	0.010385	A22	-0.02678	A22	0.14680
size of light-emitting point in first direction	Dm(μ m)	42.30	A42	0.03333	A42	-0.41981	A42	0.22126	A42	0.28788
size of light-emitting point in second direction	Ds(μ m)	25.40	A62	5.65825	A62	3.25668	A62	-1.32747	A62	-2.40382
Aperture size			A82	-11.79314	A82	-6.03053	A82	1.49199	A82	23.62346
Aperture size in first direction of imaging unit 1002	Am1(mm)	0.7	A04	-0.02012	A04	0.00680	A04	0.00382	A04	0.01535
Aperture size in second direction of imaging unit 1002	As1(mm)	244	A24	0.16833	A24	0.01902	A24	-0.07111	A24	-0.19636
Aperture size in first direction of imaging unit 1004	Am2(mm)	0.7	A44	-0.85689	A44	-0.32633	A44	0.61214	A44	1.36064
Aperture size in second direction of imaging unit 1004	As2(mm)	2.44	A64	-2.75367	A64	-1.71326	A64	0.10789	A64	-5.64660
Placement			A06	0.01283	A06	0.00356	A06	0.00032	A06	-0.00686
Distance between light source 1001 and lens surface 1002a	d1(mm)	2.62	A26	-0.02314	A26	-0.01182	A26	-0.01030	A26	0.05265
Distance between lens surface 1002a and lens surface 1002b	d2(mm)	1.27	A46	0.69981	A46	0.41193	A46	-0.62041	A46	-2.47916
Distance between lens surface 1002b and lens surface 1004a	d3(mm)	2.16	A08	0.00714	A08	0.00306	A08	-0.00070	A08	-0.01322
Distance between lens surface 1004a and lens surface 1004b	d4(mm)	1.27	A28	-0.00717	A28	0.02039	A28	0.02811	A28	-0.01344
Distance between lens surface 1004b and light-receiving surface 1006	d5(mm)	2.62	A010	-0.00170	A010	0.00340	A010	0.00348	A010	0.02919

[0140] Fig. 10A is a diagram illustrating the way in which a light-emitting point 1001a at axial object height in the X-Y cross-section is imaged on the light-receiving surface 1006 by the imaging optical system 1005. Fig. 10B is a diagram illustrating the way in which a light-emitting point 1001b at intermediate object height in X-Y cross-section is imaged on the light-receiving surface 1006. Light rays emitted from the light-emitting points 1001a and 1001b are temporarily condensed at the intermediate imaging plane A by way of the imaging unit 1002, and subsequently condensed on the light-receiving surface 1006 by way of the imaging unit 1004.

[0141] With the present embodiment as well, the light rays emitted from the light-emitting point 1001a each only pass through one lens optical system 1005a, while the light rays emitted from the light-emitting point 1001b each pass through lens optical systems 1005a. The half-value of the angle of divergence of the light rays emitted from the light-emitting point 1001a is θ_{ma} of 7.31 degrees, and the half-value of the angle of divergence of the light rays emitted from the light-emitting point 1001b is θ_{mb} of 13.49 degrees. The half-value θ_m of the angle of divergence of the optical flux changes depending on the position of the light-emitting point in the X-Y cross-section, so the depth of field differs depending on the position of the light-

emitting point.

[0142] On the other hand, light rays emitted from the light-emitting points 1001a and 1001b become parallel light by way of the imaging unit 1002, and then are input to the imaging unit 1004 and condensed on the light-receiving surface 1006, as illustrated in Figs. 7C and 7D. The imaging optical system 1005 here is an inverted same-size imaging system in the Z-X cross-section, so the light rays emitted from each of the light-emitting points 1001a and 1001b only pass through one lens optical system 1005a. Note that the half-value of the angle of divergence of the imaging optical fluxes of the light rays emitted from the light-emitting points 1001a and 1001b, is θ_{sa} and θ_{sb} , both of 17.23 degrees. Thus, in the Z-X cross-section, the half-value θ_s is constant regardless of the position of the light-emitting points, so the half-value of the incident angle of an imaging optical flux is also constant regardless of the position of the light-emitting points.

[0143] As described above, while the depth of field of the imaging optical system 1005 in the X-Y cross-section differs depending on the position of the light-emitting points, the depth of field in the Z-X cross-section is constant regardless of the position of the light-emitting points. Accordingly, the optical apparatus according to the present embodiment is designed such that the depth of field when

light-emitting points at intermediate object height are imaged on the light-receiving surface 1006 is approximately equal in the X-Y cross-section and in the Z-X cross-section. Thus, the smallest depth of field in the X-Y cross-section and the depth of field in the Z-X cross-section can be made to be approximately equal, so imaging capabilities can be stabilized while securing maximal light.

[0144] Now, let us calculate the maximum number of lens optical systems 1005a through which light rays from one light-emitting point pass. In the present embodiment, the maximum object height L regarding which one lens optical system 105a can take in light rays is 0.768 mm, and the array pitch p of lens optical systems 7005a is 0.77 mm. At this time, n_m (the maximum number of lens optical systems 1005a through which light rays from one light-emitting point pass in the X-Y cross-section) = 1 + integer portion ($2 \times L/p$) = 2. The maximum effective number n_m' taking contrast of 40 to 80% is $n_m' = 1 + \text{integer portion } (2 \times 0.85L/p) = 2$. Also, n_m and n_m' are equal, so advantages of the present invention can be obtained with a configuration satisfying conditional Expressions (5) and (10) in both cases of taking in to consideration contrast of 100% and contrast of 40 to 80%.

[0145] In the present embodiment, n_m is an even number, so the half-value θ_m of the angle of divergence is the maximum

(maximum value) when an imaging optical flux from a light-emitting point at intermediate object height is input to the light-receiving surface 1006. Accordingly, the half-value of the maximum value of the incident angle of an imaging optical flux in X-Y cross-section is 13.49 degrees. On the other hand, as described above, the maximum number of lens optical systems 1005a through which light rays from one light-emitting point pass in the Z-X cross-section is n_s of one, and the half-value of the maximum value of the angle of divergence of the imaging optical flux, is θ_s of 17.23 degrees. Also, the aperture size A_s of the imaging units in the second direction, i.e., the maximum effective width T of the imaging optical system 1005 in the second direction is 2.44 mm.

[0146] The imaging optical system 1005 according to the present embodiment forms same-size images of each of the light-emitting points of the light source 1001 on the light-receiving surface 1006, in the X-Y cross-section and Z-X cross-section. Thus, the image size D_m on the light-receiving surface 1006 in the X-Y cross-section is 42.30 μm which is equal to the size of the light-emitting points. On the other hand, the imaging optical system 1005 performs enlarged imaging of the light-emitting points of the light source 1001 by a power of 1.3, so image size D_s on the light-receiving surface 1006 in the Z-X cross-section is

33.02 μm which 1.3 times the size of the light-emitting points (25.40 μm). In the same way as with the first embodiment, resolution P is evaluated as 11.81 lp/mm (equivalent to 600 dpi) in the X-Y cross-section and Z-X cross-section.

[0147] Substituting these numerical values into the middle member of conditional Expressions (5) and (10) yields Expressions (21) and (22), and we can see that conditional Expression (5) is satisfied but Expression (10) is not.

[0148]

[Math. 21]

$$\frac{P_m}{P_s} \frac{1 - P_s D_s \tan \theta_m}{1 - P_m D_m \tan \theta_s} = 0.94 \quad (21)$$

[0149]

[Math. 22]

$$\frac{P_m}{P_s} \frac{1 - P_s D_s}{1 - P_m D_m} \frac{n_m P}{T} = 0.77 \quad (22)$$

[0150] The reason why the present embodiment does not satisfy conditional Expression (10) is that the imaging optical system 1005 according to the present embodiment is an enlarging optical system, so approximation in Expression (8) described above does not hold. In this way, conditional Expression (10) cannot be applied unless with an optical system where (8) holds.

[0151] Figs. 11A and 11B are diagrams illustrating depth

of field properties of the imaging optical system 1005 according to the present embodiment in the X-Y cross-section and in the Z-X cross-section. Fig. 11A illustrates the relationship between depth of field and contrast when a light-emitting point at axial object height is imaged on the light-receiving surface 1006, and in the same way as with Fig. 5A, the depth of field in the X-Y cross-section is greater than the depth of field in the Z-X cross-section at each contrast value. On the other hand, Fig. 11B illustrates that the depth of field in the X-Y cross-section and in the Z-X cross-section is approximately equal, due to the relationship between depth of field and contrast, with regard to light rays from a light-emitting point at intermediate object height.

[0152] Table 7 illustrates the depth of field for each of in the X-Y cross-section and in the Z-X cross-section for each contrast and the ratio thereof, when a light-emitting point at intermediate object height is imaged on the light-receiving surface 1006.

[0153]

[Table 7]

Contrast	Δx_m	Δx_s	$\Delta x_m / \Delta x_s$
100%	0.077	0.105	1.37
90%	0.116	0.141	1.21
80%	0.142	0.161	1.13
70%	0.158	0.175	1.10
60%	0.170	0.189	1.10
50%	0.183	0.203	1.09
40%	0.196	0.217	1.10

[0154] Table 7 shows that the depth of field can be made approximately equal in the X-Y cross-section and in the Z-X cross-section, in the contrast range of 40 to 80%. Thus it has been demonstrated that the depth of field in the X-Y cross-section and in the Z-X cross-section can be made the same when a light-emitting point at intermediate object height is being imaged on the light-receiving surface 106, by configuring the optical apparatus according to the present embodiment so as to satisfy conditional Expression (5).

[0155] Thus, good imaging capabilities can be achieved while securing light available efficiency with the optical apparatus according to the present embodiment, even if an enlarging optical system.

Fifth Embodiment

[0156] Next, an optical apparatus according to a third embodiment of the present invention will be described in detail. Components which are the same as or equivalent to those in the first embodiment will be denoted with the same

reference numerals, and description thereof simplified or omitted. The present embodiment differs from the first embodiment with regard to the point that the number of lens optical systems through which optical fluxes emitted from one light-emitting point pass is greater.

[0157] Figs. 12A through 12D are schematic diagrams of principal portions of an optical apparatus according to the present embodiment, with Figs. 12A and 12B illustrating the X-Y cross-section, and Figs. 12C and 12D illustrating the Z-X cross-section. The optical apparatus according to the present embodiment includes a light source 1201 including multiple light-emitting points arrayed on an object plane, and an imaging optical system 1205 which condenses multiple light rays emitted from the light source 1201 upon a light-receiving surface (image plane) 1206.

[0158] The imaging optical system 1205 is a lens array including multiple lens optical systems 1205a arrayed in the first direction, and shielding portions 1203 to shield stray light rays. The optical systems 1205a include imaging unit 1202 and 1204 disposed on the same optical axis. In the same way as with the first embodiment, the imaging units 1202 and 1204 each have lens portions of the same form arrayed at equal intervals in the first direction at equal intervals, and the imaging units 1202 and 1204 are symmetrical with regard to the optical axis direction. Lens

surfaces 1202a and 1202b, of the imaging unit 1202, and 1204a and 1204b, of the imaging unit 1204 all have anamorphic aspheric forms (anamorphic surfaces). The aspheric forms thereof are expressed in Expression (1) described above.

[0159] Properties of the imaging optical system 1205 according to the present embodiment are shown in Table 8.

[0160]

[Table 8]

Configuration			Aspheric form							
Resolution	dpi	600	Lens surface 1202a		Lens surface 1202b		Lens surface 1204b		Lens surface 1204a	
Wavelength	λ (nm)	780	R	0	R	0	R	0	R	0
Refractive index	$n(\lambda=780\text{nm})$	1.486	k	0	k	0	k	0	k	0
F-No. in first direction of lens unit	Fno_m	6.90	A20	0.52414	A20	-1.27350	A20	1.27350	A20	-0.52414
F-No. in second direction of lens unit	Fno_s	1.31	A40	-2.34636	A40	0.73486	A40	-0.73486	A40	2.34636
Power in first direction of lens unit	β m	-0.24	A60	15.12691	A60	-4.60626	A60	4.60626	A60	-15.12691
Array pitch in first direction of lens unit	p(mm)	0.52	A80	-216.13320	A80	8.52304	A80	-8.52304	A80	216.13320
Number of optical systems arrayed in first direction of lens unit	Nm(count)	221	A100	-11.14076	A100	-19.97629	A100	19.97629	A100	11.14076
Number of optical systems arrayed in second direction of lens unit	Ns(count)	1	A02	0.14572	A02	-1.15192	A02	1.15192	A02	-0.14572
Maximum object height of which lens unit can intake light	L(mm)	1.035	A22	-0.11646	A22	0.23666	A22	-0.23666	A22	0.11646
size of light-emitting point in first direction	Dm(um)	42.30	A42	0.69251	A42	-0.73229	A42	0.73229	A42	-0.69251
size of light-emitting point in second direction	Ds(um)	25.40	A62	-0.32243	A62	2.60923	A62	-2.60923	A62	0.32243
Aperture size			A82	0.12245	A82	-6.69795	A82	6.69795	A82	-0.12245
Aperture size in first direction of imaging unit 1202	Am1(mm)	0.50	A04	-0.01460	A04	0.00082	A04	-0.00082	A04	0.01460
Aperture size in second direction of imaging unit 1202	As1(mm)	2.44	A24	0.06767	A24	-0.00507	A24	0.00507	A24	-0.06767
Aperture size in first direction of imaging unit 1204	Am2(mm)	0.50	A44	-0.23917	A44	0.02710	A44	-0.02710	A44	0.23917
Aperture size in second direction of imaging unit 1204	As2(mm)	2.44	A64	0.62105	A64	-0.09276	A64	0.09276	A64	-0.62105
Placement			A06	0.00261	A06	-0.00001	A06	0.00001	A06	-0.00001
Distance between light source 1201 and lens surface 1202a	d1(mm)	3.30	A26	-0.02011	A26	0.00010	A26	-0.00010	A26	0.02011
Distance between lens surface 1202a and lens surface 1202b	d2(mm)	0.90	A46	0.08062	A46	-0.00049	A46	0.00049	A46	-0.08062
Distance between lens surface 1202b and lens surface 1204a	d3(mm)	1.36	A08	-0.00043	A08	0.00000	A08	0.00000	A08	0.00043
Distance between lens surface 1204a and lens surface 1204b	d4(mm)	0.90	A28	0.00334	A28	0.00000	A28	0.00000	A28	-0.00334
Distance between lens surface 1204b and light-receiving surface 1206	d5(mm)	3.30	A010	0.00003	A010	0.00000	A010	0.00000	A010	-0.00003

[0161] Fig. 12A is a diagram illustrating the way in which

a light-emitting point 1201a at axial object height in the X-Y cross-section is imaged on the light-receiving surface 1206 by the imaging optical system 1205. Fig. 12B is a diagram illustrating the way in which a light-emitting point 1201b at intermediate object height in X-Y cross-section is imaged on the light-receiving surface 1206 by the imaging optical system 1205. Light rays emitted from the light-emitting points 1201a and 1201b are temporarily condensed at the intermediate imaging plane A by way of the imaging unit 1202, and subsequently condensed on the light-receiving surface 1206 by way of the imaging unit 1204.

[0162] The present embodiment differs from the first embodiment with regard to the point that the light rays emitted from the light-emitting point 1201a pass through three lens optical systems 1205a, and the light rays emitted from the light-emitting point 1201b pass through four lens optical systems 1205a. The half-value of the angle of divergence of the light rays emitted from the light-emitting point 1201a is θ_{ma} of 11.81 degrees, and the half-value of the angle of divergence of the light rays emitted from the light-emitting point 1201b is θ_{mb} of 15.59 degrees. The half-value θ_m of the angle of divergence of the optical flux changes depending on the position of the light-emitting point in the X-Y cross-section, so the depth of field differs depending on the position of the light-emitting

point.

[0163] On the other hand, in the Z-X cross-section, light rays emitted from the light-emitting points 1201a and 1201b become parallel light by way of the imaging unit 1202, and then are input to the imaging unit 1204 and condensed on the light-receiving surface 1206, as illustrated in Figs. 10C and 10D. The imaging optical system 1205 here is an inverted same-size imaging system in the Z-X cross-section, so the light rays emitted from each of the light-emitting points 1201a and 1201b only pass through one lens optical system 1205a. Note that the half-value of the angle of divergence of the imaging optical fluxes of the light rays emitted from the light-emitting points 1201a and 1201b, is θ_{sa} and θ_{sb} both of 22.47 degrees. Thus, in the Z-X cross-section, the half-value θ_s of the incident angle of an imaging optical flux is constant regardless of the position of the light-emitting points, so the depth of field is also constant regardless of the position of the light-emitting points.

[0164] As described above, while the depth of field of the imaging optical system 1205 in the X-Y cross-section differs depending on the position of the light-emitting points, the depth of field in the Z-X cross-section is constant regardless of the position of the light-emitting points. Accordingly, the optical apparatus according to the present

embodiment is designed such that the depth of field when light-emitting points at intermediate object height are imaged on the light-receiving surface 1206 is approximately equal in the X-Y cross-section and in the Z-X cross-section. Thus, the smallest depth of field in the X-Y cross-section and the depth of field in the Z-X cross-section can be made to be approximately equal, so imaging capabilities can be stabilized while securing maximal light.

[0165] Now, let us calculate the maximum number of lens optical systems 1205a through which light rays from one light-emitting point pass. In the present embodiment, the maximum object height L regarding which one lens optical system 105a can take in light rays is 1.035 mm, and the array pitch p of lens optical systems 1205a is 0.52.

Accordingly, n_m (the maximum number of lens optical systems 1205a through which light rays from one light-emitting point pass in the X-Y cross-section) = 1 + integer portion ($2 \times L/p$) = 4. Also, the maximum number n_m' assuming contrast of 40 to 80% = 1 + integer portion ($2 \times 0.85L/p$) = 4. Since n_m and n_m' are equal, advantages of the present invention can be obtained with a configuration satisfying conditional Expressions (5) and (10) in both cases of taking into consideration contrast of 100% and contrast of 40 to 80%.

[0166] In the present embodiment, n_m is an even number, so the half-value θ_m of the angle of divergence is the maximum

(maximum value) when an imaging optical flux from a light-emitting point at intermediate object height is input to the light-receiving surface 1206. At this time, the half-value of the maximum value of the incident angle of an imaging optical flux in X-Y cross-section is 15.59 degrees. On the other hand, as described above, the maximum number of lens optical systems 1205a through which light rays from one light-emitting point pass in the X-Y cross-section is n_s of one, and the half-value of the angle of divergence of the imaging optical flux, is θ_s of 22.47 degrees. Also, the aperture size A_s of the imaging units in the second direction, i.e., the maximum effective width T of the imaging optical system 1205 in the second direction is 2.44 mm.

[0167] The imaging optical system 1205 according to the present embodiment forms same-size images of each of the light-emitting points of the light source 1201 on the light-receiving surface 1206, in each of the X-Y cross-section and Z-X cross-section. Thus, the image size D_m on the light-receiving surface 1206 in the X-Y cross-section is 42.30 μm which is equal to the size of the light-emitting points. The image size D_s on the light-receiving surface 1206 in the Z-X cross-section is the same 25.40 μm . In the same way as with the first embodiment, resolution P is evaluated as 11.81 lp/mm (equivalent to 600 dpi) in the X-Y cross-section

and Z-X cross-section.

[0168] Substituting these numerical values into the middle member of conditional Expressions (5) and (10) yields Expressions (23) and (24), and we can see that conditional Expressions (5) and (10) are satisfied.

[0169]

[Math. 23]

$$\frac{P_m}{P_s} \frac{1 - P_s D_s \tan \theta_m}{1 - P_m D_m \tan \theta_s} = 0.94 \quad (23)$$

[0170]

[Math. 24]

$$\frac{P_m}{P_s} \frac{1 - P_s D_s}{1 - P_m D_m} \frac{n_m p}{T} = 1.19 \quad (24)$$

[0171] Figs. 13A and 13B are diagrams illustrating depth properties of the imaging optical system 1205 according to the present embodiment in the X-Y cross-section and in the Z-X cross-section, in the same way as with the first embodiment. Fig. 13A illustrates the relationship between depth of field and contrast when a light-emitting point at axial object height is imaged on the light-receiving surface 1206, and in the same way as with Fig. 5A, the depth of field in the X-Y cross-section is greater than the depth of field in the Z-X cross-section at each contrast value. On the other hand, Fig. 13B illustrates that the depth of field in the X-Y cross-section and in the Z-X cross-section is

approximately equal, due to the relationship between depth of field and contrast, when a light-emitting point at intermediate object height is imaged on the light-receiving surface 1206.

[0172] Table 9 illustrates the depth of field for each of in the X-Y cross-section and in the Z-X cross-section for each contrast and the ratio thereof, when a light-emitting point at intermediate object height is imaged on the light-receiving surface 1206.

[0173]

[Table 9]

Contrast	Δx_m	Δx_s	$\Delta x_m / \Delta x_s$
100%	0.060	0.086	1.46
90%	0.134	0.127	0.96
80%	0.167	0.141	0.85
70%	0.190	0.156	0.82
60%	0.212	0.170	0.79
50%	0.232	0.183	0.77
40%	0.257	0.196	0.74

[0174] Table 9 shows that the depth of field can be made approximately equal in the X-Y cross-section and in the Z-X cross-section, in the contrast range of 40 to 90%. Thus it has been demonstrated that the depth of field in the X-Y cross-section and in the Z-X cross-section can be made the same when a light-emitting point at intermediate object height is being imaged on the light-receiving surface 1206, by configuring the optical apparatus according to the present embodiment so as to satisfy conditional Expressions

(5) and (10). Thus, good imaging capabilities can be achieved while securing light available efficiency with the optical apparatus according to the present embodiment, even if the number of lens optical systems through which light rays from each light-emitting point pass, increases.

[0175] Note that the power in the X-Y cross-section of each lens optical system has to be increased in accordance with increase in the number of lens optical systems through which light rays from one light-emitting point pass with the present embodiment, but increased power also increases aberration, which is undesirable. Accordingly, n_m and n_m' are preferably four or less, taking into consideration the imaging capabilities of the lens optical system.

Sixth Embodiment

[0176] Next, an optical apparatus according to a third embodiment of the present invention will be described in detail. Components which are the same as or equivalent to those in the first embodiment will be denoted with the same reference numerals, and description thereof simplified or omitted. The present embodiment is a configuration where the lens optical systems according to the first embodiment have been divided into top and bottom, and one thereof shifted in the first direction by half-pitch of the lens optical systems.

[0177] Figs. 14A through 14C are schematic diagrams of

principal portions of an optical apparatus according to the present embodiment. Fig. 14A illustrates the X-Y cross-section, Fig. 14B illustrates the Z-X cross-section, and Fig. 14C is a frontal view from the X direction. The optical apparatus according to the present embodiment includes a light source 1401 including multiple light-emitting points arrayed on an object plane, and an imaging optical system 1405 which condenses multiple light rays emitted from the light source 1401 upon a light-receiving surface 1406.

[0178] The imaging optical system 1405 is a lens array including multiple lens optical systems 1405a arrayed in the first direction, and shielding portions 1403 to shield stray light rays. The lens optical systems 1405a include imaging units 1402 and 1404 situated on the same optical axis. Unlike the first embodiment, the imaging units 1402 and 1404 each include two lens rows in the second direction. Each lens row is configured of multiple lens portions of the same shape being arrayed in the first direction at equal intervals. The two lens rows making up each of the imaging units 1402 and 1404 are configured such that the lens row making up each imaging unit in the first embodiment is divided top and bottom and shifted in the first direction by a half-pitch of the lens unit array interval. The imaging unit 1402 and imaging unit 1404 are situated symmetrically as to the optical axis direction.

[0179] Lens surfaces 1402a through 1402d of the imaging unit 1402 and lens surfaces 1404a through 1404d of the imaging unit 1404 each have anamorphic aspheric forms (anamorphic surfaces). The aspheric forms thereof are expressed in Expression (1) described above.

[0180] Properties of the imaging optical system 1405 according to the present embodiment are shown in Table 10.

[0181]

[Table 10]

Configuration			Aspheric form							
Resolution	dpi	600	Lens surface 1402a, 1402c		Lens surface 1402b, 1402d		Lens surface 1404b, 1404d		Lens surface 1404a, 1404c	
Wavelength	λ (nm)	780	R	0	R	0	R	0	R	0
Refractive index	$n(\lambda=780\text{nm})$	1.486	k	0	k	0	k	0	k	0
F-No. in first direction of lens unit	Fno_m	3.90	A20	0.50277	A20	-0.82549	A20	0.82549	A20	-0.50277
F-No. in second direction of lens unit	Fno_s	1.30	A40	-0.51259	A40	0.29164	A40	-0.29164	A40	0.51259
Power in first direction of lens unit	β m	-0.45	A60	-0.24716	A60	-0.55971	A60	0.55971	A60	0.24716
Array pitch in first direction of lens unit	p(mm)	0.77	A80	0.08357	A80	-0.01894	A80	0.01894	A80	-0.08357
Number of optical systems arrayed in first direction of lens unit	Nm(count)	291	A100	-6.91825	A100	-0.78249	A100	0.78249	A100	6.91825
Number of optical systems arrayed in second direction of lens unit	Ns(count)	1	A02	0.15643	A02	-0.19504	A02	0.19504	A02	-0.15643
Maximum object height of which lens unit can intake light	L(mm)	0.768	A22	-0.15873	A22	0.09481	A22	-0.09481	A22	0.15873
size of light-emitting point in first direction	Dm(μ m)	42.30	A42	-0.15055	A42	-0.30023	A42	0.30023	A42	0.15055
size of light-emitting point in second direction	Ds(μ m)	25.40	A62	5.65920	A62	3.06561	A62	-3.06561	A62	-5.65920
Aperture size			A82	-13.83601	A82	-6.53977	A82	6.53977	A82	13.83601
Aperture size in first direction of imaging unit 1402	Am1(mm)	0.7	A04	-0.03679	A04	-0.00756	A04	0.00756	A04	0.03679
Aperture size in second direction of imaging unit 1402	As1(mm)	1.22	A24	0.14799	A24	0.03211	A24	-0.03211	A24	-0.14799
Aperture size in first direction of imaging unit 1404	Am2(mm)	0.7	A44	-1.03706	A44	-0.59005	A44	0.59005	A44	1.03706
Aperture size in second direction of imaging unit 1404	As2(mm)	1.22	A64	-1.89450	A64	-0.69876	A64	0.69876	A64	1.89450
Placement			A06	0.01270	A06	0.00111	A06	-0.00111	A06	-0.01270
Distance between light source 1401 and lens surface 1402a	d1(mm)	2.65	A26	-0.07715	A26	-0.00101	A26	0.00101	A26	0.07715
Distance between lens surface 1402a and lens surface 1402b	d2(mm)	1.25	A46	0.97142	A46	0.41327	A46	-0.41327	A46	-0.97142
Distance between lens surface 1402b and lens surface 1404a	d3(mm)	2.16	A08	-0.00611	A08	-0.00105	A08	0.00105	A08	0.00611
Distance between lens surface 1404a and lens surface 1404b	d4(mm)	1.25	A28	-0.01342	A28	-0.01827	A28	0.01827	A28	0.01342
Distance between lens surface 1404b and light-receiving surface 1406	d5(mm)	2.65	A010	0.00128	A010	0.00010	A010	-0.00010	A010	-0.00128

[0182] Fig. 15A is a diagram illustrating the way in which a light-emitting point 1401a at axial object height in the X-Y cross-section is imaged on the light-receiving surface

1406 by the imaging optical system 1405. Fig. 15B is a diagram illustrating the way in which a light-emitting point 1401b at intermediate object height in Z-X in X-Y cross-section is imaged on the light-receiving surface 1406.

[0183] Now, the present embodiment differs from the other embodiments described above with regard to the positions of the light-emitting points 1401b at intermediate object height. Specifically, the light-emitting points 1401b are not situated at intermediate positions between optical axes of lens optical systems 1405a adjacent in the first direction (Y direction), but are situated at intermediate positions between optical axes of lens optical systems 1405a adjacent in the second direction (Z direction). This is because the lens optical systems 1405a have a configuration of being divided top and bottom and shifted by half-pitch.

[0184] Light rays emitted from each of the light-emitting points 1401a and 1401b are temporarily condensed at the intermediate imaging plane A by way of the imaging unit 1402, and subsequently condensed on the light-receiving surface 1406 by way of the imaging unit 1404. The half-values of the angles of divergence of the light rays emitted from the light-emitting points 1401a and 1401b in the X-Y cross-section are θ_{ma} and θ_{mb} of 7.32 degrees and 13.38 degrees, respectively.

[0185] On the other hand, light rays emitted from the

light-emitting points 1401a and 1401b in the Z-X cross-section become approximately parallel light by way of the imaging unit 1402, and then are input to the imaging unit 1404 and condensed on the light-receiving surface 1406, as illustrated in Figs. 15C and 15D. The half-value of the angle of divergence of the imaging optical fluxes of the light rays emitted from the light-emitting points 1401a and 1401b, is θ_{sa} and θ_{sb} both of 21.14 degrees. Thus, in the Z-X cross-section, the half-value θ_s is constant regardless of the position of the light-emitting points, so the depth of field is also constant regardless of the position of the light-emitting points.

[0186] As described above, while the depth of field of the imaging optical system 1405 in the X-Y cross-section differs depending on the position of the light-emitting points, the depth of field in the Z-X cross-section is constant regardless of the position of the light-emitting points. Accordingly, the optical apparatus according to the present embodiment is designed such that the depth of field when light-emitting points at intermediate object height are imaged on the light-receiving surface 1406 is approximately equal in the X-Y cross-section and in the Z-X cross-section. Thus, the smallest depth of field in the X-Y cross-section and the depth of field in the Z-X cross-section can be made to be approximately equal, so imaging capabilities can be

stabilized while securing maximal light.

[0187] Now, let us calculate the maximum number of lens optical systems 1405a through which light rays from one light-emitting point pass. In a case where Expression (10) is to be applied to a configuration where multiple lens rows are arrayed in the second direction as with the present embodiment, lens rows where light rays on the extreme periphery are input have to be taken into consideration. Accordingly, n_m , which is the maximum number of lens optical systems 1405a through which light rays from one light-emitting point pass in the X-Y cross-section, and the aperture size A_m of the lens optical system 1405a in the first direction, are taken into consideration. Specifically, we will consider application of Expression (10) to a lens row where the value of $n_m \times A_m$ is maximum.

[0188] In the present embodiment, the maximum object height L regarding which one lens optical system 105a can take in light rays is 0.768 mm, and the array pitch p of lens optical systems 1405a is 0.77 mm. At this time, n_m (the maximum number of lens optical systems 705a through which light rays from one light-emitting point pass in the X-Y cross-section) = 1 + integer portion ($2 \times L/p$) = 2. Also, the maximum effective number n_m' taking contrast of 40 to 80% is $n_m' = 1 + \text{integer portion } (2 \times 0.85L/p) = 2$. Further, the aperture size A_m in the first direction is 0.7 mm for

both upper and lower lens optical systems 1405a, so $n_m \times A_m = 1.4$ mm holds. The value of $n_m \times A_m$ is equal for the upper and lower lens optical systems 1405a in the present embodiment, so advantages of the present invention can be obtained with a configuration satisfying conditional Expressions (5) and (10) at either row. Also, n_m and n_m' are equal, so advantages of the present invention can be obtained with a configuration satisfying conditional Expressions (5) and (10) in both cases of taking into consideration contrast of 100% and contrast of 40 to 80%.

[0189] In the present embodiment, n_m is an even number, so the half-value θ_{ms} of the angle of divergence is the maximum (maximum value) when an imaging optical flux from a light-emitting point at intermediate object height is input to the light-receiving surface 1406. At this time, the half-value of the maximum value of the incident angle of an imaging optical flux in X-Y cross-section is 13.38 degrees. On the other hand, as described above, the maximum number of lens optical systems 1405a through which light rays from one light-emitting point pass in the Z-X cross-section is n_s of two, and the half-value of the angle of divergence of the imaging optical flux, is θ_s of 21.14 degrees. Also, the aperture size A_s of the lens optical systems 1405a for the upper and lower lens rows is 1.22 mm, so the maximum effective width T of the imaging optical system 1405 in the

second direction is 2.44 mm.

[0190] The imaging optical system 1405 according to the present embodiment forms same-size images of each of the light-emitting points of the light source 1401 on the light-receiving surface 1406, in each of the X-Y cross-section and Z-X cross-section. Thus, the image size D_m on the light-receiving surface 1406 in the X-Y cross-section is $42.30 \mu\text{m}$ which is equal to the size of the light-emitting points, and the image size D_s on the light-receiving surface 1406 in the Z-X cross-section is $25.40 \mu\text{m}$ which is equal to the size of the light-emitting points. In the same way as with the first embodiment, resolution P is evaluated as 11.81 lp/mm (equivalent to 600 dpi) in the X-Y cross-section and Z-X cross-section.

[0191] Substituting these numerical values into the middle member of conditional Expressions (5) and (10) yields the following Expressions (25) and (26), and we can see that conditional Expressions (5) and (10) are satisfied.

[0192]

[Math. 25]

$$\frac{P_m}{P_s} \frac{1 - P_s D_s \tan \theta_m}{1 - P_m D_m \tan \theta_s} = 0.86 \quad (25)$$

[0193]

[Math. 12]

$$\frac{P_m}{P_s} \frac{1 - P_s D_s}{1 - P_m D_m} \frac{n_m P}{T} = 0.88 \quad (26)$$

[0194] Figs. 16A and 16B are diagrams illustrating depth properties of the imaging optical system 1405 according to the present embodiment in the X-Y cross-section and in the Z-X cross-section, in the same way as with the first embodiment. Fig. 16A illustrates the relationship between depth of field and contrast when a light-emitting point at axial object height is imaged on the light-receiving surface 1406. Also, Fig. 16B illustrates the relationship between depth of field and contrast when a light-emitting point at intermediate object height of each lens optical system 1405a is imaged on the light-receiving surface 1406. Fig. 16B illustrates that the depth of field in the X-Y cross-section and in the Z-X cross-section is approximately equal.

[0195] Table 11 illustrates the depth of field for each of in the X-Y cross-section and in the Z-X cross-section for each contrast and the ratio thereof, when a light-emitting point at intermediate object height is imaged on the light-receiving surface 1406.

[0196]

[Table 11]

Contrast	Δx_m	Δx_s	$\Delta x_m / \Delta x_s$
100%	0.089	0.104	1.09
90%	0.139	0.125	0.84
80%	0.166	0.144	0.82
70%	0.186	0.156	0.82
60%	0.207	0.165	0.79
50%	0.226	0.173	0.76
40%	0.245	0.181	0.74

[0197] Table 11 shows that the depth of field can be made approximately equal in the X-Y cross-section and in the Z-X cross-section, in the contrast range of 70 to 100%. Thus it has been demonstrated that the depth of field in the X-Y cross-section and in the Z-X cross-section can be made the same when a light-emitting point at intermediate object height is being imaged on the light-receiving surface 1406, by configuring the optical apparatus according to the present embodiment so as to satisfy conditional Expressions (5) and (10).

[0198] Thus, good imaging capabilities can be achieved while securing light available efficiency with the optical apparatus according to the present embodiment, even with a configuration where a lens row is divided top and bottom.

Image Forming Apparatus

[0199] Fig. 17 is a schematic diagram (Z-X cross-sectional view) of principal portions of a color image forming apparatus 33 according to an embodiment of the present invention. The color image forming apparatus 33 is a tandem-type color image forming apparatus, which has four of any one of the optical apparatuses (exposure units) illustrated in the embodiments described above, each exposing the light-receiving surface (photosensitive surface) of photosensitive drums in conjunction. The color image forming apparatus 33 includes optical apparatuses 17,

18, 19, and 20, having one of the configurations illustrated in the embodiments, photosensitive drums 21, 22, 23, and 24, serving as image carrying members, developing units 25, 26, 27, and 28, a conveying belt 34, and a fixing unit 37. The optical apparatuses 17, 18, 19, and 20 are each disposed such that the second direction of the imaging optical systems matches the sub-scanning direction (Z direction) of the photosensitive drums 21, 22, 23, and 24, which is the direction of rotation thereof.

[0200] In Fig. 17, the color image forming apparatus 33 receives input of color signals of R (red), G (green), and B (blue), from external equipment 35 such as a personal computer or the like. These color signals are converted into image signals (dot data) of C (cyan), M (magenta), Y (yellow), and K (black) by a printer controller 36 within the apparatus, and input to the respective optical apparatuses 17, 18, 19, and 20. The printer controller 36 controls each part of the color image forming apparatus 33, besides signal conversion.

[0201] Exposure lights 29, 30, 31, 32 modulated in accordance with the color image signals is emitted from the optical apparatuses 17, 18, 19, and 20, respectively. The exposure lights 29, 30, 31, 32 expose the photosensitive surfaces of the photosensitive drums 21, 22, 23, and 24 charged by charging rollers omitted from illustration,

forming electrostatic latent images on the photosensitive surfaces of each. Subsequently, the electrostatic latent images on the photosensitive surfaces of the photosensitive drums 21, 22, 23, and 24 developed by respective developing units 25, 26, 27, and 28, as toner images. The toner images of each color are transferred by overlaying onto a transfer medium, by a transferring unit omitted from illustration, and then fixed by the fixing unit, thereby completing one fill-color image.

Image Reading Apparatus

[0202] Optical apparatuses having a configuration according to any of the embodiments described above may be used in an image reading apparatus. In this case an optical apparatus is configured by a document being positioned at the object face of the imaging optical system, and a photoreceptor unit being positioned at the image plane (light-receiving surface). A line sensor configured of a CCD sensor or CMOS sensor or the like, for example, may be used as the photoreceptor unit. Also, a color digital photocopier may be configured by connecting the image reading apparatus as the above-described external equipment 35, to the color image forming apparatus 33.

[0203] An image reading apparatus can irradiate a document by an illumination unit including a light source, condense optical fluxes (reflected light or transmitted light) on an

imaging optical system, and receive light by a sensor face of the photoreceptor unit. At this time, the imaging optical system is positioned such that the second direction thereof matches the direction in which the relative position between the document and the imaging optical system is changed (sub-scanning direction), whereby the document can be sequentially read in the sub-scanning direction.

[0204] Note that the illumination unit in the image reading apparatus is not restricted to a light source, an a configuration may be used where external light is guided to the original. Here, the image on the original at the light-receiving surface of the photoreceptor unit which the image reading device has can be conceived as being made up of infinitely small dots. Accordingly, in a case of applying the above-described Expressions (5) and (10) to an optical apparatus relating to an image reading apparatus, $D_i = 0$ can be set and transformation made as with the following Expressions (27) and (28).

[0205]

[Math. 26]

$$0.8 \leq \frac{P_m \tan \theta_m}{P_s \tan \theta_s} \leq 1.2 \quad (27)$$

[0206]

[Math. 27]

$$0.8 \leq \frac{P_m n_m P}{P_s T} \leq 1.2 \quad (28)$$

Modifications

[0207] While the present invention has been described with reference to exemplary embodiments, it is to be understood that the invention is not limited to the disclosed exemplary embodiments. The scope of the following claims is to be accorded the broadest interpretation so as to encompass all such modifications and equivalent structures and functions.

[0208] For example, the embodiments have been described above as configurations where Expression (5) is satisfied by innovating the designed aperture size of the lens portions in the first direction and second direction, but design methods for the optical apparatus to satisfy Expression (5) are not restricted to this. For example, a configuration may be employed where innovation is made regarding size of the light-emitting points of the light source in the first direction and second direction to satisfy Expression (5).

[0209] Also, the lens surfaces of the imaging optical system in the embodiments have aspheric forms expressed by Expression (1), but the present invention is not restricted to this, and aspheric forms expressed by other expressions may be employed. Also, while light-emitting points are imaged inverted on the light-receiving surface without intermediate imaging in the Z-X cross-section, the light-emitting points may be imaged erect on the light-receiving surface after intermediate imaging, as with the X-Y cross-

section.

[0210] Further, configurations where two rows of imaging units are arrayed have been described for the imaging optical system in the embodiments, but the number of imaging units is not restricted thereto, and an imaging optical system may be configured having three or more imaging units. Also, while the imaging unit in the sixth embodiment is of a configuration having two lens rows in the second direction, an imaging unit may be configured having three or more lens rows in the second direction.

[0211] Also, while the light source according to the embodiments has been described as a configuration where multiple light-emitting points are arrayed in a first direction alone, a configuration may be employed where multiple rows of the light-emitting points are arrayed in the second direction, and the multiple light-emitting points are arrayed in a staggered layout. This configuration enables a greater number of light-emitting points to be densely arrayed without consideration of space to other light-emitting points adjacent in the first direction, so resolution can be further improved.

[0212] The recording density of the above-described image forming apparatus and image reading apparatus is not restricted. However, when taking into consideration that the higher the recording density is, the higher the demanded

image quality is, the optical apparatus according to the above-described embodiments exhibits greater advantages in image formation apparatuses of 1200 dpi or higher.

[0213] This application claims the benefit of Japanese Patent Application No. 2012-284439, filed December 27, 2012, which is hereby incorporated by reference herein in its entirety.

CLAIMS

[1] An optical apparatus comprising:

a light source including a plurality of light-emitting points arrayed in a first direction; and

an imaging optical system including a plurality of lens optical systems arrayed in the first direction;

wherein the imaging optical system forms images of the plurality of light-emitting points on a light-receiving surface;

and wherein conditions of

[Math. 1]

$$0.8 \leq \frac{P_m}{P_s} \frac{1 - P_s D_s \tan \theta_m}{1 - P_m D_m \tan \theta_s} \leq 1.2$$

are satisfied, where

in a first cross-section which is parallel to the first direction and an axial direction of the lens optical systems, θ_m represents a half-value of a maximum value of angle of divergence of an imaging optical flux input to the light-receiving surface, P_m represents resolution, and D_m represents a size of each image of the plurality of light-emitting points, formed on the light-receiving surface, and

in a second cross-section which is perpendicular to the first direction, θ_s represents a half-value of a maximum value of angle of divergence of an imaging optical flux

input to the light-receiving surface, P_s represents resolution, and D_s represents a size of each image of the plurality of light-emitting points, formed on the light-receiving surface.

[2] The optical apparatus according to Claim 1, wherein θ_m is θ_m' which is half-value of a maximum value of effective angle of divergence, and θ_s is θ_s' which is half-value of a maximum value of effective angle of divergence.

[3] The optical apparatus according to Claim 1, wherein the imaging optical system performs erecting same-size imaging of each of the plurality of light-emitting points on the light-receiving surface in the first cross-section, and performs inverted imaging of each of the plurality of light-emitting points on the light-receiving surface in the second cross-section.

[4] The optical apparatus according to Claim 1, wherein the plurality of lens optical systems each have an anamorphic surface.

[5] The optical apparatus according to Claim 1, wherein the plurality of lens optical systems each include a plurality of lens portions arrayed in the optical axis direction of the lens optical systems.

[6] The optical apparatus according to Claim 1, wherein the imaging optical system is an enlarging system in the second cross-section.

[7] The optical apparatus according to Claim 1, wherein the plurality of light-emitting points are organic light-emitting devices.

[8] An optical apparatus comprising:

a light source including a plurality of light-emitting points arrayed in a first direction; and

an imaging optical system including a plurality of lens optical systems arrayed in the first direction;

wherein the imaging optical system forms images of the plurality of light-emitting points on a light-receiving surface;

and wherein conditions of

[Math. 10]

$$0.8 \leq \frac{P_m}{P_s} \frac{1 - P_s D_s}{1 - P_m D_m} \frac{n_m p}{T} \leq 1.2$$

are satisfied, where

in a first cross-section which is parallel to the first direction and an axial direction of the lens optical systems, p represents an array pitch of the plurality of lens optical systems, n_m represents the maximum number of lens optical systems through which light rays from one of the plurality of light-emitting points pass, P_m represents resolution, and D_m represents a size of each image of the plurality of light-emitting points, formed on the light-receiving surface, and

in a second cross-section which is perpendicular to the first direction, T represents the maximum effective width of the imaging optical system, P_s represents resolution, and D_s represents a size of each image of the plurality of light-emitting points, formed on the light-receiving surface.

[9] The optical apparatus according to Claim 8, wherein the maximum number n_m is the maximum effective number n_m' .

[10] The optical apparatus according to Claim 8, satisfying conditions of

$$n_m \leq 4.$$

[11] The optical apparatus according to Claim 8, wherein the imaging optical system performs erecting same-size imaging of each of the plurality of light-emitting points on the light-receiving surface in the first cross-section, and performs inverted imaging of each of the plurality of light-emitting points on the light-receiving surface in the second cross-section.

[12] The optical apparatus according to Claim 8, wherein the plurality of lens optical systems each have an anamorphic surface.

[13] The optical apparatus according to Claim 8, wherein the plurality of lens optical systems each include a plurality of lens portions arrayed in the optical axis direction of the lens optical systems.

[14] An image forming apparatus comprising:

an optical apparatus including

a light source including a plurality of light-emitting points arrayed in a first direction, and

an imaging optical system including a plurality of lens optical systems arrayed in the first direction;

wherein the imaging optical system forms images of the plurality of light-emitting points on a light-receiving surface;

wherein conditions of

[Math. 1]

$$0.8 \leq \frac{P_m}{P_s} \frac{1 - P_s D_s \tan \theta_m}{1 - P_m D_m \tan \theta_s} \leq 1.2$$

are satisfied, where

in a first cross-section which is parallel to the first direction and an axial direction of the lens optical systems, θ_m represents a half-value of a maximum value of angle of divergence of an imaging optical flux input to the light-receiving surface, P_m represents resolution, and D_m represents a size of each image of the plurality of light-emitting points, formed on the light-receiving surface, and

in a second cross-section which is perpendicular to the first direction, θ_s represents a half-value of a maximum value of angle of divergence of an imaging optical flux input to the light-receiving surface, P_s represents resolution, and D_s represents a size of each image of the

plurality of light-emitting points, formed on the light-receiving surface;

a developing unit configured to develop an electrostatic latent image, formed on a photosensitive surface disposed on a photosensitive member, by the optical apparatus as a toner image;

a transfer unit configured to transfer the developed toner image to a transfer medium; and

a fixing unit configured to fix the transferred toner image into the transfer medium;

wherein the imaging optical system is disposed such that the second direction perpendicular to the first direction and optical axis direction of the lens optical systems is the rotational direction of the photosensitive member.

[15] An optical apparatus comprising:

an imaging optical system including a plurality of lens optical systems arrayed in the first direction;

wherein the imaging optical system forms images of a document on a light-receiving surface;

and wherein conditions of

[Math. 26]

$$0.8 \leq \frac{P_m \tan \theta_m}{P_s \tan \theta_s} \leq 1.2$$

are satisfied, where

in a first cross-section which is parallel to the first direction and an axial direction of the lens optical systems, θ_m represents a half-value of a maximum value of angle of divergence of an imaging optical flux input to the photoreception unit, and P_m represents resolution, and

in a second cross-section which is perpendicular to the first direction, θ_s represents a half-value of a maximum value of angle of divergence of an imaging optical flux input to the light-receiving surface, and P_s represents resolution.

[16] The optical apparatus according to Claim 15, wherein θ_m is θ_m' which is half-value of a maximum value of effective angle of divergence, and θ_s is θ_s' which is half-value of a maximum value of effective angle of divergence.

[17] An optical apparatus comprising:

an imaging optical system including a plurality of lens optical systems arrayed in the first direction;

wherein the imaging optical system forms an image of a document on a light-receiving surface;

and wherein conditions of

[Math. 27]

$$0.8 \leq \frac{P_m n_m p}{P_s T} \leq 1.2$$

are satisfied, where

in a first cross-section which is parallel to the first

direction and an axial direction of the lens optical systems, p represents an array pitch of the plurality of lens optical systems, n_m represents the maximum number of lens optical systems through which light rays from one of the plurality of light-emitting points pass, P_m represents resolution, and

is a second cross-section perpendicular to the first cross-section, T represents the maximum effective width of the imaging optical system, and P_s represents resolution.

[18] The optical apparatus according to Claim 17, wherein the maximum number n_m is the maximum effective number n_m' .

[19] An image reading apparatus comprising:

an optical apparatus including

an imaging optical system including a plurality of lens optical systems arrayed in a first direction,

wherein the imaging optical system forms images of the plurality of light-emitting points on a light-receiving surface;

wherein conditions of

[Math. 26]

$$0.8 \leq \frac{P_m \tan \theta_m}{P_s \tan \theta_s} \leq 1.2$$

are satisfied, where

in a first cross-section which is parallel to the first direction and an axial direction of the lens optical systems, θ_m represents a half-value of a maximum value of

angle of divergence of an imaging optical flux input to the light-receiving surface, and P_m represents resolution, and

in a second cross-section which is perpendicular to the first direction, θ_s represents a half-value of a maximum value of angle of divergence of an imaging optical flux input to the light-receiving surface, and P_s represents resolution;

an illumination unit configured to irradiate the document;

a photoreceptor unit disposed at the image plane of the imaging optical system, configured to receive light rays of the document on which light has been condensed by the imaging optical system; and

a driving unit configured to change a relative position between the imaging optical system and the document in a second direction perpendicular to the first direction and the optical axis direction of the lens optical system.

1 / 17

FIG. 1A

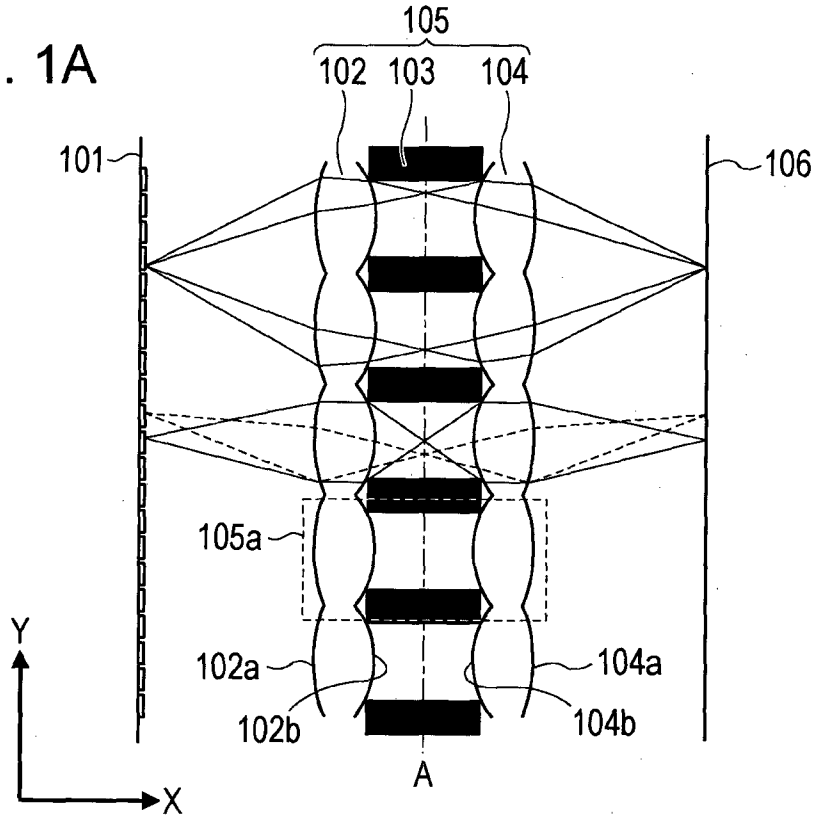

FIG. 1B

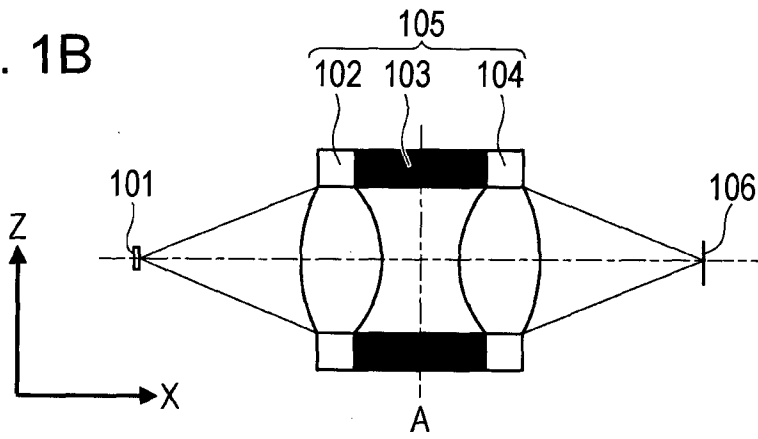

FIG. 1C

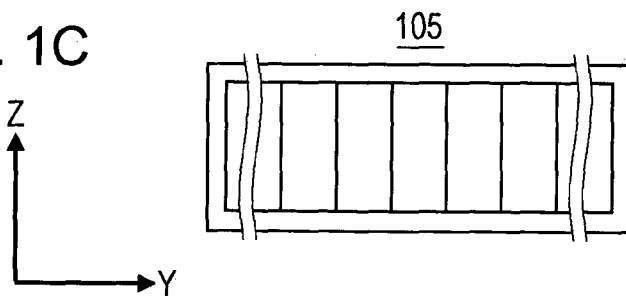

FIG. 2

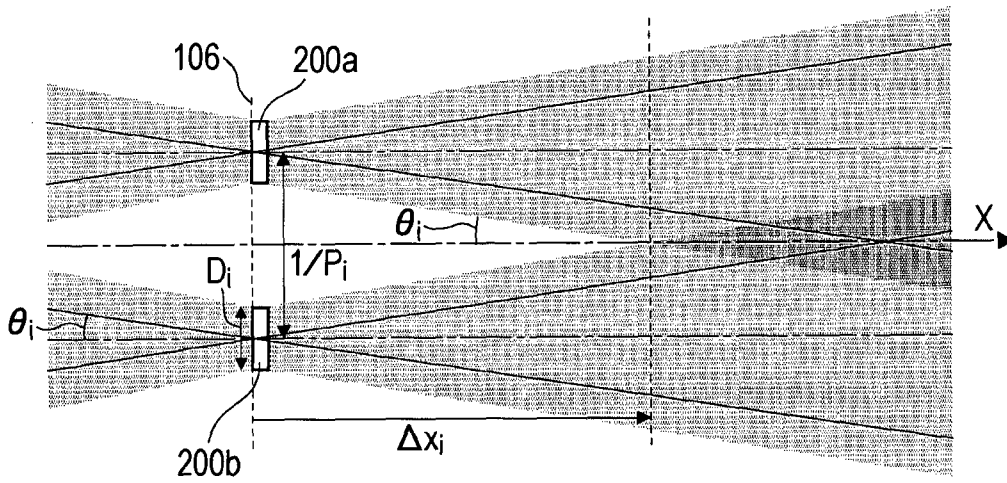

FIG. 3A

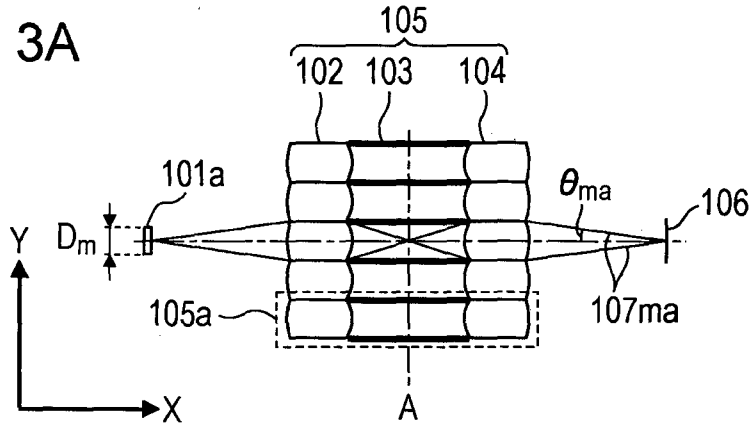

FIG. 3B

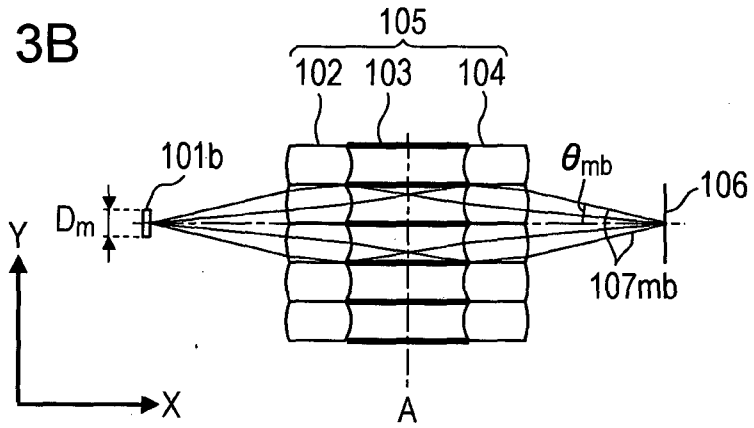

FIG. 3C

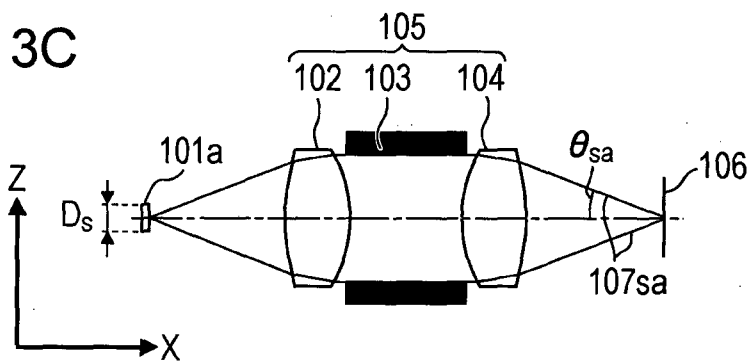

FIG. 3D

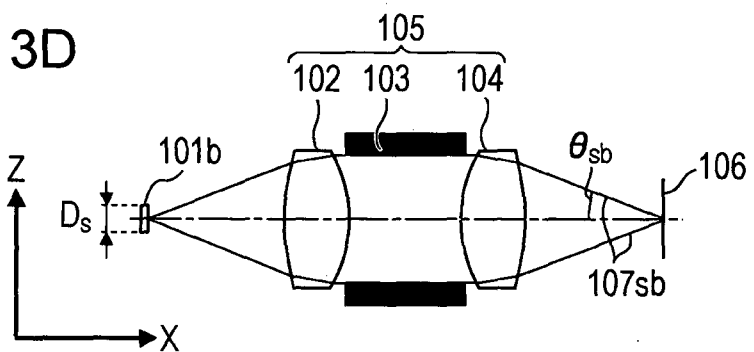

FIG. 4A

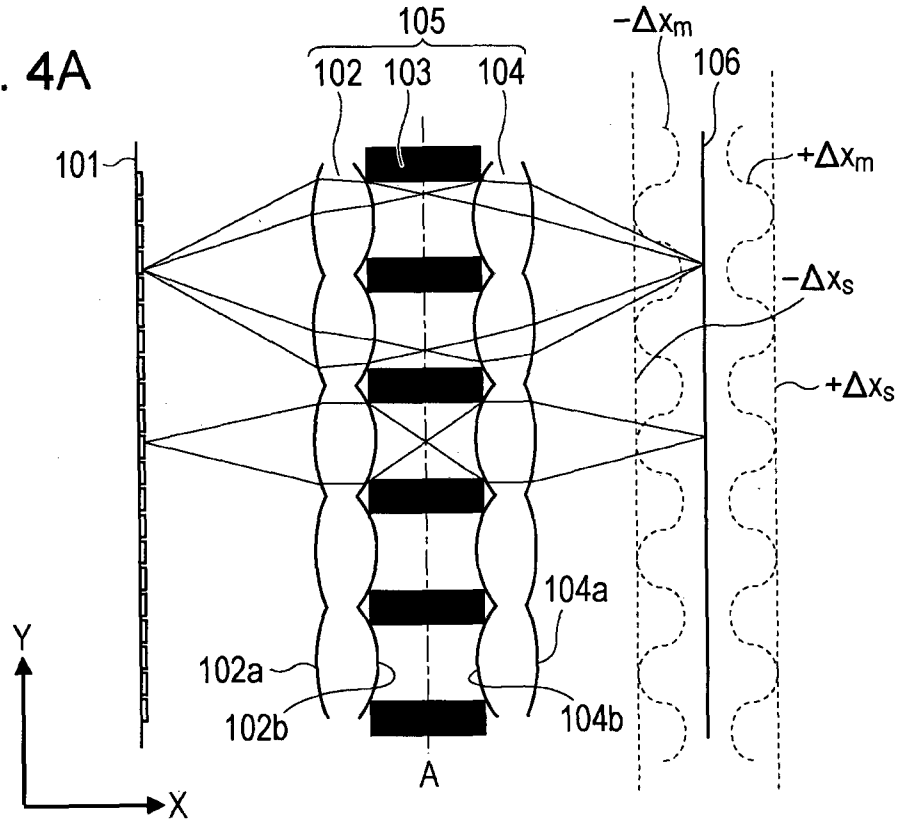
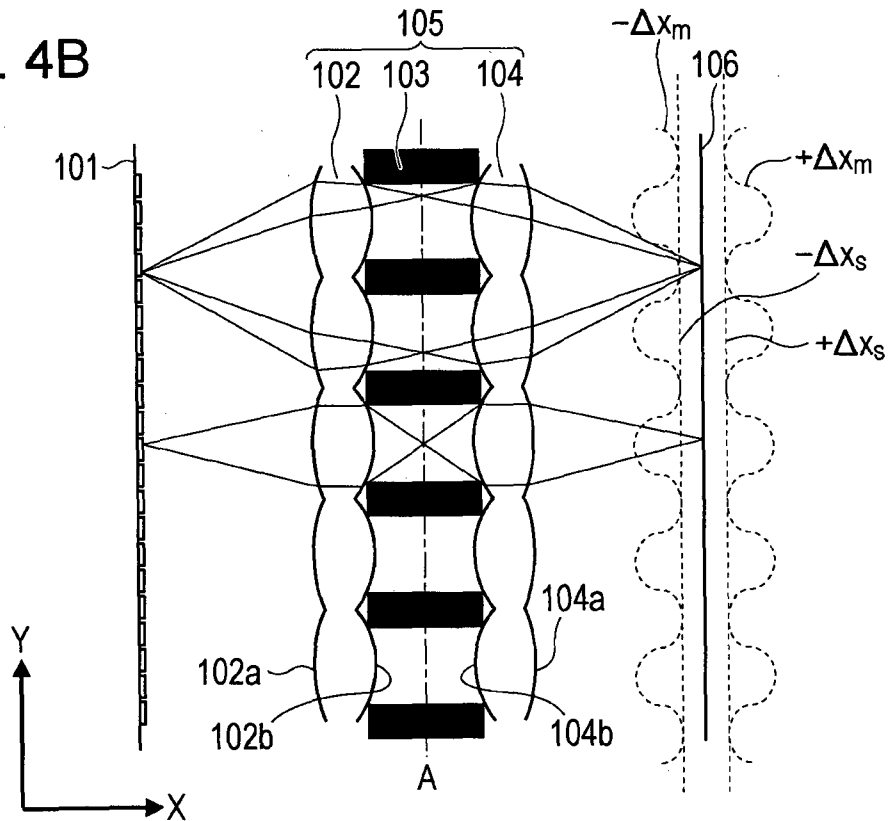

FIG. 4B



5/17

FIG. 5A

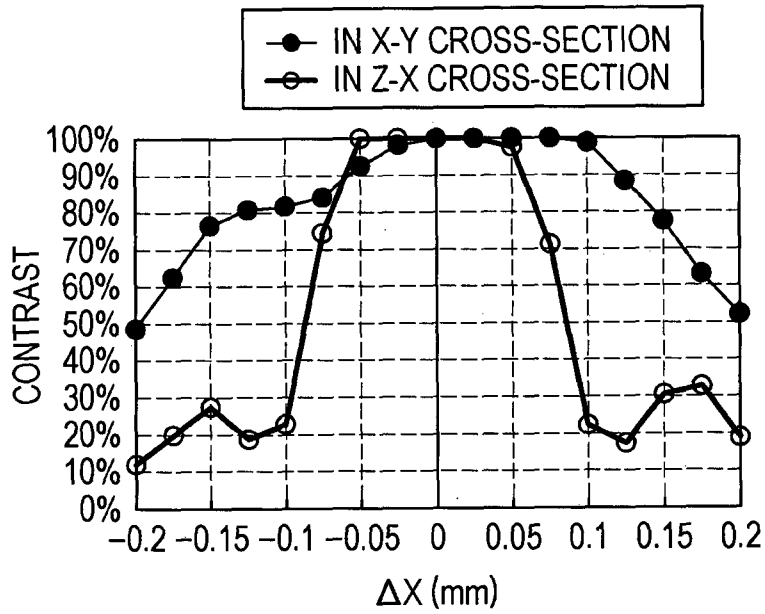
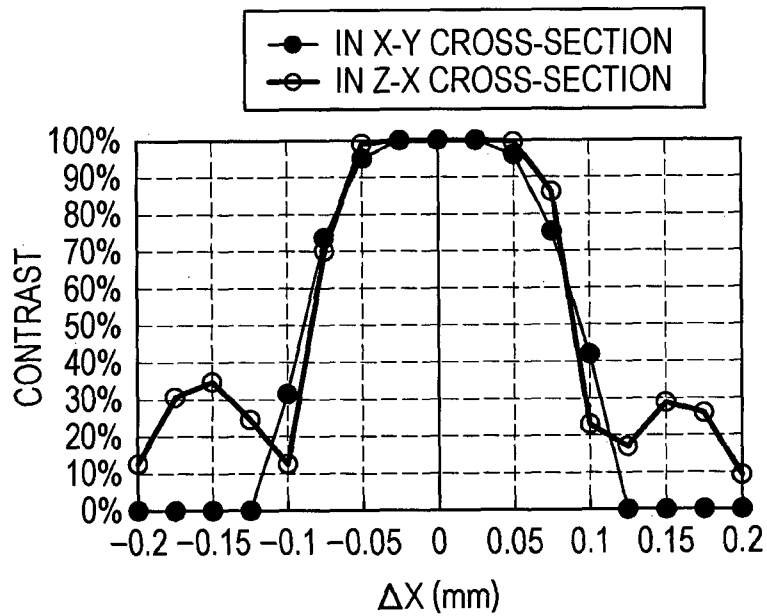

FIG. 5B



6/17

FIG. 6A

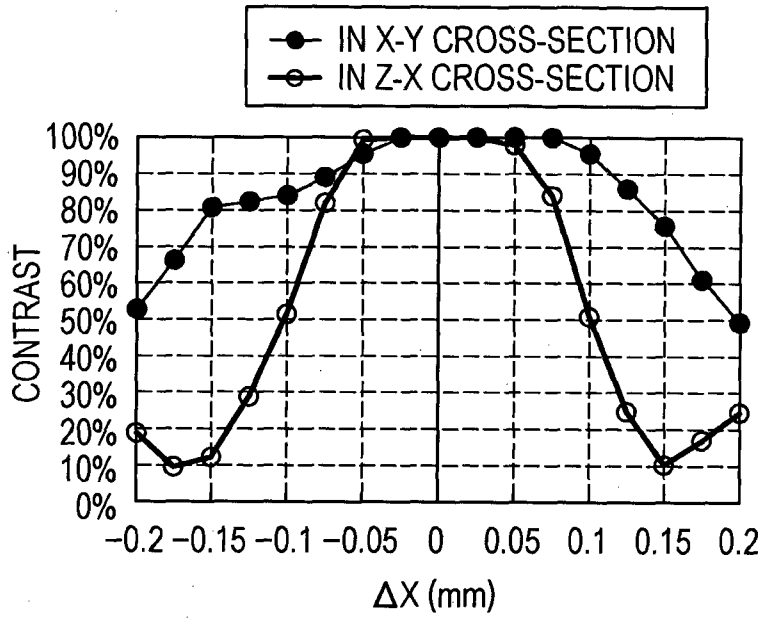
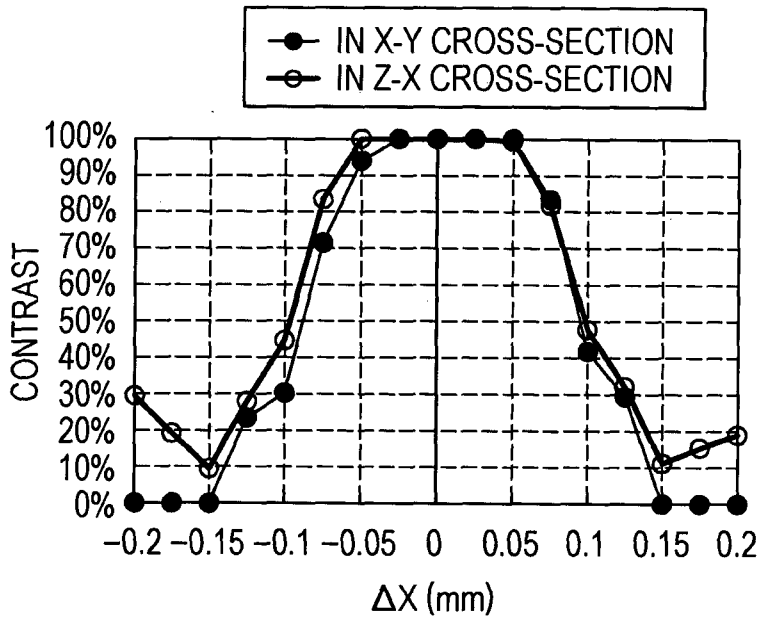

FIG. 6B



7/17

FIG. 7A

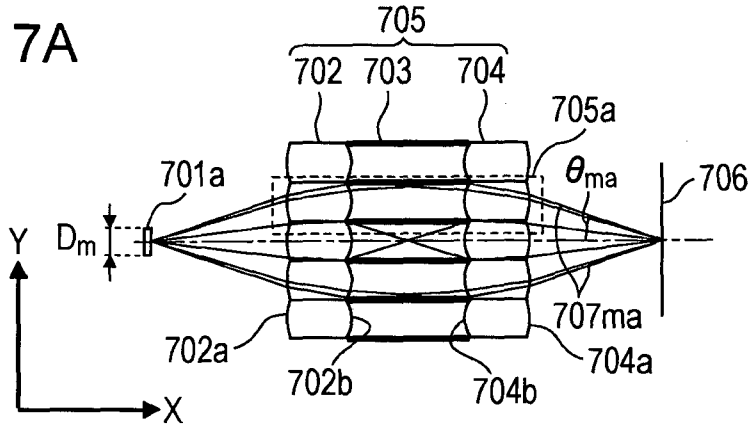

FIG. 7B

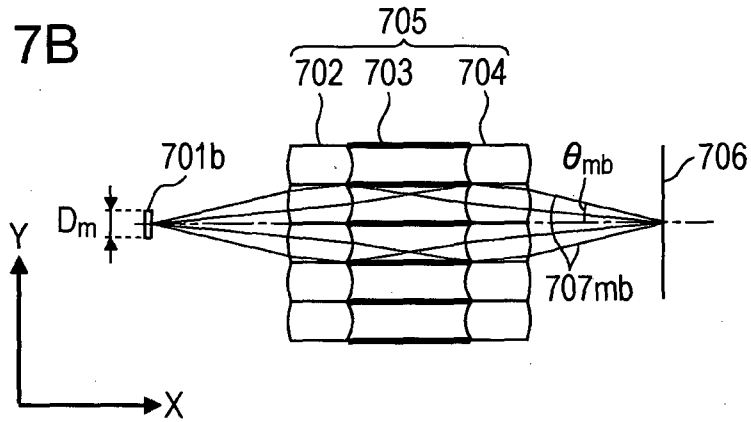

FIG. 7C

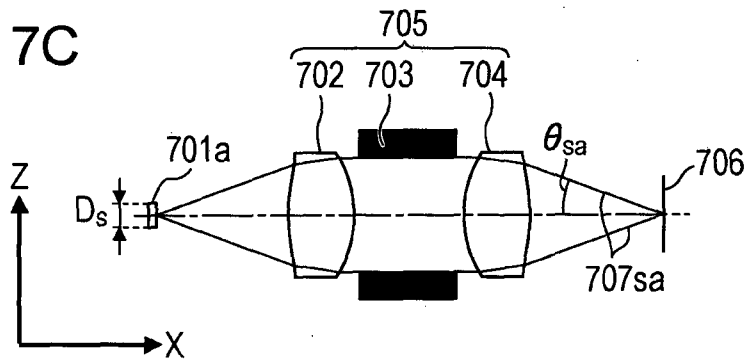
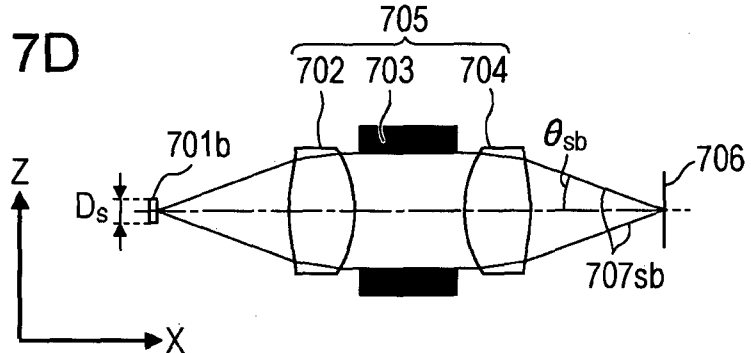

FIG. 7D



8/17

FIG. 8A

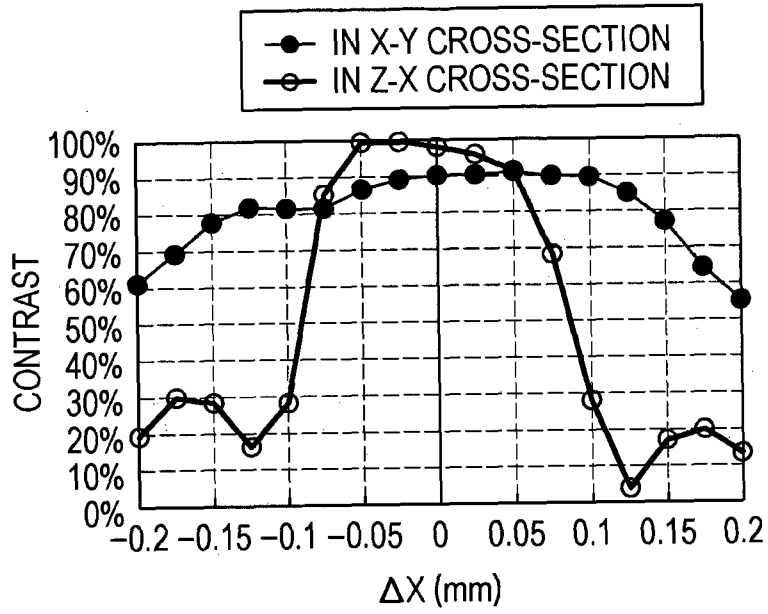
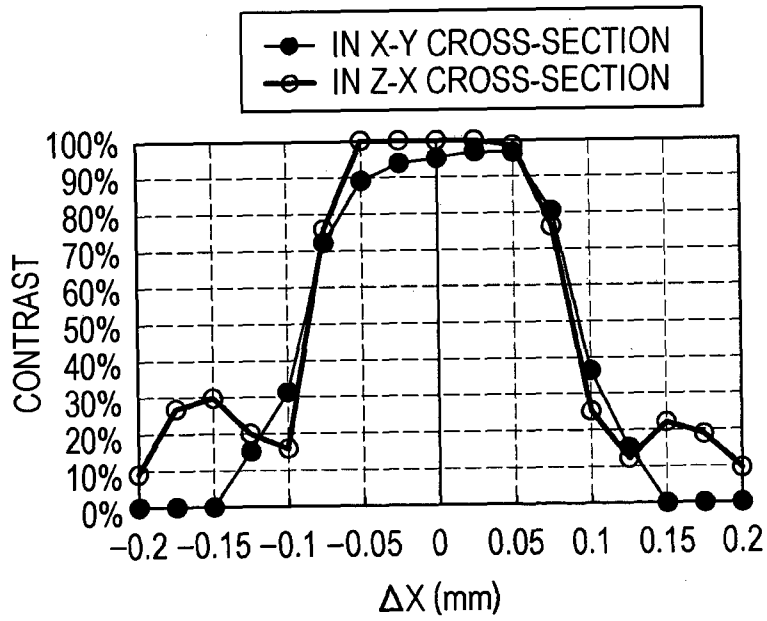
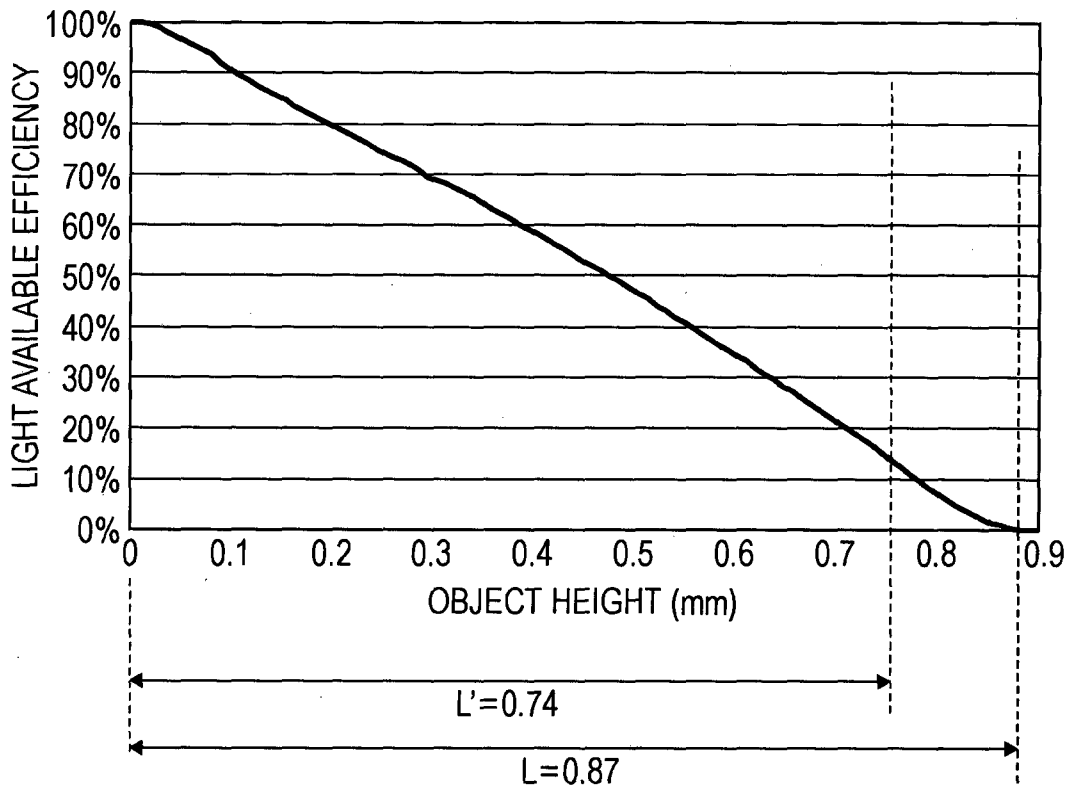

FIG. 8B



9/17

FIG. 9



10/17

FIG. 10A

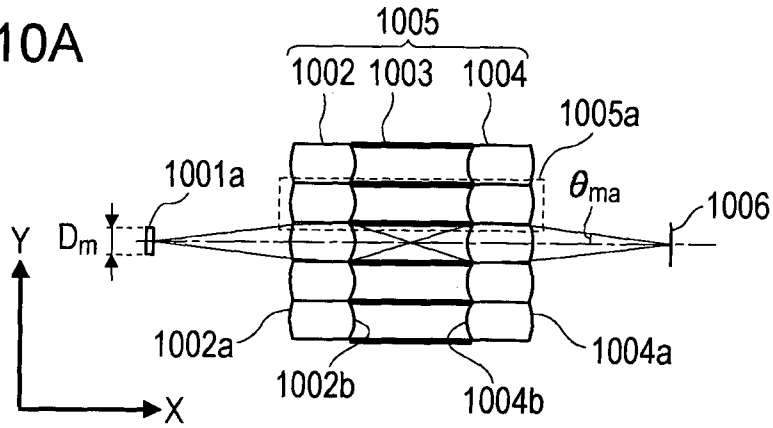

FIG. 10B

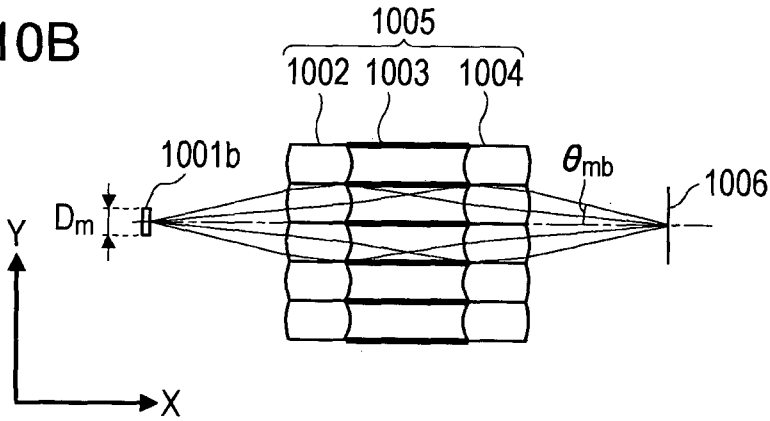

FIG. 10C

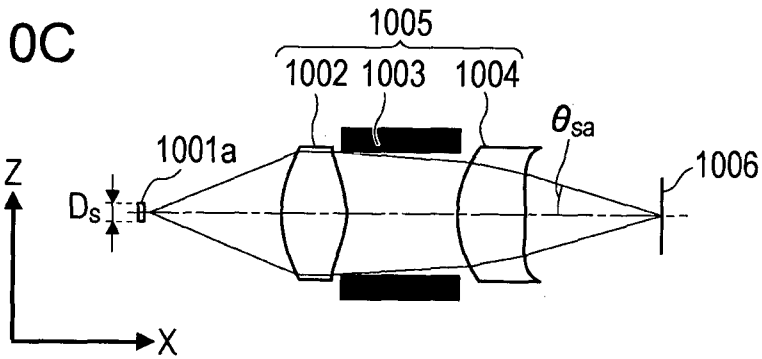
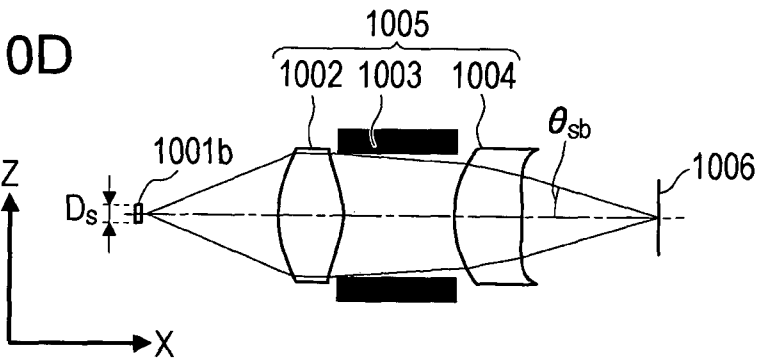

FIG. 10D



11 / 17

FIG. 11A

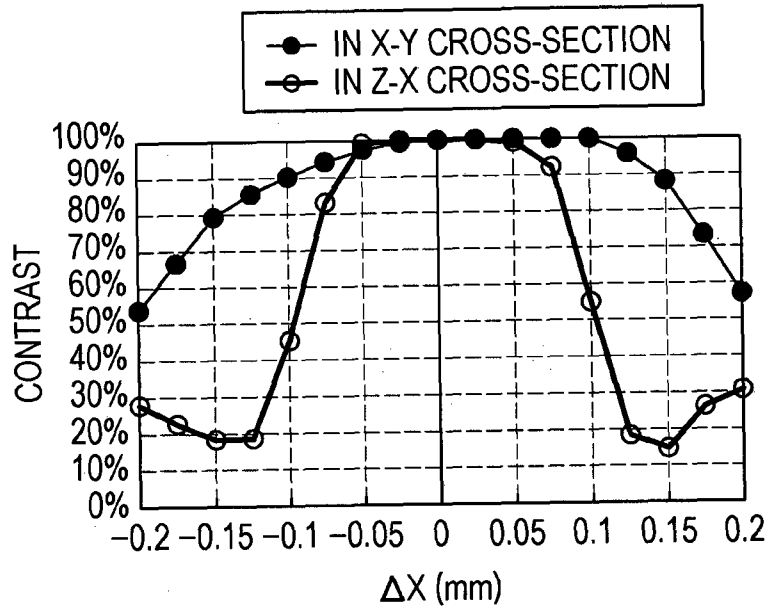
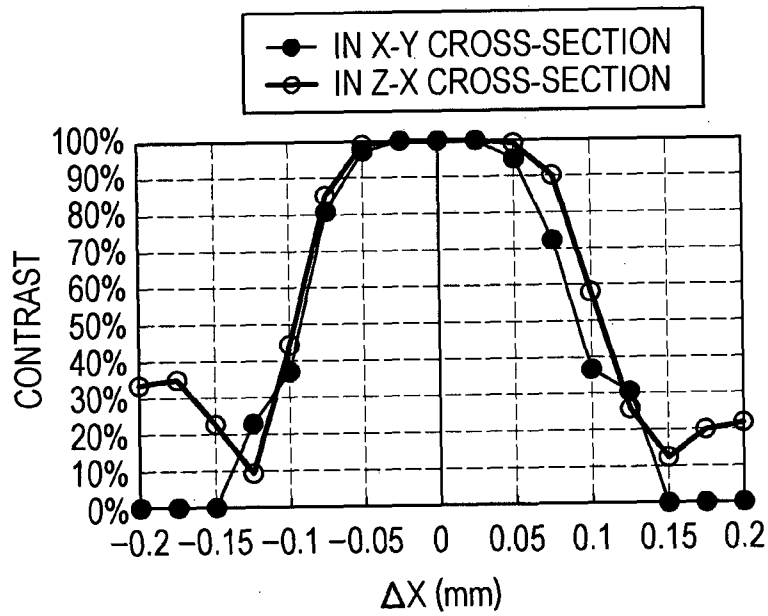
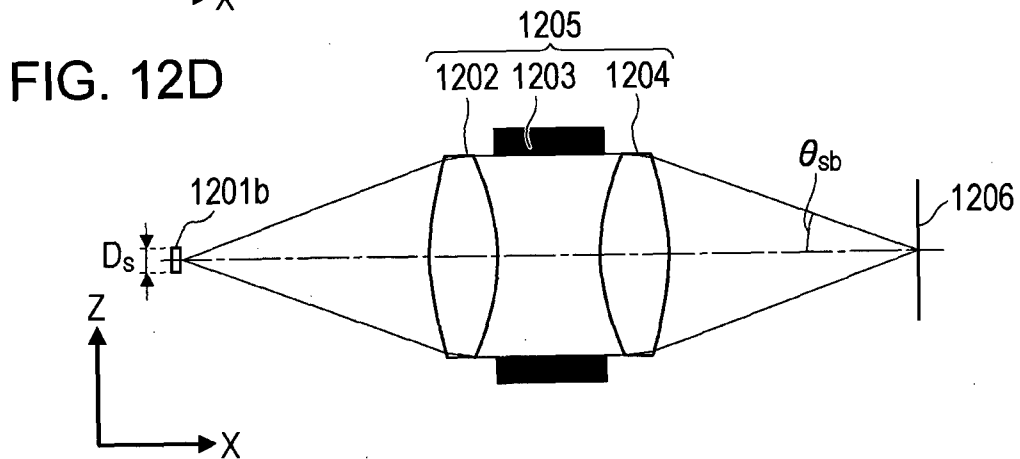
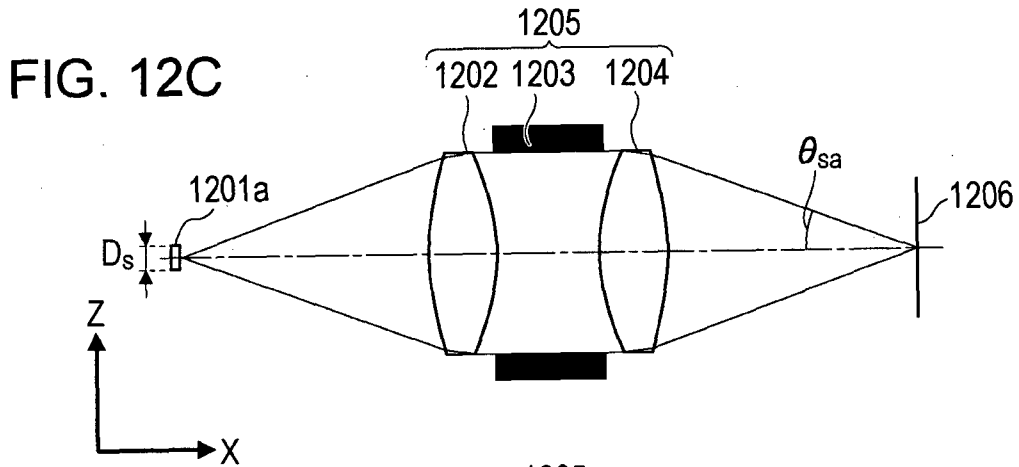
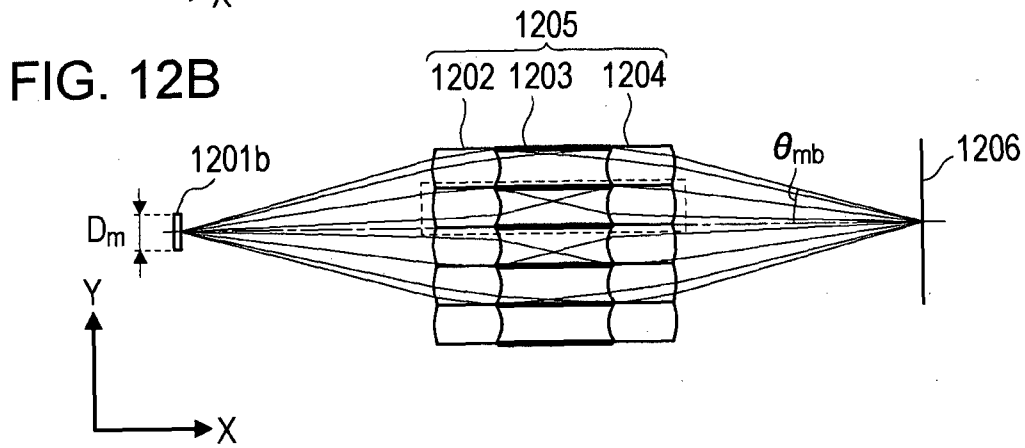
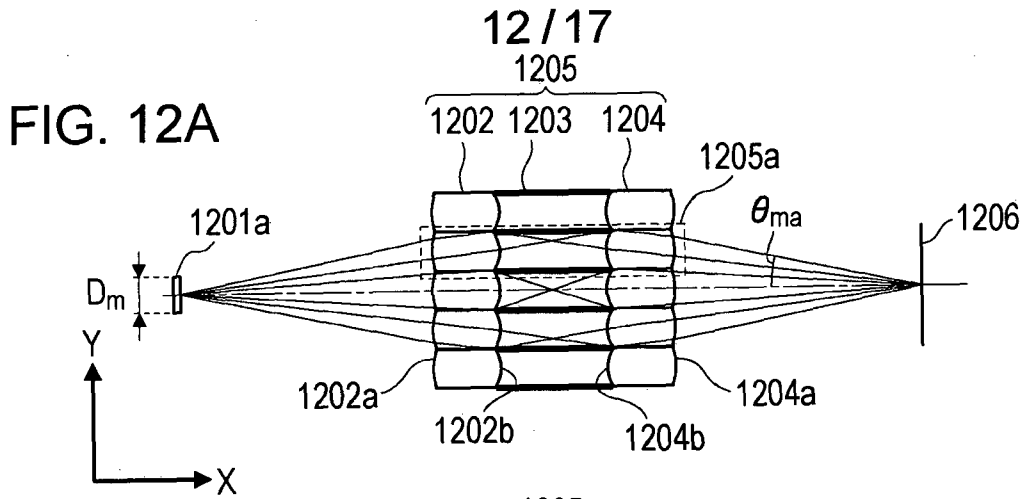

FIG. 11B





13/17

FIG. 13A

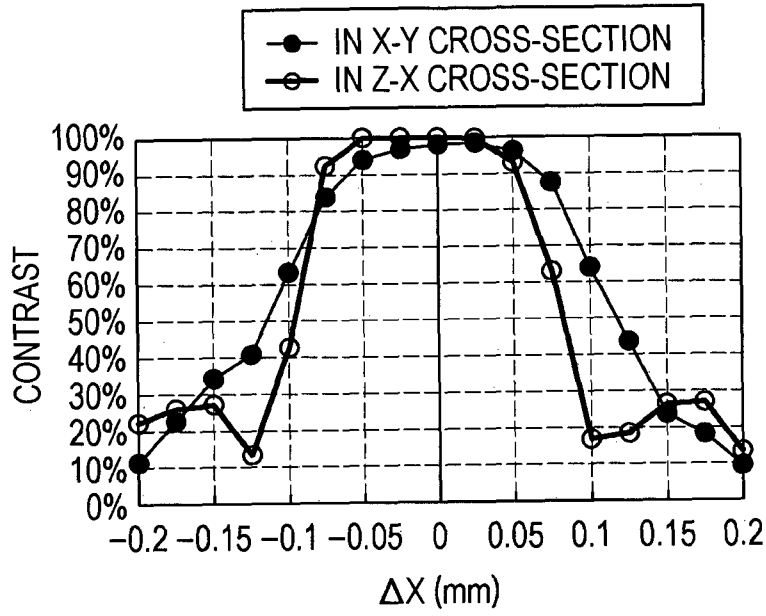
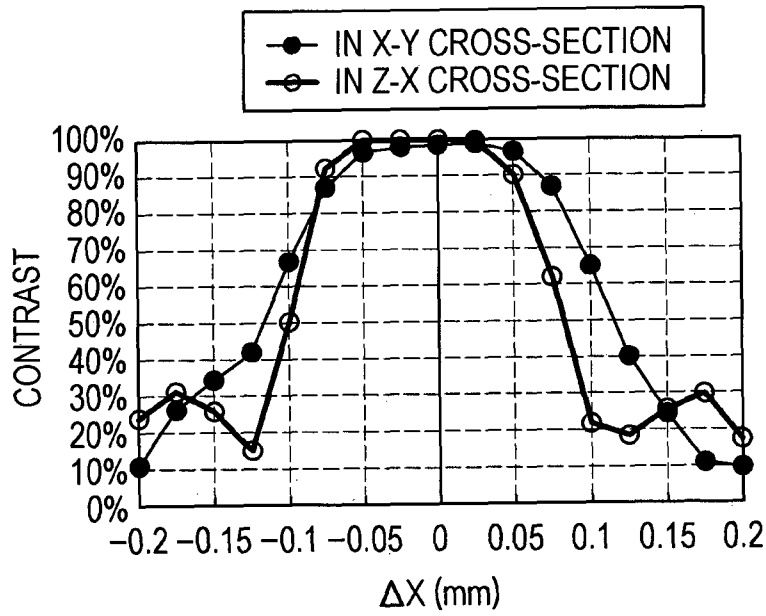

FIG. 13B



14 / 17

FIG. 14A

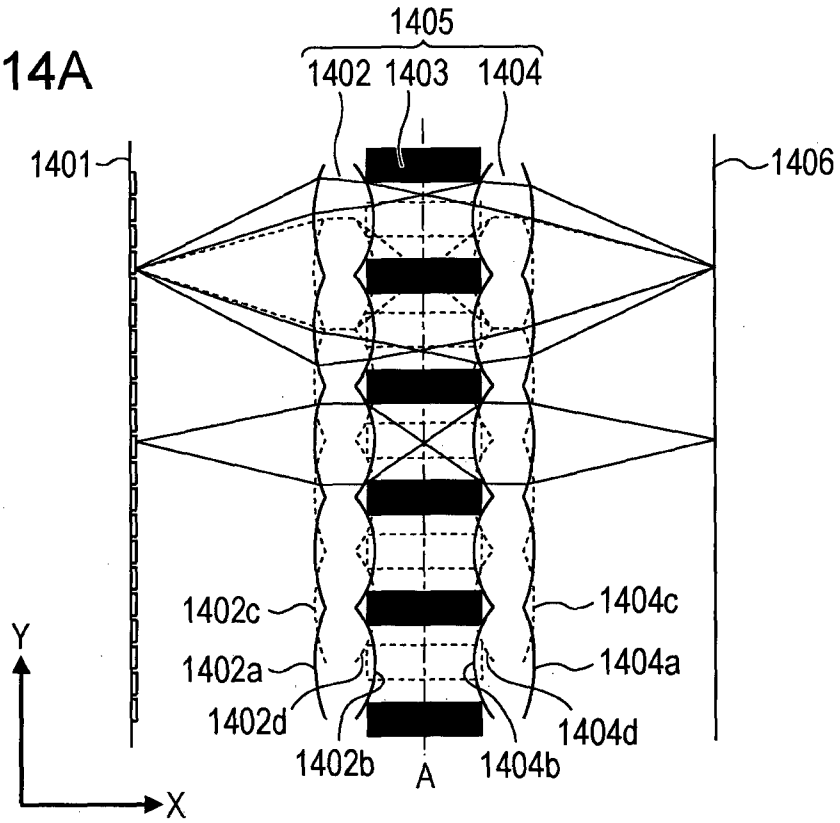

FIG. 14B

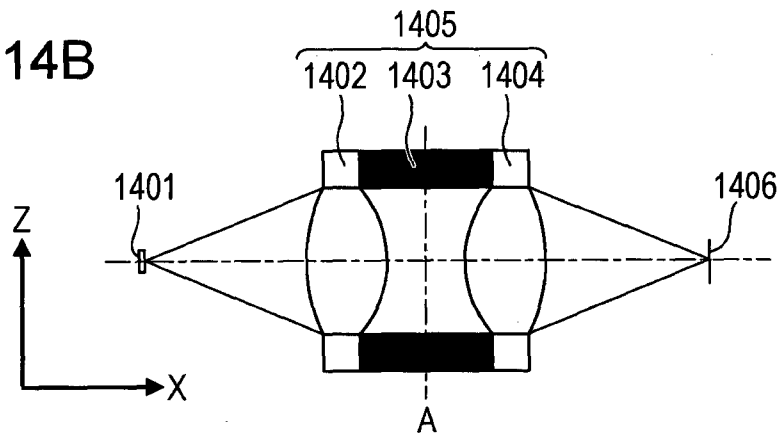
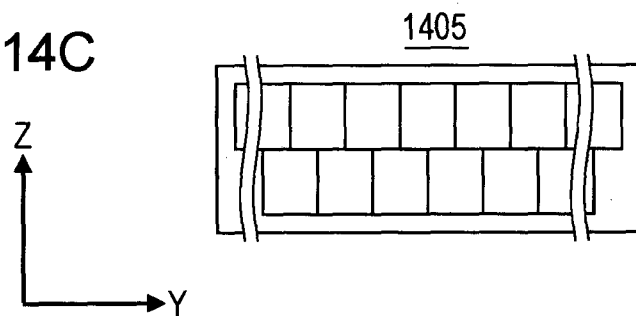

FIG. 14C



15 / 17

FIG. 15A

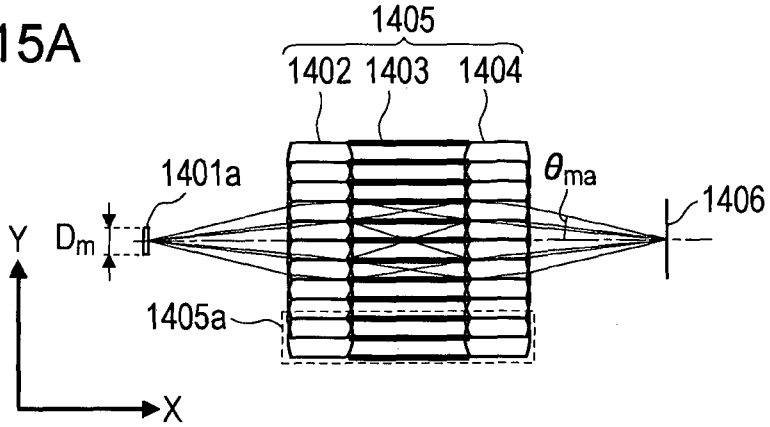

FIG. 15B

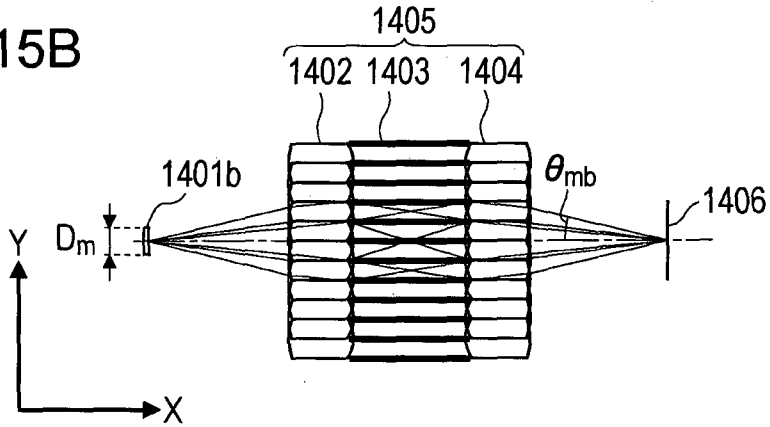

FIG. 15C

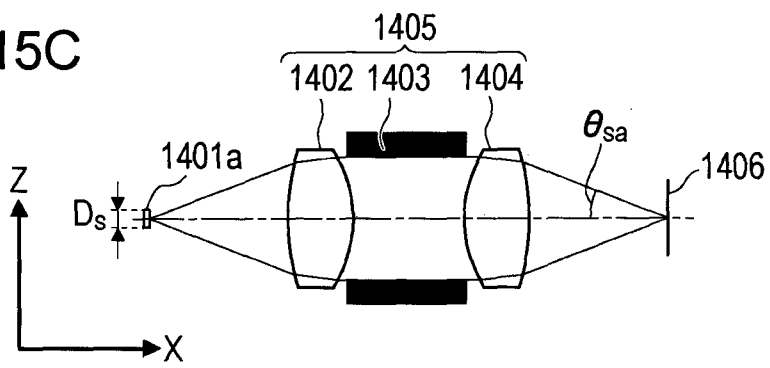
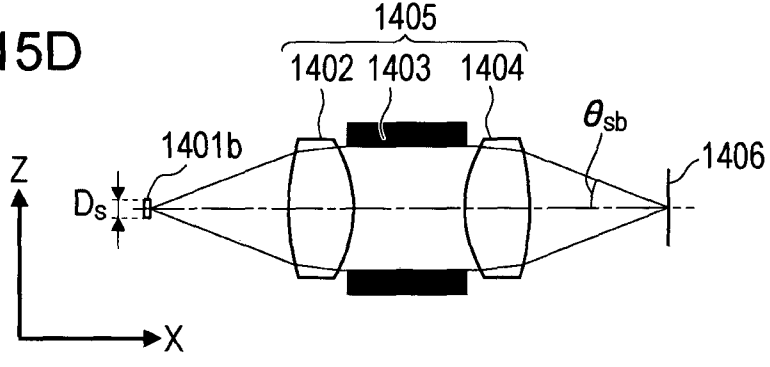

FIG. 15D



16 / 17

FIG. 16A

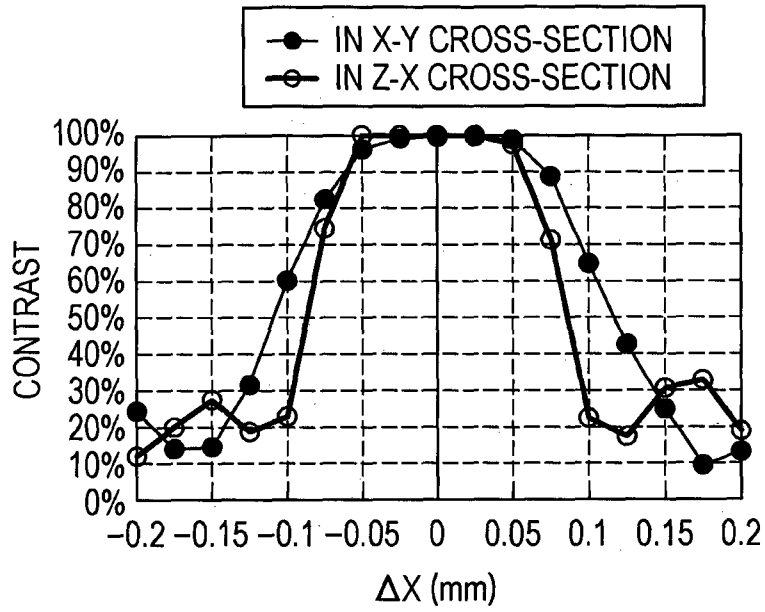
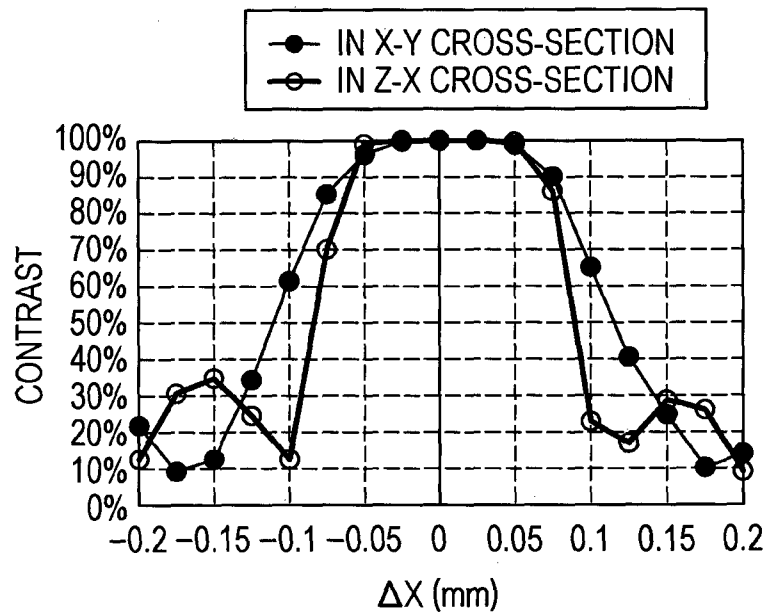
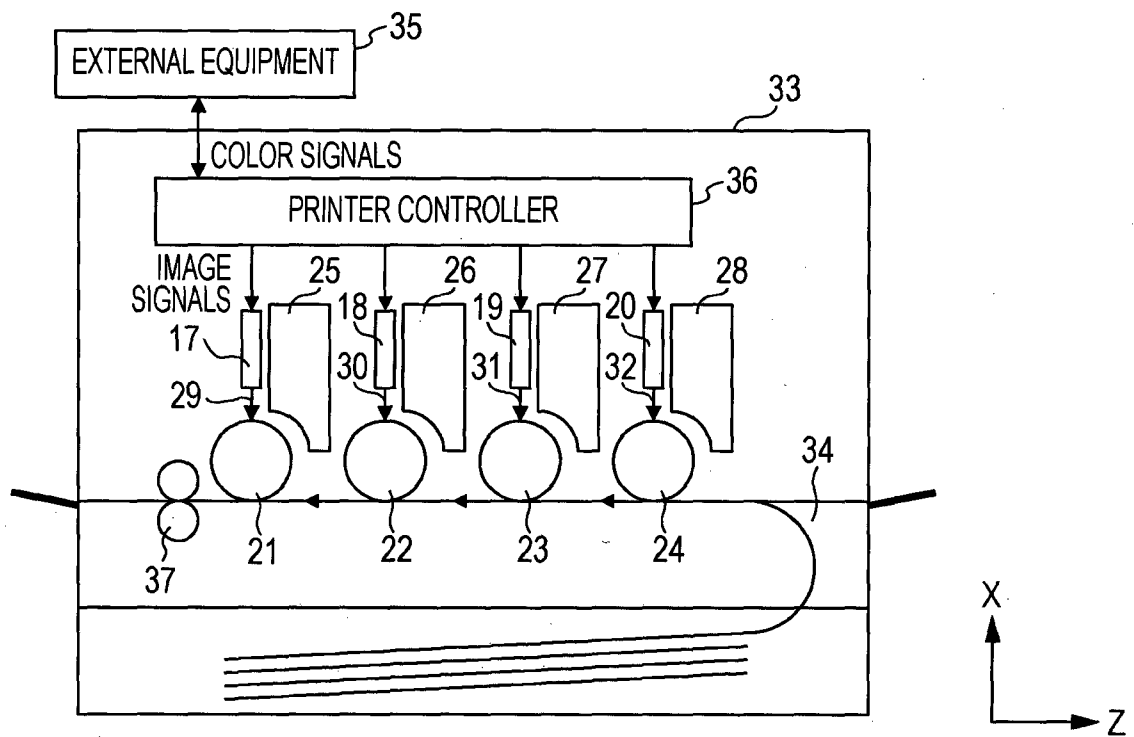

FIG. 16B



17/17

FIG. 17



INTERNATIONAL SEARCH REPORT

International application No.
PCT/JP2013/085017

A. CLASSIFICATION OF SUBJECT MATTER		
Int.Cl. See extra sheet		
According to International Patent Classification (IPC) or to both national classification and IPC		
B. FIELDS SEARCHED		
Minimum documentation searched (classification system followed by classification symbols)		
Int.Cl. G02B13/26, G02B27/18, G03B27/54, G03G15/04, H04N1/028, H04N1/036, G02B3/00, G02B3/06		
Documentation searched other than minimum documentation to the extent that such documents are included in the fields searched		
Published examined utility model applications of Japan 1922-1996 Published unexamined utility model applications of Japan 1971-2014 Registered utility model specifications of Japan 1996-2014 Published registered utility model applications of Japan 1994-2014		
Electronic data base consulted during the international search (name of data base and, where practicable, search terms used)		
C. DOCUMENTS CONSIDERED TO BE RELEVANT		
Category*	Citation of document, with indication, where appropriate, of the relevant passages	Relevant to claim No.
A	JP 2011-221175 A (Sumitomo Electric Industries, Ltd.) 04 November, 2011(04.11.11), Par. Nos. [0016] to [0056] , Figs. 1 to 3 (No Family)	1-19
A	JP 2010-008783 A (Oki Data Corp.) 14 January, 2010(14.01.10), Par. Nos. [0016] to [0170], Figs. 1 to 4 & US 2009/0322847 A1	1-19
A	JP 2009-098613 A (Seiko Epson Corp.) 07 May, 2009(07.05.09), Par. Nos. [0027] to [0115], All Figures & US 2009/0086328 A1	1-19
<input checked="" type="checkbox"/> Further documents are listed in the continuation of Box C. <input type="checkbox"/> See patent family annex.		
* Special categories of cited documents: "A" document defining the general state of the art which is not considered to be of particular relevance "E" earlier application or patent but published on or after the international filing date "L" document which may throw doubts on priority claim(s) or which is cited to establish the publication date of another citation or other special reason (as specified) "O" document referring to an oral disclosure, use, exhibition or other means "P" document published prior to the international filing date but later than the priority date claimed "T" later document published after the international filing date or priority date and not in conflict with the application but cited to understand the principle or theory underlying the invention "X" document of particular relevance; the claimed invention cannot be considered novel or cannot be considered to involve an inventive step when the document is taken alone "Y" document of particular relevance; the claimed invention cannot be considered to involve an inventive step when the document is combined with one or more other such documents, such combination being obvious to a person skilled in the art "&" document member of the same patent family		
Date of the actual completion of the international search 10.02.2014		Date of mailing of the international search report 25.02.2014
Name and mailing address of the ISA/JP Japan Patent Office 3-4-3, Kasumigaseki, Chiyoda-ku, Tokyo 100-8915, Japan		Authorized officer YAMAMOTO, Kiichi Telephone No. +81-3-3581-1101 Ext. 3255
		2L 4086

INTERNATIONAL SEARCH REPORTInternational application No.
PCT/JP2013/085017

C (Continuation). DOCUMENTS CONSIDERED TO BE RELEVANT		
Category*	Citation of document, with indication, where appropriate, of the relevant passages	Relevant to claim No.
A	JP 06-250117 A (Mitsubishi Rayon Co., Ltd.) 09 September, 1994 (09.09.94), Par. Nos. [0015] to [0024], All Figures (No Family)	1-19

INTERNATIONAL SEARCH REPORT

International application No.

PCT/JP2013/085017

CLASSIFICATION OF SUBJECT MATTER

G02B13/26(2006.01) i, G02B27/18(2006.01) i, G03B27/54(2006.01) i,
G03G15/04(2006.01) i, H04N1/028(2006.01) i, H04N1/036(2006.01) i,
G02B3/00(2006.01) n, G02B3/06(2006.01) n