

May 12, 1942.

W. W. MILLER

2,282,590

GALVANOMETER

Filed June 27, 1939

FIG. 1.

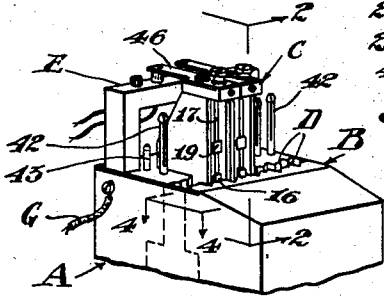

FIG. 3.

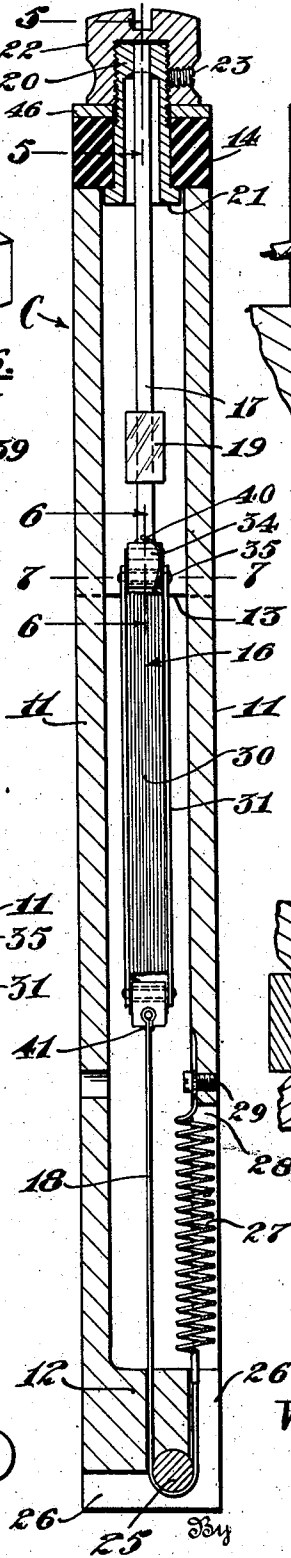

FIG. 2.

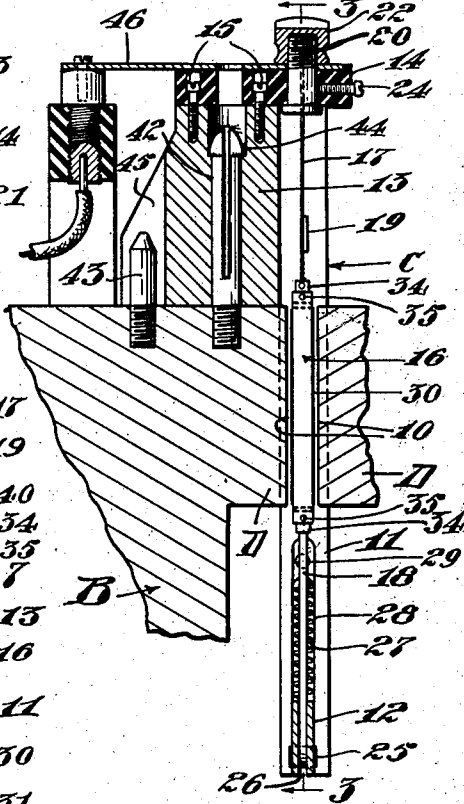

FIG. 6.

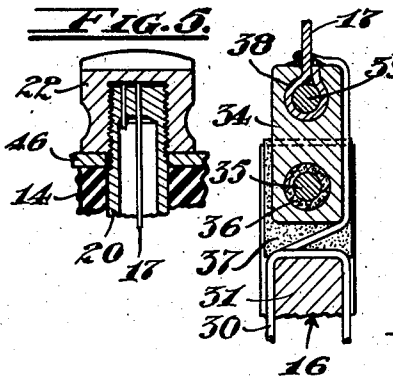

FIG. 5.

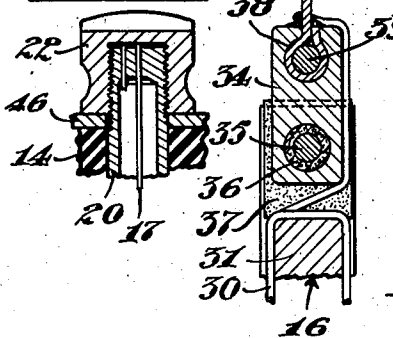

FIG. 7.

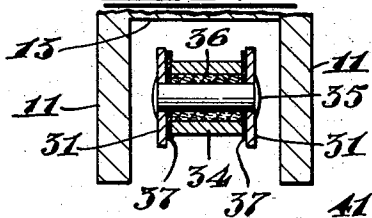

FIG. 8.

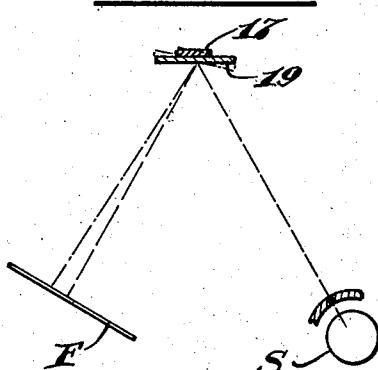
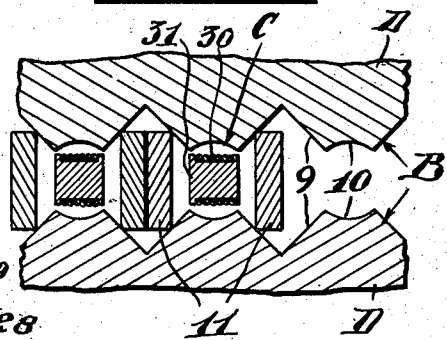

FIG. 4.



Inventor  
William W. Miller

*R. S. Brumby*  
Attorney

# UNITED STATES PATENT OFFICE

2,282,590

## GALVANOMETER

William W. Miller, Pasadena, Calif., assignor to  
William Miller Corporation, a corporation of  
California

Application June 27, 1939, Serial No. 281,443

3 Claims. (Cl. 171-95)

My invention has for a purpose the provision of an improved d'Arsonval type of multiple galvanometer which is adapted for general usage as well as especially suited to the making of photographic seismographic and oscillographic recordings in that it is characterized by greater ruggedness, compactness and reliability of performance than heretofore attained due to the manner of combining a plurality of coil assemblies or elements as separate units with a single magnet and the provision for readily and easily removing and replacing such elements, as well as by reason of features of construction and arrangement whereby the coil elements are effectively damped against transverse and other non-galvanometric or extraneous vibrations and made more rugged and compact without sacrificing sensitivity, uniformity and accuracy of operation.

An important object of my invention is to provide an improved multiple galvanometer of the character described which will be superior to multiple galvanometers as heretofore used by reason of the features of construction and arrangement as follows:

1. An especially constructed accurately machined bobbin facilitating the winding of a more uniform coil, and the desired damping thereof, and having attaching means at its terminals for making a rugged and strong mechanical and electrical connection of the coil with right angularly disposed coil suspension ribbons.

2. Suspension ribbons for the coil arranged with their flat sides angularly related to provide for a more convenient and compact arrangement of a pulley and spring employed to place the coil and ribbons under tension; and reduce transverse vibration of the coil assembly, there being special construction of the suspension terminals of the ribbons to provide for a stronger and more rugged connection thereof with associated parts.

3. A hollow torsion head associated with one of the ribbons for reducing the length of and making the element more compact as well as for regulating the position and action of the reflector or indicator which is supported on said one ribbon.

4. The location of the coil elements in the gap between the poles of the magnet and the construction of the elements and magnet facilitating the removal of each element independently of the pole pieces and magnet structure.

5. The use of a plurality of coils in a single magnetic gap or in multiple gaps fed by a magnet or magnets common to all.

Another purpose of my invention is to provide a novel galvanometer coil unit or assembly which is constructed so that it readily lends itself to various uses and will provide for an improved galvanometer wherein the unit may be readily and accurately positioned in the gap between pole pieces of the magnet subject to ready removal and replacement at will entirely separate from the pole pieces and magnet structure.

With the foregoing objects in view, together with such other objects and advantages as may subsequently appear, the invention is carried into effect as illustrated by way of example in the accompanying drawing, in which:

Fig. 1 is a fragmentary perspective view of a multiple galvanometer embodying my invention;

Fig. 2 is a sectional view on the plane of line 2-2 of Fig. 1 particularly showing one of the coil assemblies or elements;

Fig. 3 is a sectional view taken on the line 3-3 of Fig. 2, showing the coil elements as at right angles to that in Fig. 2;

Fig. 4 is an enlarged sectional view taken on the plane of line 4-4 of Fig. 1 and showing the manner of mounting the coil elements between the pole pieces of the magnet;

Fig. 5 is a sectional view of the hollow torsion head taken on the line 5-5 of Fig. 3;

Fig. 6 is a vertical sectional view taken on the line 6-6 of Fig. 3;

Fig. 7 is a horizontal sectional view taken on the line 7-7 of Fig. 3;

Fig. 8 is a diagrammatic view illustrating the manner of use of the galvanometer of my invention for making an oscillographic recording photographically.

One form of the multiple galvanometer embodying my invention is shown in detail in the accompanying drawing and generally comprises a housing A, a permanent magnet B therein, a plurality of separate coil assemblies or elements C mounted in the gap between and supported on the pole pieces D of the magnet, and a terminal block E mounted on said magnet for affording the electrical connection of said elements in the circuits in which they are to be operated, as for example in an oscillograph or the like.

As here shown I may provide the opposed faces of the pole pieces D with like V-shaped recesses 9 separated by shallow grooves 10 for accommodation of the separate coil units C; each of said units being individually supported and held in place in a set of said recesses and depressions as particularly shown in Fig. 4 as will be hereinafter described, whereby to conserve space,

provide for the mounting of a plurality of such units in small compass in a single magnet, and yet permit of separate removal and replacement thereof without disturbing the pole pieces or the other of said coil units.

Each of the coil units or elements C includes a small, elongated open frame having opposed spaced sides 11, a cross piece 12 therebetween at one end of the frame, a laterally extending head piece 13 at the other end of said frame, an insulation block 14, closing the other end of said frame and secured on said head piece by screws 15, a coil 16 suspended in the frame from the ends thereof by means of flat and relatively thin and small metal tapes or ribbons 17 and 18. A mirror or indicator 19 is mounted on the upper ribbon 17, and the upper end of said ribbon is threaded through and soldered to the closed upper end of a hollow torsion head screw 20 rotatably mounted on the insulation block 14 as shown in Fig. 5. This screw has a flange 21 on its lower end, engaging the under side of the block 14 whereas the upper end of said screw is exteriorly threaded for reception of a torsion head cap nut 22 held by a set screw 23 on said torsion head screw. The ribbon 17 and mirror 19 are set in the desired position by turning the nut 22 and screw 20, following which these parts are held in set position by means of a set screw 24, it being noted that the tape or ribbon 17 is extended freely through the hollow screw 20 without contact therewith except at the upper end thereof.

The lower ribbon 18 is extended around a pulley 25 mounted in a slot 26 in the cross piece 12 and soldered or otherwise joined to the one end of a spring 27 mounted in a slot 28 in one of the sides 11. The other end of the spring 27 is fixed by a screw 29 to said side 11 and maintains the ribbons 17 and 18 and coil 16 under tension. It should now be noted that the ribbon 18 is maintained with its flat or wider surfaces parallel to the inner surface of the sides 11 and this affords a mounting of the spring within the confines of the frame which encloses the ribbons 17 and 18 and the coil. On the other hand the ribbon 17 is disposed with its wider surfaces at right angles to the corresponding surfaces of the ribbon 18 and by reason of the two ribbons being angularly disposed in this manner the tendency of the coil and ribbons to vibrate transversely is appreciably reduced.

The coil 16 as best shown in Fig. 3 comprises a fine insulated wire 30 wound around an elongated bobbin 31 which is made of duralumin and machined accurately to define shallow longitudinal channels on opposite sides and notches at the ends for reception of the windings. In the notched ends are small metal terminal blocks 34 secured in place by rivets 35. Ivory bushings 36 and mica plates 37 insulate the blocks 34 from the rivets and bobbins. The ribbons 17 and 18 are extended into open ended key hole slots 38 in the outer ends of the blocks 34 and formed as eyes or loops in said slots whereby pins 39 may be inserted into the loops for wedging the ribbon terminals in said slots. The ends of the wire 30 of the coil are extended to and soldered on the ribbons 17 and 18 and blocks 34 at 40 and 41 respectively, said ribbons being thereby also soldered to the blocks.

It should be noted that the slots 38 of the blocks 34 are positioned so that the ribbons may be right angularly disposed as aforesaid.

Referring more specifically to the manner of individually mounting the several coil units C rela-

tive to the pole pieces D, the pole pieces on one side of the magnet are provided with rows of upstanding guide and retaining pins 42 and 43 which are respectively adapted to seat in sockets 44 and grooves 45 formed in the head pieces 13 of the several units C. Thus each unit C is guided or centered by said pins so that the sides 11 of the frame thereof will be spaced from the adjacent unit and from the walls of the opposed V-shaped recesses 9 in the pole pieces whereby the coil 16 will be centered between the pole pieces between the opposed shallow grooves 10, as shown in Fig. 4. The units C are thus subject to separate removal and replacement without disturbing the remaining units.

Each unit C has a contact plate 46 for electrically connecting the screw 20 to which the ribbon 17 is secured to the terminal block E to which circuit conductors are connected, whereby the galvanometer may be coupled with the mechanism with which it is used, for example, an oscillograph. In this connection it should be noted that the coil 16 of each coil unit is grounded through the ribbon 18, spring 27, frame 11, magnet B, housing A and ground connection G.

As shown in Fig. 8, the galvanometer of my invention may be used with a recording camera indicated by the diagrammatic showing of a film at F, positioned to receive and record the reflected light from the mirror 19 onto which light rays are cast from a light source S. Thus as the mirror 19 is vibrated the photographically recorded light rays on the film will make a graph of said vibrations.

While I have shown and described a specific embodiment of my invention I do not limit myself to the exact details of construction set forth, and the invention embraces such changes, modifications and equivalents of the parts and their formation and arrangement as come within the purview of the appended claims.

I claim:

1. In a galvanometer coil assembly, an elongated frame adapted to be positioned between pole pieces of a magnet, a wire coil, metal ribbons connected with ends of the frame for flexibly suspending said coil between them in said frame, conductor elements associated with said frame for affording the electrical connection of said coil and ribbons in an electrical circuit, a tubular torsion head adjustable on one end of said frame and to the outer end of which one end of one of said ribbons is secured after passing through the bore thereof free of contact with the walls of said bore, and means for setting said head in adjusted position.

2. In a galvanometer coil assembly, an elongated frame adapted to be positioned between pole pieces of a magnet, a wire coil, metal ribbons connected with ends of the frame for flexibly suspending said coil between them in said frame, conductor elements associated with said frame for affording the electrical connection of said coil and ribbons in an electrical circuit, said coil including an elongated longitudinally grooved bobbin having notched ends and a wire coiled therearound in the grooves thereof, terminal blocks mounted in and insulated from said notched ends of said bobbin, and having slots therein for reception of terminals of said ribbons, the wire of said coil having its ends electrically connected with said ribbons.

3. In a multiple galvanometer, a permanent magnet having opposed pole pieces, a plurality of separate galvanometer coil units, means for se-

curing said units in operative relation to and between said pole pieces in such manner that they may be selectively removed and replaced independently of one another and said pole pieces and magnet, each of said units including an elongated frame open on opposite sides, a wire coil, metal ribbons for flexibly supporting said coil between them in said frame, means affording the electrical connection of said coil and ribbons in a galva-

5 nometer circuit, said coil unit securing means including head pieces on the frames of said units having openings therein, said pole pieces having like recesses in opposed faces thereof for reception of said frames with said coils directly exposed to said pole pieces through the open sides of said frames, and pins on one of said pole pieces adapted to extend into the opening in said head pieces.

WILLIAM W. MILLER.