



INTERNATIONAL APPLICATION PUBLISHED UNDER THE PATENT COOPERATION TREATY (PCT)

<p>(51) International Patent Classification ⁶ : H01Q 1/36</p>	<p>A1</p>	<p>(11) International Publication Number: WO 97/49141 (43) International Publication Date: 24 December 1997 (24.12.97)</p>
<p>(21) International Application Number: PCT/SE97/01046 (22) International Filing Date: 13 June 1997 (13.06.97) (30) Priority Data: 9602387-4 15 June 1996 (15.06.96) SE (71) Applicant (for all designated States except US): ALLGON AB [SE/SE]; P.O. Box 500, S-184 25 Åkersberga (SE). (72) Inventor; and (75) Inventor/Applicant (for US only): WASS, Bo [SE/SE]; Örminge Gärd, Vårdsberg, S-582 95 Linköping (SE). (74) Agents: SVAHN, Stefan et al.; Axel Ehmers Patentbyrå AB, P.O. Box 10316, S-100 55 Stockholm (SE).</p>		<p>(81) Designated States: AL, AM, AT, AU, AZ, BA, BB, BG, BR, BY, CA, CH, CN, CU, CZ, DE, DK, EE, ES, FI, GB, GE, GH, HU, IL, IS, JP, KE, KG, KP, KR, KZ, LC, LK, LR, LS, LT, LU, LV, MD, MG, MK, MN, MW, MX, NO, NZ, PL, PT, RO, RU, SD, SE, SG, SI, SK, TJ, TM, TR, TT, UA, UG, US, UZ, VN, YU, ZW, ARIPO patent (GH, KE, LS, MW, SD, SZ, UG, ZW), Eurasian patent (AM, AZ, BY, KG, KZ, MD, RU, TJ, TM), European patent (AT, BE, CH, DE, DK, ES, FI, FR, GB, GR, IE, IT, LU, MC, NL, PT, SE), OAPI patent (BF, BJ, CF, CG, CI, CM, GA, GN, ML, MR, NE, SN, TD, TG). Published With international search report.</p>

(54) Title: MEANDER ANTENNA DEVICE

(57) Abstract

An antenna means for a portable radio communication device, in particular a hand-portable mobile telephone, having at least one radiating element that has a meandering and cylindrical configuration. This structure is specifically advantageous in combination with an extendable and retractable whip antenna and, when having two or more meandering radiating elements, in multi-band radiating structures. The antenna device is suitable for manufacturing in large quantities, for example by a flexible printed circuit board technique.

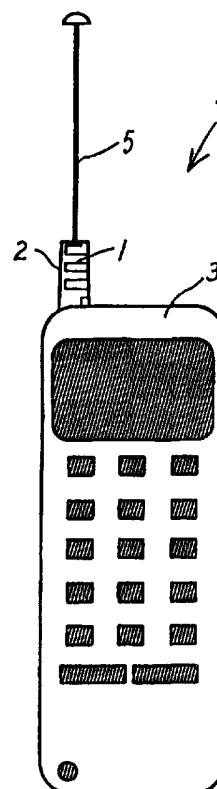

FOR THE PURPOSES OF INFORMATION ONLY

Codes used to identify States party to the PCT on the front pages of pamphlets publishing international applications under the PCT.

AL	Albania	ES	Spain	LS	Lesotho	SI	Slovenia
AM	Armenia	FI	Finland	LT	Lithuania	SK	Slovakia
AT	Austria	FR	France	LU	Luxembourg	SN	Senegal
AU	Australia	GA	Gabon	LV	Latvia	SZ	Swaziland
AZ	Azerbaijan	GB	United Kingdom	MC	Monaco	TD	Chad
BA	Bosnia and Herzegovina	GE	Georgia	MD	Republic of Moldova	TG	Togo
BB	Barbados	GH	Ghana	MG	Madagascar	TJ	Tajikistan
BE	Belgium	GN	Guinea	MK	The former Yugoslav Republic of Macedonia	TM	Turkmenistan
BF	Burkina Faso	GR	Greece	ML	Mali	TR	Turkey
BG	Bulgaria	HU	Hungary	MN	Mongolia	TT	Trinidad and Tobago
BJ	Benin	IE	Ireland	MR	Mauritania	UA	Ukraine
BR	Brazil	IL	Israel	MW	Malawi	UG	Uganda
BY	Belarus	IS	Iceland	MX	Mexico	US	United States of America
CA	Canada	IT	Italy	NE	Niger	UZ	Uzbekistan
CF	Central African Republic	JP	Japan	NL	Netherlands	VN	Viet Nam
CG	Congo	KE	Kenya	NO	Norway	YU	Yugoslavia
CH	Switzerland	KG	Kyrgyzstan	NZ	New Zealand	ZW	Zimbabwe
CI	Côte d'Ivoire	KP	Democratic People's Republic of Korea	PL	Poland		
CM	Cameroon	KR	Republic of Korea	PT	Portugal		
CN	China	KZ	Kazakstan	RO	Romania		
CU	Cuba	LC	Saint Lucia	RU	Russian Federation		
CZ	Czech Republic	LI	Liechtenstein	SD	Sudan		
DE	Germany	LK	Sri Lanka	SE	Sweden		
DK	Denmark	LR	Liberia	SG	Singapore		
EE	Estonia						

MEANDER ANTENNA DEVICE

The present invention relates to an antenna means according to the introductory portion of the appended independent claim(s).
5 Specifically, the invention concerns an antenna means for a hand-portable mobile telephone, which requires a compact and efficient antenna. The inventive antenna means is particularly advantageous when two or more radiating elements are to be combined or when an impedance matching means is required for
10 matching radiating element(s) of the antenna means to transmitter/receiver circuitry of the telephone.

A general problem when the size of an antenna radiator is reduced is a reduction in its relative bandwidth. Helically
15 configured radiators are commonly used when antennas are required to fit in confined volumes with limited height. However, the loops of a helical antenna generate a magnetic field that binds energy, which results in a further reduction of the bandwidth. Also, helical radiators have the problem of
20 strong inter-coupling when two or more radiators are arranged close to each other.

GB-A 2 280 789 discloses an antenna means having multiple turns formed by a conductive radiating element formed on a dielectric
25 substrate. The substrate may be tubular having conductive strips on one side, the strips being joined together along meeting edges of the tubular substrate. In another embodiment, the substrate is flat and has conductor strips deposited on both sides, the strips being joined together by feed-throughs
30 along opposite edges of the substrate. That prior art antenna device has the inherent drawbacks of helical antennas, and is difficult and complicated to manufacture because of the need to provide feed-throughs in the substrate or joining conductors at edges.

Although relatively efficient and compact, there is a great variety of prior art antenna devices that involve the above-mentioned problems due to the use of helical radiators. Such antenna devices are disclosed in, for example, European Patent
5 Applications published under Nos. 0 635 898 A1, 0 593 185 A1, and 0 467 822 A2, PCT Applications published under Nos. WO 94/10720 and WO 95/08199, and U.S. Patent No. 4,868,576.

In the past, meander antennas have been used when an antenna
10 device is required to have a total length which is short in relation to the wavelength at which an associated transmitter/-receiver is operated. DE-A1 31 29 045 discloses a direction finder antenna having, for example, a meander structure. A radiating element thereof has a meandering configuration and is
15 mounted on a dielectric carrier.

DE-A1 31 29 045 is considered to disclose the prior art antenna closest to the invention. The problem to be solved thereby is reducing the height of a direction finder antenna, in
20 particular to render it concealable and mobile. However, it only discloses a meander antenna which has a flat configuration. Moreover, the teachings thereof include improving the bandwidth of the antenna by using a conductor having relatively high resistance, leading to a less efficient
25 antenna. Further, there are no provisions for obtaining a mechanically durable antenna, an antenna suited to fit in a limited volume or an antenna to be combined with other types of antennas.

30 Another plane meandering antenna element is disclosed in Abstracts of Japan 60 E 1572 (publication No. 6-90108), and includes a meandering dipole and a matching means connected to a coaxial transmission line. A meandering feed arrangement for a helical antenna is disclosed in U.S. Patent No. 5,298,910. In
35 none of the latter two devices, a transmission line is connected to an end of the meandering conductor.

The pending Swedish Patent Application No. 9601706-6 includes means integrated with the antenna for matching the antenna to circuitry of a hand-portable mobile telephone. A similar
5 matching means is suitable also in the present invention. The above-mentioned Swedish Patent Application is therefore incorporated herein by this reference.

An object of the invention is to provide an efficient antenna
10 means according to the introductory portion of claim 1, which solves the problem of providing an antenna means that is mechanically durable and has a geometry suited for location in a small volume. Further objects are to provide substitutes for helical radiators which also give improved antenna performance,
15 to overcome the above-mentioned problem of binding electromagnetic energy in the radiator or radiators of the antenna means, to avoid feed-throughs in a carrier carrying the radiating element(s), to provide an efficient and cost-effective impedance matching means integrated with the antenna
20 means, to provide a configuration which is both efficient and mechanically durable, to enable the use of more precise production techniques that, e.g., wound helices, and to provide an antenna wherein different radiating elements may be combined without being adversely inter-coupled, especially wherein the
25 combination includes an extendable whip antenna.

These and other objects are attained by an antenna means according to the characterising portion of claim 1. This radiator geometry has been found to be particularly
30 advantageous with regard to stability, bandwidth and radiating properties. The radiating first element of this antenna means is a meandering conductor which is arched or bent so that it will occupy a space similar to that occupied by a helical radiating element. This configuration enables the antenna means
35 of the invention to be used in most application in radio communication devices, especially for mobile telephones, where

helical antennas have been used in the past. In comparison with a helical antenna, the advantages of using the antenna device of the invention are, for example, a greater bandwidth, improved production tolerances leading to less rejections, a lower degree of coupling to any adjacent radiators greatly improving multi-band operability, and a possibility to integrate an impedance matching network on the same carrier with at least partly the same production technique. The radiating element alternately extending in positive and negative angular directions in relation to its central axis, should be understood as including the radiating element describing a meander curve changing circumferential direction at least once in its extension along a longitudinal axis of an imaginary cylindrical shell, preferably having a circular or elliptic base.

When the antenna means includes one or more additional radiating element, operability within a wider frequency band or two or more separated frequency bands is achieved. It is possible to produce all radiating elements simultaneously in the same sequence of process steps.

When restriction of the electromagnetic energy bound in the radiating structure is specifically important, it does not include any complete turns at all and, preferably, it may only include configurations describing small fractions of a full turn around a central axis.

The first and second feed points may be interconnected and coupled in common to circuitry of the radio communication device. This could also be applied when using more than two radiating elements. Alternatively, the different radiating elements may be connected separately to the radio circuitry.

The antenna device preferably includes a dielectric carrier carrying the radiating structure to project it outwards from a

chassis of a radio communication device on which the device is to be mounted. This enables an efficient radiation pattern. The carrier is preferably a dielectric flexible film or laminate having the radiating structure applied thereon or therein in the form of a conductive film structure, possibly obtained through an etching process. A printing technique is suitable for manufacturing in large quantities.

It may be advantageous to combine the antenna means according to the invention with an extendable and retractable whip antenna, as will be appreciated from the following description of preferred embodiments. The carrier and conductors of the antenna means will then possibly include one or more switches for connecting or disconnecting different radiating elements in different operating modes.

Especially when the carrier is a flexible film with a printed circuit pattern it is advantageous to integrate on the carrier an impedance matching means for matching impedances of any radiating element on the film or in combination with that structure to circuitry of the radio communication device, usually interfacing at 50 ohms.

BRIEF DESCRIPTION OF DRAWINGS

25

Figs. 1A-B show a hand portable mobile telephone equipped with an antenna means according to various fundamentally similar embodiments of the invention, wherein a meander conductor extending in a cylindrical fashion and projecting outwards from chassis of the telephone, which is also provided with an extendable and retractable whip antenna;

Figs. 2A-C show different possible meander conductor configurations provided on a flexible film carrier in accordance with the invention;

35 Fig. 2D shows the flexible film carrier carrying the meander conductor formed into a cylindrical configuration, which could

for example be used for substituting a helical conductor in various antenna applications;

Figs. 3A-B show dual meander conductors tuned to different frequencies on common flexible film carriers providing dual
5 band operability of an antenna means according to the invention, the dual meander conductors either being fed separately or via a common feed point;

Fig. 4 shows a combination of a meander conductor having a cylindrical configuration and an extendable and retractable
10 whip antenna;

Fig. 5 shows a combination of a meander conductor having a cylindrical configuration and an extendable and retractable whip antenna, wherein a flexible film carrier of the meander conductor is provided with matching means for matching the
15 impedances of the meander conductor and the whip antenna, respectively, to an impedance on transmitter/receiver circuitry of a mobile telephone;

Fig. 6 shows another combination of a meander conductor having a cylindrical configuration and an extendable and retractable
20 whip antenna, wherein the meander conductor and the whip antenna are connected in series when the whip antenna is in its extended position;

Fig. 7 shows yet another combination of a meander conductor and an extendable and retractable whip antenna, wherein a coaxial
25 transmission line is connected to the meander conductor and the whip antenna, respectively;

Fig. 8 shows a combination of a meander conductor and an extendable and retractable whip antenna, wherein the whip antenna is in a retracted position;

30 Fig. 9 shows a slightly different combination from that in fig. 8, wherein the whip antenna is in a retracted position;

Figs. 10A-B show still another combination of a meander conductor and an extendable and retractable whip antenna, wherein a top portion of the whip antenna carries the meander
35 conductor and may or may not be conductively connected thereto.

DESCRIPTION OF PREFERRED EMBODIMENTS

With reference to fig. 1A, a meander radiating element 1 is carried by a dielectric cylindrical carrier 2 and mounted extending outwards on a chassis 3 of a hand portable mobile telephone 4. The position of the meander element 1 on the chassis 3 is selected such that radiation of the meander conductor 1 is transmitted and received effectively in different positions chosen by an operator during standby or during a telephone call. In figs. 1A-B the meander element is located at one side of a top portion of the chassis 3 projecting upwards.

Also shown in fig. 1A is an extendable and retractable whip antenna 5 shown in its extended position. There may or may not be a whip antenna combined with the meander element, depending on the antenna performance required in a specific case. Fig. 1B shows the arrangement of fig. 1A having the whip antenna in its retracted position.

20

Fig. 2A shows a first possible shape 6 of the meander radiating element being an etched conductor pattern on a dielectric flexible film carrier 7 in a flat configuration. The radiating element extends from a feed point 8 at one edge of the carrier 7, which has an essentially rectangular shape, in an alternating curve including parallel sections and semi-circular turns to a free end 9 at an opposite edge of the carrier 7. The single meander radiating element is to be formed from the flat configuration into a configuration wherein the carrier 7 is tubular or, at least forms part of a cylinder, which will be shown further below.

Fig. 2B and 2C show, with corresponding reference numerals, second and third alternative shapes 10, 11, of the meander element, including rectangular and saw tooth shapes, respectively, extending on and to be formed together with the

35

carrier 7 in a similar fashion to that of the meander element of fig. 2A.

Fig. 2D shows a preferred cylindrical configuration into which the meander element 12 and the flexible film carrier 13 are shaped together. This configuration is compact and provides high durability. It can be used in most antenna applications where essentially the space occupied by a helical antenna is available, and, in particular, when a higher performance than that of a helical radiating element is required. Alternatively the flexible film carrier could be exchanged for another dielectric carrier, preferably having a cylindrical shape with some suitable cross-section, on which a meander conductor may also be applied or developed by a high precision technique, for example etching. As seen in fig. 2A, the configuration can be said to have an imaginary central axis which the meander element 12 is arched about so that the angle relative the axis increases and decreases alternately.

With reference to fig. 3A, dual meander elements 14, 15 on a common carrier 16 are shown, which are tuned to two different frequencies allowing operation of the antenna means in two overlapping or separated frequency bands. These elements are fed by a common feed point 17 to be coupled to circuitry of a hand portable mobile telephone, possibly via an impedance matching means (not shown). It would also be possible to arrange more than two meander elements together in order to achieve operability in more than two frequency bands or still wider band(s) than could be achieved by two elements. Although depicted in a well-functioning flat configuration in fig. 3A, the flexible film carrier of the multi meander means is preferably intended to be formed in to a cylindrical configuration as described above for a single meandering element.

It can be shown by calculations and confirmed by simulations and tests, that meander elements provide a great advantage over helical elements for operation within separated or wider frequency bands, since a degree of coupling between the individual elements is much less for meander elements than for helical elements assuming the same or comparable geometrical separations.

Fig. 3B shows an alternative to the feed arrangement of fig. 3A. Here, the individual elements 18, 19 each have their own feed point 20, 19, respectively, to be coupled individually to circuitry of the telephone, possibly via an impedance matching means.

With reference to fig. 4, a combination is shown, including a cylindrically configured meander radiating element 22 carried by a cylindrical flexible film carrier 23, one point thereof being a feed point 24 and the other being a free end 25, an extendable conductive whip antenna 26 having a stopper 27 at a lower end which is adapted to contact the feed point 24 of the meander element 22 via a contact member 28 when the whip antenna 26 is extended, as is shown in fig. 4, and having at the opposite end 29 an elongated dielectric portion 30 of the whip antenna terminated by a knob 31 for holding when sliding the whip antenna 26.

The length of the elongated dielectric portion 30 is essentially equal to the length of the cylindrically configured meander element 22, so that the whip antenna 26 does not co-extend with the meander element 22 in the retracted position (indicated in fig. 8).

The radiators 22, 26 of the antenna means in fig. 4 are preferable both of the same type, e.g., half-wave or quarter-wave type.

Generally, when a higher antenna performance is required, for example during a telephone call, generally, the whip antenna will be extended and contacted via the contact member to the feed point of the meander element, so that the meander element and the whip antenna will be connected in parallel to the circuitry of the telephone. In this configuration the whip antenna effects most of the antenna function. It will also be possible to provide an antenna of this type with more complicated switching means which would completely disconnect one of the elements when not needed.

In fig. 5 there is shown schematically a general way to arrange an impedance matching means 32 integrated on a dielectric carrier 33 of the inventive antenna device. The matching means 32 is connected to a feed point 34 of a meander element 35 and includes reactive components 36, 37 (shown schematically) and connection terminals 38, 39 for signal and ground connectors (not shown) of the telephone.

The arrangement of fig. 6 includes, preferably an essentially quarter-wave meander element 40 on a cylindrical dielectric carrier 41, preferably an essentially half-wave extendable and retractable whip antenna 42 having a dielectric elongated portion 43 mounted at an upper end 44. This arrangement differs further from that of fig. 4 in that the whip antenna 42 is fed in its extended position, either conductively or capacitively, at its lower end 45 by a top portion of the meander element 40.

The arrangement of fig. 7 includes, preferably an essentially quarter-wave meander element 46 on a cylindrical dielectric carrier 47, preferably an essentially quarter-wave extendable and retractable whip antenna 48 having a dielectric elongated portion 49 mounted at an upper end 50. This arrangement differs further from that of fig. 4 in that the inner conductor 51 of a (coaxial) transmission line 51 feeds the whip antenna 48 in its extended position, either conductively or capacitively, at its

lower end 53, and a top end 54 of the meander element 46 is fed by the shield 55 of the transmission line 52, while a lower end 56 of the meander element 46 is an open end.

5 In situations where the antenna means is required to be more compact, the whip antenna 57 will be retracted as shown in fig. 8. Generally, the whip antenna 57 then provides little or none of the antenna function, while the meander element(s) 58 transmits and receives radiation power to and from the
10 telephone. Here, the dielectric portion 59 extends along the full axial length of the meander element 58, so that the whip is decoupled in the retracted position.

Alternatively, as is shown schematically in fig. 9, to reduce
15 the required receiving depth in the chassis of a hand portable mobile telephone, the whip antenna 60 may co-extend at least partially with the cylindrically configured meander element 61 even in the retracted position of the whip antenna 60. In that case the elongated dielectric portion 62 co-extends only
20 partially with the meander element 61 when the whip antenna is retracted.

Figs. 10A and 10B show in retracted and extended positions, respectively, a whip antenna 63 carrying at its top end 64 a
25 meander element 65. A conductive sleeve 66 constitutes a connection point to circuitry (or a matching means) of a telephone. Either, there is a conductive connection between the whip and meander elements, so that they together contact the sleeve 66 at the portion 64 when retracted and at a portion 67
30 when extended, or there is no conductive contact, so that the meander element 65 alone contacts the sleeve 66 in the retracted position and the antenna whip 63 alone contacts the sleeve 66 in the extended position.

Various multi-band antenna means may be constructed according to the principles described above with reference to figs. 4-10 if more than one meander element are included.

5 Although the invention has been described in conjunction with a number of preferred embodiments, it is to be understood that various modifications may still be made without departing from the spirit and scope of the invention as defined by the appended claims. One such possible modification is providing
10 the feeding means and feeding configurations differently from those shown in figs. 4-10.

CLAIMS

1. Antenna means for a portable radio communication device, comprising:

- 5 - a radiating first element tuned to a first frequency,
- the first element having a central longitudinal first axis, first and second ends being a first feed point and a first open end, respectively, and a meander configuration,

10 c h a r a c t e r i z e d b y

- the first element alternately extending in positive and negative angular directions in relation to the first axis.

15 2. Antenna means according to claim 1, further comprising:

- a radiating second element tuned to a second frequency different from the first frequency,
- the second element having a central longitudinal second axis, first and second ends being a second feed point and
20 a second open end, respectively, and a meander configuration,
- the second element alternately extending in positive and negative angular directions in relation to the second axis.

25

3. Antenna means for a portable radio communication device, comprising:

- a radiating first element tuned to a first frequency,
- the first element having a central longitudinal first
30 axis, first and second ends being a first feed point and a first open end, respectively, and a meander configuration,

c h a r a c t e r i z e d b y

- a radiating second element tuned to a second frequency
35 different from the first frequency,

- the second element having a central longitudinal second axis, first and second ends being a second feed point and a second open end, respectively, and a meander configuration,
- 5 - the antenna means being operable within first and second frequency bands surrounding the first and second frequencies, respectively.
4. An antenna means according to any preceding claim, wherein
- 10 - none of the radiating element(s) include a full turn around its central axis.
5. An antenna means according to any of claims 2-4, wherein
- the first and second feed points are interconnected.
- 15
6. Antenna means according to any preceding claim, further comprising:
- a dielectric carrier carrying the radiating element(s) and to be mounted on the radio communication device such
- 20 that the radiating element(s) projects outwards.
7. Antenna means according to claim 6, further comprising:
- the carrier having a carrier surface,
 - the radiating element(s) being formed by a conductive
- 25 film provided on the carrier surface.
8. Antenna means according to claim 6 or 7, further comprising:
- the carrier being a flexible dielectric film having thereon a printed conductive film constituting the
- 30 radiating element(s).
9. Antenna means according to claim 8, wherein
- the dielectric film has substantially the shape of a wall of a cylinder or part thereof.
- 35

10. An antenna means according to any preceding claim, wherein
- the element(s) having a meander configuration have a
shape corresponding to at least part of a wall of a
cylinder.

5

11. An antenna means according to any preceding claim, further
comprising:

- an extendable and retractable whip antenna operable in
10 combination with the element(s) having a meander
configuration.

12. An antenna means according to claim 11, wherein

- the element(s) having a meander configuration are to be
15 fixed to a chassis of a radio communication device and
through which the extendable and retractable whip antenna
is slidable,
- the elements(s) having a meander configuration are to be
coupled to circuitry of the radio communication device
20 when the whip antenna is in a retracted position,
- the whip antenna to be is coupled to the circuitry when
the whip antenna is in an extended position.

13. An antenna means according to claim 11, wherein

25 - the whip antenna is to be slidable into and out of a
chassis of a radio communication device,
- the element(s) having a meander configuration are fixed
coaxially to one end of the whip antenna and are to be
located at all times outside the chassis,
30 - the element(s) having a meander configuration are to be
coupled to circuitry of the radio communication device
when the whip antenna is in a retracted position,
- the element(s) having a meander configuration and the
whip antenna are to be coupled in series to the circuitry
35 when the whip antenna is in an extended position.

14. An antenna means according claim 11, wherein

- the whip antenna is to be slidable into and out of a chassis of a radio communication device,
- the element(s) having a meander configuration are fixed coaxially to one end of the whip antenna and are to be located at all times outside the chassis,
- the element(s) having a meander configuration are to be coupled to circuitry of the radio communication device when the whip antenna is in a retracted position,
- the whip antenna is to be coupled to the circuitry when the whip antenna is in an extended position.

15. An antenna means according to claim 11, wherein

- the element(s) having a meander configuration, preferably having essentially quarter-wave characteristics, are to be fixed to a chassis of a radio communication device and through which the extendable and retractable whip antenna, preferably having essentially half-wave characteristics, is to be slidable,
- the element(s) having a meander configuration are to be coupled to circuitry of the radio communication device when the whip antenna is in a retracted position,
- the whip antenna is to be coupled, preferably capacitively, to the circuitry via an upper portion of the element(s) having a meander configuration when the whip antenna is in an extended position.

16. An antenna means according to claim 11, wherein

- the element(s) having a meander configuration are to be fixed to a chassis of a radio communication device and through which the extendable and retractable whip antenna is to be slidable,
- the elements(s) having a meander configuration are to be coupled at an upper portion, via a transmission line extending through the elements(s) having a meander

configuration, to circuitry of the radio communication device when the whip antenna is in a retracted position,
- the whip antenna is to be coupled at a lower portion, via the transmission line, to the circuitry when the whip
5 antenna is in an extended position.

17. An antenna means according to claim 11 or 12, wherein
- the element(s) having a meander configuration are to be fixed to a chassis of a radio communication device and
10 through which the extendable and retractable whip antenna is to be slidable,
- the elements(s) having a meander configuration are to be coupled to circuitry of the radio communication device when the whip antenna is in a retracted position,
15 - the whip antenna is to be decoupled from to the circuitry and, in order to reduce an extension depth into the radio communication device, extends at least partly inside the element(s) having a meander configuration when the whip antenna is in an retracted position.

20

18. An antenna means according to any of claims 6-17, further comprising:

- integrated on the dielectric carrier an impedance matching means for matching impedance(s) of radiating
25 element(s) to circuitry of the radio communication device.

19. Antenna means according to any of claims 2-18, further comprising:

30 - at least one further radiating element having a meander configuration and being similar to the first and second elements, but tuned to a third frequency different from the first and second frequencies.

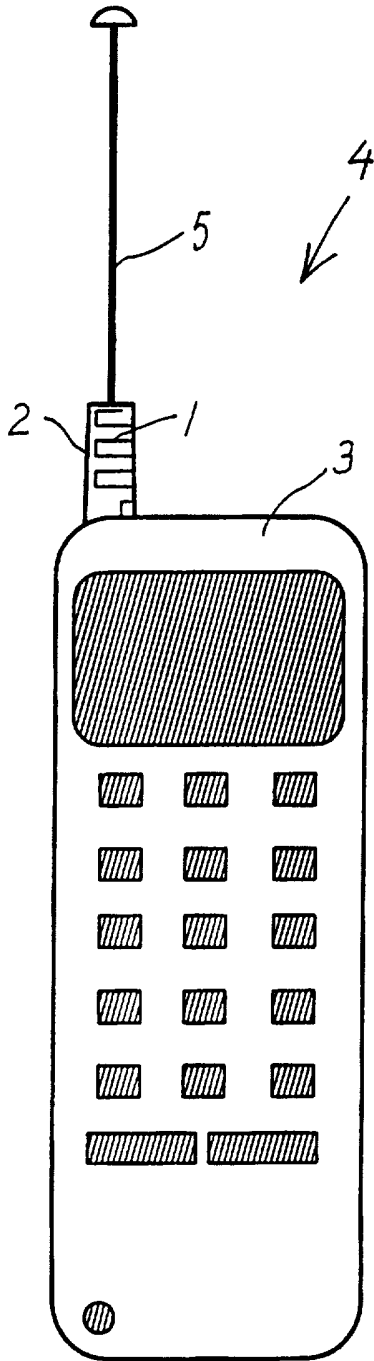

FIG. 1A

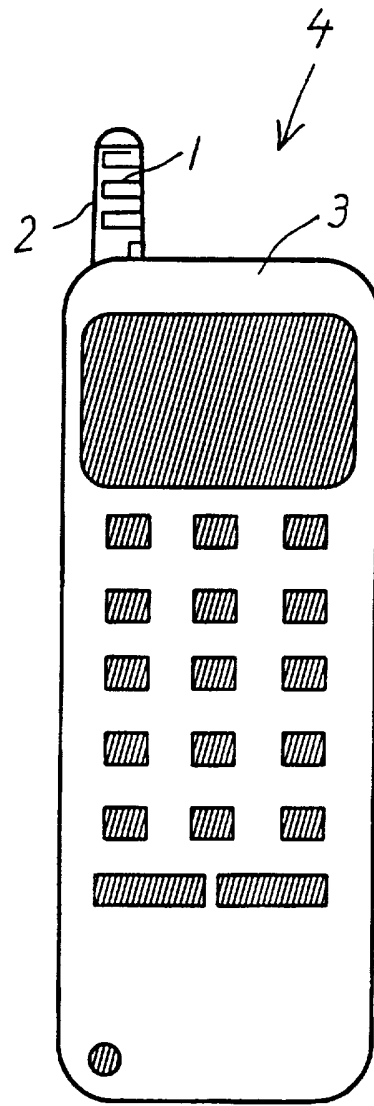
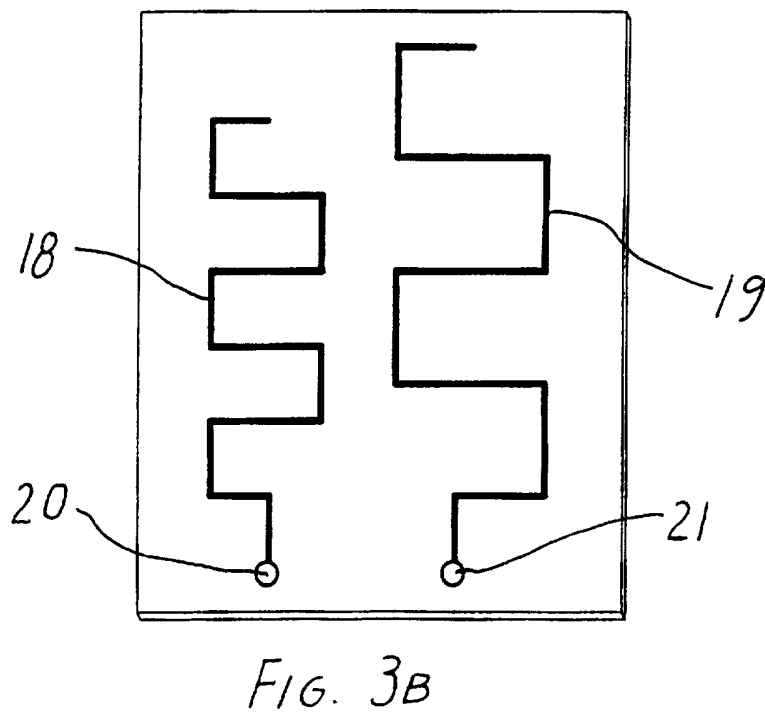
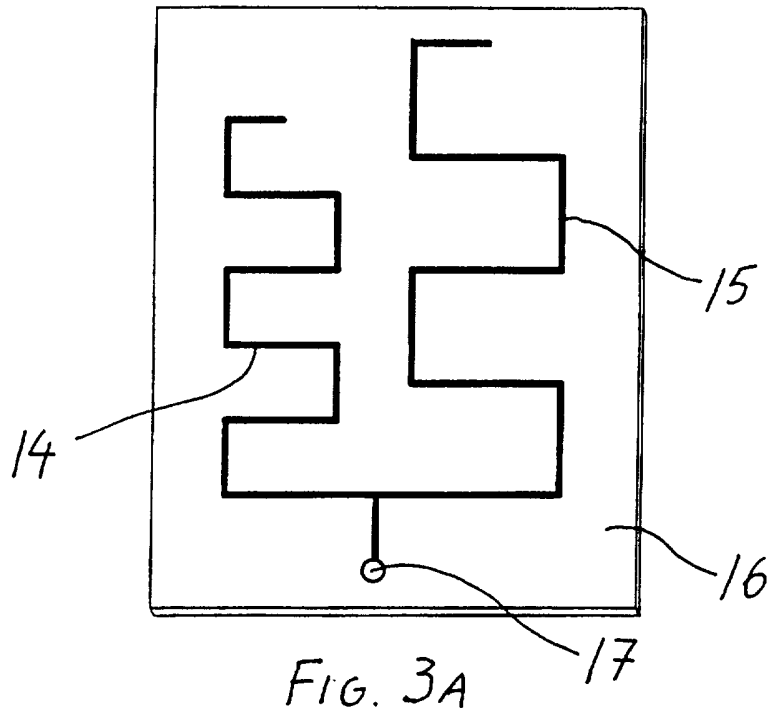
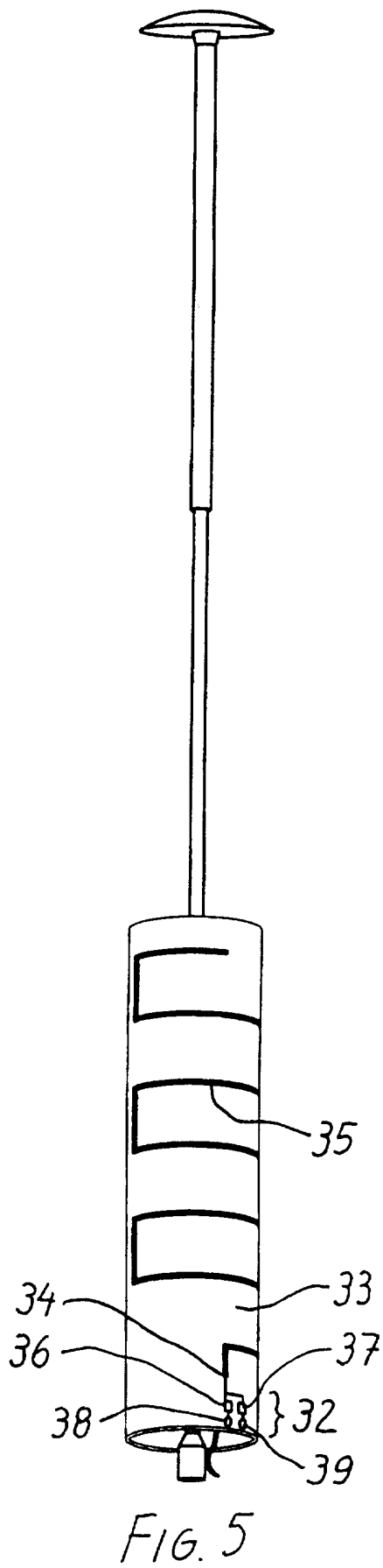
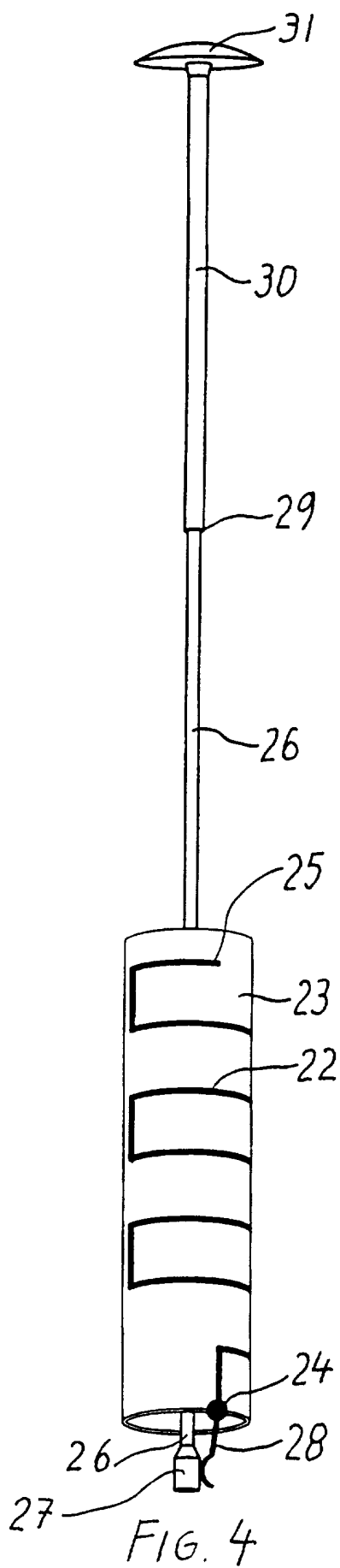

FIG. 1B





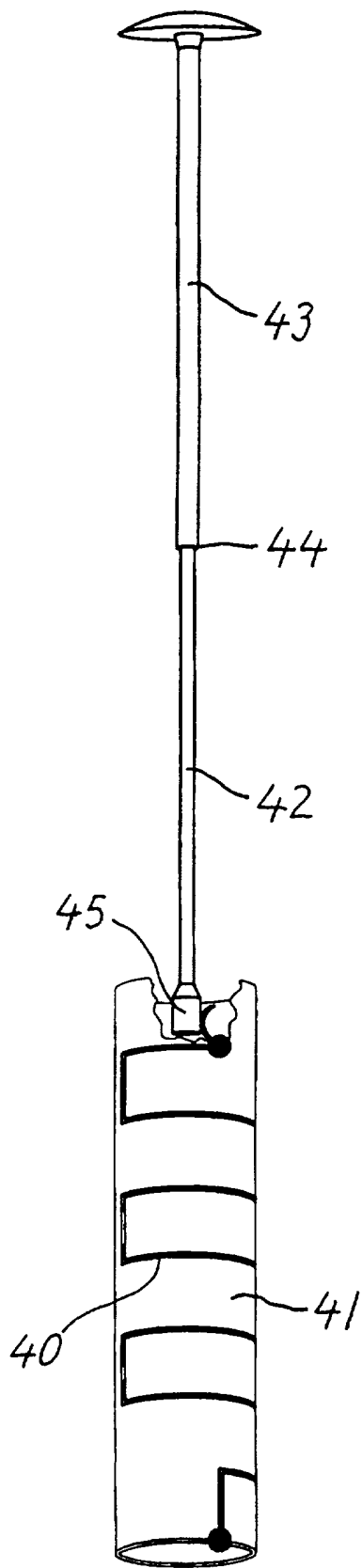

FIG. 6

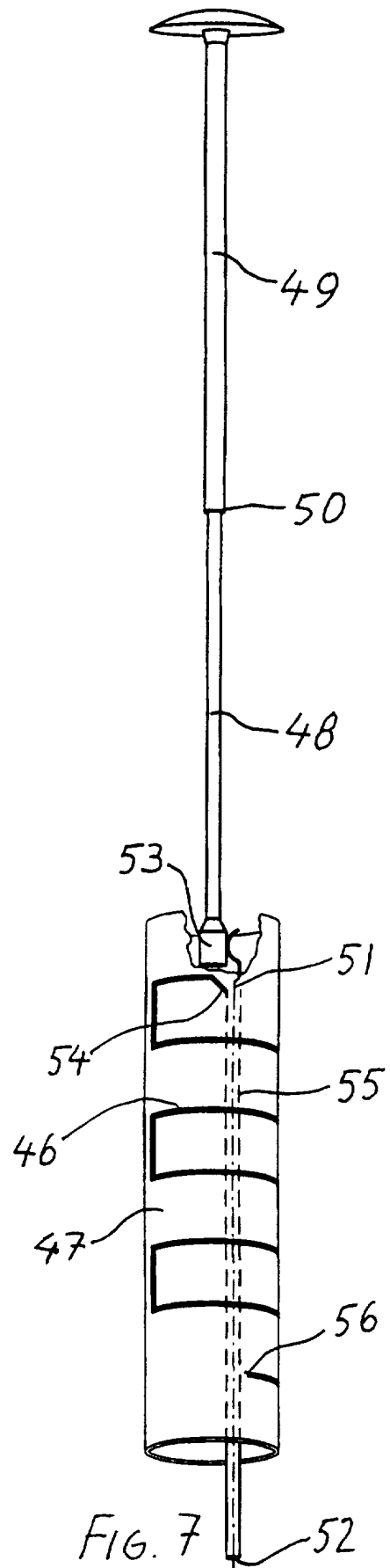

FIG. 7

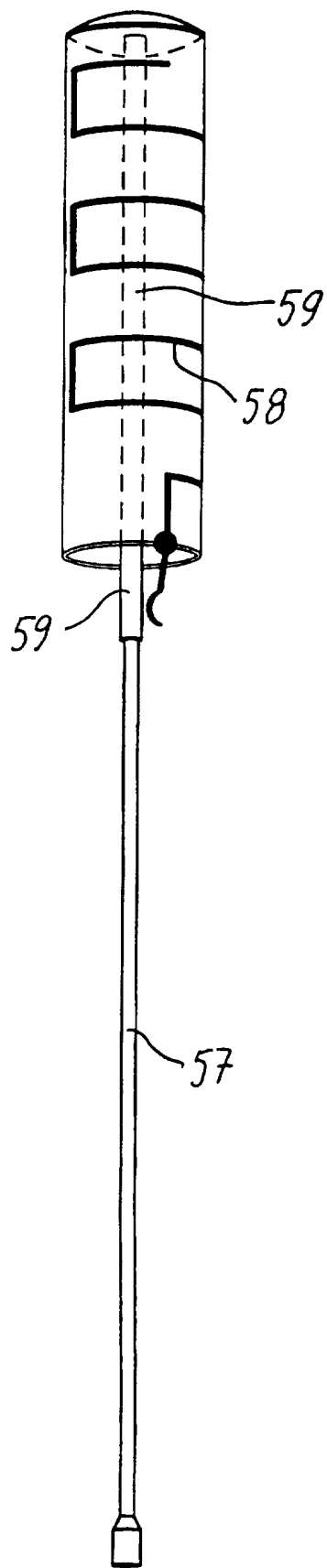

FIG. 8

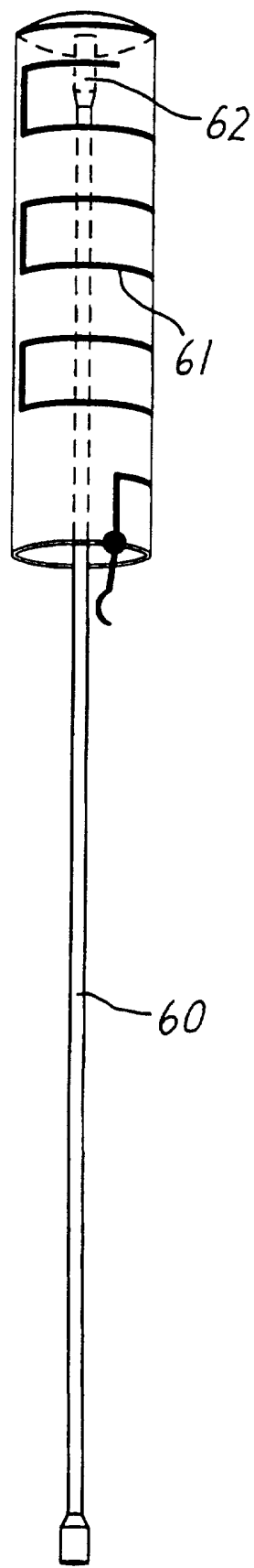
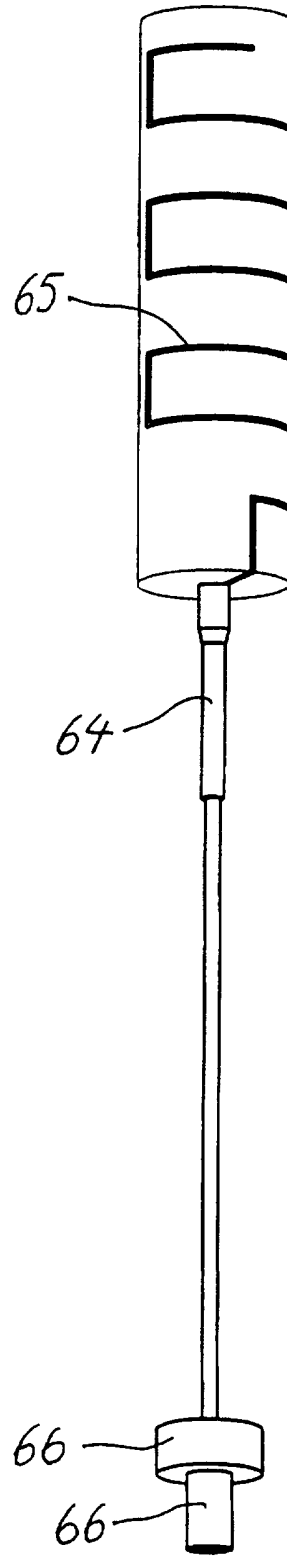
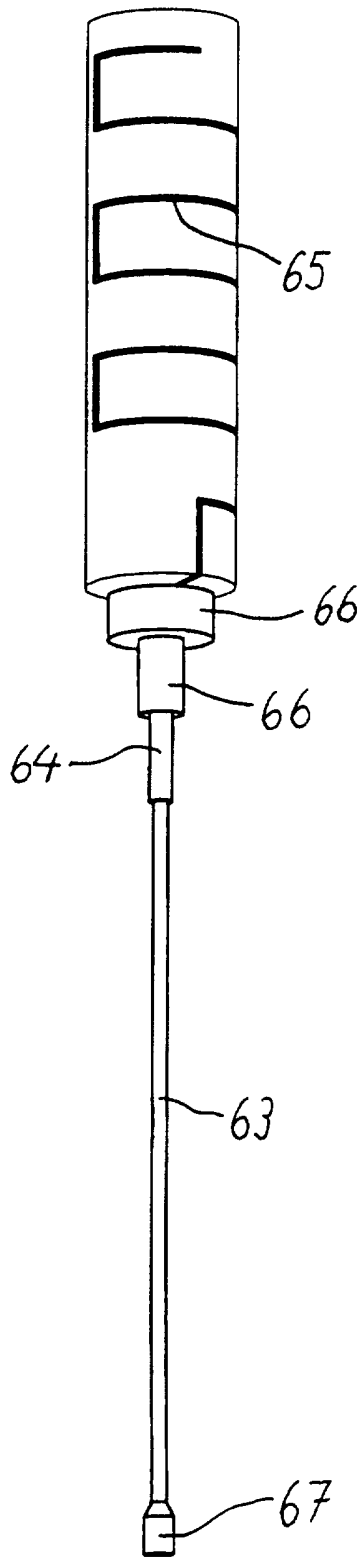

FIG. 9



INTERNATIONAL SEARCH REPORT

International application No.

PCT/SE 97/01046

A. CLASSIFICATION OF SUBJECT MATTER		
IPC6: H01Q 1/36 According to International Patent Classification (IPC) or to both national classification and IPC		
B. FIELDS SEARCHED		
Minimum documentation searched (classification system followed by classification symbols)		
IPC6: H01Q		
Documentation searched other than minimum documentation to the extent that such documents are included in the fields searched		
SE,DK,FI,NO classes as above		
Electronic data base consulted during the international search (name of data base and, where practicable, search terms used)		
C. DOCUMENTS CONSIDERED TO BE RELEVANT		
Category*	Citation of document, with indication, where appropriate, of the relevant passages	Relevant to claim No.
A	US 5298910 A (K. TAKEI ET AL), 29 March 1994 (29.03.94), cited in the application --	1-19
A	DE 3129045 A1 (C. PLATH GMBH NAUTISCH-ELEKTRONISCHE TECHNIK), 28 October 1982 (28.10.82), cited in the application --	1
A	GB 2280789 A (ANTENNA PRODUCTS LIMITED), 8 February 1995 (08.02.95), cited in the application --	2-19
<input checked="" type="checkbox"/> Further documents are listed in the continuation of Box C. <input checked="" type="checkbox"/> See patent family annex.		
* Special categories of cited documents: "A" document defining the general state of the art which is not considered to be of particular relevance "E" earlier document but published on or after the international filing date "L" document which may throw doubts on priority claim(s) or which is cited to establish the publication date of another citation or other special reason (as specified) "O" document referring to an oral disclosure, use, exhibition or other means "P" document published prior to the international filing date but later than the priority date claimed		"T" later document published after the international filing date or priority date and not in conflict with the application but cited to understand the principle or theory underlying the invention "X" document of particular relevance: the claimed invention cannot be considered novel or cannot be considered to involve an inventive step when the document is taken alone "Y" document of particular relevance: the claimed invention cannot be considered to involve an inventive step when the document is combined with one or more other such documents, such combination being obvious to a person skilled in the art "&" document member of the same patent family
Date of the actual completion of the international search		Date of mailing of the international search report
13 June 1997		26 -09- 1997
Name and mailing address of the ISA/ Swedish Patent Office Box 5055, S-102 42 STOCKHOLM Facsimile No. +46 8 666 02 86		Authorized officer Rune Bengtsson Telephone No. +46 8 782 25 00

INTERNATIONAL SEARCH REPORT

International application No.

PCT/SE 97/01046

C (Continuation). DOCUMENTS CONSIDERED TO BE RELEVANT		
Category*	Citation of document, with indication, where appropriate, of the relevant passages	Relevant to claim No.
A	EP 0635898 A1 (ERICSSON GE MOBILE COMMUNICATIONS INC.), 25 January 1995 (25.01.95), cited in the application ----- -----	2-19

INTERNATIONAL SEARCH REPORT

Information on patent family members

01/09/97

International application No.

PCT/SE 97/01046

Patent document cited in search report	Publication date	Patent family member(s)	Publication date
US 5298910 A	29/03/94	JP 4287505 A US 5559524 A	13/10/92 24/09/96
DE 3129045 A1	28/10/82	NONE	
GB 2280789 A	08/02/95	NONE	
EP 0635898 A1	25/01/95	CN 1102509 A FI 943339 A JP 7154121 A SE 9302420 A	10/05/95 15/01/95 16/06/95 15/01/95