



US00D494530S1

(12) **United States Design Patent**  
**Fraser**

(10) **Patent No.:** **US D494,530 S**

(45) **Date of Patent:** **\*\* Aug. 17, 2004**

(54) **AIRCRAFT**

D484,451 S \* 12/2003 Fraser ..... D12/319

\* cited by examiner

(76) **Inventor:** **Norman Thomas Laurence Fraser,**  
4597 Candleberry Ave., Seal Beach, CA  
(US) 90740-3026

*Primary Examiner*—Marcus A. Jackson

(\*\*) **Term:** **14 Years**

(57) **CLAIM**

The ornamental design for an aircraft, as shown and described.

(21) **Appl. No.:** **29/194,373**

(22) **Filed:** **Nov. 24, 2003**

(51) **LOC (7) Cl.** ..... **12-99**

(52) **U.S. Cl.** ..... **D12/319**

(58) **Field of Search** ..... D12/319-345;  
244/45 A, 45 R, 13, 15, 55, 91, 199

**DESCRIPTION**

FIG. 1 is a left side perspective view of a first four engine embodiment of an aircraft showing my new design.

FIG. 2 is a left side elevation view thereof.

FIG. 3 is a front elevational view thereof. This view also applies to my second four engine aircraft.

FIG. 4 is a top plan view thereof.

FIG. 5 is a left side perspective view of a second four engine embodiment of an aircraft showing my new design.

FIG. 6 is a left side elevational view thereof; and,

FIG. 7 is a top plan view thereof.

(56) **References Cited**

**U.S. PATENT DOCUMENTS**

D370,456 S \* 6/1996 Buchsel et al. .... D12/319

D451,879 S \* 12/2001 Fraser ..... D12/319

D453,014 S \* 1/2002 Fraser ..... D12/319

**1 Claim, 3 Drawing Sheets**

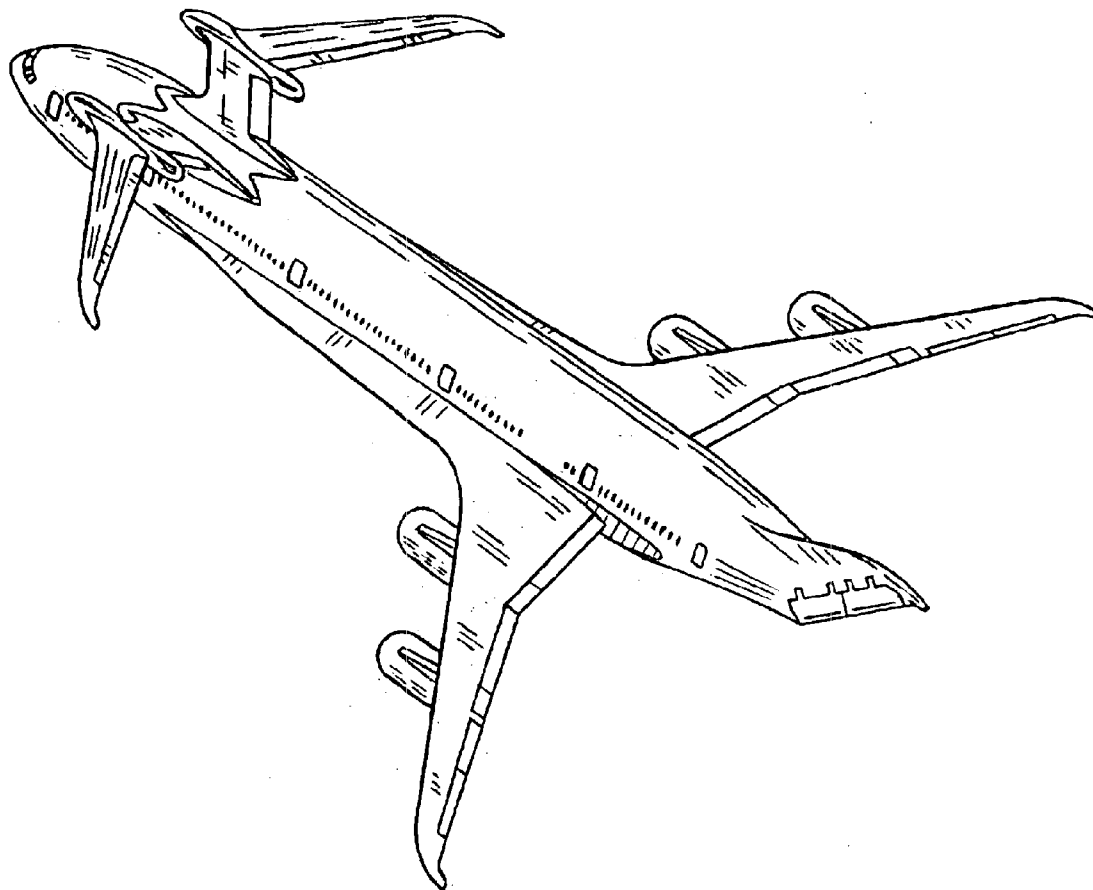

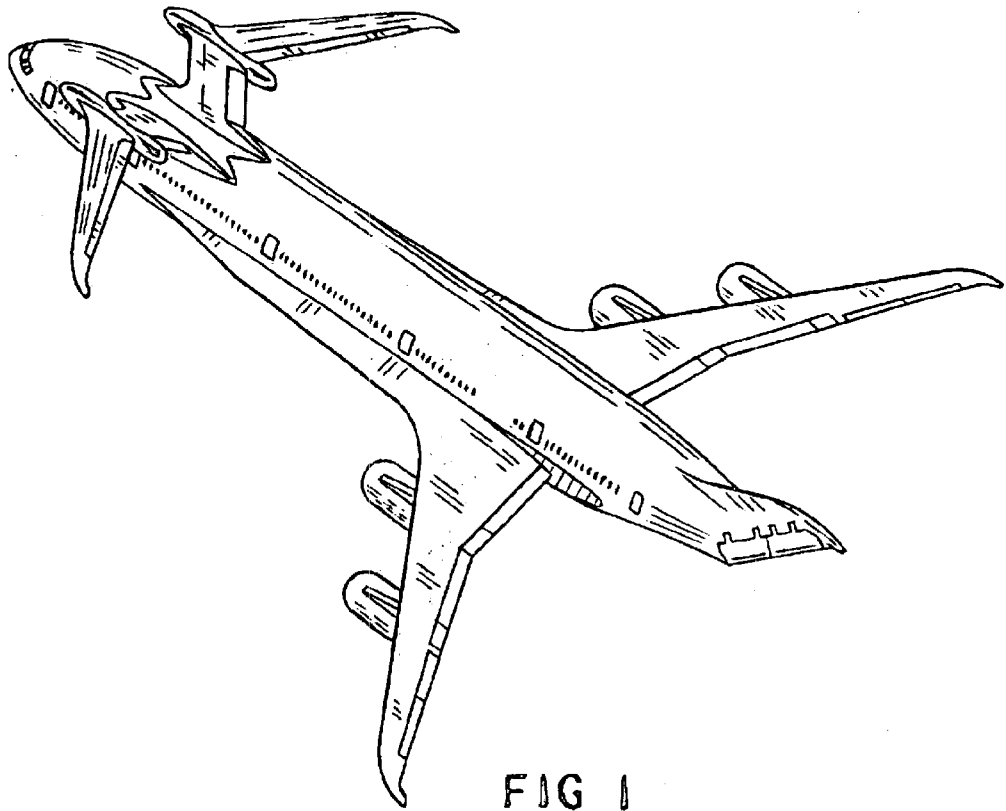

FIG 1

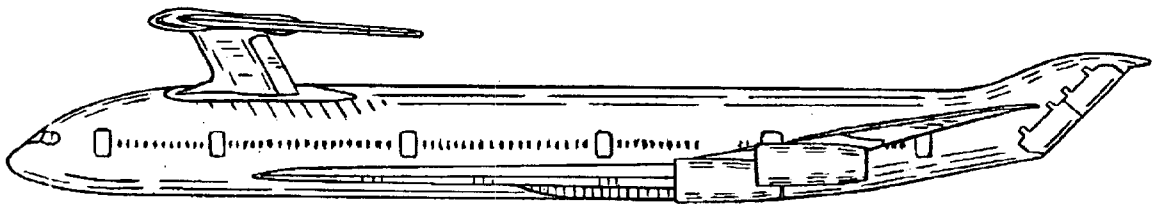

FIG 2

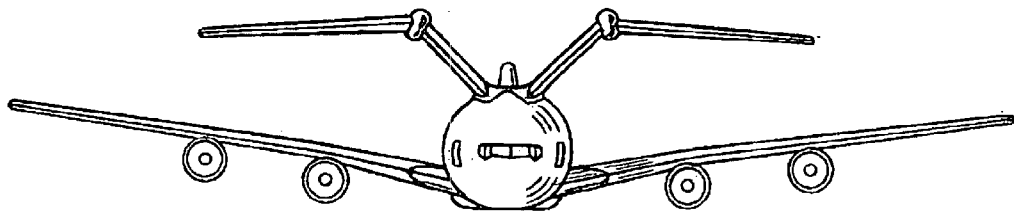
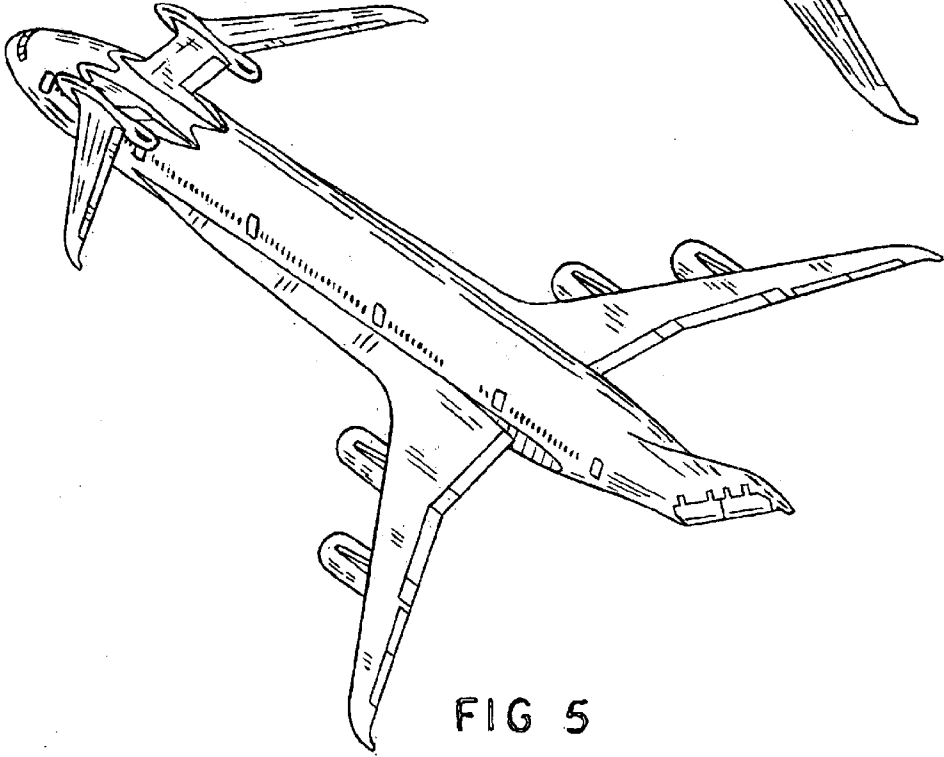
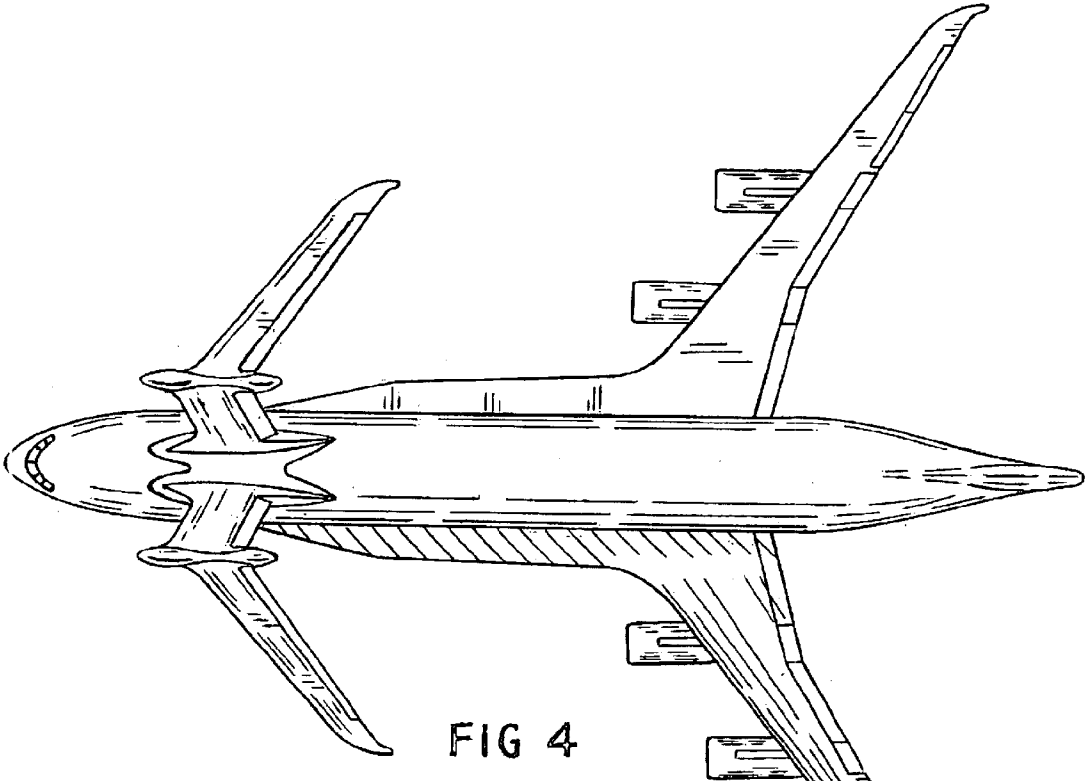

FIG 3



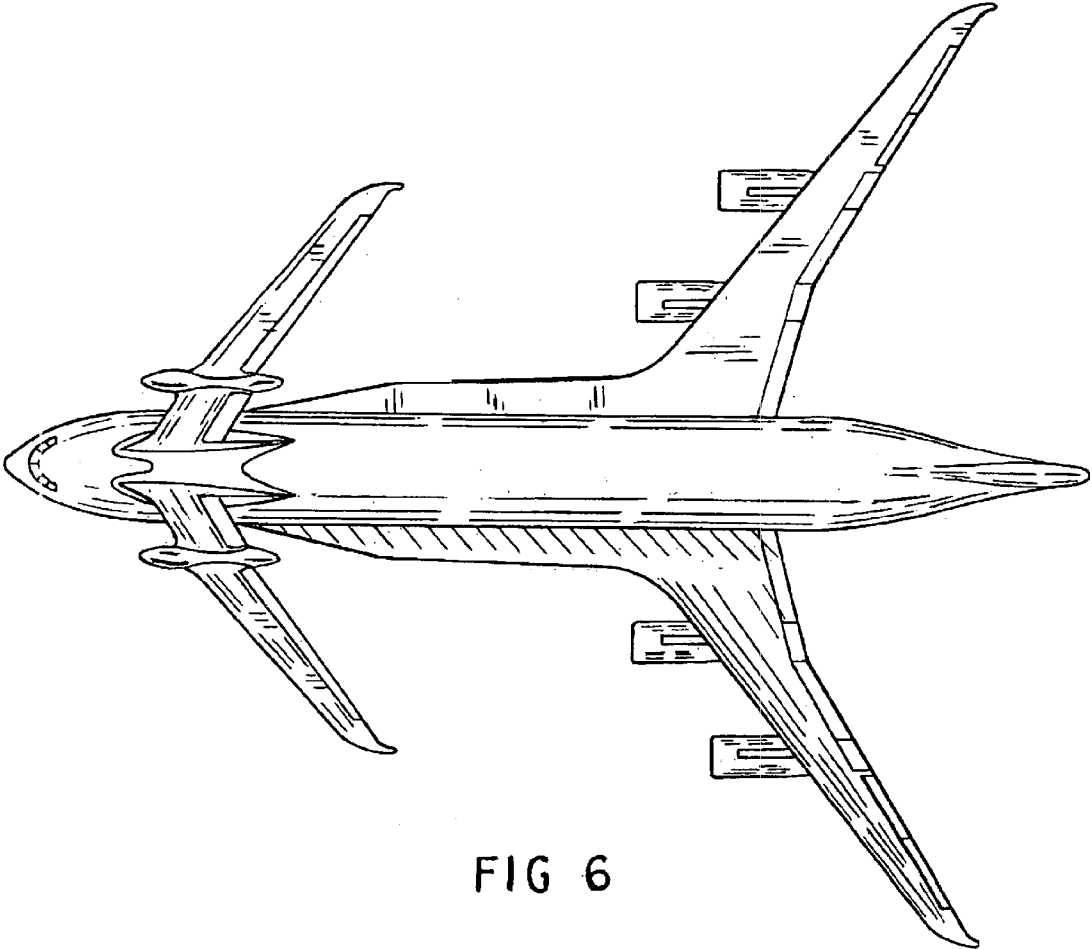

FIG 6

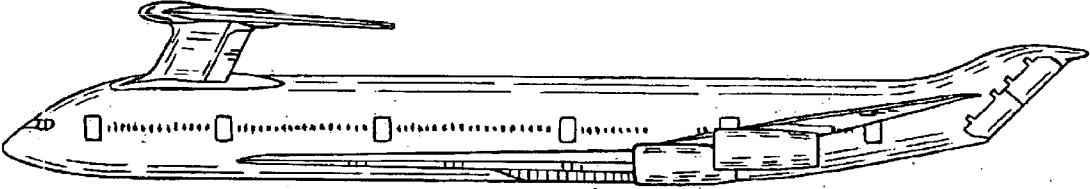

FIG 7