



(51) International Patent Classification:

A61B 17/16 (2006.01) A61B 17/32 (2006.01)
A61B 17/34 (2006.01) A61B 18/12 (2006.01)

(21) International Application Number:

PCT/US2015/040867

(22) International Filing Date:

17 July 2015 (17.07.2015)

(25) Filing Language:

English

(26) Publication Language:

English

(30) Priority Data:

62/031,037 30 July 2014 (30.07.2014) US
62/043,537 29 August 2014 (29.08.2014) US
62/135,791 20 March 2015 (20.03.2015) US

(71) Applicant: MEDOVEX CORP. [US/US]; 1735 Buford Hwy., Suite 215-113, Cumming, Georgia 30041 (US).

(72) Inventors: CARTER, Robert D.; 14384 Excelsior Lane, Apple Valley, Minnesota 55124 (US). GULLICKSON, Adam L.; 709 Hickory St. W., Stillwater, Minnesota 55082 (US). HAUFE, Scott M.W.; 302 Olde Post Road,

Niceville, Florida 32578 (US). IVERSON, Seth; 310 Foster Ave., Carver, Minnesota 55315 (US). BLANK, Jacob; 2516 Dupont Ave. S., Unit #3, Minneapolis, Minnesota 55405 (US). ZORAN, Arik; 2690 Meadow Wood Dr., Clearwater, Florida 33761 (US).

(74) Agent: RICHARDSON, Julie H.; Myers Bigel Sibley & Sajovec, P.A., P.O. Box 37428, Raleigh, North Carolina 27627 (US).

(81) Designated States (unless otherwise indicated, for every kind of national protection available): AE, AG, AL, AM, AO, AT, AU, AZ, BA, BB, BG, BH, BN, BR, BW, BY, BZ, CA, CH, CL, CN, CO, CR, CU, CZ, DE, DK, DM, DO, DZ, EC, EE, EG, ES, FI, GB, GD, GE, GH, GM, GT, HN, HR, HU, ID, IL, IN, IR, IS, JP, KE, KG, KN, KP, KR, KZ, LA, LC, LK, LR, LS, LU, LY, MA, MD, ME, MG, MK, MN, MW, MX, MY, MZ, NA, NG, NI, NO, NZ, OM, PA, PE, PG, PH, PL, PT, QA, RO, RS, RU, RW, SA, SC, SD, SE, SG, SK, SL, SM, ST, SV, SY, TH, TJ, TM, TN, TR, TT, TZ, UA, UG, US, UZ, VC, VN, ZA, ZM, ZW.

(84) Designated States (unless otherwise indicated, for every kind of regional protection available): ARIPO (BW, GH,

[Continued on next page]

(54) Title: SURGICAL TOOLS FOR SPINAL FACET THERAPY TO ALLEVIATE PAIN AND RELATED METHODS

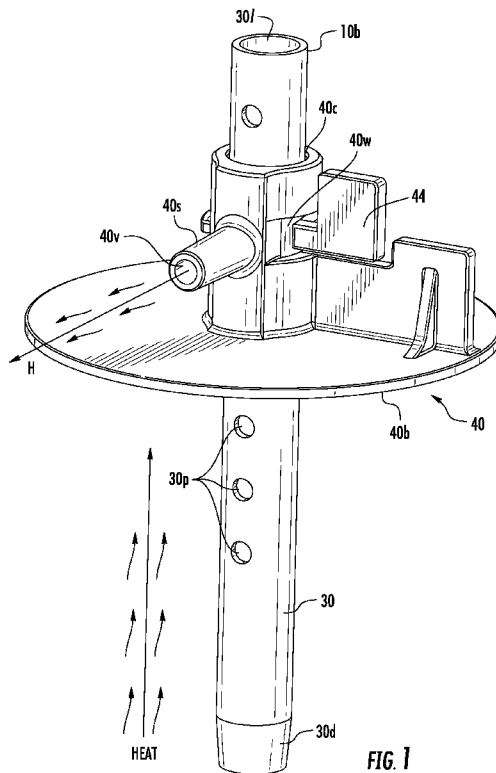

(57) Abstract: Methods and surgical tools for treating back pain using a spinal facet debridement tool with cautery and denuding action and a minimally invasive protocol that can denude and cauterize soft tissue associated with a synovial capsule of the spinal facet joint.

WO 2016/018643 A1



GM, KE, LR, LS, MW, MZ, NA, RW, SD, SL, ST, SZ, TZ, UG, ZM, ZW), Eurasian (AM, AZ, BY, KG, KZ, RU, TJ, TM), European (AL, AT, BE, BG, CH, CY, CZ, DE, DK, EE, ES, FI, FR, GB, GR, HR, HU, IE, IS, IT, LT, LU, LV, MC, MK, MT, NL, NO, PL, PT, RO, RS, SE, SI, SK, SM, TR), OAPI (BF, BJ, CF, CG, CI, CM, GA, GN, GQ, GW, KM, ML, MR, NE, SN, TD, TG).

Published:

- *with international search report (Art. 21(3))*
- *before the expiration of the time limit for amending the claims and to be republished in the event of receipt of amendments (Rule 48.2(h))*

ATTORNEY DKT Number 1179-4WO

SURGICAL TOOLS FOR SPINAL FACET THERAPY TO ALLEVIATE PAIN AND RELATED METHODS

Related Applications

[0001] This application claims the benefit of and priority to U.S. Provisional Patent Application Serial Number 62/031,037 filed July 30, 2014, U.S. Provisional Patent Application Serial Number 62/043,537 filed August 29, 2014, and U.S. Provisional Patent Application Serial Number 62/135,791 filed March 20, 2015, the contents of which are hereby incorporated by reference as if recited in full herein.

Field of the Invention

[0002] The present invention relates to spinal medical procedures.

Background

[0003] The facet joint is unique in that it has innervations via a single nerve source. For many years, a process of facet joint rhizotomy (RFL) has been utilized to provide temporary relief of spinal arthritis pain. RFL procedures involve cryotherapy or radiofrequency techniques to either freeze or burn the nerve. RFL is temporary because the nerve is destroyed at a point between the dorsal root ganglion (the nerve cell's body) and the end plate receptors (pain stimulation points on the joint) and thus, like any peripheral nerve, the nerve gradually regenerates and the pain eventually returns. Most RFL procedures last between 4 and 8 months and must be repeated when the pain returns for the rest of the patient's life for effective pain relief. Another option involves spinal fusion which is an expensive and relatively complex surgery with a success rate of only around 50% for spinal arthritis and few spine surgeons would perform such a surgery for spinal arthritis. Spinal fusion involves inserting rods and screws into the spine to permanently lock the joints.

[0004] Alternatively, upon proper training, a facet treatment (which can be described as a debridement procedure) can be performed on a cervical, thoracic or lumbar facet joint of a human spine. During facet debridement, the synovial capsule between facets is removed so as to denude the bone and denervate the joint (preventing reinnervation).

[0005] In the past, it is believed that only a few surgeons have been able to carry out a facet debridement procedure. The procedure was carried out using a plurality of separate instruments including a long wire hand burr to denude tissue and a cauterization tool to

cauterize remaining tissue. Cauterization may be needed to stop bleeding, to prevent re-growth of removed tissue, and/or for other purposes. This often means that a surgeon must revisualize the operative site after changing instruments and locate the area to be cauterized. This can be especially problematic in laparoscopic procedures. Specifically, the surgeon must remove the grinder or other mechanical cutting instrument from a cannula, insert a cauterization instrument, and then cauterize the appropriate region.

Summary of Embodiments of the Invention

[0006] Embodiments of the present invention provide relatively rapid, minimally invasive and cost effective treatments for long term, typically permanent, pain relief for spinal arthritis pain.

[0007] Some embodiments are directed to methods of minimally invasively treating a patient for back pain, including, for example spinal facet arthritis.

[0008] The method can be carried out as an outpatient procedure.

[0009] Embodiments of the invention provide surgical systems with a guide cannula having at least one exhaust port and a hand grip member that is attached to the guide cannula (integrally or releasably attached) to allow for a twist and push action of the guide cannula.

[0010] The target spinal facet joint can be a lumbar spinal facet joint and the cannula and debrider tool can extend out of the patient at an angle of between about 10-40 degrees laterally, perpendicular to the target spinal facet joint.

[0011] The target spinal facet joint can be a cervical or thoracic spinal facet joint and the cannula and debrider tool can extend out of the patient at an angle of between about 0-10 degrees laterally, perpendicular to the target spinal facet joint.

[0012] Systems for the therapy can include an electrocautery generator that operates with a power curve having a maximum wattage of 50 Watts, typically about 40Watts.

[0013] Embodiments of the invention are directed to methods of minimally invasively treating a patient for back pain. The methods include: (a) introducing a guide cannula into the patient so that a distal end resides proximate a target spinal facet joint; (b) attaching the guide cannula to an external stabilizer before, during or after the introducing step; then (c) denuding and cauterizing soft tissue at the target spinal facet joint, serially or concurrently, using a tool with a denuding and cauterization head that extends through the guide cannula. The denuding is carried out by rotating the head of the tool to remove an end plate receptor region comprising the synovial capsule of the spinal facet joint thereby treating back pain.

The method also includes (d) suctioning fluid from the guide cannula and out of a vacuum port in the stabilizer during the cauterizing to exhaust heat generated from the cauterizing.

[0014] The guide cannula can have a plurality of longitudinally spaced apart heat exhaust ports, the method further comprising aligning a selected guide cannula heat exhaust port with the stabilizer vacuum port before or during the attaching step.

[0015] The attaching can be carried out to lockingly engage an external portion of the guide cannula at a desired user adjustable height to position a distal end of the guide cannula at the target spinal facet joint before the denuding and cauterizing is carried out.

[0016] The introducing step can be carried out by concurrently manually rotating and pushing the guide cannula inward toward the target spinal facet joint over a dilation tube to position the distal end of the guide cannula proximate the target spinal facet joint before the denuding and cauterizing.

[0017] The method can include concurrently rotating and pushing the guide cannula inward toward the target spinal facet joint before attaching the guide cannula to the external stabilizer.

[0018] The concurrent rotating and pushing can be carried out using a hand grip attached to an external portion of the guide cannula.

[0019] The introducing step can be carried out by first inserting a k-wire or pin into the patient into bone at the target spinal facet joint, then inserting a dilation tube over the k-wire or pin into the patient, then inserting the guide cannula over the dilation tube. A hand grip can be attached to the guide cannula before, during or after the guide cannula is inserted over the dilation tube so that the dilation tube and k-wire or pin extend out of the hand grip above the guide cannula. Then a user can concurrently rotating and pushing inward against the hand grip to cut through tissue adjacent the target spinal facet joint and thereby position a distal end of the guide cannula at the target spinal facet joint.

[0020] The introducing step can visually confirm the guide cannula is in a desired location by referring to visual guide marks on the k-wire or pin above the hand grip.

[0021] The method can include, before the cauterizing and denuding, connecting the tool to an electrosurgical generator with an RF source. The cauterizing can be carried out using a power curve with a maximum output wattage of 50 Watts, a maximum current of 1000 mA, and a maximum voltage in a range of 180V and 220 V.

[0022] The power curve for the electrosurgical generator can have a maximum output wattage of 40 Watts, a maximum current of 1000 mA, and a maximum voltage in a range of 180 V and 220 V (optionally with an ohmic range of 0-3000 ohms).

[0023] Yet other embodiments are directed to methods of minimally invasively treating a patient for back pain by denuding a target spinal facet joint using a combination cautery and denuding tool. The denuding is carried out by rotating a head of the tool at a rotational speed of between 10 and 5000 rotations per minute to remove an end plate receptor region with the synovial capsule of the spinal facet joint thereby treating back pain. The method can include cauterizing the target spinal facet joint, serially or concurrently with the denuding, using the combination cautery and denuding tool connected to an electrosurgical generator having a power curve with a maximum output wattage of 40 Watts, a maximum current of 1000 mA, and a maximum voltage in a range of 180V and 220 V. The method can include suctioning heat during at least the cauterizing to exhaust heat generated from the cauterizing.

[0024] Yet other embodiments are directed to surgical tools for spinal facet surgical procedures for alleviating spinal pain. The surgical tools include a guide cannula with a wall surrounding a cylindrical channel, the wall having a plurality of longitudinally spaced apart fluid ports extending therethrough. The surgical tools also include an external stabilizer with a base configured to rest against skin of a patient. The base holds a tube that extends outward above the base and comprises at least one vacuum port. The tube releasably engages the guide cannula. When assembled, the stabilizer at least one vacuum port is in fluid communication with at least one of the guide cannula fluid ports.

[0025] The tube that extends outward from the base can hold an arm that extends perpendicularly outward from an axial direction of the tube about the vacuum port. The arm can releasably attach to a conduit which engages a vacuum source.

[0026] The guide cannula fluid ports can be heat exhaust ports and/or can remain closed until selectively opened by a user.

[0027] The plurality of longitudinally spaced apart fluid ports can be between 3-10.

[0028] The longitudinally spaced apart fluid ports can be in-line.

[0029] The arm of the tube held by the base that connects to a vacuum source can have a length that is between 1 and 3 inches.

[0030] The surgical tools can include a hand grip member configured to attach to the guide cannula to thereby allow a user to concurrently rotate and push against the guide cannula.

[0031] The hand grip member can have an open center channel extending therethrough with a circumferentially extending stop surface that releasably engages a proximal end of the guide cannula.

[0032] The hand grip member can include a longitudinally extending recess that slidably engages a longitudinally extending protrusion on the guide cannula. The longitudinally extending guide protrusion can hold the longitudinally spaced apart fluid ports.

[0033] The surgical tools can include a k-wire or guide pin that has visual markings thereon for allowing a user to determine a depth of a distal end of the guide cannula relative to the k-wire or guide pin when the k-wire or guide pin is in bone at a target spinal facet joint.

[0034] Yet other embodiments are directed to surgical tools that include an external stabilizer configured with a bottom surface that resides against skin of a patient. The stabilizer has an upwardly extending tube with a through channel that is held by the base and the tube has a wall that includes a vacuum port extending therethrough. The tube that extends upwardly from the base can hold an arm that extends perpendicularly outward from an axial direction of the tube about the vacuum port. The arm is adapted to attach to a vacuum source.

[0035] The surgical tool can be used in combination with a guide cannula. The guide cannula can have a cylindrical wall that surrounds an open through-channel. The wall can include a plurality of longitudinally spaced apart ports extending through the wall. The stabilizer can be sized and configured to releasably hold the guide cannula while allowing the guide cannula to align at least one of the guide cannula ports with the stabilizer tube vacuum port. The bottom surface of the stabilizer can have a perimeter with a width that is between about 2-6 inches.

[0036] The surgical tool can be used in combination with a hand grip that detachably engages the guide cannula. The hand grip can have an open center channel that is concentric with the guide cannula channel.

[0037] Still other embodiments are directed to surgical tools for spinal facet therapies. The tools include a housing, an electric motor in the housing, and a shaft held by the housing that rotates to turn a cautery and denudement head at a low speed. The shaft has a head with a linear cautery element and first and second diametrically opposing tissue scraping members that face each other across the linear cautery element. The tools also include a connector that electrically connects the cautery and denudement head to a power source and a circuit in the housing configured to carry out one or both of: (i) monitor wattage supplied by the cautery source to inhibit or prevent operation if wattage is above 50 Watts; and/or (ii) destroy or disengage one or more components of the tool based on a defined triggering event to inhibit re-use.

[0038] Yet other embodiments are directed to spinal facet therapy systems. The systems include an electrosurgical generator having a defined operational power curve with a maximum wattage of 60 Watts and a spinal facet therapy tool with an elongate rotatable shaft. The shaft has a distal end with a cautery element. The tool is in communication with the electrosurgical generator and is configured to automatically rotate at between about 10 rpm to about 5000 rpm to remove an end plate receptor region with the synovial capsule of the spinal facet joint. The electrosurgical generator supplies power to the cautery element while the shaft rotates or is stationary. The system also includes a guide cannula with at least one fluid port extending through a longitudinally extending wall thereof, the guide cannula configured to hold the tool shaft during an active treatment. The system also includes a stabilizer residing against skin of a patient and holding the guide cannula therein during the active treatment. The stabilizer includes at least one vacuum port in fluid communication with the guide cannula at least one fluid port and a vacuum source to thereby suction heat from the guide cannula when the cautery element is cauterizing.

[0039] The tool can have an onboard electrical motor. The electrosurgical generator can include a Field-Programmable Gate Array (FPGA) architecture for controlling output based on the defined power curve.

[0040] The electrosurgical generator can be held in a housing that also holds a power source for the motor.

[0041] The power curve can have a maximum output wattage of 50 Watts, a maximum current of 1000 mA, and a maximum voltage in a range of 180V-220 V.

[0042] The power curve can have a maximum output wattage of 40 Watts, a maximum current of 1000 mA, and a maximum voltage of 180V- 220 V (optionally with an ohmic range some or all of 0-3000 ohms).

[0043] The spinal therapy system can include a hand grip member that can be configured to detachably couple to the guide cannula to thereby allow a user to concurrently rotate and push against the guide cannula to place the guide cannula in a desired position prior to inserting the tool shaft into the guide cannula.

[0044] The hand grip member can have an open center channel extending therethrough with a circumferentially extending stop surface that releasably engages a proximal end of the guide cannula.

[0045] The hand grip member can include a longitudinally extending recess that slidably engages a longitudinally extending protrusion on the guide cannula. The

longitudinally extending guide cannula protrusion can hold the longitudinally spaced apart fluid ports.

[0046] The spinal therapy system can include a k-wire or guide pin that has visual markings thereon for allowing a user to determine a depth of a distal end of the guide cannula relative to the k-wire or guide pin when the k-wire or guide pin is in bone at a target spinal facet joint.

[0047] The cautery element can be or comprise a linear cautery element that extends straight across a distal face of the distal end of the shaft. The distal end of the shaft can also include first and second diametrically opposing tissue scraping members that face each other across the linear cautery element.

[0048] It is noted that aspects of the invention described with respect to one embodiment, may be incorporated in a different embodiment although not specifically described relative thereto. That is, all embodiments and/or features of any embodiment can be combined in any way and/or combination. Applicant reserves the right to change any originally filed claim or file any new claim accordingly, including the right to be able to amend any originally filed claim to depend from and/or incorporate any feature of any other claim although not originally claimed in that manner. These and other objects and/or aspects of the present invention are explained in detail in the specification set forth below.

[0049] Other systems and/or methods according to embodiments of the invention will be or become apparent to one with skill in the art upon review of the following drawings and detailed description. It is intended that all such additional systems, methods, and/or devices be included within this description, be within the scope of the present invention, and be protected by the accompanying claims.

Brief Description of the Drawings

[0050] Other features of the present invention will be more readily understood from the following detailed description of exemplary embodiments thereof when read in conjunction with the accompanying drawings.

[0051] **Figure 1** is a side view of a guide cannula held by a cooperating stabilizer according to embodiments of the present invention.

[0052] **Figure 2** is a schematic illustration of a guide cannula and stabilizer in line with a target spinal facet joint, with a combination tissue removal (denudement) and cauterization tool inserted according to embodiments of the present invention.

[0053] **Figure 3** is a side view of a surgical tool for spinal facet pain alleviation therapies according to embodiments of the present invention.

[0054] **Figure 4A** is an enlarged side perspective views of an exemplary external stabilizer holding an exemplary guide tube, shown with the stabilizer with a transparent body/wireframe to illustrate the underlying guide tube according to embodiments of the present invention.

[0055] **Figure 4B** is a front view of the device shown in **Figure 4A**.

[0056] **Figure 4C** is a front view of the device shown in **Figures 4A** and **4B** but with the stabilizer shown in solid.

[0057] **Figure 4D** is a corresponding enlarged side perspective view of the device shown in **Figure 4C**.

[0058] **Figure 5A** is a schematic illustration of a guide tube with a cover over the vacuum ports according to embodiments of the present invention.

[0059] **Figures 5B-5D** schematically illustrates optional piercing elements that may be provided to open closed guide cannula fluid ports according to embodiments of the present invention.

[0060] **Figure 6A** is a side perspective view of a stabilizer and tube configuration according to embodiments of the present invention.

[0061] **Figure 6B** is an end perspective view of the stabilizer and tube configuration shown in **Figure 6A**.

[0062] **Figure 7A** is a partial cutaway top perspective view of a surgical tool according to embodiments of the present invention.

[0063] **Figure 7B** is an end perspective view of a shaft with a surgical cautery and tissue-scraping tool head according to embodiments of the present invention.

[0064] **Figure 8A** is a schematic illustration of a circuit according to embodiments of the present invention.

[0065] **Figure 8B** is a schematic illustration of a circuit with a reuse restriction circuit that can self-destruct certain components according to embodiments of the present invention.

[0066] **Figure 8C** is a schematic illustration of a circuit with a combination cautery and motor power source according to embodiments of the present invention.

[0067] **Figure 8D** is a graph of exemplary power curves that an electrosurgical (RF power source) generator can employ according to embodiments of the present invention.

- [0068] **Figure 9A** is an enlarged side perspective view of a sub-assembly of a working tube (guide cannula) with a cooperating hand grip member attached thereto according to embodiments of the present invention.
- [0069] **Figure 9B** is a section view of the sub-assembly shown in **Figure 9A**.
- [0070] **Figure 10A** illustrates the sub-assembly shown in **Figure 9A** used with a dilation tube and k-wire according to embodiments of the present invention.
- [0071] **Figure 10B** is a section view of the cooperating components shown in **Figure 10A**.
- [0072] **Figure 11A** is an enlarged view of an exemplary hand grip member according to embodiments of the present invention.
- [0073] **Figure 11B** is an enlarged view of an opposing side of the hand grip member shown in **Figure 11A**.
- [0074] **Figure 12** is a schematic illustration of a kit for spinal facet surgical procedures to alleviate pain according to embodiments of the present invention.
- [0075] **Figure 13** is an exemplary flow chart of steps that can be used to carry out surgical procedures according to embodiments of the present invention.
- [0076] **Figures 14A-14G** illustrate cooperating components that facilitate a spinal surgery according to embodiments of the present invention.

Detailed Description of Embodiments of the Invention

[0077] The present invention now is described more fully hereinafter with reference to the accompanying drawings, in which embodiments of the invention are shown. This invention may, however, be embodied in many different forms and should not be construed as limited to the embodiments set forth herein; rather, these embodiments are provided so that this disclosure will be thorough and complete, and will fully convey the scope of the invention to those skilled in the art.

[0078] Like numbers refer to like elements throughout. In the figures, the thickness of certain lines, layers, components, elements or features may be exaggerated for clarity. Broken lines illustrate optional features or operations unless specified otherwise. The abbreviations "FIG." and "Fig." are used interchangeably with the word "Figure" in the specification and drawings. One or more features shown and discussed with respect to one embodiment may be included in another embodiment even if not explicitly described or shown with another embodiment.

[0079] The terminology used herein is for the purpose of describing particular embodiments only and is not intended to be limiting of the invention. As used herein, the singular forms "a," "an" and "the" are intended to include the plural forms as well, unless the context clearly indicates otherwise. It will be further understood that the terms "comprises" and/or "comprising," when used in this specification, specify the presence of stated features, integers, steps, operations, elements, and/or components, but do not preclude the presence or addition of one or more other features, integers, steps, operations, elements, components, and/or groups thereof. As used herein, the term "and/or" includes any and all combinations of one or more of the associated listed items. As used herein, phrases such as "between X and Y" and "between about X and Y" should be interpreted to include X and Y. As used herein, phrases such as "between about X and Y" mean "between about X and about Y." As used herein, phrases such as "from about X to Y" mean "from about X to about Y."

[0080] Unless otherwise defined, all terms (including technical and scientific terms) used herein have the same meaning as commonly understood by one of ordinary skill in the art to which this invention belongs. It will be further understood that terms, such as those defined in commonly used dictionaries, should be interpreted as having a meaning that is consistent with their meaning in the context of the specification and relevant art and should not be interpreted in an idealized or overly formal sense unless expressly so defined herein. Well-known functions or constructions may not be described in detail for brevity and/or clarity.

[0081] It will be understood that when an element is referred to as being "on", "attached" to, "connected" to, "coupled" with, "contacting", etc., another element, it can be directly on, attached to, connected to, coupled with or contacting the other element or intervening elements may also be present. In contrast, when an element is referred to as being, for example, "directly on," "directly attached" to, "directly connected" to, "directly coupled" with or "directly contacting" another element, there are no intervening elements present. It will also be appreciated by those of skill in the art that references to a structure or feature that is disposed "adjacent" another feature may have portions that overlap or underlie the adjacent feature.

[0082] Spatially relative terms, such as "under", "below", "lower", "over", "upper" and the like, may be used herein for ease of description to describe one element or feature's relationship to another element(s) or feature(s) as illustrated in the figures. It will be understood that the spatially relative terms are intended to encompass different orientations of the device in use or operation in addition to the orientation depicted in the figures. For

example, if the device in the figures is inverted, elements described as "under" or "beneath" other elements or features would then be oriented "over" the other elements or features. Thus, the exemplary term "under" can encompass both an orientation of over and under. The device may be otherwise oriented (rotated 90 degrees or at other orientations) and the spatially relative descriptors used herein interpreted accordingly. Similarly, the terms "upwardly", "downwardly", "vertical", "horizontal" and the like are used herein for the purpose of explanation only unless specifically indicated otherwise.

[0083] It will be understood that, although the terms first, second, etc. may be used herein to describe various elements, components, regions, layers and/or sections, these elements, components, regions, layers and/or sections should not be limited by these terms. These terms are only used to distinguish one element, component, region, layer or section from another region, layer or section. Thus, a first element, component, region, layer or section discussed below could be termed a second element, component, region, layer or section without departing from the teachings of the present invention. The sequence of operations (or steps) is not limited to the order presented in the claims or figures unless specifically indicated otherwise. In the claims, the word "a" with respect to an element is intended to include one or more of such elements and is not limited to a single such element unless stated otherwise.

[0084] The term "about" means that the recited number or value can vary by +/- 20%.

[0085] The term "sterile" means that the noted device or material meets or exceeds defined medical guidelines of cleanliness as is well known to those of skill in the art to be substantially (if not totally) without contaminants so as to be suitable for medical uses and/or comply with defined medical guidelines, rules and/or regulations.

[0086] Embodiments of the invention are suitable for human or animal use, and are particularly suitable for human use.

[0087] The term "fluted" and derivatives thereof refer to recesses, typically flat or concave grooves, on one or more of the inner wall, outer wall, or shaft of a barrel, drive shaft, rotatable head or column of a surgical tool.

[0088] The term "denudement" and derivatives thereof refer to a procedure to polish, (gently) grind, scrape, file, grate, cleanse and/or rasp away soft tissue of facet joints to thereby denude tissue and uncover or expose the underlying bone without cutting into or removing the bone (e.g., in contrast to a sharp cutting edge like a knife). The denudement tool can have a surface that has an abrasive texture and/or configuration which may include small teeth.

[0089] The term "debridement" and derivatives thereof refer to the removal of soft tissue associated with an end plate receptor region of a target spinal facet joint including the synovial capsule and tissue scraping of an outer boney surface of the joint.

[0090] Generally stated, embodiments of the invention allow spinal facet joint debridement to remove the end plate receptor region which includes the synovial capsule and outer surface of the joint. Once the synovial capsule and outer surface of the joint are denuded, the nerves have nowhere to re-adhere to the joint and thus the joint is permanently denervated (communication between the facet joint and the brain is gone). In studies carried out by one of the inventors, pain relief is permanent in 75-80% of patients.

[0091] While the joint continues to have arthritis, the patient's perception of the pain is gone as pain is what the brain perceives it to be and the patient simply does not feel the spinal pain. The joints have no worse decay then they would with the currently utilized RFL procedure since both utilize a denervation technique where the pain signals are severed between the brain and the joint.

[0092] Advantageously, while the current RFL procedure is a temporary treatment of pain, the spinal facet debridement procedure is a permanent alleviation of pain at the treated spinal facet joint. Thus, the spinal facet debridement procedure is cost effective. For example, currently, people who undergo RFL procedures may have them performed around twice a year for the duration of their lives, while the spinal facet debridement procedure is done once for the affected area. As people age, they may need other areas of the spine treated; for example, a person who has a low back debrided may eventually need the neck debrided. This is similar to the current RFL, in which only a small segment of the spine is done at one time for both patient comfort and time constraints. Usually two or three levels, bilaterally, are performed for either procedure.

[0093] Referring now to the figures, **Figure 1** illustrates a guide cannula **30** (also interchangeably termed a "guide tube" and a "portal") and a stabilizer **40** that snugly holds the guide cannula **30** while allowing a user to adjust a height of the tube below the stabilizer **40**. That is, the stabilizer **40** can include a height adjustment member **44** that cooperates with the guide tube **30** so as to allow a user to adjust where the stabilizer **40** holds the tube **30** thereby adjusting the height of the device **30** inside a patient body and/or below the bottom of the stabilizer **40b**.

[0094] The stabilizer **40** includes a portion with a tubular body **40t** with a lower surface or base **40b** that has a larger cross-sectional or surface area than the tubular body **40t** and can reside against skin **S** of a patient (**Figure 2**). The barrel **10b** of the surgical tool **10**

(**Figure 2**) can extend through a lumen **30l** of the guide cannula **30** while the guide cannula **30** is held in a desired height position by the stabilizer **40**.

[0095] The tool head **15** can have an aperture that merges into a pin receiving channel **11** (**Figure 12**) for guiding placement over a pin or guidewire, for example.

[0096] In the embodiment shown in **Figures 1** and **4A-4D**, the height adjustment member **44** can be biased to have a "normal" position whereby it snugly resides against an outer surface of the tube **40t** and can extend inward inside a window **40w** in the stabilizer tube **40t**. A user can pull, pinch, press, depress or otherwise release or loosen the lateral position of the adjustment member **44** away from the outer surface of the guide cannula **30** thereby allowing the guide cannula **30** to be slid up or down inside the stabilizer tube **40t**.

[0097] **Figures 1, 2** and **4A-4D** also show that the stabilizer **40** can include at least one vacuum port **40v** (shown as a single vacuum port, but more than one may be optionally used). The vacuum port **40v** can be configured as a flexible, rigid or semi-rigid tube segment **40s** that extends (typically radially) outward from the stabilizer tube **40t** that holds the guide cannula **30**. The guide cannula **30** can include at least one fluid port **30p** that is in fluid communication with the vacuum port **40v** during operation of the surgical tool **10**. The vacuum port **40v** can connect to a vacuum source **170** that can suction fluid from inside the guide cannula **30**, out a selected port **30p** and into the vacuum port **40v**.

[0098] With reference to **Figure 2**, the spinal facet therapy delivery tool (e.g., "debrider" tool) **10** has a head **15** that contacts target tissue and the tool barrel **10b** and/or head **15** is rotatable for denudement of the target tissue. The tool **10** can connect to a cautery generator **80**. The cautery generator **80** is also known as an "electrosurgical generator" and "RF power generator." The vacuum port **40v** can connect to a vacuum or suction source **170** via tubing **42**.

[0099] The cautery generator **80** can be any appropriate power, electro-surgery generator including third party generators and/or a custom generator that is dedicated for use in spinal facet surgery, e.g., configured for use only with the tools **10**. If third party generators are used, the tool **10** can include a control circuit **C** that can communicate with a selected generator input so as to be able to operate with multiple different generators. For example, a computer look up table can provide a selection of different defined generators **80** and the control circuit **C** can be used to provide the appropriate settings, automatically or for manual adjustment. The generator **80** may optionally be provided as a custom generator with the tool **10** or made available from an authorized supplier according to defined specifications

of operation to meet regulatory guidelines for medical use and comply with Good Manufacturing Practices, for example.

[00100] As shown in **Figure 8C**, in some embodiments the cautery generator **80** can be provided in a combination unit or housing **80h** that also holds the motor power source **80m** so that the tool **10** can have an electrical connection to the combination unit for powering both functions during a medical procedure. The unit **80h** can thus provide cautery power to the surgical tool **10** and electrical power to the tool **10** for the rotational motor **M** of the device shaft or barrel. Having the generator unit **80h** provide both the cautery and electrical power generation can eliminate the batteries for powering the rotational motor, e.g., batteries are not required to be held onboard the body of the tool.

[00101] During a procedure, typically during or after a defined active cauterizing time, e.g., between about 10-30 seconds of active cauterizing time, with an exemplary cautery site temperature of about 302 degrees F, the vacuum port **40v**, cooperating with the guide cannula **30**, can be configured to vent heat **H** from inside the guide tube **30** (e.g., the lumen **30l**) outside the patient body and maintain a maximum temperature inside the guide cannula **30** to be at about 122 degrees Fahrenheit (degrees F) (e.g., no greater than +2 degrees) or lower, e.g., typically below 122 degrees F and at or above about 80 degrees F. Animal laboratory testing or cadaver testing can be used to test the max temperature using the vacuum port on the stabilizer **40** and cooperating guide tube **30** with the cauterizing surgical tool **10**. By way of comparison, temperatures inside the lumen **30l** of a guide tube **30**, held by a stabilizer **40** (without the vacuum exhaust **40v** that is in fluid communication with the lumen **30l**) during cauterization with a temperature at the cauterization site at about 300 degrees F can reach temperatures above 122 degrees F, more typically about 140 degrees F. The target temperature for humans (away from the cautery site) is under 124 degrees F, such as between 80-124 degrees F, between 80-123 degrees F or between 80-122 degrees F.

[00102] **Figure 3** illustrates a tool **10** with the barrel **10b** which is rotated by an onboard motor **M** powered by either at least one battery (shown as a set of batteries pack **B**, **Figure 7A**) or a DC or AC power source that is remote from the tool **10** such as in a unit housing **80h** with the electrosurgical cautery generator **80c** (**Figure 8C**).

[00103] The tool **10** can include a cord **13** that connects to the cautery generator **80**. The tool **10** can have a pistol grip **10p** with a latch **10d** that allows a user to easily detach or remove the batteries as a pack (where batteries area used) so as to be single-use engineered.

[00104] The tool **10** can also be configured with a circuit **C** (**Figures 8A- 8C**) that automatically destroys components to inhibit reuse.

[00105] Referring to **Figures 4A-4D, 9A and 10A**, for example, the heat exhaust ports **30p** can be longitudinally spaced apart along a length of the guide cannula **30**. Although shown as vertically aligned, they may be laterally offset and may be clustered rather than regularly spaced apart. Also, although shown as a plurality of ports **30p**, the guide cannula **30** may include a single port **30p**.

[00106] Referring to **Figure 4C and 5A**, in some embodiments, the ports **30** may be provided in a closed state prior to user selection of a desired port or ports for a particular procedure or patient. The ports **30p** may include a sealant or cover **33** (**Figure 5A**) that is thermally suitable that attaches to an inner and/or outer wall of the guide cannula **30** and extends over one or more of the ports **30p**. The ports **30p** may be preferentially scored **30s** as shown in **Figure 4C**, but intact so as to be sufficiently sealed to inhibit gas exhaust when intact. The ports **33** can be substantially or totally sealed with thinner wall perimeter segments that can be detached to expose a port **30p** to allow a user to push open a desired port **30p** during or prior to a procedure. **Figure 5B** illustrates that where a cover **33** is used, the cover **33** may be pierced, punctured or pushed open using a shaped end **40e** of a movable arm of the vacuum port **40v**. **Figure 5C** illustrates a separate tool **41** that can be inserted directly into a port **30p** or into the arm of vacuum port **40f** to reach the cover **33** over a desired port **30p** may be included in the surgical tool kit **75** (**Figure 12**).

[00107] **Figure 5D** illustrates that a cover or seal (e.g., a cap) **42** can be attached to the vacuum port **40v**. The cap **42** can also or alternatively be attached to a body **41** with an end **42e** that can push, pierce or otherwise open the port **30p** or the cover **33** over a desired port **30p**. A user can select and open a port **30p** that is at a height that is appropriate for use for a particular procedure (e.g., depending on the height of the guide cannula relative to the stabilizer **40**).

[00108] It is preferred, but not required, that the port **30p** that is used for a procedure align longitudinally and laterally with the vacuum port **40v**. However, the ports **30p, 40v** may be misaligned as long as there is sufficient fluid communication to provide for heated exhaust gases to be removed to keep the temperature in the guide cannula **30** (at least the part that is in the patient body and proximate the skin **S**) at 122 degrees F or below without requiring other active cooling inputs.

[00109] **Figures 6A and 6B** illustrate the height adjustment/lock member **44** can include a finger **44f**, that can flex back and forth in a direction that can be perpendicular to the long axis of the guide cannula **30** to selectively release and lock the guide cannula **30** at a height position as indicated by the arrow. **Figures 6A and 6B** also show that the base **40b**

can have a light weight configuration with a plurality of spaced apart apertures **40a**. Although shown as circumferentially, regularly spaced apart according to some embodiments, the apertures **40a** can be configured with other geometries and may be irregularly spaced apart. The apertures **40a** can be provided as 6 (six) relatively large apertures as shown, lesser apertures (not shown) or a more dense number of smaller apertures (also not shown).

[00110] Figure 7A illustrates the tool **10** can have an onboard control circuit **C** with a user activation input (shown as a push button) **62**. The electric motor **M** turns the shaft **18**, which turns the barrel **10b** and rotates the barrel and cautery element on the head **15**.

[00111] The circuit **C** can include at least one processor **P** that controls operational parameters of the device **10** and/or can monitor for defined inputs such as a defined wattage range of a cautery generator **80**. In preferred embodiments, the maximum wattage of the cautery/electrosurgical generator **80** is between about 40 Watts to about 60 Watts, which is much less than maximum wattages that many surgical cautery generators can provide. Thus, the circuit **C** can be configured to prevent operation, disable operation, turn power off to prevent heating and/or rotation, and optionally send a warning or alert to a user to adjust the wattage if the wattage is above the defined limit, e.g., 40 Watts, 50 Watts or 60 Watts, with a power curve having a maximum output wattage of between 150V-230V, e.g., 150V, 160V, 170V, 180 V, 190V, 200V, 210V, 220 V or 230V and a peak maximum current of 1000 mA.

[00112] As shown in Figure 8D, in some embodiments, the cautery generator **80** can provide the cautery output to the tool **10** using a defined power curve. The graph illustrates three exemplary power curves. The operational power curve can have a maximum voltage of 180 V, 200V or 220V, a maximum current of about 1000 mA and a maximum output wattage of 40W over 0-3000 Ohms. The cautery output can be monopolar, in some embodiments.

[00113] The electrosurgical generator **80** can employ a Field-Programmable Gate Array (FPGA) algorithm for controlling the RF output of the electrosurgical generator **80** for the surgical tool **10**. The generator **80** may use an FPGA algorithm with a power curve with defined maximum values of power, voltage, current. FPGA controls are well known, *see, e.g.*, U.S. Patent No. 6,142,992, the contents of which are hereby incorporated by reference as if recited in full herein.

[00114] In some embodiments, the circuit **C** can be totally onboard the tool body **10b**, totally onboard the cautery generator unit **80** or distributed between the tool body **10b** and the generator unit **80**. The circuit **C** may be distributed in remote devices using an intranet

and/or the internet such as a remote server in a distributed network such as a CLOUD-based network.

[00115] **Figure 8A** illustrates an example of an onboard circuit **C** that can have at least one processor **P** (which can include a digital signal processor), a wattage control circuit **W** in communication with the cautery generator input **80i** which can include a sensor **80s** that can be monitored by the circuit **W**. The processor **P** can control a switch **76** that deactivates the tool **10** and/or turns off or inactivates power to the motor **M**. The processor **P** can send a warning to an onboard or remote display or an audible alert to allow a user to adjust the cautery generator wattage setting if the wattage is above a defined limit, typically above 50 Watts. This control may allow for use with a number of different conventional cautery generators in different clinics or hospitals and/or in different countries.

[00116] In some embodiments, the head **15** can have an electro-conductive member **15e** and/or outer surface to which electrical energy is supplied (in bipolar or monopolar mode), thereby permitting the head **15** to cauterize tissue. The electro-cauterization can be any suitable cautery source, typically RF power, although other electrical sources may be used. For additional discussion of components of a suitable combination spinal facet debrider tool **10**, see, e.g., U.S. Patent No. 8,167,879; and co-pending U.S. Patent Application Serial Number 14/257,490, the contents of which are hereby incorporated by reference as if recited in full herein.

[00117] The distal end portion of the therapy delivery tool **10** with the head **15** can have a maximal outer diameter that is between about 5-15 mm, such as about 5 mm, about 6 mm, about 7 mm, about 8 mm, about 9 mm, about 10 mm, about 11 mm, about 12 mm, about 13 mm, about 14 mm and about 15 mm, typically between 10-12 mm.

[00118] The procedure can be done via conscious sedation and local anesthesia or general anesthesia as per the surgeon's and patient's preference. For, example, conscious sedation can be used with a remifentanyl mixture. The spinal region is typically prepped and draped accordingly. Utilizing fluoroscopic or other suitable imaging guidance, the facet joints **J** that may be treated can be identified.

[00119] To facilitate a minimally invasive treatment, a semi-rigid or rigid guidewire and/or pin **20** (e.g., a Steinman pin)(**Figure 12**) with a diameter of approximately 1 mm can be inserted through skin **S** and tissue of a patient into the target facet joint region. The guidewire/pin **20** can be tapped into place with a small hammer or other suitable device. A small incision, typically between about 0.25-1 inch, e.g., about ½ inch or about ¾ of an inch

can be made about the pin **20**. In other embodiments, the incision can be made before or during the insertion of the pin **20**.

[00120] The guide cannula **30** (sometimes also called "a working cannula" or "portal" as discussed above) can be inserted into the patient so that a distal end thereof **30d** (**Figure 1**) resides proximate the target facet site **J** (**Figure 2**). The guide cannula **30** can be inserted over the guide pin **20** to help position the guide cannula **30** in the body. Typically, as shown in **Figures 10A** and **10B**, the guide cannula **30** is inserted over a dilation tube **50** which is first inserted over the guide pin or wire **20**.

[00121] The (external) stabilizer **40** holds the guide cannula **30** in position. The guidewire/pin **20** and dilation tube **50** may be removed before or after placement of the stabilizer **40**.

[00122] In some embodiments, as shown in **Figures 9A, 9B, 10A, 10B, 11A** and **11B**, a hand grip member **200** (sometimes also called "portal driver") can be attached to the guide cannula **30** to cause the distal end of the guide cannula **30d** to cut through adjacent tissue thereunder to be able to have the distal end of the guide cannula **30d** remain at the joint **J** (**Figure 2**) even when the pressing force from the hand grip member **200** is removed. That is, when just inserting a guide cannula **30** to the location **J** over the dilation tube **50**, the underlying tissue may have sufficient resiliency to resist the placement of the distal end of the guide cannula **30d** so as to "reset" or relocate the location of the distal end of the guide cannula to be about 2-20 mm from a bone surface of the target **J** when the guide cannula **30** is merely pushed into a target position over the dilation tube **50** and/or pin **20**. To assure proper and close placement of the distal end of the guide cannula **30**, a user can manually rotate and press inward against the hand grip member **200** to thereby cause the distal end of the guide cannula **30** to cut through the tissue proximate the joint **J**.

[00123] Typically, once the distal end of the guide cannula **30** is proximate a target site (e.g., within 0.001 mm to about 5 mm of the bone at the joint **J**), a user grips the member **200** while concurrently pushing and rotating the member **200** to carry out the desired placement of the distal end of the guide cannula **30d**. There is no need to twist the hand grip **200** while pressing against it for an entire insertion length. Also, the amount of pushing force applied by a hand of a user while twisting the member **200** is relatively low and easily manually applied, typically the pressing force is in a range of about 5 to about 50 Newtons. It is also contemplated that the twist can be in a single direction and less than one revolution to place the device **30d**.

[00124] Referring to **Figures 9A, 9B, 10A, 10B, 11A and 11B**, the hand grip member **200** can allow a user to apply an inward force **F** concurrently with a rotation **R** as indicated by the arrows in **Figure 9A**. In some embodiments, the hand grip member **200** can be releasably affixed to an outer end portion of the guide cannula **30**. In some embodiments, the member **200** can be detached from the guide cannula **30** and may be removed before placing the stabilizer **40**. In some embodiments, the hand grip member **200** can remain in position and cooperate with the stabilizer **40** during a surgical procedure. In some embodiments, the hand grip member **200** may be an integral part of the guide cannula **30**.

[00125] As shown in **Figures 9A, 9B, 11A and 11B**, for example, the hand grip member **200** can have a tubular portion **202** with a cylindrical channel **204** that snugly slidably receives an upper end portion of the guide cannula **30**. The channel **204** can be a through-channel as shown in **Figures 10B and 11A**, for example.

[00126] The hand grip member **200** can have a hand-grip **205** that resides above the tubular portion **202** and that has a larger radial extent than the tubular portion **202**. The hand grip **205** can be substantially circular, typically with a diameter that is greater than that of the guide cannula **30**, such as between 2X and 5X greater than the diameter of the guide cannula **30**. The hand grip **205** may include an outer perimeter with spaced apart protrusions **207** that can provide finger grip features and/or anti-slide surfaces. The cylindrical channel **204** can have an interior circumferentially extending stop **200s** that resides between opposing upper and lower portions of the channel **204**, typically below but adjacent the hand grip **205**. The proximal end the guide cannula **130p** can abut against the stop **200s** as shown in **Figures 9B and 10B**.

[00127] As also shown in **Figures 9A and 9B**, the tubular portion **202** of the hand grip member **200** can have an inner wall with at least one longitudinally extending recess **208** that matably receives a corresponding longitudinally extending protrusion **133** on the outer wall of the guide cannula **30**, which may optionally hold the exhaust ports **30p**. The opposite configuration may also be used, e.g., the inner wall of the tubular portion **202** can have the protrusion while the guide cannula outer wall can have the recess or combinations of these or other configurations that allow the fixation for rotation of the guide cannula **30** with the hand grip member **200**.

[00128] As shown in **Figures 10A and 10B**, the hand grip **200** can be attached to the guide cannula **30** and receive a k-wire or pin **20** as well as the dilation tube **50** in the channel **204**. The proximal end **130p** of the guide cannula **30** can reside under the hand grip **205** with the proximal end **150p** of the dilation tube **50** above as shown. In other embodiments, the

guide cannula **30** can extend through the hand grip **205** and reside above the hand grip **205** along with the dilation tube and guide-wire or pin **20** (**Figures 10A, 14A-14F**). Typically, at least the k-wire or pin **20** remains in the guide cannula **30** as a user rotates and pushes against the hand grip member **200** to cut through tissue to position the guide cannula distal end **30d** at the target site **J** so that it remains there upon removal of the force applied to the hand grip member **200** and/or removal of the hand grip member **200** from the guide cannula **30** (for detachable versions). The stabilizer **40** can be positioned on the guide cannula **30** after it is in proper position or before or during. In some particular embodiments, the hand grip member **200** can be detached from the guide cannula **30**, then the stabilizer **40** placed on the patient and attached to the guide cannula **30**.

[00129] **Figures 10A and 10B** also illustrate that the k-wire or pin **20** can include visible markings **120** for a visual reference that a user can see to align with a top or proximal end of the guide cannula **130p** and/or dilation tube **50**. As the k-wire or pin **20** touches bone at the target treatment site **J**, assessment of position of the distal end of the guide cannula **30d** and/or dilation tube **50** can be made relative to the visible markings **120**. The visible markings **120** can be striations, notches, embossments, color markings, graduated measurement indicia marks or combinations of same. The upper end portion of the dilation tube **50** may be visually transmissive, such as translucent or transparent. The upper end of the dilation tube may also include visual reference indicia markings (not shown).

[00130] The stabilizer **40** can be configured to provide a depth stop for the therapy delivery tool **10** and optionally structural, such as rotational stabilization for the tool barrel **10b** proximate the skin entry site **S**. The stabilizer device **40** can slidably receive and releasably hold the guide cannula **30** and tool barrel **10b** and may be used without requiring the guide pin **20**, e.g., the guide pin **20** may not be used or may be withdrawn prior to or after the stabilizer **40** is in position on the patient while holding the guide cannula **30** at a desired stop depth.

[00131] As shown in **Figures 1, 2, 4A-4D**, the stabilizer **40** can have a bottom **40b** that resides against skin **S** of the patient, either directly or indirectly. The bottom **40b** can have a width **W** of between about 2-6 inches, typically between about 3-5 inches, such as about 3 inches, about 3.5 inches, about 4 inches, about 4.5 inches and about 5 inches. The bottom **40b** can have a larger width than the width of the stabilizer tube **40t** which has a through-channel **40c** for the guide cannula **30** and/or tool **10**. The stabilizer tube **40t** typically has a smaller height than the height of the barrel **10b** (**Figure 12**) of the therapy delivery tool **10** and/or height of the guide cannula **30**. In some particular embodiments, the stabilizer **40** can

have a height that is between about 2-10 inches, typically between about 3-6 inches, such as about 3 inches, about 3.5 inches, about 4 inches, about 4.5 inches, about 5 inches, about 5.5 inches, and about 6 inches, although the stabilizer may have other height dimensions.

[00132] As shown in **Figures 1, 2 and 4A-4D**, the stabilizer **40** can releasably, slidably engage the guide cannula **30**. The stabilizer **40** can be configured with the height adjustment member **44** configured to releasably lock against the outer surface of the guide cannula **30**. The locking engagement **44** can be provided using a physical lock member (e.g., a clamp or other suitable lock) or a locking configuration, e.g., frictional engagement or other locking configuration. The stabilizer **40** and cannula **30** engagement can be through any suitable physical engagement that allows the stabilizer **40** to lock against the cannula **30** directly or indirectly and preferably also allows for the height adjustment of the cannula **30** in the stabilizer **40**.

[00133] The therapy device **10** can be configured such that when the elongate barrel **10b** is inserted fully through the guide cannula **30** in an operative configuration, the head **15** and/or distal end of the therapy device **10d** extends beyond the front or distal end **30d** of the cannula **30**

only by between about 2 mm to about 7 mm, such as about 2 mm, about 2.5 mm, about 3 mm, about 3.5 mm, about 4 mm, about 4.5 mm, about 5 mm, about 5.5 mm, about 6 mm, about 6.5 mm or about 7 mm. Thus, the stabilizer **40** locks the cannula **30** in a longitudinal position and the stabilized/locked position of the cannula **30** relative to the skin of the patient **S** based on the stabilizer **40** keeps the distal end **10d** of the barrel **10b** and/or head **15** at the target site and acts as a stop to keep the head **15** from moving deeper into the body.

[00134] As shown in **Figure 2**, the top of the guide cannula **30t** and a tool interface **10i** can cooperate to keep the tool barrel **10b** can define a hard stop and keep the tool barrel **10b** from moving further inward relative to the cannula **30**. The cannula and tool interface **10i** can be provided in any suitable configuration. In the example illustrated, the interface **10i** is shown based on the shape of the tool and top of the cannula **30t**, e.g., through abutting contact to provide a physical interference/stop.

[00135] The stabilizer **40** may optionally provide some structural support for the guide cannula **30** and/or tool **10** at the entry site. As noted above, the stabilizer **40** can have a bottom **40b** that has a greater width/surface area than the primary body **40b**. The width of the bottom **40b** can be larger than the width of the cannula **30** by between two-ten times. Typically, the stabilizer bottom **40b** has a width that is between about 1-6 inches, more typically between about 3 to about 5 inches. The stabilizer bottom **40b** can be thin, typically

between about 1-10 mm, more typically between about 2 to about 4 mm. The bottom **40b** can be semi-rigid or rigid. The bottom **40b** can be configured to conformably reside against the skin of the patient.

[00136] As shown in **Figure 4C**, the guide cannula **30** can have visual depth markings **30i**, typically in an incremented, graduated scale. The scale can be in microns or millimeters or other defined increments of length position. In some embodiments, the depth indicia marking **30i** may be color-coded to reflect shorter versus longer depths or having depth indicia for visual correlation of depths for different treatment levels of the spine.

[00137] The longitudinal position of the guide cannula **30** relative to the stabilizer **40** can be adjustable to allow a clinician to adjust for a specific patient and/or target joint to thereby adjust the intrabody depth of the therapy tool delivery head **15** once inserted into the guide cannula **30** that is locked into its desired position by the stabilizer **40**.

[00138] In some embodiments, a dilation tube **50** (**Figures 10A, 10B, 12**) can be fed over the guide pin **20**, typically after the guide pin distal end is anchored to the treatment site of the facet joint **J**. The dilation tube **50** can be configured with a plurality of cooperating components including an inner tube with a distal end having a tapered end (e.g., a bullet-like shape). The tapered (bullet shaped) end can be inserted down to the facet joint **J**. The tapered end **50b** can be sized and configured to push through the muscle to create an opening, preferably without cutting the muscle.

[00139] Optionally, the cannula **30** can slidably extend and reside over the dilation tube **50**. The cannula **30** may be sized and configured to snugly reside against the tube **50** so that it does not freely slide along the tube **50** without pushing by a user. The cannula **30** can be positioned upstream of the tapered end on the dilation tube **50** prior to inserting the dilation tube in the body. In other embodiments, the cannula **30** can be separately inserted over the dilation tube **50** after the dilation tube **50** is inserted into the body. In any event, once the tapered end reaches the facet joint **J**, the guide cannula **30** (e.g., working tube) can be pushed down to the facet joint **J** so that the distal end **30d** of the cannula **30** resides at the facet joint. The dilation tube **50** can then be removed, leaving the cannula **30** in position.

[00140] The stabilizer **40** can have an open channel **40c** that allows the dilation tube **50** and/or the guide cannula **30** to extend therethrough.

[00141] The guide cannula **30** is typically rigid. The guide cannula **30** can be formed or include materials that may be compatible with autoclaving for sterilization. The guide cannula **30** can be metallic or other non-toxic and/or biocompatible material that is sufficiently rigid and that may be high-temperature (autoclave) heat-resistant or suitable for

the thermal exposure during cauterization. Other sterilization protocols may be used that do not require heat. The guide cannula **30** can be metallic (and if so can have an electrically insulating material over an end portion or surface thereof) or may be polymeric or other plastic material with sufficient rigidity to provide the guide path for the tool **10**. One exemplary material, by way of example only, is Polyether ether ketone (PEEK).

[00142] In some particular embodiments, the guide cannula **30** may comprise a stainless steel material with an inner surface having an electrically insulating material. The electrical insulating material can be configured to inhibit arcing with the electro-cautery output, e.g., RF energy at the head **15**, when the tool is configured to apply RF energy for the cauterization. The electrical insulating material can be provided by an internal sleeve or coating or otherwise. The insulating material may reside on only a distal end portion of the guide cannula **30** or over an entire inner surface of the cannula **30**. The electrically insulating material may optionally reside on the outer surface of the guide cannula **30**, such as on the distal end thereof.

[00143] It is also noted that the guide pin/wire **20** is optional and that the dilation tube **50** may be inserted without requiring the use of the guide wire/pin **20**. Also, where used, the guidewire/pin **20** may extend through the cannula **30** rather than the barrel of the tool **10b** and is not required to extend along a centerline of the device **10b, 30**. For example, the cannula **30** can have a guidewire channel residing about a perimeter segment.

[00144] The stabilizer **40** can be positioned prior to, during or after insertion of the guidewire/pin **20** (where used), the dilation tube **50** and/or the cannula **30**.

[00145] The tool head **15** can be rotated to denude tissue until bone at the target spinal facet joint is reached. In preferred embodiments, the rotation of the head **15** can be automatic using a motor **M** (**Figure 7A, 8C**) with a drive shaft **18** (**Figure 7A, 7B**) connected to the therapy tool head **15**. However, in some embodiments, the denudement head **15** can be manually rotated. The therapy tool head **15** is also configured to cauterize the soft tissue during and/or after the denuding.

[00146] As shown in **Figures 2, 7A and 7B**, in some embodiments, the tool **10** can have an elongate barrel **10b** and/or shaft **18** with a length sufficient to reach the target intrabody spinal facet site. The length of the barrel **10b** and/or shaft **18** can be between about 100 mm to about 150 mm.

[00147] The cannula **30** can have a diameter that is slightly larger than the outer diameter of the shaft **18** and/or tool barrel **10b**, e.g., between about 0.1 mm to about 1 mm to allow snug sliding entry of the tool **10**. The tool **10** can have various form factors. The

barrel **10b** may rotate or be static. The barrel **10b** can form part of the drive shaft **18** and rotate with the head **15** as an integral or separate component thereof or substantially or totally encase the drive shaft **18** of the rotating head **15**.

[00148] During use, the proper "stop" for a treatment and/or denuding action can be confirmed by a manual tactile feel since the debrider tool **10** can be made to remove the soft capsular tissue and superficial lining of the joint **J** but when the bone is reached by the head **15**, the tool **10** will not advance or there will be increased resistance and the surgeon can "feel" in a tactile feedback manner that he or she is up against the hard surface of the bone. However, as noted herein, sensors can be used to provide feedback/electronic control.

[00149] The denuding of target soft tissue with the tool **10** can have a short duration (with the active rotation of the debridement tool head) that is between about 10 seconds to about 2 minutes long, typically between about 20 seconds to about 40 seconds, on average.

[00150] The tool **10** can be configured to continuously rotate the head **15** during both cauterization and subsequent (light) tissue scraping/cleansing upon contact with bone at the facet joint **J**. In some embodiments, the tool **10** can be configured to discontinuously rotate the head **15** and/or interleave the cauterization with the rotation.

[00151] Once the soft tissue is denuded, the tool head **15** can be rotated with sufficient force and time to contact the outer surface of the bone under the denuded tissue for a desired short time, e.g., between about 10 seconds to about 2 minutes, more typically between about 10 seconds to about 60 seconds, to cleanse an exposed outer surface of the bone thereat substantially without removing bone. The short tissue cleansing/scraping time, post-cauterization (e.g., post-denuding), can be controlled with an auto-shutoff for the tool rotation and can be timed based on user or electronic (auto) shut off of the cautery/burn or based on sensor feedback of contact with bone.

[00152] The tool **10** can be rotated with the same rotational speed for the bone surface cleansing relative to the denuding action or with a different rotational speed and/or force for the bone surface cleansing relative to the denuding action. In some embodiments, the tool **10** has a first defined rotational speed range for the denuding and a different defined rotational speed range for the cleansing. The transition from denuding (with or without cauterizing) to cleansing can be automatic or manual. If automatic, a sensor can trigger the transition to a different speed and/or to terminate the power to stop the cauterizing action. If manual, a user interface (UI) via a control such as a switch or a voice prompt to a control circuit can direct the change in operation, e.g., slow rotation and stop cautery/burn.

[00153] In some embodiments, the tool **10** can be configured to apply the cauterization without rotation of the head **15** then cleanse/tissue scrape with the rotation of the head **15**. This may be particularly suitable for laser, ultrasound or cryo-ablation configurations.

[00154] As shown in **Figure 7A**, by way of example only, in some particular embodiments, the different speeds can be selectively applied by the user via at least one user input **61**, such as denude and cleanse mode control inputs on the tool **10** that are in communication with the control circuit **C** and motor **M**. The inputs **61** may be a single physical input comprising one or more UI **61**, such as knobs, buttons, triggers, or GUI inputs on a miniature touch screen display onboard or in communication with the tool **10**. The UI can comprise voice-based inputs/commands, e.g., "START DENUDE, START/STOP CAUTERIZE, START/STOP SCRAPE" and the like.

[00155] The different speeds for the cleanse and denude modes (where both modes are used) may be automatically applied by the control circuit **50** based on input from the sensor, where used. In some embodiments, the cleanse mode has a 10-100% faster rotation speed than the denude mode while in other embodiments, the cleanse mode has a slower rotation speed (e.g., 10-100% slower) than the denude mode.

[00156] The speed of the therapy delivery tool head **15** (e.g., a tissue scraper and cautery head) can be relatively low to avoid cutting into the bone. Most orthopedic burrs will operate up to 60,000 rpm which can be hard to control and can dig into the bone. Thus, lower rotational speeds are desired for the denuding and/or cleanse modes or action. The objective is to sweep the tissue off the bone and not drill into the bone during the cleanse mode. Thus, in some embodiments, for either and/or both denuding and cleansing of the bone, a speed of below about 5000 rpm may be appropriate, typically between about 10 rpm to about 5000 rpm, and more typically between about 10-1000 rpm. If the tool shaft or barrel is rotated during cauterizing, the speed may be different for the cauterizing, the denuding and the tissue cleansing/scraping. In some embodiments, the speed for each is between about 10 to about 5000, including about 125 rpm, about 150 rpm, about 200 rpm, about 250 rpm, about 300 rpm, about 350 rpm, about 400 rpm, about 450 rpm, about 500 rpm, about 550 rpm, about 600 rpm, about 650 rpm, about 700 rpm, about 750 rpm, about 800 rpm, about 850 rpm, about 900 rpm, about 950 rpm, about 1000 rpm, about 1500 rpm, about 2000 rpm, about 2500 rpm, about 3000 rpm, about 3500 rpm, about 4000 rpm, about 4500 rpm and about 5000 rpm.

[00157] In some embodiments, the speed is low speed for one or both the denuding (with or without cauterizing) and the cleansing. The term "low speed" means between about

10 rpm to about 100 rpm, including about 10 rpm, about 15 rpm, about 20 rpm, about 30 rpm, about 40 rpm, about 45 rpm, about 50 rpm, about 60 rpm, about 70 rpm, about 80 rpm, about 90 rpm and about 100 rpm.

[00158] While not necessary, the tool **10** can have a cleanse run mode that rotates the therapy delivery tool head **15** at a slower speed than a denuding speed. In some embodiments, the tool **10** can have a substantially constant rpm with a controlled maximum output of maximum operational capacity at full speed of between about 10 rpm to about 5000 rpm, typically between about 10 and 200 rpm, and more typically with a maximum rotational speed of between about 10 rpm to about 100 rpm.

[00159] As discussed above with respect to **Figure 8A**, the tool **10** can include a circuit **C** that has a speed limiter control **77** to insure that the maximal rotational speed allowed is between about 10-5000 rpm. The use of properly sized gears/clutches, speed governors, electronic cut off sensors or other mechanisms can be used to control the maximal speed.

[00160] The tool **10** can be configured to have a maximum speed (at full speed) that is between about 10 to about 5000 rpm, typically between about 10-1000 rpm such as between about 10-500 rpm or between about 10-100 rpm including about 40 rpm, about 45 rpm, about 50 rpm, about 55 rpm, about 60 rpm, about 65 rpm, about 70 rpm, about 75 rpm, about 80 rpm, about 85 rpm, about 90 rpm, about 95 rpm and about 100 rpm.

[00161] In some embodiments, a viewing scope can be placed in the cannula **30** or in an adjacent cannula or port (not shown) to allow real time viewing of the spinal joint **J** during the therapy.

[00162] The denuded soft capsular tissue can be suctioned via vacuum or otherwise removed by the spinal facet therapy (e.g., debrider) tool **10** and/or via the guide cannula **30** and vacuum port **40v** of the stabilizer **40** or with another tool. In some embodiments, the tool barrel **10b** can be in fluid communication with an irrigation source and/or a vacuum/suction source. The tool barrel **10b** can comprise an irrigation channel and a suction/vacuum channel with respective ports on the distal end of the tool **10d** (see, Figure 25C and 26 of the co-pending application incorporated by reference hereinabove). A single channel can be used for both irrigation and suction where both functions are provided. In some embodiments, no tissue removal is required.

[00163] The surgical site **J** can be flushed out with saline or other suitable cleansing liquid and suctioned and removed. The flushing of the site can be carried out using the tool **10** or without the tool **10**. If the latter, the tool barrel **10b** can reside in the cannula **30** during

the irrigation and/or suction. The cannula **30** may remain in place during the flushing or removed before this action. The stabilizer **40**, where used, can be removed before or after the guide cannula **30**. The therapy delivery tool **10** can be removed before, after or with removing the cannula **30**. The guide pin **20** can be removed before, after or with the tool **10** and/or cannula **30** (or even earlier if not needed according to some embodiments, for example).

[00164] This procedure can be repeated for each joint selected for treatment.

Typically, between two and six joints **J** can be treated at one therapy session.

[00165] In some embodiments, to save time, all of the guide pins **20** on one side for each joint **J** can be placed before any incisions and/or before debriding at any level. Sterile surgical tape such as 3M™ Steri-Strips™ and/or a small suture (or surgical glue) can be placed to close a respective incision wound once the therapy is complete.

[00166] Post-pin placement, the entire spinal facet treatment procedure for one joint **J** can take between five to fifteen minutes. The procedure can be an outpatient procedure and the patient can typically walk the same day with recovery over a week to let the surgical sites heal.

[00167] **Figure 12** illustrates an example of a spinal facet debridement surgical tool kit **75**. As shown, the kit **75** can include a package **75p** with sterile components that facilitate the surgery. The kit **75** can include a debrider tool **10** (which can be the entire therapy delivery tool **10** or a consumable, single use disposable or multi-use barrel **10b**), optionally a plurality of guide pins **20₁**, **20₂** (shown as two, but one or more than two can be provided, or the pins can be provided separately outside the kit), a dilation tube **50** and at least one guide cannula **30** (or working tube), and the stabilizer **40**. The kit **75** may also include the hand grip member **200**. While shown as kits with all the noted components for facilitating ease of surgical preparation, the components may be provided as separate units or sub-sets.

[00168] The guide cannula **30** can be provided pre-attached to the dilation tube **50** or hand grip **200**, or may be provided as a separate unassembled component. For bilateral and/or multi-level procedures, more than one guide cannula **30** and, where used, more than one stabilizer **40**, may be included, and if so, may be labeled for right and left sides and/or for indicating spinal treatment levels. The guide pins **20** can be provided in a common size or different sizes, typically with a diameter that is between about 0.75-1.25 mm, more typically about 1.0 mm.

[00169] **Figure 13** is a flow chart of exemplary actions that can be used to carry out a spinal facet treatment to alleviate pain associated with arthritis. A guidewire/pin is typically

inserted into a target spinal facet joint over a synovial capsule of a spinal facet joint (block 105). A dilation tube with a distal end having a tapered bullet shape is inserted over the guide pin to dilate an entry path to the target spinal facet joint through muscle (block 110). A cannula is slidably advanced over the dilation tube to rest against the target spinal facet joint (block 115).

[00170] A hand grip can be attached to the guide cannula (block 116) before, during or after the advancing step. A user can concurrently rotate and push the hand grip to thereby rotate and push the distal end of the guide cannula to cut through local tissue and position the distal end of the guide cannula at the target intrabody site (block 117). The dilation tube with the bullet shape can be removed, as can the hand grip and optionally the k-wire/pin (in no particular order), leaving the guide cannula with an open channel extending therethrough in position (block 120). An external stabilizer can be placed against the skin of the patient prior to, during or after the guide cannula is advanced (block 118). In some particular embodiments, the stabilizer is placed on the patient after the hand grip and/or dilation tube are removed.

[00171] An elongate debridement tool with a denudement head having cauterization capability ("combination tool") is provided (block 125). The combination tool is inserted into the cannula such that the head resides against a surface of a target spinal facet joint (block 130). Soft capsular tissue and a superficial lining of the target spinal facet joint are denuded by rotating the head (block 135). Tissue at the target joint is cauterized using the head (block 140). Fluid is suctioned from the guide cannula through a vacuum port in the stabilizer out of the patient during the cauterizing (block 141) to thereby reduce heat in the guide cannula.

[00172] The treated joint can be flushed and suctioned. The therapy delivery (e.g., debrider) tool, cannula and guide pin can be removed and the incision entrance closed (block 145).

[00173] In some embodiments, the denuding and/or cauterizing can be carried out using a low rotation speed for the rotatable tool head (block 137).

[00174] In some embodiments, a plurality of guide pins can be inserted, one for each different target spinal facet joints (block 106). Steps 110, 115, 120, 130, 135, 140 and 145 can be repeated at each respective different spinal facet joint, typically between 2-6 joints, including 2 joints, 3 joints, 4 joints, 5 joints and 6 joints (block 107). Usually two or three levels, bilaterally, are debrided during a single surgical session.

[00175] The denudement typically lasts between about 10 seconds to 3 minutes (average), more typically between about 20 seconds to 40 seconds (average), and the entire

procedure (post pin placement or including pin placement) for one joint can be carried out in about 5-15 minutes (typically bilaterally per joint) (block 147).

[00176] The head 10 can be configured to denude and cauterize soft tissue at the target spinal facet joint either serially (e.g., intermittently or interleaved) and/or concurrently. The tool 10 can allow a user to select when to cauterize or it can be configured to automatically cauterize during the entire denuding action, during a portion of the denuding action, or after a denuding action.

[00177] In some embodiments, the method can include electronically sensing when denuding is complete upon contact with bone under the capsular joint (block 137). The method may optionally include electronically generating an audible or visual alert to a user when the head contacts the bone and/or when the denuding of soft tissue is complete (block 138).

[00178] In some embodiments, the target spinal facet joint is a lumbar facet joint and the cannula 30 and debridement tool 10 can be inserted in a lumbar region at between a 10 to about a 40 degree angle, typically between about 20-30 degrees for this region (block 133). Other levels, e.g., cervical and thoracic debridement may be at other angles typically between about 0 to about 10 degrees.

[00179] It will be appreciated that angulation of the tool 10 can change depending on scoliosis, etc. Typically, the lumbar region is between about 10 to about 40 degrees as noted above. However, the angulation is appropriate so as to be perpendicular to the target spinal facet joint surface, which is usually about 10 to about 40 degrees laterally in the lumbar region and between about 0 to about 10 degrees laterally in the thoracic and cervical regions.

[00180] In some embodiments, the order of use of the components where the stabilizer 40 is used can be: insert the guide pin 20, then insert the dilator tube 50. Next, the stabilizer 40 can be placed on the skin S over the guide pin 20 and/or dilator tube 50. The dilator tube 50 can then be removed if it was used. The guide cannula 30 and/or therapy tool 10 can be inserted through the stabilizer 40 with or without the guide pin 20 in place (that is the guide pin 20 can have been previously removed or removed after the cannula 30 and/or tool 10 are inserted through the stabilizer 40). The tool 10 can deliver the therapy to the facet joint J with the pin in position and extending through the pin bore 11 or the therapy to the facet joint can be applied after the pin 20 is withdrawn.

[00181] In some embodiments, the order of use of the surgical tools can be as shown, in serial order with respect to the next set of noted figures: insert guide pin or k-wire 20 (Figure 14A), insert dilator 50 over the pin/wire 20 (Figure 14B), insert guide cannula 30

over dilator **50** (Figure 14E), then attach the hand grip **200** (Figure 14F). As discussed above, the hand grip **200** can be (typically manually) rotated and pushed concurrently to cut through adjacent tissue and place the distal end of the guide cannula **30d** at the target spinal facet treatment site **J**. Where a detachable hand grip **200** is used, the hand grip **200** can be removed from the guide cannula **30** before the stabilizer **40** is attached. Figures 14C, 14E and 14G illustrate that the dilator **50** may also include visual indicia **150** to allow a user to align/ascertain a depth thereof relative to the guide pin visual indicia **120**, for example. The guide pin/k-wire **20** can have a sharp distal end **20d** (Figures 14B, 14D). Figures 14B and 14F illustrate that the dilator **50** may be visually transmissive.

[00182] The stop depth provided by the stabilizer **40** and/or stabilizer and guide cannula **30** combination may be adjustable. The clinician can decide an appropriate stop depth for the patient prior to placing one or more of the components in the patient.

[00183] The stabilizer **40** can also be placed on the skin **S** before or after the guide pin **20** is inserted at the treatment joint **J**. The stabilizer **40** may have a bottom surface **40b** that can releasably attach to skin of the patient via adhesive or vacuum and the like and define an entry portal for the procedure.

[00184] The entire tool **10** with the cable **13** can be sterile and single use disposable.

[00185] The tool **10** can be configured to inhibit re-use. For example, the tool **10** can have a reuse restriction circuit **180** as shown in Figures 8A-8C. The reuse restriction circuit **180** can be in communication with the processor **P** or configured as part of the processor **P** itself or partly held on the processor **P**, the circuit **C** and/or partly in a separate circuit of the tool **10**. The reuse restriction circuit **180** can include or be in communication with one or more of a time-out circuit **180t**, an on and/or off counter **180c** (to control a defined number of power-up, power down operations and/or a number of successive power up and power downs, for example), and/or a self-destruct circuit **180d**, to automatically disable the device **10** from being able to operate to thereby restrict further use. The self-destruct circuit **180d** can be configured to destroy certain components and/or functionality of the tool **10**. The time-out circuit **180t** can be configured to shut down or not power up after a power off and/or after a defined time from a defined trigger event. The on/off counter **180c** can be configured to limit the number of on/off uses to less than 10, typically between 3-6, to allow for multiple level treatments and allow a user to power-off between levels.

[00186] The "trigger" event, can be based on one or a combination of a power-on or power off-event of the tool **10**, electronic detection of a cautery output at the end of the barrel of the tool, which may be determined using a temperature or other sensor on the end of the

tool **10**. The trigger event can be an active denuding time or an active cleansing time, post cauterization, associated with motor rotation. The trigger event can be based on a logic control of the processor **P** based on a plurality of pre-defined trigger event conditions to start the time period such as (a) the tool being in a power-on state, (b) the presence of a cautery temperature at the tool barrel, and (c) rotation of the motor. The defined time may be sufficient to allow for multiple spinal facet levels to be treated for a respective patient using one tool **10**, thus the time, when electronically sensed can be a cumulative time based on active motor time, time from power on, a defined number of power on/power off events, and the like. The defined time can be less than about 1 hour, typically between about 5 minutes to about 30 minutes, such as about 6 minutes, about 7 minutes, about 8 minutes, about 9 minutes, about 10 minutes, about 11 minutes, about 12 minutes, about 13 minutes, about 14 minutes, about 15 minutes, about 16 minutes, about 17 minutes, about 18 minutes, about 19 minutes, about 20 minutes, about 25 minutes and about 30 minutes, for example.

[00187] As shown in **Figure 8B**, by way of example only, the tool circuit **C** can include a reuse restriction circuit **180** that includes a self destruct circuit **180d** that can carry out a self destruct mode based on one or more defined parameters. In some embodiments, the one or more defined parameters includes a pre-defined time period, which may be automatically timed using a clock or timer in communication with the reuse restriction circuit **180**, typically in the processor **P** of the circuit **10**. The clock or timer can be configured to time a period of allowable operation based on a power on a "trigger" event as described above and may be any of the time periods described above and/or trigger based on defined trigger event conditions as discussed above.

[00188] As shown in **Figure 8B**, the tool can generate an audio and/or visual output **180a** to alert a user that the tool **10** has been self-destructed to destroy functionality of the tool **10**. The output **180** may be a flashing (e.g., red) LED or other alert indicator. As shown by the circles with the X, the self-destruct mode can be configured to disable or destroy operational capability of the processor **P** and/or disconnect or destroy an electrical connection **10c** from one or more internal component such as the battery **B** or the cautery input **80i**. The self-destruct mode can use the battery **B** or the cautery generator **80** via input **80i** to electrically destroy one or more internal components or electrically or mechanically disconnect power such as by cutting a wire or cord in a power cable or connector associated with same, for example after a time out period and/or an attempt to power-on after the first authorized use, e.g., after 30 minutes from an initial power up.

[00189] In some embodiments, the self destruction circuit **180d** can be configured so that if the surgical tool **10** is disconnected (after a first operation or "on" potentially for a defined time) from a physical connection, e.g., plug in, to the generator **80** or generator unit **80h** (**Figure 8C**), the device **10** will self-destruct. In some embodiments, circuitry **C** in communication with (typically onboard) the device **10** can be configured to sense that a power connection has been terminated and automatically destroy functionality of one or more components. The tool **10** cannot function to operably connect to a generator **80** or generator housing **80h** for a second power on, (e.g., a second surgical case).

[00190] **Figures 7A and 7B** also illustrate that the shaft **18** extends to the rotating head **15** and can be configured with a fluted configuration **15f** to inhibit tissue clogging during denuding or tissue scraping. The fluted configuration can have curvilinear longitudinally extending recesses **15r**.

[00191] The flutes **15f** can be straight or curvilinear. The flutes **15f** can be thin, e.g., between about 1 mm to about 5 mm. The flutes **15f** can extend longitudinally over a small portion of the length of the shaft and/or barrel **10b**, such as between about 3 mm to 1 inch, or over substantially a length of the shaft and/or barrel **10b** sufficient to extend through the working cannula **30**, e.g., a length between about 50 mm to about 200 mm, including about 50 mm, about 75 mm, about 100 mm, about 150 mm and about 200 mm. The head lateral dimension can be between about 3-15 mm (if a non-expandable configuration is used) and between about 3-25 mm if an expandable version is used. In some embodiments, a maximal distal head lateral dimension with the flutes **15f** can be between about 5-15 mm such as about 5 mm, about 6 mm, about 7 mm, about 8 mm, about 9 mm, about 10 mm, about 11 mm, about 12 mm, about 13 mm, about 14 mm, and about 15 mm.

[00192] As shown in **Figures 7A and 7B**, the head **15** can include a single medially-located linear conductive electro-cautery segment **15e**. The linear cautery element **15e** can be continuous and extend across the entire face of the head **15**. As shown in **Figure 7B**, the linear cautery element **15e** bisects the face of the tool head **15** and can separate two opposing, non-conductive scraping members **15s**. The scraping members **15s** can comprise PEAK or PEEK material, for example. The scraping members **15s** may extend a distance of between about 0.5 mm to about 5 mm beyond the cautery element **15e**. The scraping members **15s** can be used for both denuding, before cauterization and tissue cleansing (post cauterization), but typically a concurrent cautery and scraping action is carried out, by rotating the head at a low rpm during cautery, typically between 10 and 100 rpm, as discussed above.

[00193] The head **15** can be a monolithic unitary member with the electrocautery surface(s) **15e** and flutes **15f**. The entire shaft with the head can be a monolithic conductive member. The head **15** and/or shaft with the head can be a suitable medical grade electrically conductive material such as stainless steel. The head **15** may comprise a discrete electrocautery member **15e** that is of a different material than the fluted shaft **15f**. That is, as shown, the discrete electrocautery member **15e** can reside in or extend from a non-conductive (electrically insulating) shaft **18** and/or barrel **10b**. The discrete electrocautery member **15e** can be configured to slidably, longitudinally extend and retract relative to the adjacent non-conductive shaft or barrel or may be statically affixed to same.

[00194] It is contemplated that the spinal facet debridement procedure with the combination debrider tool **10** can allow the spinal debridement procedure to be carried out by general surgeons, radiologist, pain medicine, physical medicine, orthopedic and neurosurgeons and/or allow more surgeons to be able to competently carry out the procedure thereby providing more global access to this treatment for patients with longer term pain relief and obviating the need for follow-up treatments upon nerve reinnervation at the treated spinal facet joint(s).

[00195] Embodiments of the invention provide treatment methods that can be carried out at an outpatient clinic and/or as an outpatient procedure at a hospital or surgery center.

[00196] While the foregoing written description of the invention enables one of ordinary skill to make and use what is considered presently to be the best mode thereof, those of ordinary skill will understand and appreciate the existence of variations, combinations, and equivalents of the specific embodiment, method, and examples herein. The invention should therefore not be limited by the above described embodiment, method, and examples, but by all embodiments and methods within the scope and spirit of the invention as claimed.

THAT WHICH IS CLAIMED:

1. A method of minimally invasively treating a patient for back pain, comprising:
 - introducing a guide cannula into the patient so that a distal end resides proximate a target spinal facet joint;
 - attaching the guide cannula to an external stabilizer before, during or after the introducing step; then
 - denuding and cauterizing soft tissue at the target spinal facet joint, serially or concurrently, using a tool with a denuding and cauterization head that extends through the guide cannula, wherein the denuding is carried out by rotating the head of the tool to remove an end plate receptor region comprising a synovial capsule of the spinal facet joint thereby treating back pain; and
 - suctioning fluid from the guide cannula and out of a vacuum port in the stabilizer during the cauterizing to exhaust heat generated from the cauterizing.
2. The method of Claim 1, wherein the guide cannula has a plurality of longitudinally spaced apart heat exhaust ports, the method further comprising aligning a selected guide cannula heat exhaust port with the stabilizer vacuum port before or during the attaching step.
3. The method of Claim 1, wherein the attaching is carried out to lockingly engage an external portion of the guide cannula at a desired user adjustable height to position a distal end of the guide cannula at the target spinal facet joint before the denuding and cauterizing is carried out.
4. The method of Claim 1, wherein the introducing step is carried out by concurrently manually rotating and pushing the guide cannula inward toward the target spinal facet joint over a dilation tube to position the distal end of the guide cannula proximate the target spinal facet joint before the denuding and cauterizing.

5. The method of Claim 1, further comprising concurrently rotating and pushing the guide cannula inward toward the target spinal facet joint before attaching the guide cannula to the external stabilizer.

6. The method of Claim 4, wherein the concurrent rotating and pushing are carried out using a hand grip attached to an external portion of the guide cannula.

7. The method of Claim 1, wherein the introducing step is carried out by first inserting a k-wire or pin into the patient into bone at the target spinal facet joint, then inserting a dilation tube over the k-wire or pin into the patient, then inserting the guide cannula over the dilation tube, wherein a hand grip is attached to the guide cannula before, during or after the guide cannula is inserted over the dilation tube so that the dilation tube and k-wire or pin extend out of the hand grip above the guide cannula, then concurrently rotating and pushing inward against the hand grip to cut through tissue adjacent the target spinal facet joint and thereby position a distal end of the guide cannula at the target spinal facet joint.

8. The method of Claim 7, wherein the introducing step further comprises visually confirming the guide cannula is in a desired location by referring to visual guide marks on the k-wire or pin above the hand grip.

9. The method of Claim 1, wherein the method further comprises before the cauterizing and denuding, connecting the tool to an electro-surgical generator with an RF source, and wherein the cauterizing is carried out using a power curve with a maximum output wattage of 50 Watts, a maximum current of 1000 mA, and a maximum voltage in a range of 180V and 220 V.

10. The method of Claim 9, wherein the power curve for the electro-surgical generator has a maximum output wattage of 40 Watts, a maximum current of 1000 mA, and a maximum voltage in a range of 180 V and 220 V (optionally with an ohmic range of 0-3000 ohms).

11. A method of minimally invasively treating a patient for back pain, comprising:

denuding a target spinal facet joint using a combination cautery and denuding tool, wherein the denuding is carried out by rotating a head of the tool at a rotational speed of between 10 and 5000 rotations per minute to remove an end plate receptor region comprising a synovial capsule of the spinal facet joint thereby treating back pain;

cauterizing the target spinal facet joint, serially or concurrently with the denuding, using the combination cautery and denuding tool connected to an electrosurgical generator having a power curve with a maximum output wattage of 40 Watts, a maximum current of 1000 mA, and a maximum voltage in a range of 180V and 220 V; and

suctioning heat during at least the cauterizing to exhaust heat generated from the cauterizing.

12. Surgical tools for spinal facet surgical procedures for alleviating spinal pain, comprising:

a guide cannula with a wall surrounding a longitudinally extending open channel, the wall having a plurality of longitudinally spaced apart fluid ports extending therethrough; and

an external stabilizer with a base configured to rest against skin of a patient, wherein the base holds a tube that extends longitudinally outward above the base and comprises at least one vacuum port, wherein the tube releasably engages the guide cannula, and wherein, when assembled, the stabilizer at least one vacuum port is in fluid communication with at least one of the guide cannula fluid ports.

13. The surgical tools of Claim 12, wherein the tube that extends longitudinally outward above the base holds an arm that substantially orthogonally outward from an axial direction of the tube proximate the at least one vacuum port, and wherein the arm releasably engages a conduit of a vacuum source.

14. The surgical tools of Claim 12 or 13, wherein the guide cannula fluid ports are closed until selectively opened by a user.

15. The surgical tools of any of Claims 12-14, further comprising a hand grip member configured to attach to the guide cannula to thereby allow a user to concurrently rotate and push against the guide cannula.

16. The surgical tools of any of Claims 12-15, wherein the hand grip member has an open center channel extending therethrough with a circumferentially extending stop surface that releasably engages a proximal end of the guide cannula.

17. The surgical tools of any of Claim 15, wherein the hand grip member comprises a longitudinally extending recess that slidably engages a longitudinally extending protrusion on the guide cannula, and wherein the longitudinally extending guide cannula protrusion holds the longitudinally spaced apart fluid ports.

18. The surgical tools of any of Claims 12-17, further comprising a k-wire or guide pin or a k-wire and guide pin that has visual markings thereon for allowing a user to determine a depth of a distal end of the guide cannula relative to the k-wire or guide pin or k-wire and guide pin when the k-wire or guide pin is or the k-wire and guide pin are in bone at a target spinal facet joint.

19. A surgical tool comprising:

an external stabilizer configured with a base having a bottom surface that is adapted to reside against skin of a patient, wherein the base has or holds an upwardly extending tube with an upwardly extending through channel, wherein the tube has a wall that includes a vacuum port extending therethrough, wherein the tube holds an arm that extends away from an axial direction of the tube about the vacuum port, and wherein the arm is adapted to attach to a conduit to engage a vacuum source.

20. The surgical tool of Claim 19, in combination with a guide cannula, wherein the guide cannula has a wall that surrounds an open longitudinally extending through-channel, the guide cannula wall comprising a plurality of longitudinally spaced apart fluid ports extending through the guide cannula wall, wherein the tube is sized and configured to releasably hold the guide cannula while allowing the guide cannula to slidably align at least one of the guide cannula ports with the tube vacuum port.

21. The surgical tool of Claim 20, in further combination with a hand grip that detachably engages the guide cannula, wherein the hand grip has an open center channel that is concentric with the guide cannula channel, and wherein the bottom surface of the stabilizer has a perimeter with a maximal width that is between about 2-6 inches.

22. A surgical tool for spinal facet therapy comprising:

a housing;

an electric motor in the housing;

a shaft held by the housing that rotates to turn a cautery and denudement head at a low speed, wherein the shaft has a head with a linear cautery element and first and second diametrically opposing tissue scraping members that face each other across the linear cautery element;

a connector that electrically connects the cautery and denudement head to a power source; and

a circuit in the housing configured to carry out one or both of: (i) monitor wattage supplied by the cautery source to inhibit or prevent operation if wattage is above 50 Watts; and/or (ii) destroy or disengage one or more components of the tool based on at least one defined triggering event to inhibit re-use.

23. The surgical tool of Claim 22, further comprising:

a guide cannula having longitudinally spaced apart fluid ports extending through a wall thereof, wherein the shaft of the surgical tool is sized and configured to slidably extend down through the guide cannula; and

an external stabilizer with a base and an upwardly extending tube above the base, wherein the tube has an arm that releasably engages conduit that extends to a vacuum source, and wherein the base is adapted to reside against skin of a patient while the tube engages an outer wall of the guide cannula.

24. A spinal facet therapy system, comprising:

an electrosurgical generator having a defined operational power curve with a maximum wattage of 60 Watts;

a spinal facet therapy tool with an elongate rotatable shaft, the shaft having a distal end with a cautery element, the tool in communication with the electrosurgical generator, wherein the tool is configured to automatically rotate at between about 10 rpm to about 5000 rpm and is adapted to remove an end plate receptor region comprising a synovial capsule of the spinal facet joint, and wherein the electrosurgical generator supplies power to the cautery element while the shaft rotates or is stationary;

a guide cannula with at least one fluid port extending through a longitudinally extending wall thereof, the guide cannula configured to hold the tool shaft during an active treatment; and

an external stabilizer residing against skin of a patient and holding the guide cannula therein during the active treatment, wherein the external stabilizer comprises at least one vacuum port in fluid communication with the guide cannula at least one fluid port and a vacuum source to thereby suction heat from the guide cannula when the cautery element is cauterizing.

25. The spinal therapy system of Claim 24, wherein the tool has an onboard electrical motor, wherein the electrosurgical generator comprises a Field-Programmable Gate Array (FPGA) architecture for controlling output based on the defined power curve, and wherein the electrosurgical generator is held in a housing that also holds a power source for the motor.

26. The spinal therapy system of Claim 24 or 25, wherein the power curve has a maximum output wattage of 50 Watts, a maximum current of 1000 mA, and a maximum voltage in a range of 180 V-220 V.

27. The spinal therapy system of an of Claims 24 or 25, wherein the power curve has a maximum output wattage of 40 Watts, a maximum current of 1000 mA, and a maximum voltage of 180V- 220 V (optionally with an ohmic range of or within 0-3000 ohms).

28. The spinal therapy system of any of Claims 24-27, further comprising a hand grip member configured to detachably couple to the guide cannula to thereby allow a user to concurrently rotate and push against the guide cannula to place the

guide cannula in a desired position prior to inserting the tool shaft into the guide cannula.

29. The spinal therapy system of Claim 28, wherein the hand grip member has an open center channel extending therethrough with a circumferentially extending stop surface that releasably engages a proximal end of the guide cannula.

30. The spinal therapy system of Claim 28, wherein the hand grip member comprises a longitudinally extending recess that slidably engages a longitudinally extending protrusion on the guide cannula, and wherein the longitudinally extending guide cannula protrusion holds the longitudinally spaced apart fluid ports.

31. The spinal therapy system of any of Claims 24-30, further comprising a k-wire or guide pin that has visual markings thereon for allowing a user to determine a depth of a distal end of the guide cannula relative to the k-wire or guide pin when the k-wire or guide pin is in bone at a target spinal facet joint.

32. The spinal therapy system of any of Claims 24-31, wherein the cautery element is a linear cautery element that extends straight across a distal face of the distal end of the shaft, and wherein the distal end of the shaft also includes first and second diametrically opposing tissue scraping members that face each other across the linear cautery element.

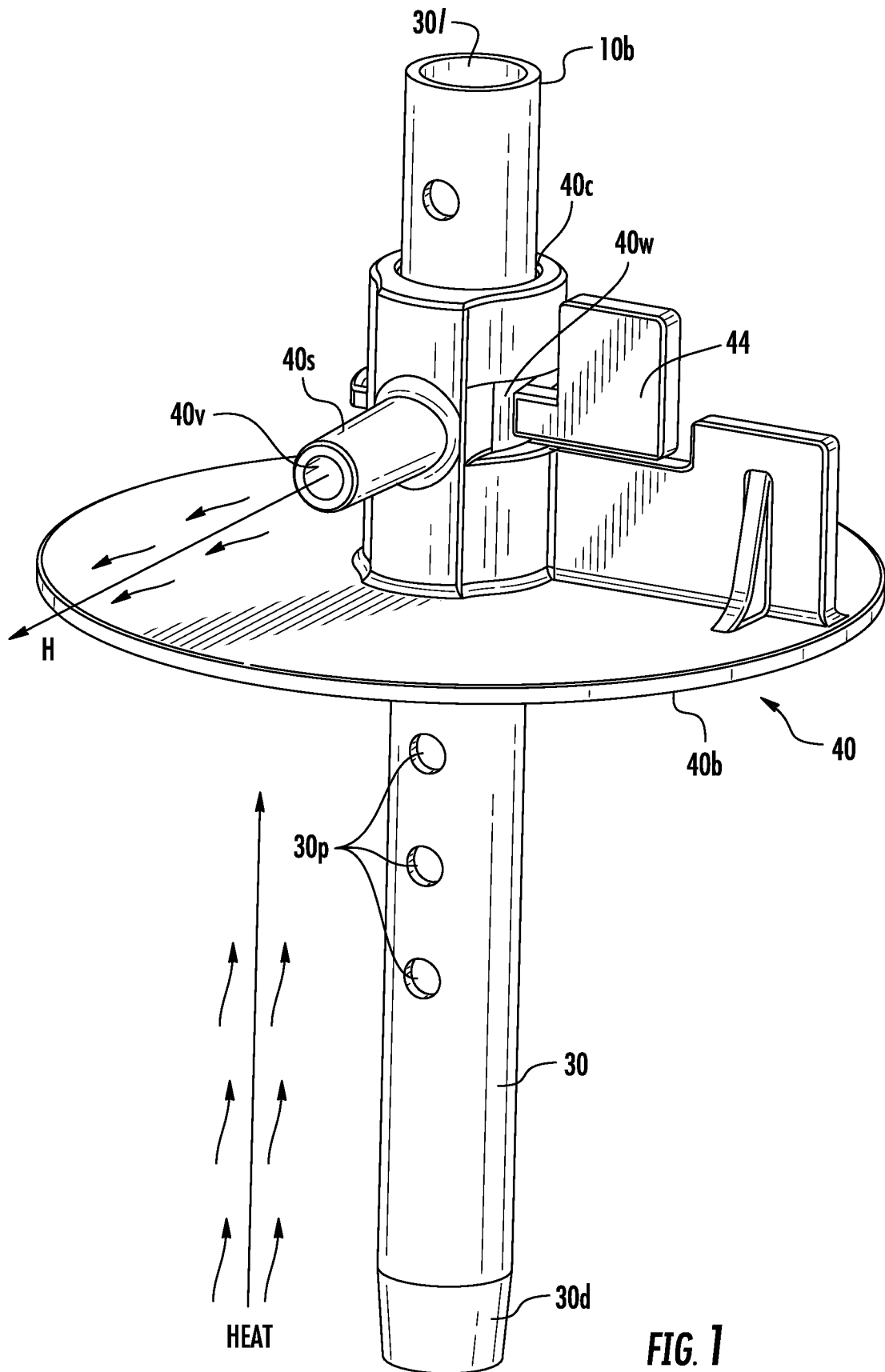
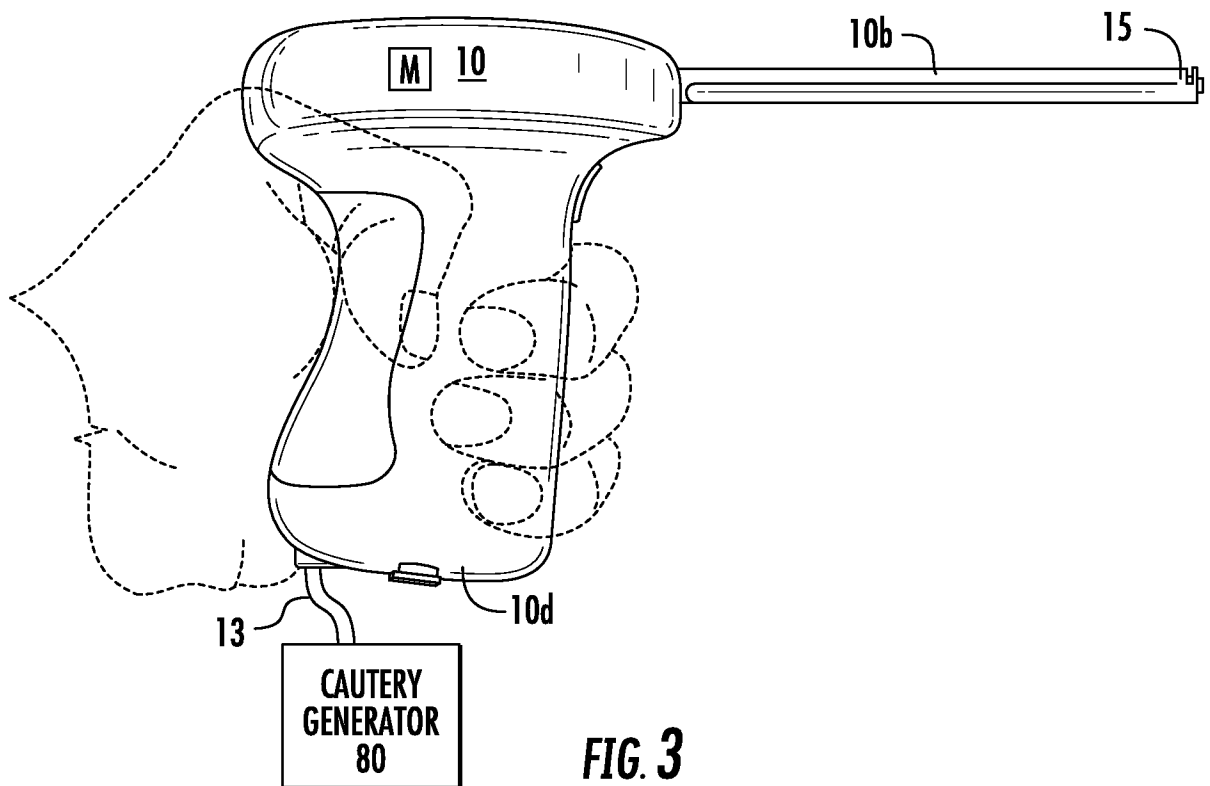
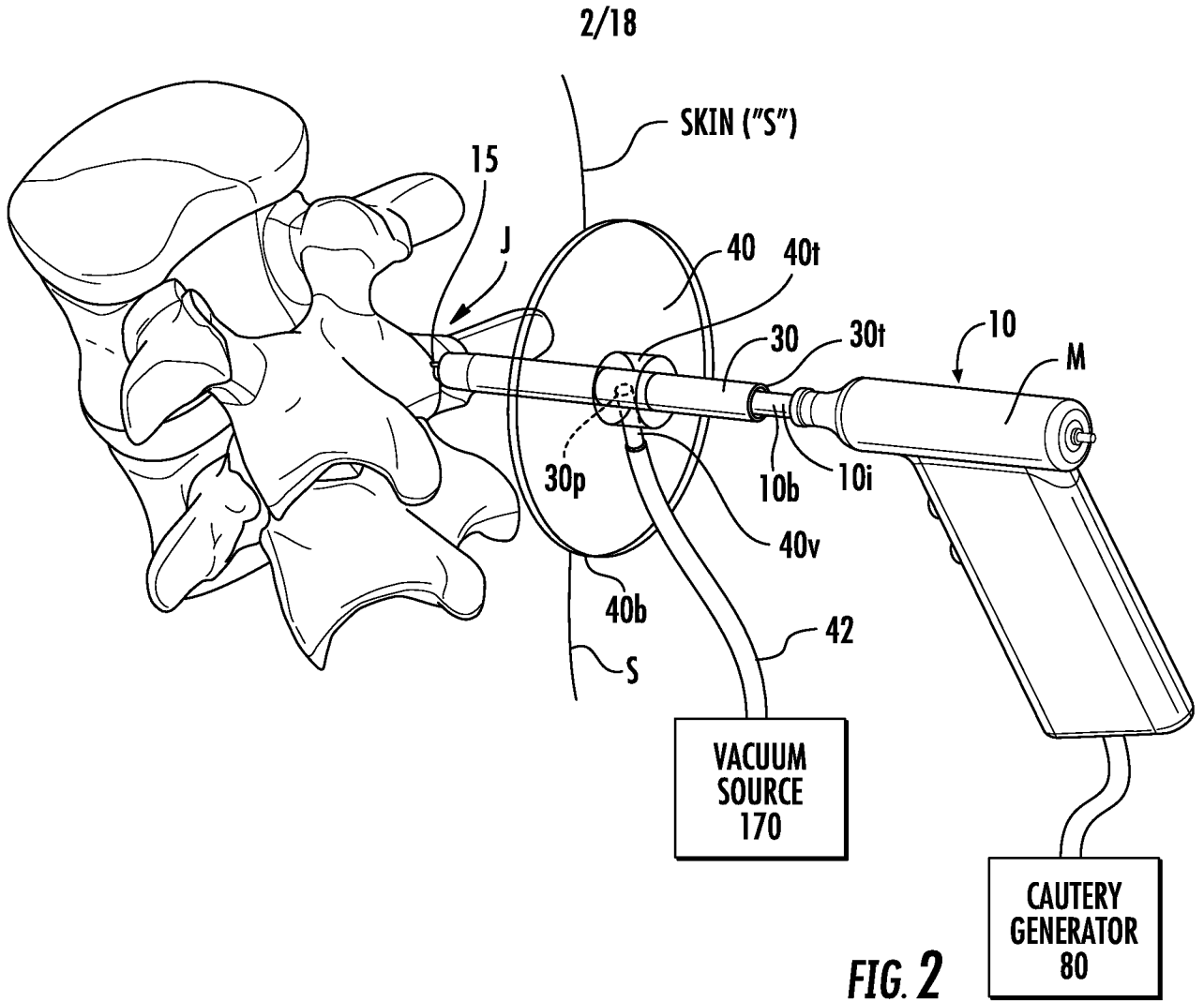

FIG. 1



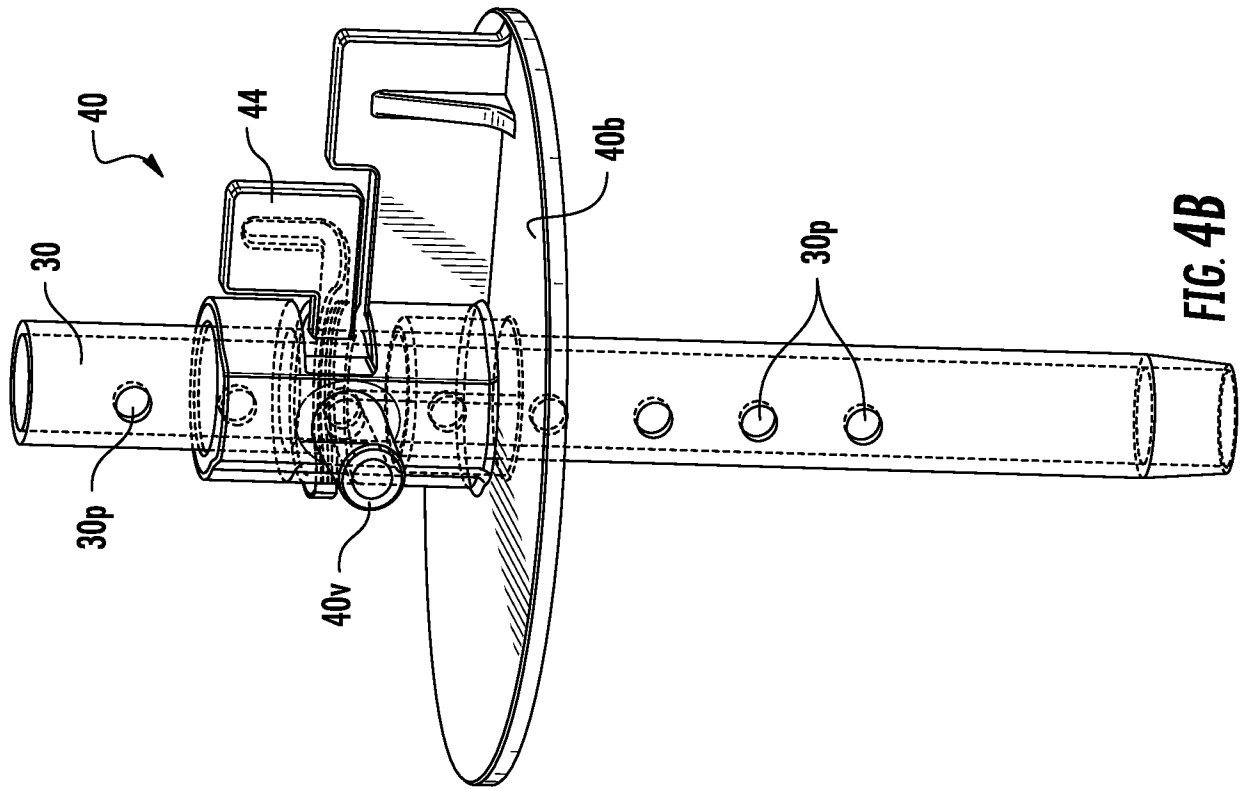

FIG. 4B

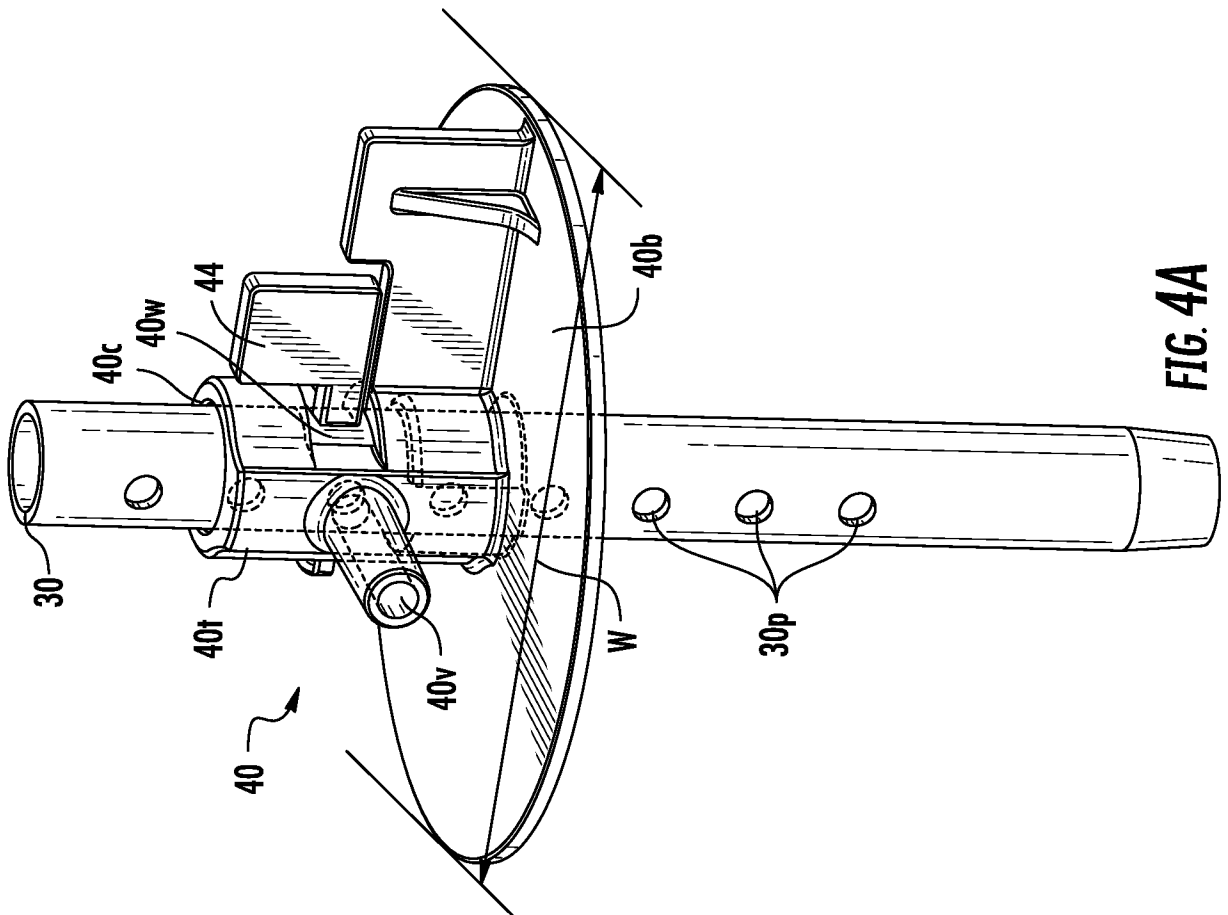

FIG. 4A

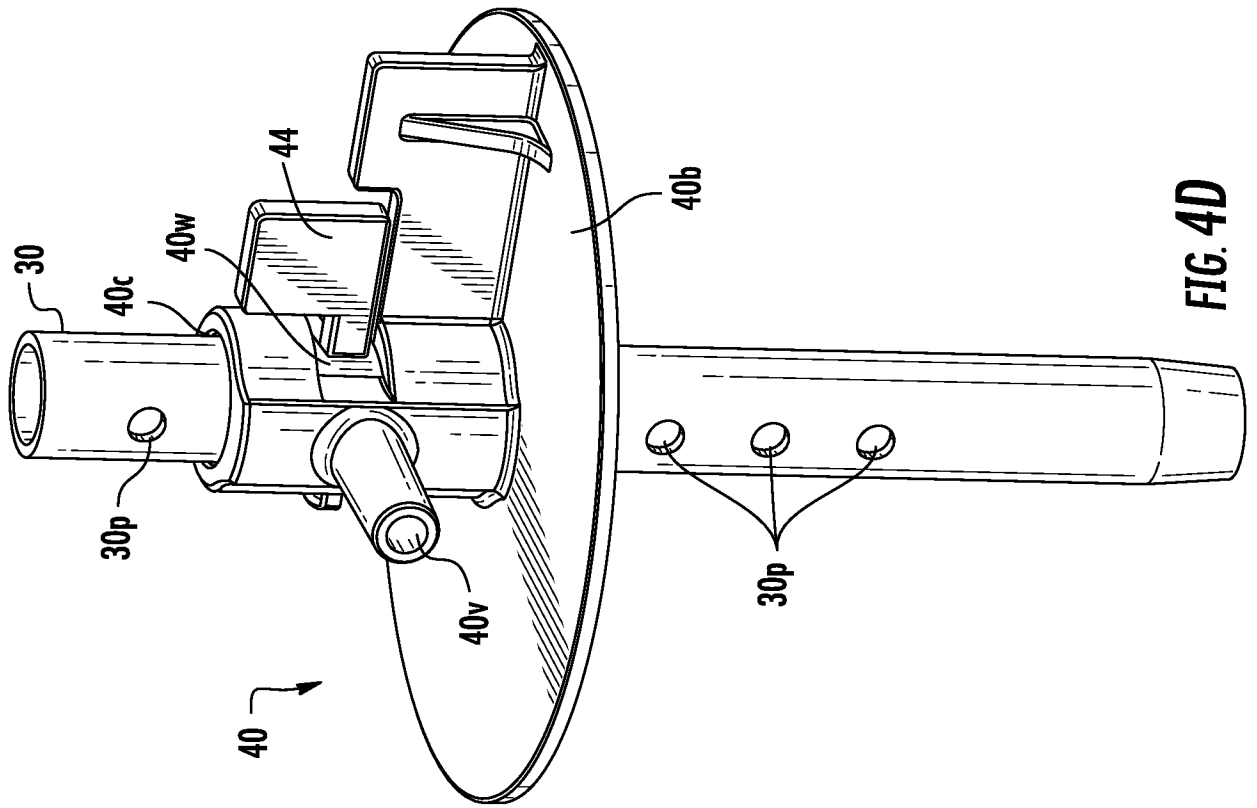

FIG. 4D

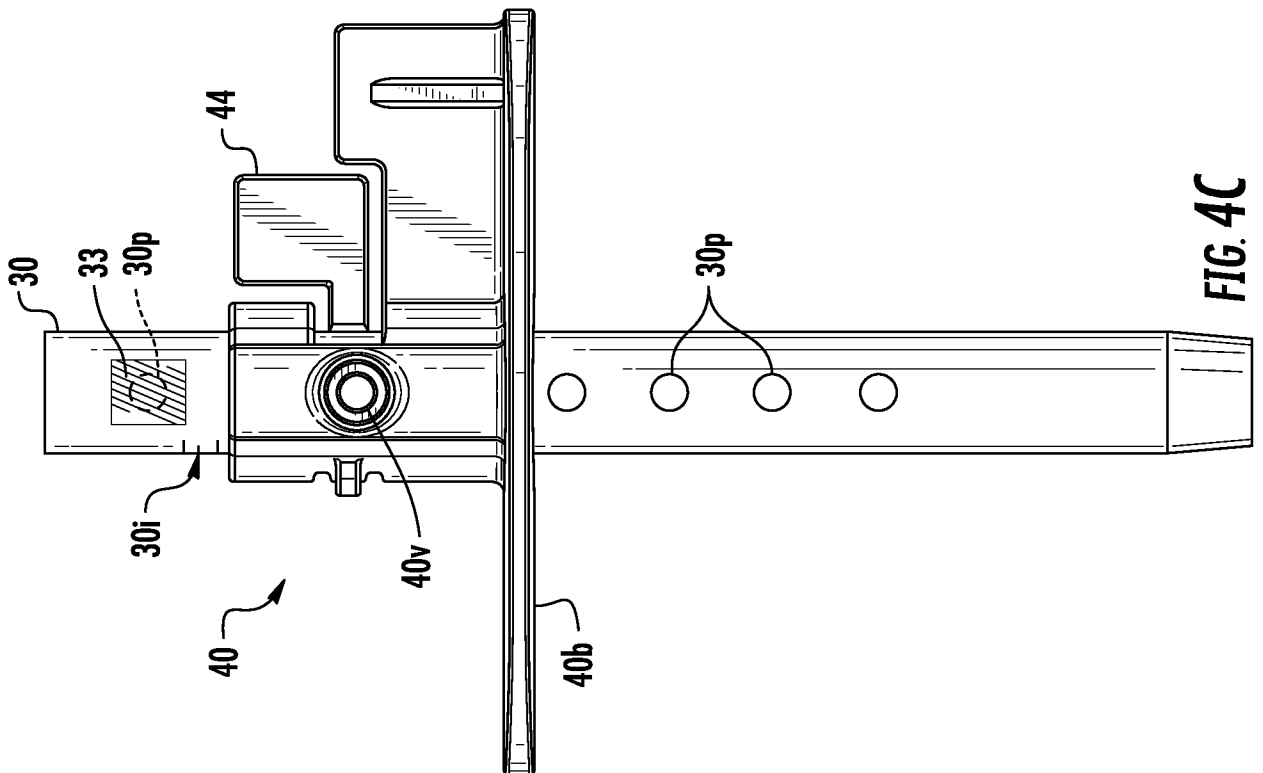

FIG. 4C

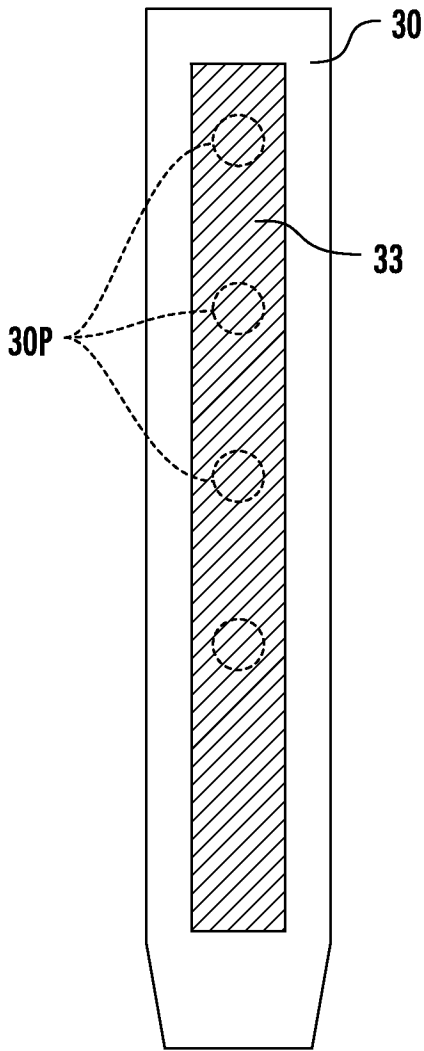

FIG. 5A

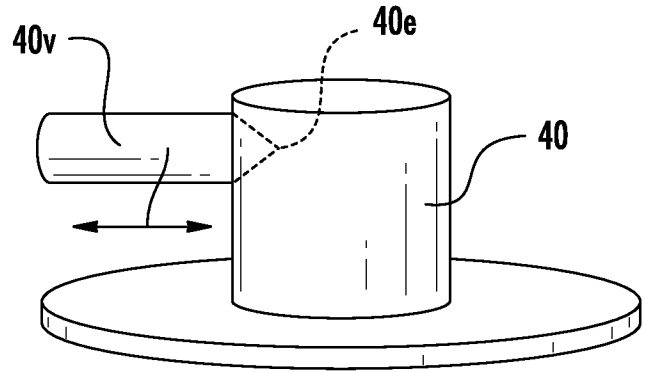

FIG. 5B

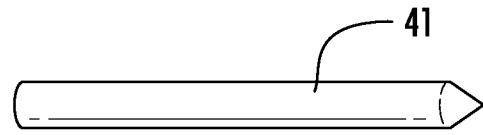

FIG. 5C

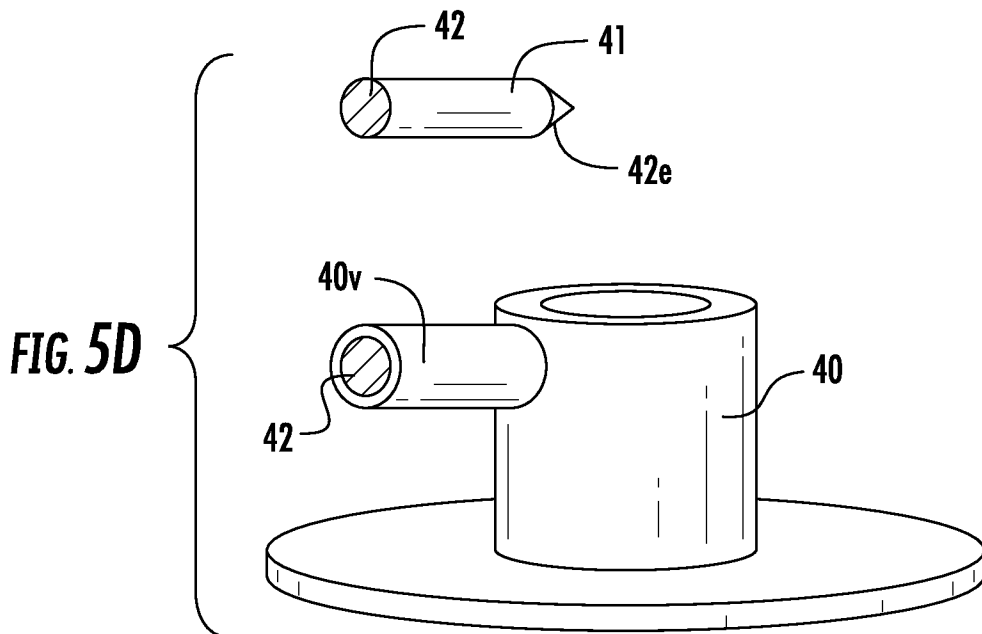
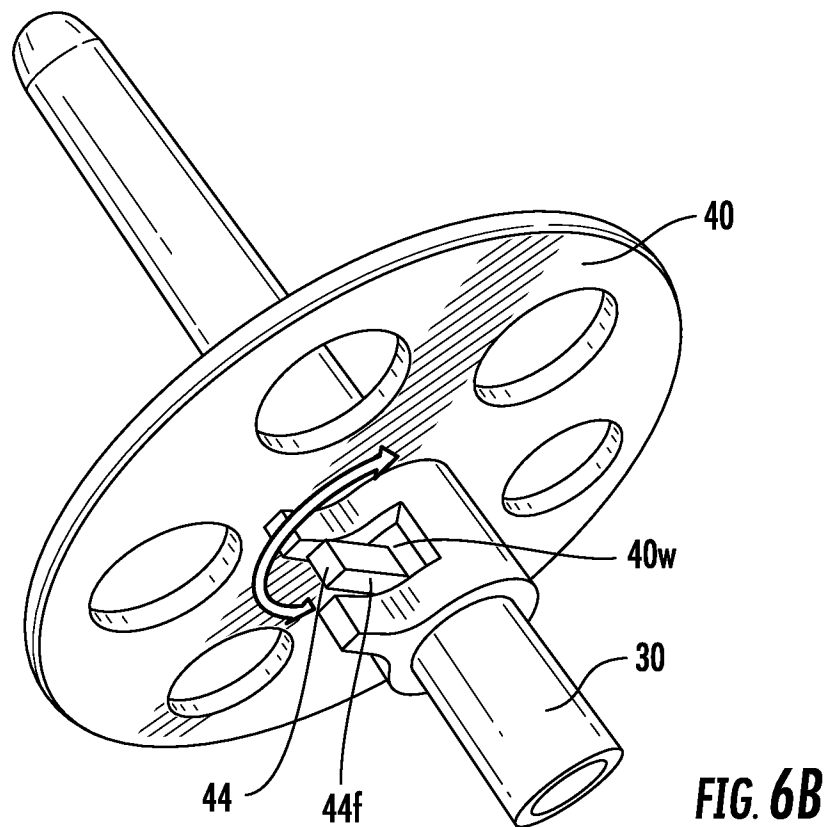
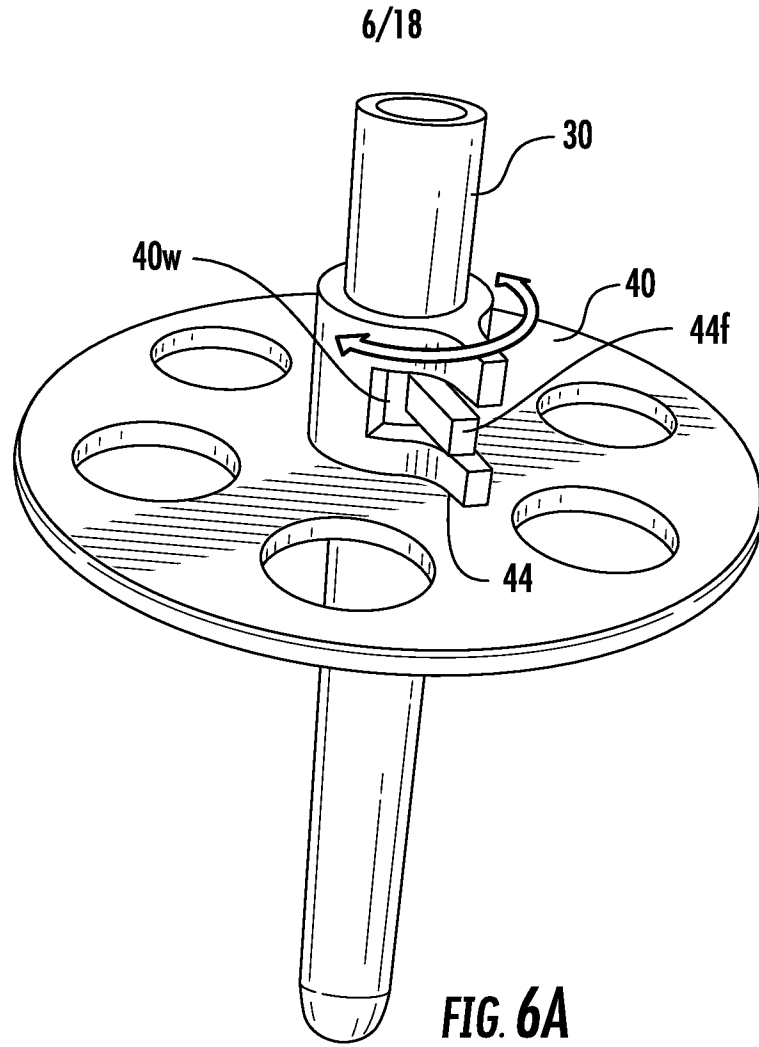
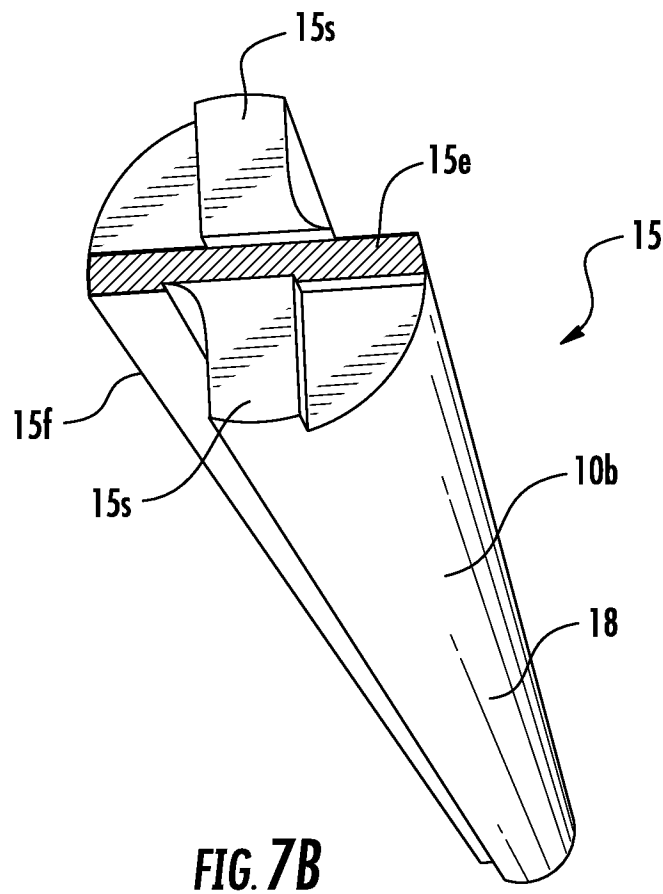
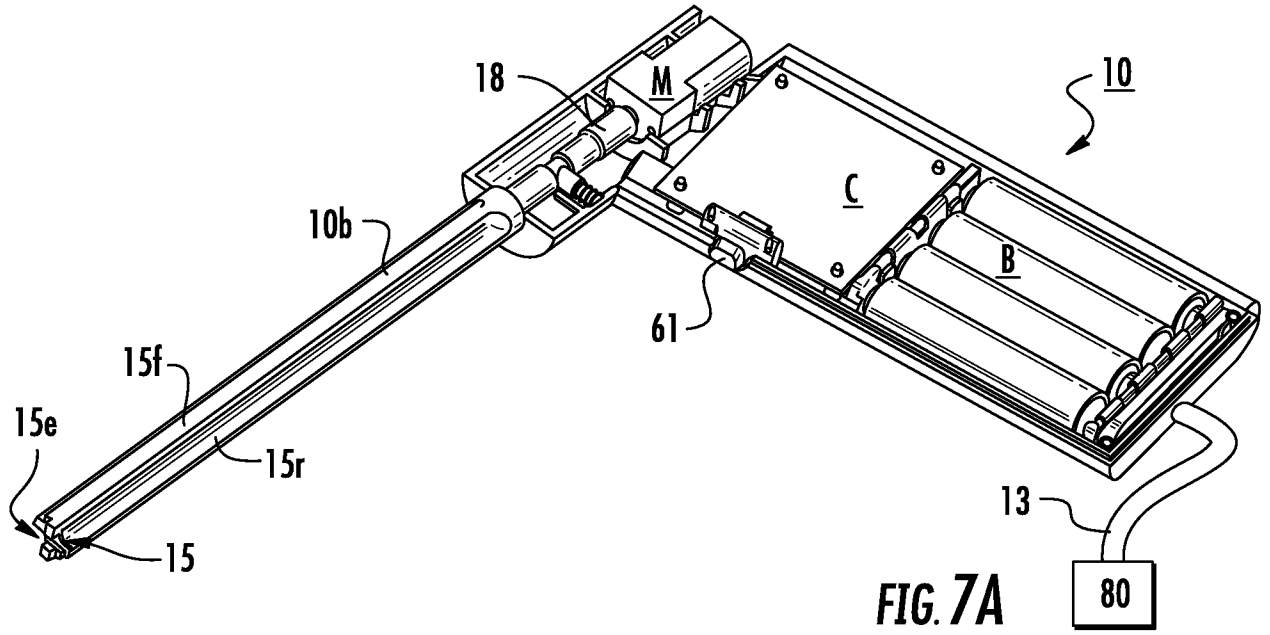
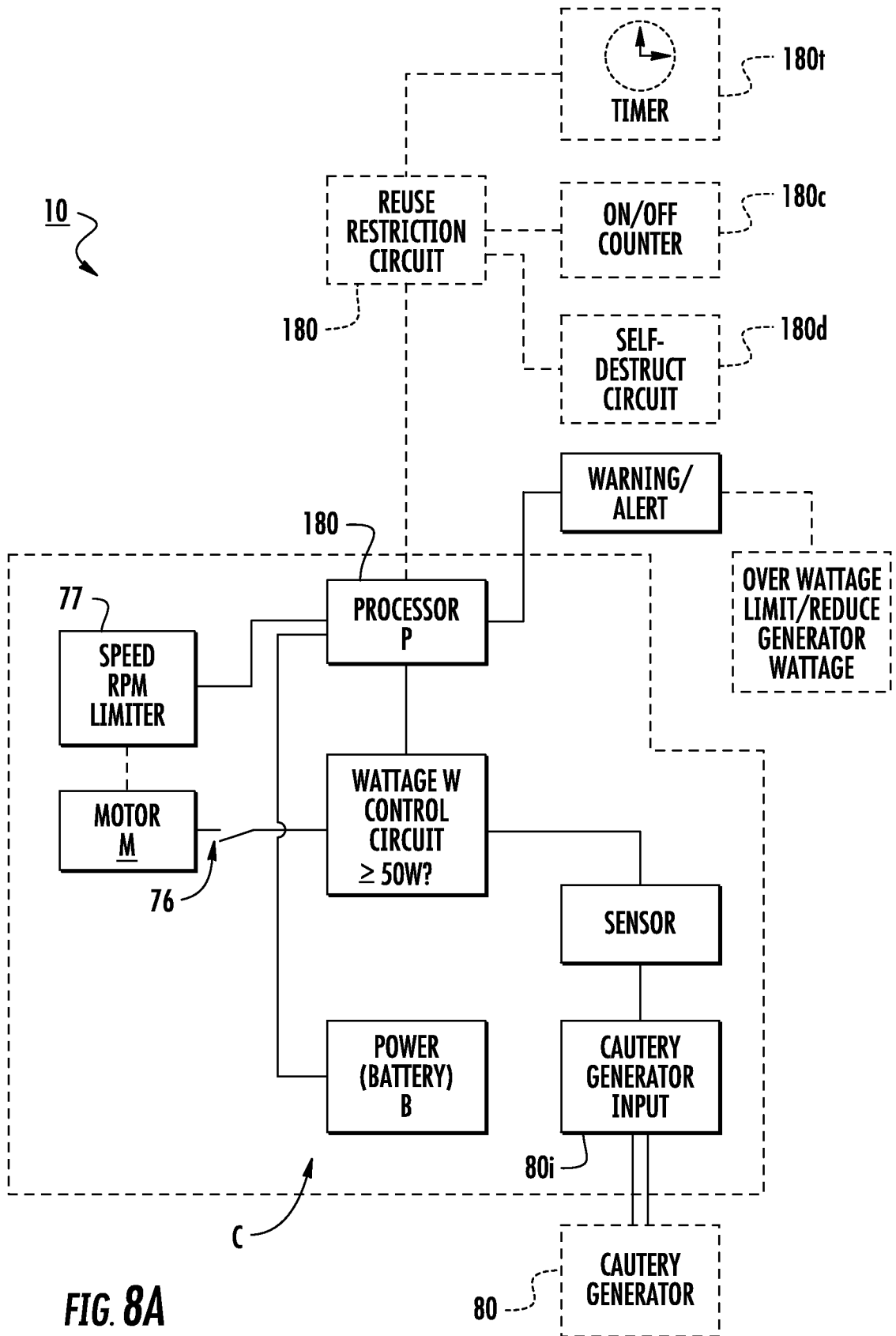
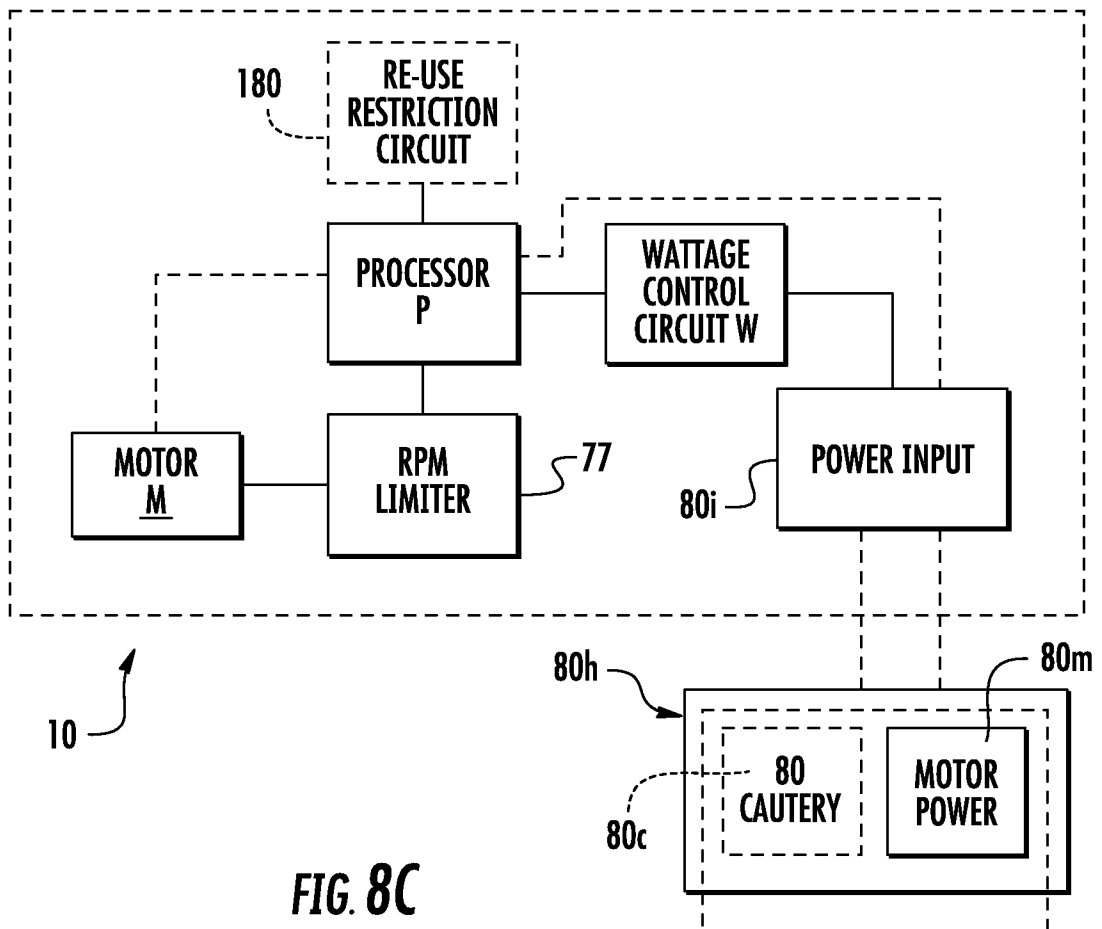
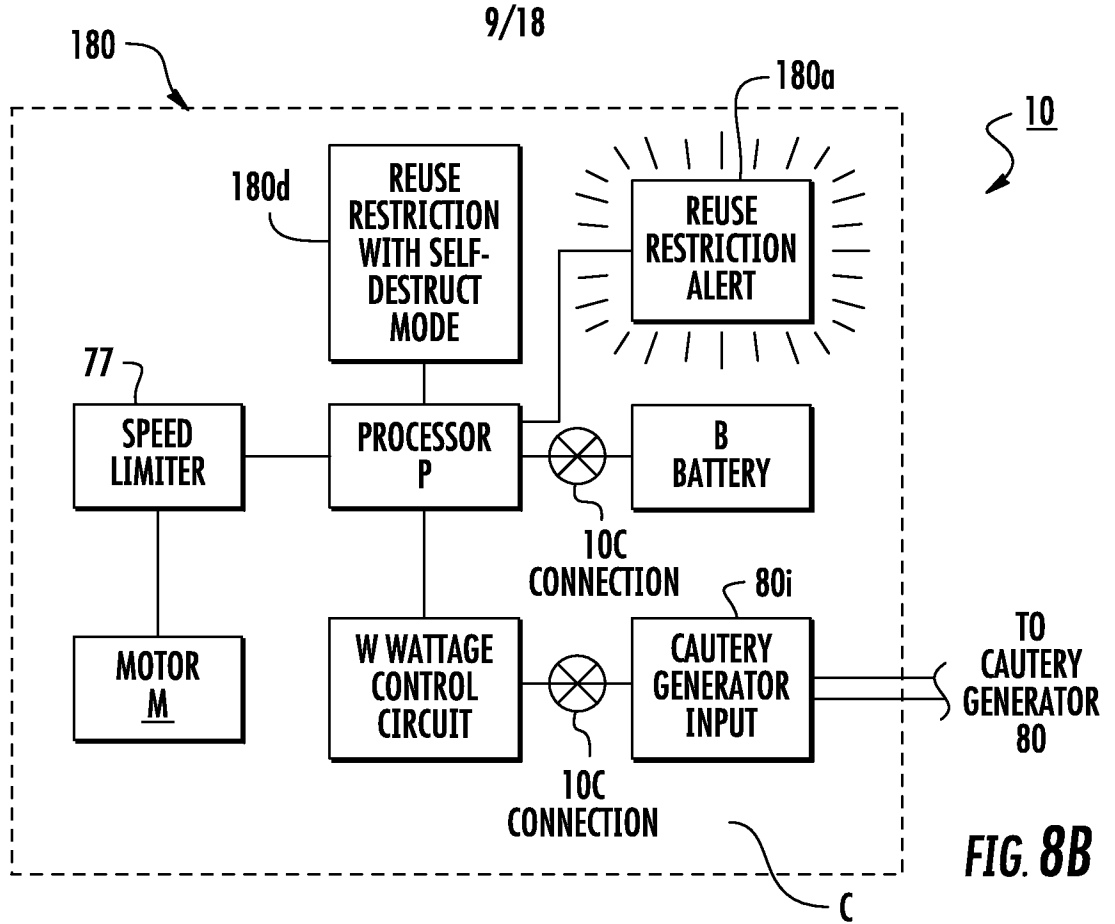

FIG. 5D









10/18

<u>CURVE</u>	<u>V</u>	<u>mA</u>	<u>W</u>
1	180	1000	40
2	200	1000	40
3	220	1000	40

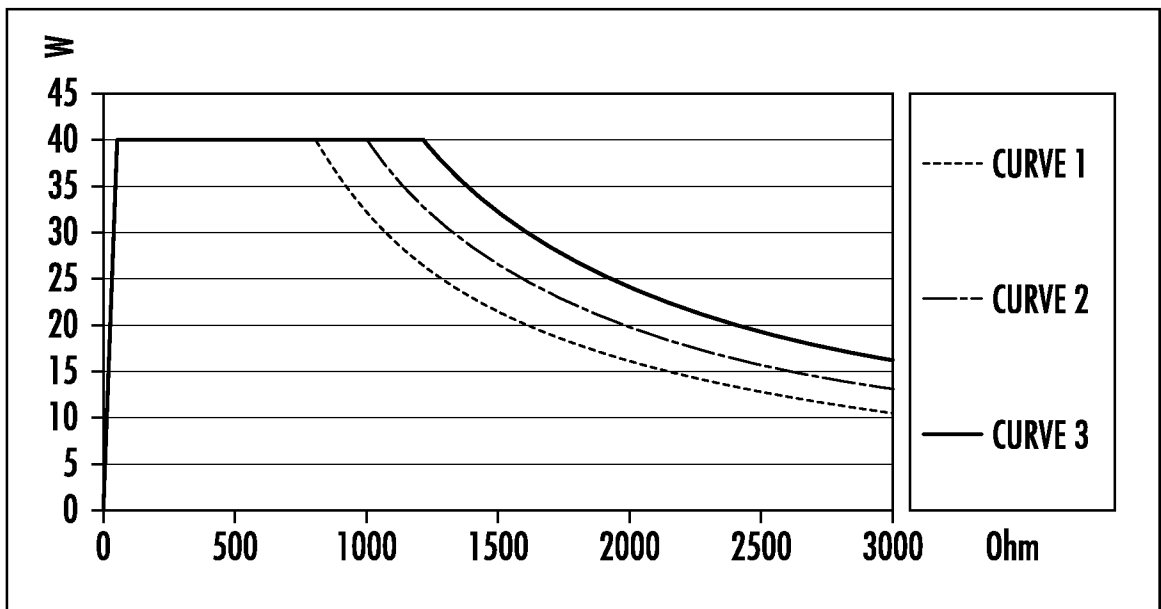
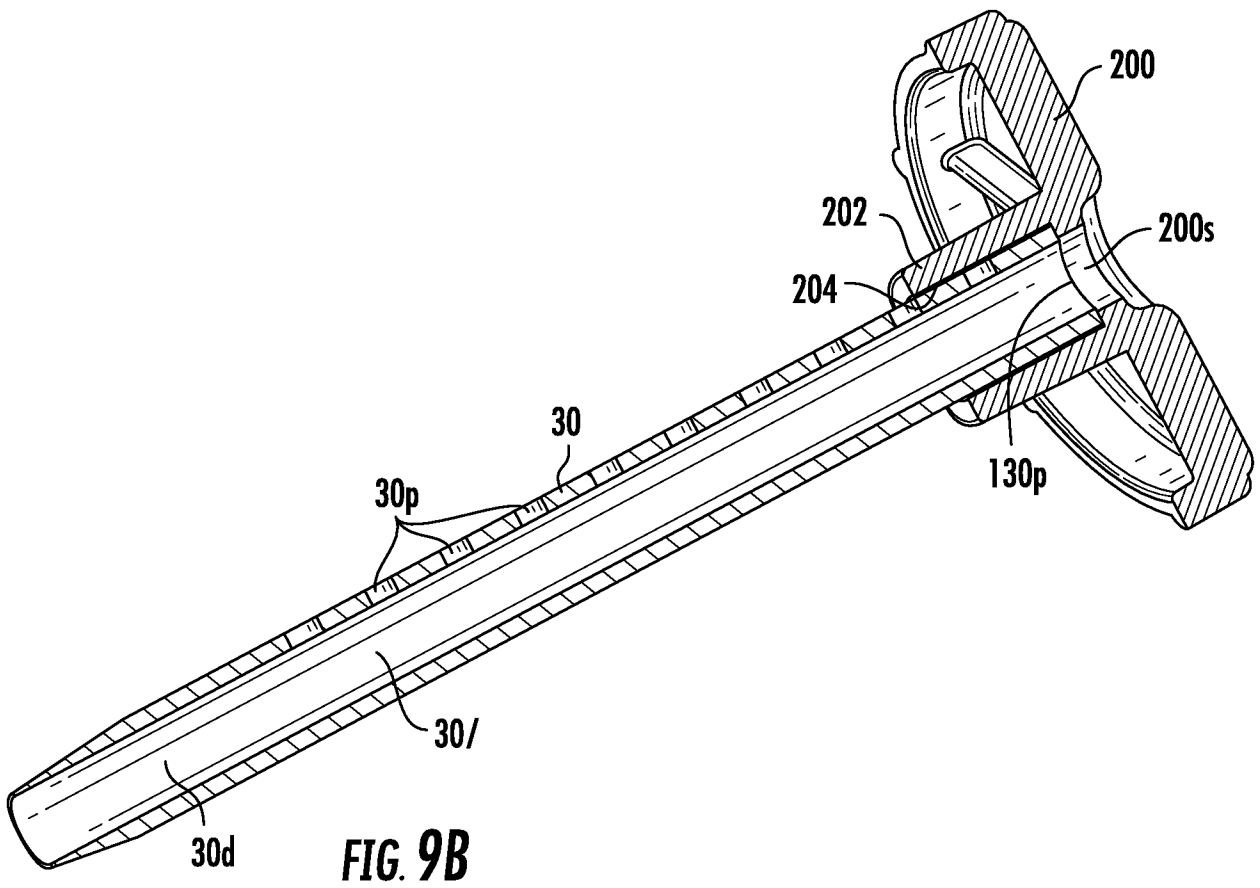
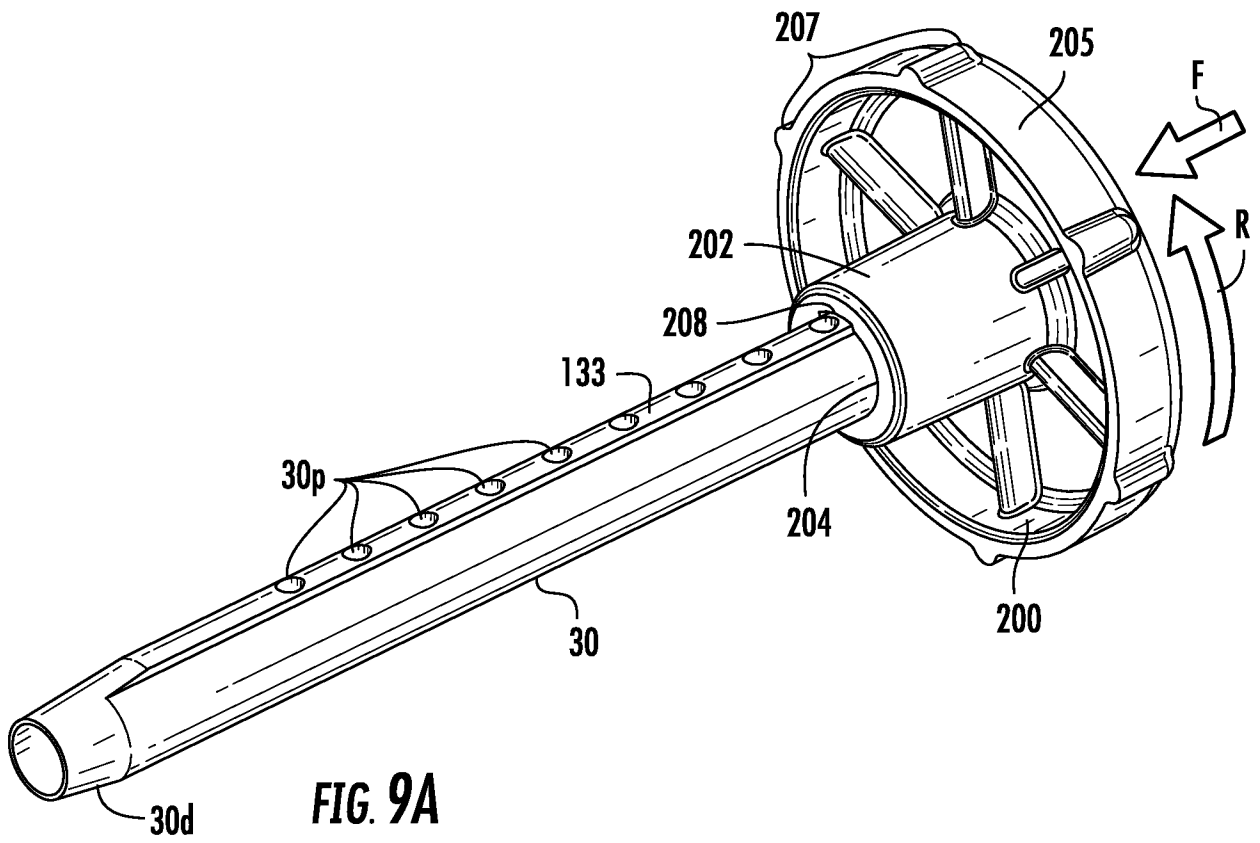
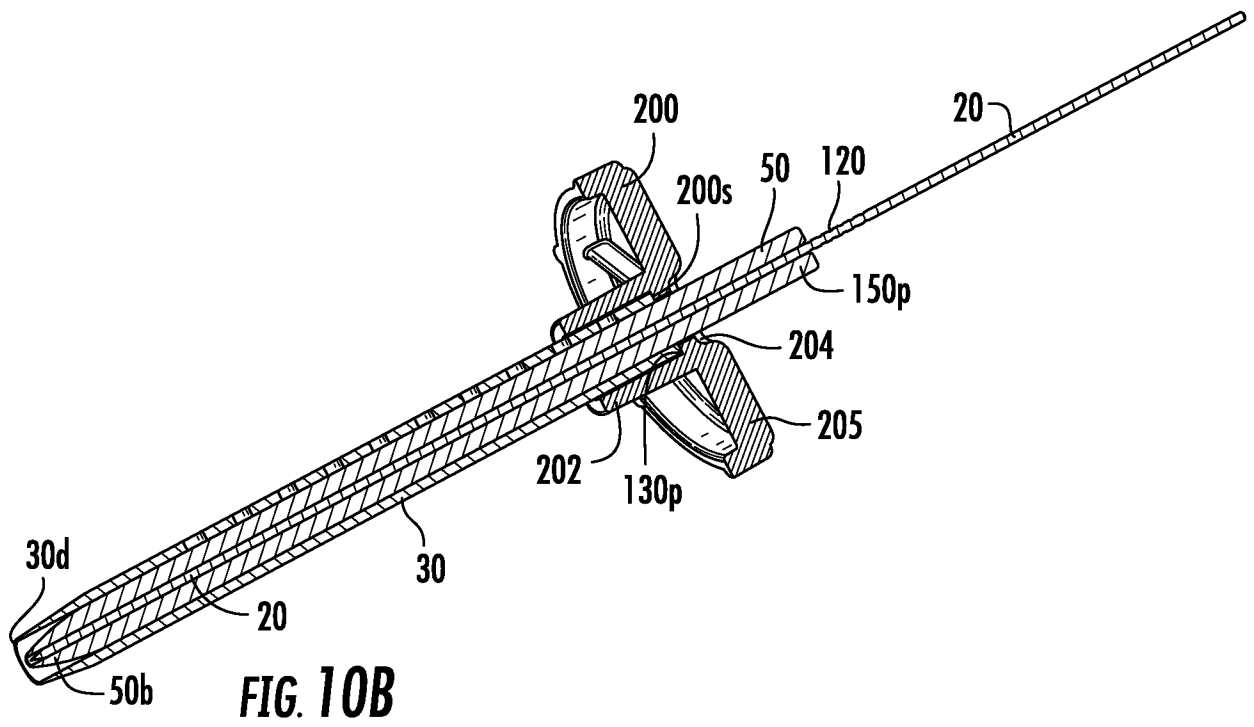
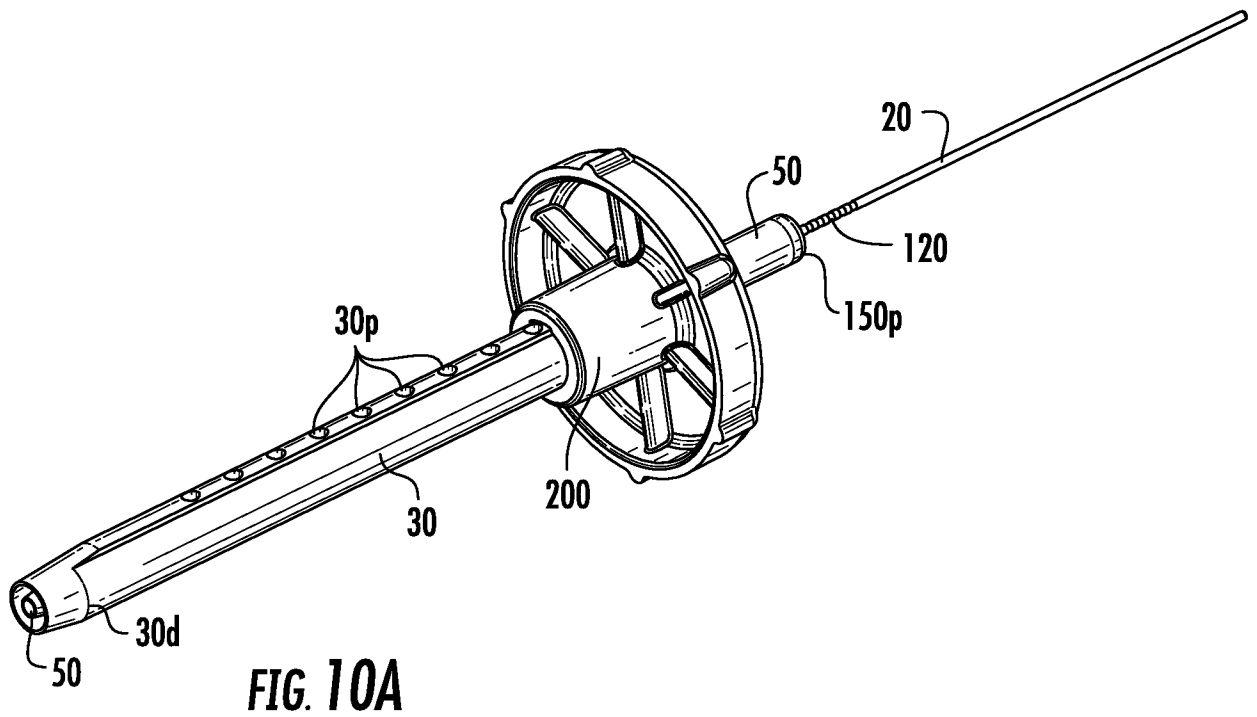

FIG. 8D





13/18

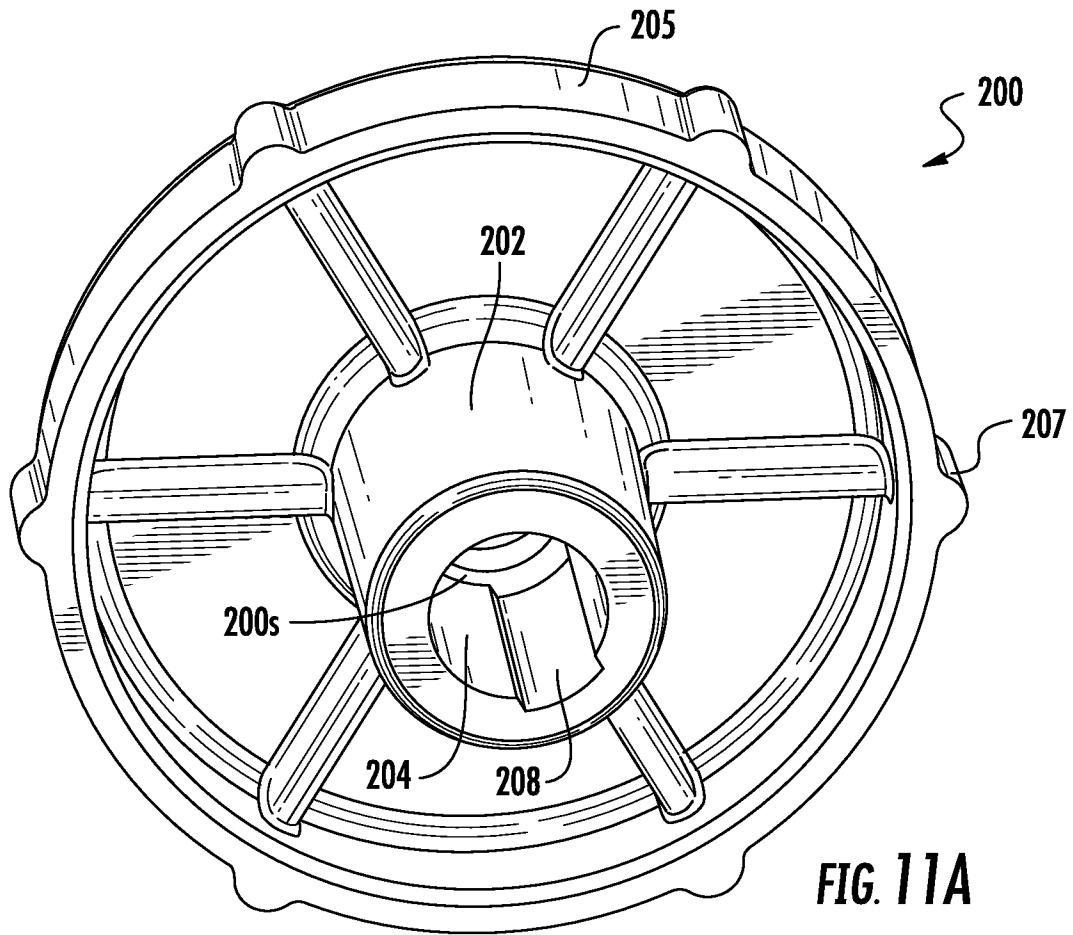

FIG. 11A

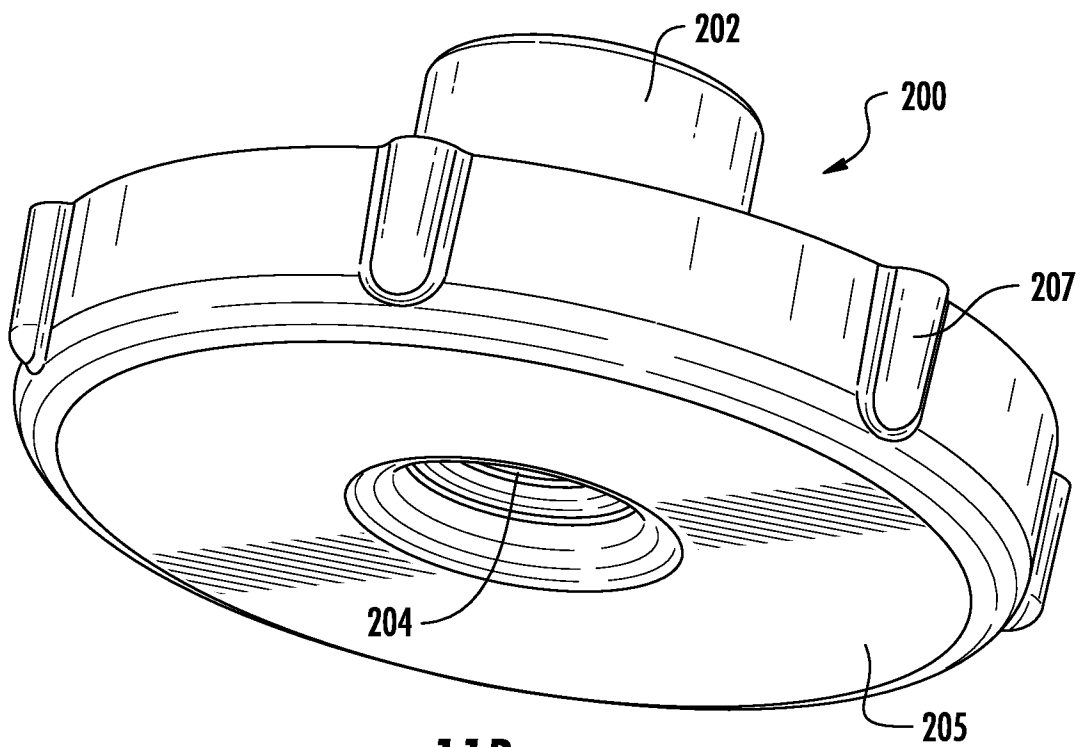

FIG. 11B

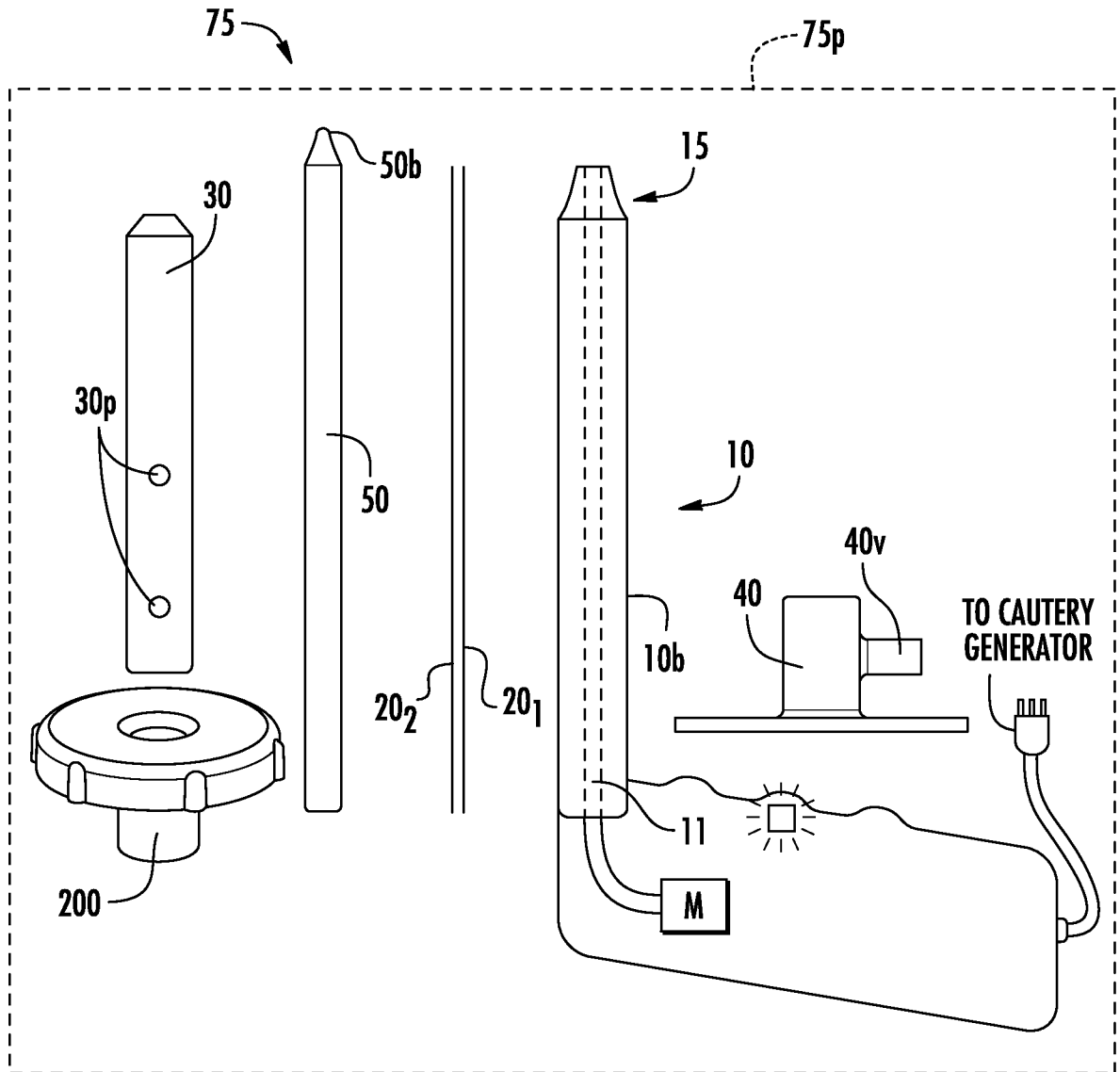

FIG. 12

15/18

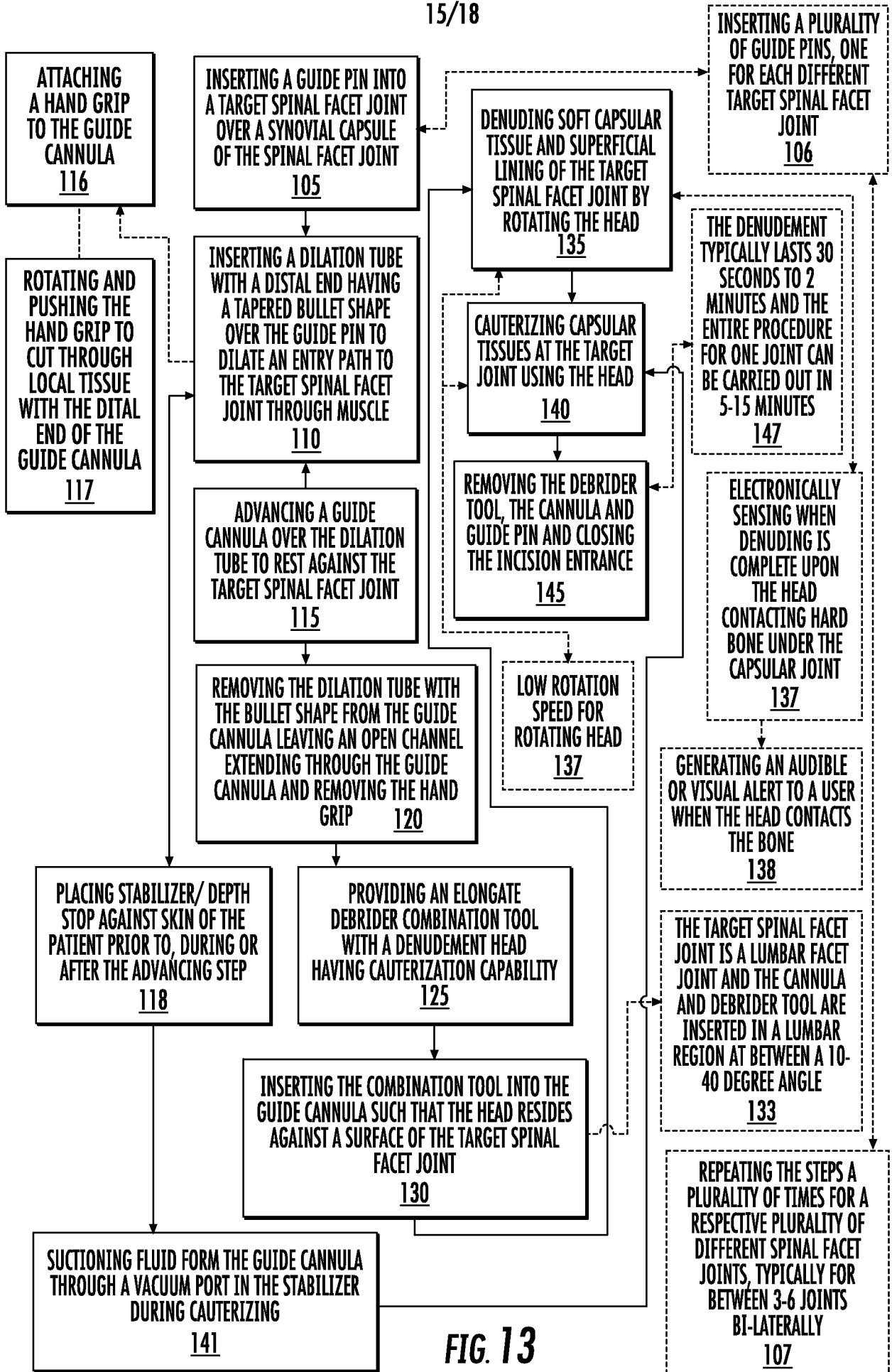
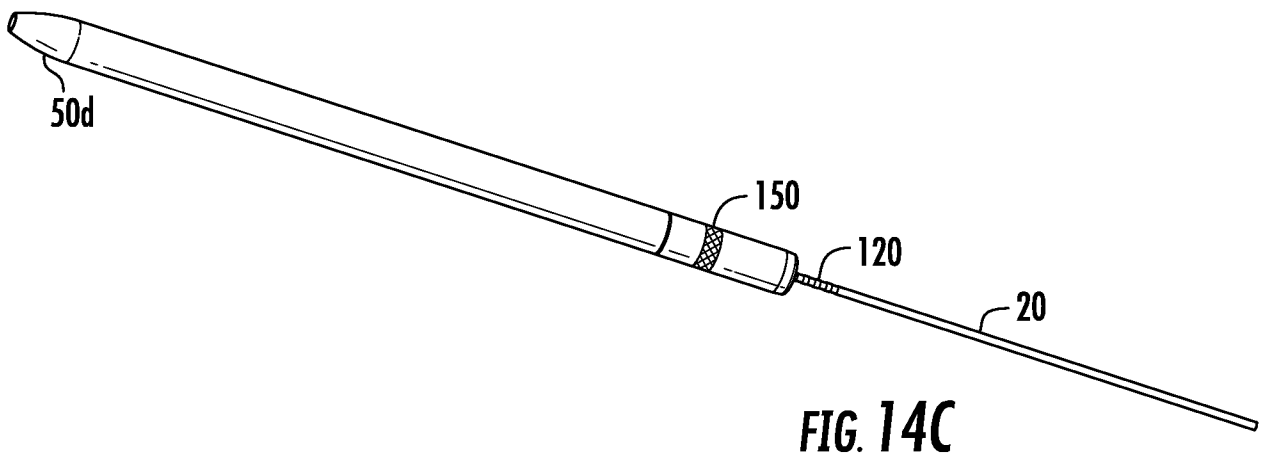
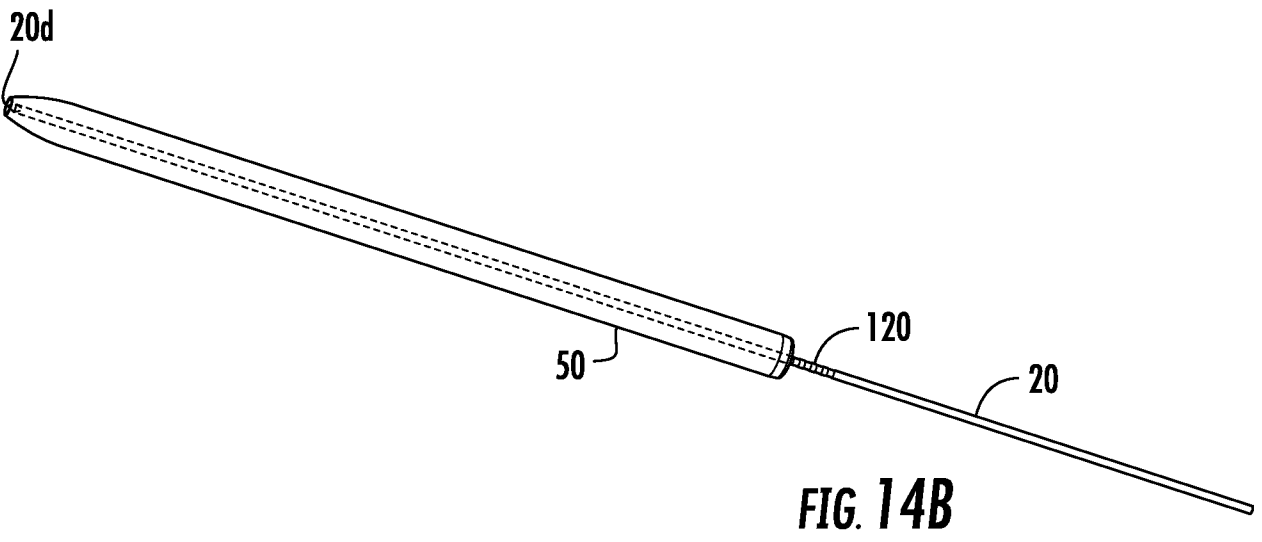
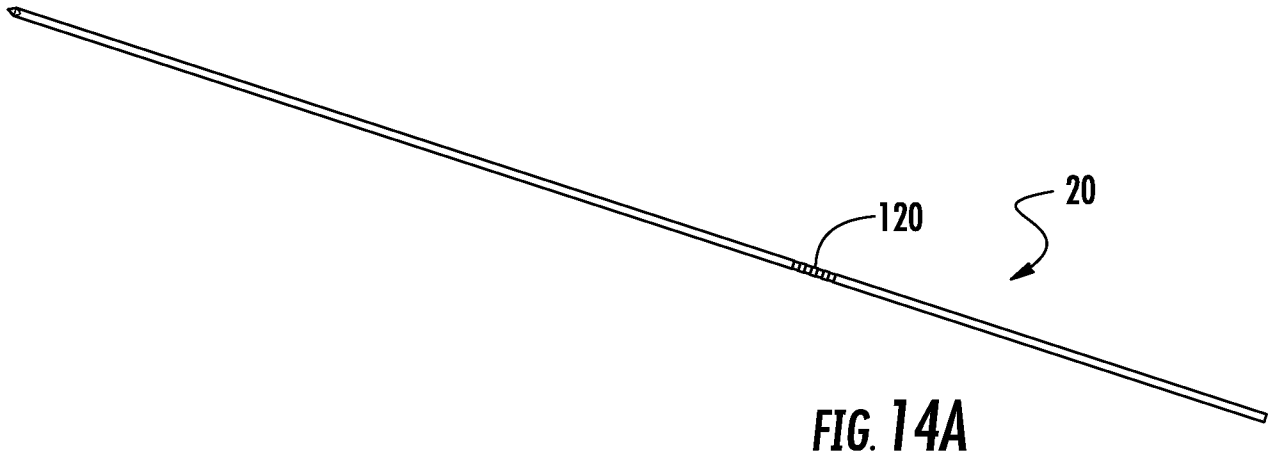

FIG. 13



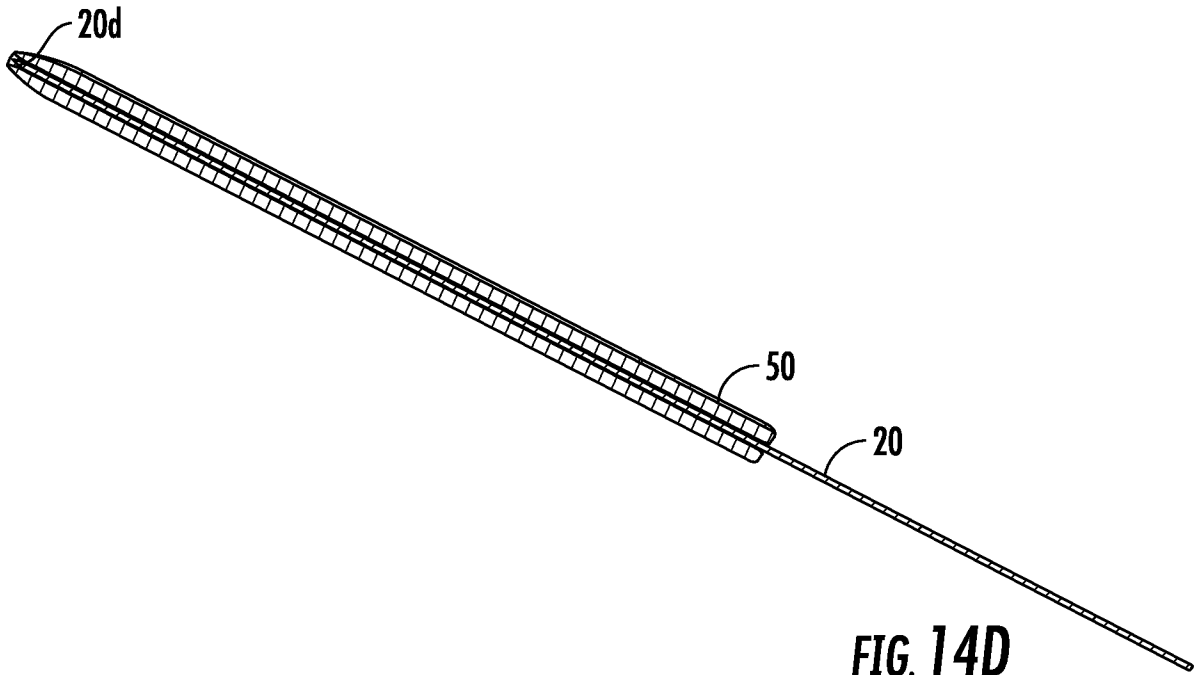

FIG. 14D

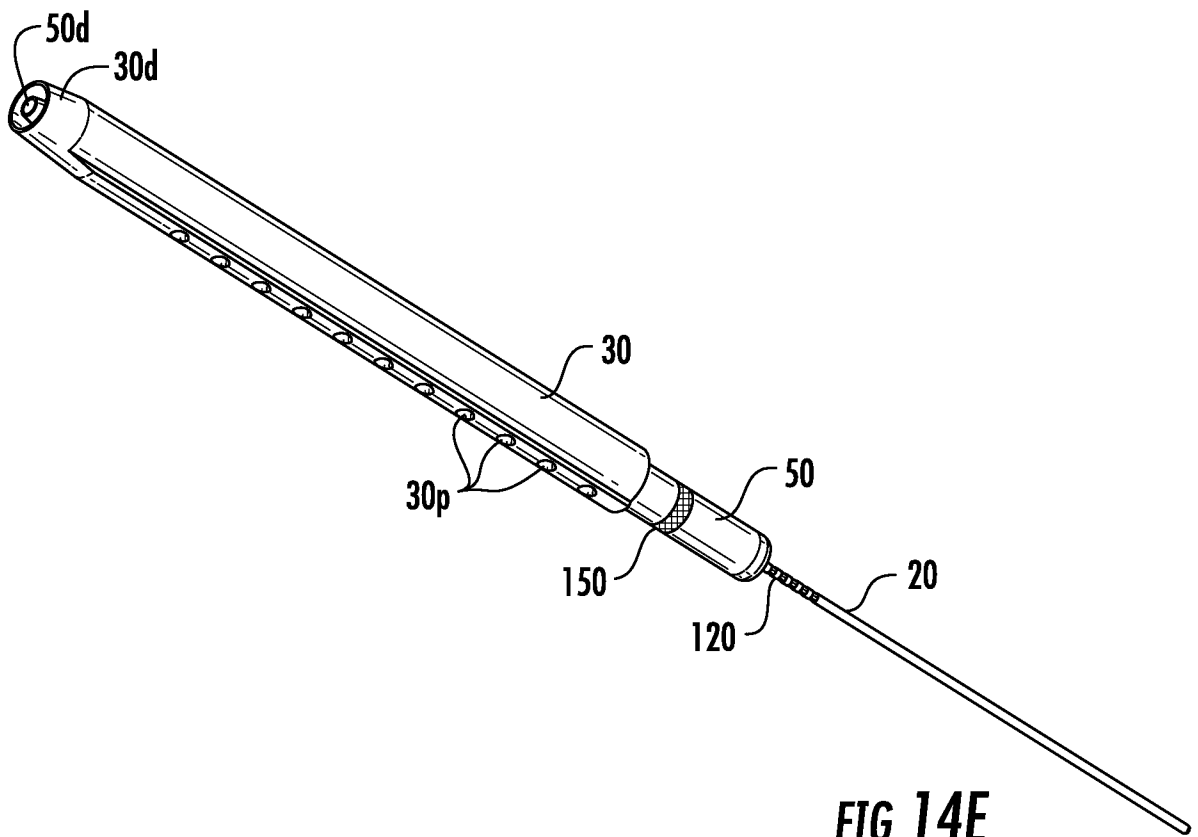
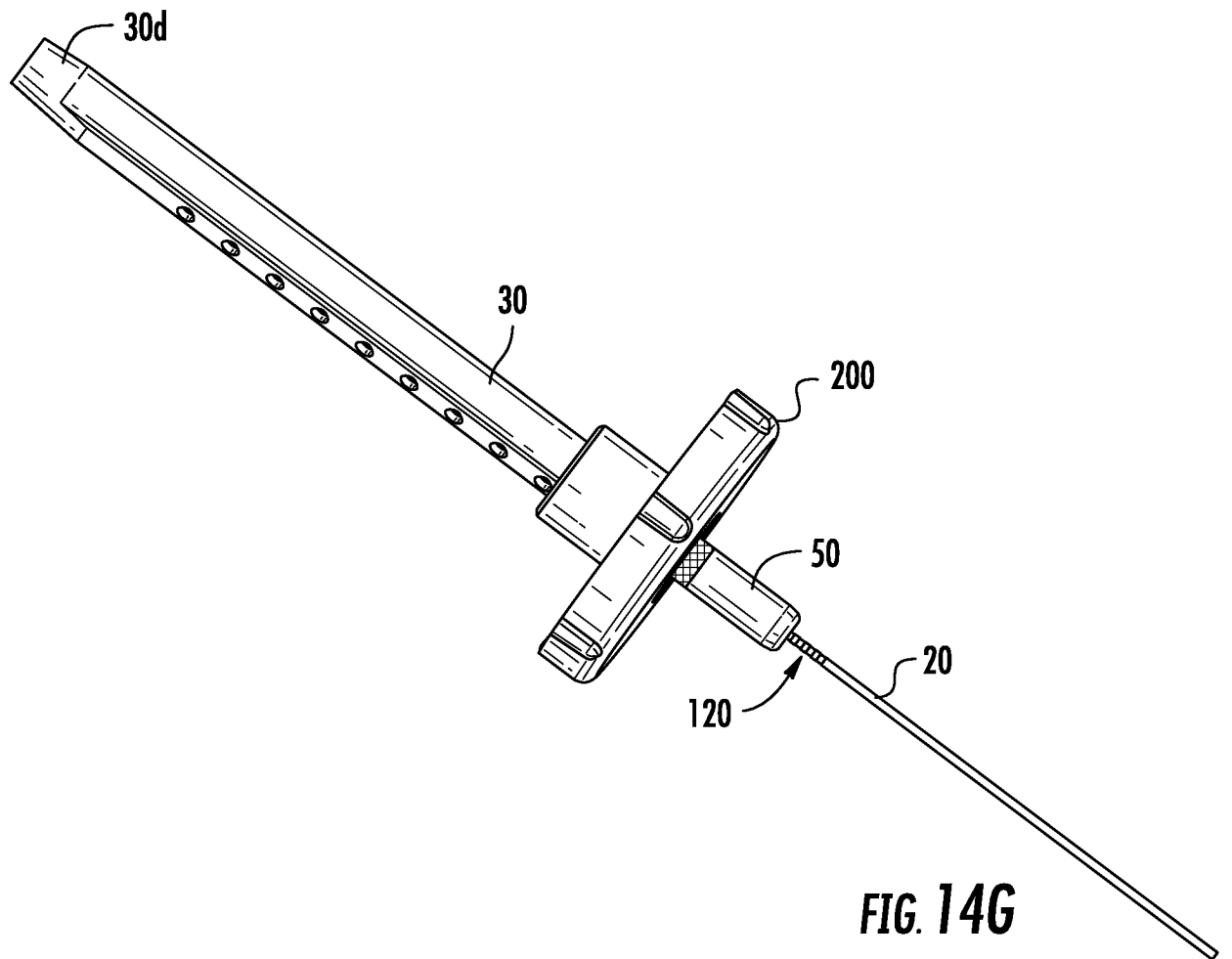
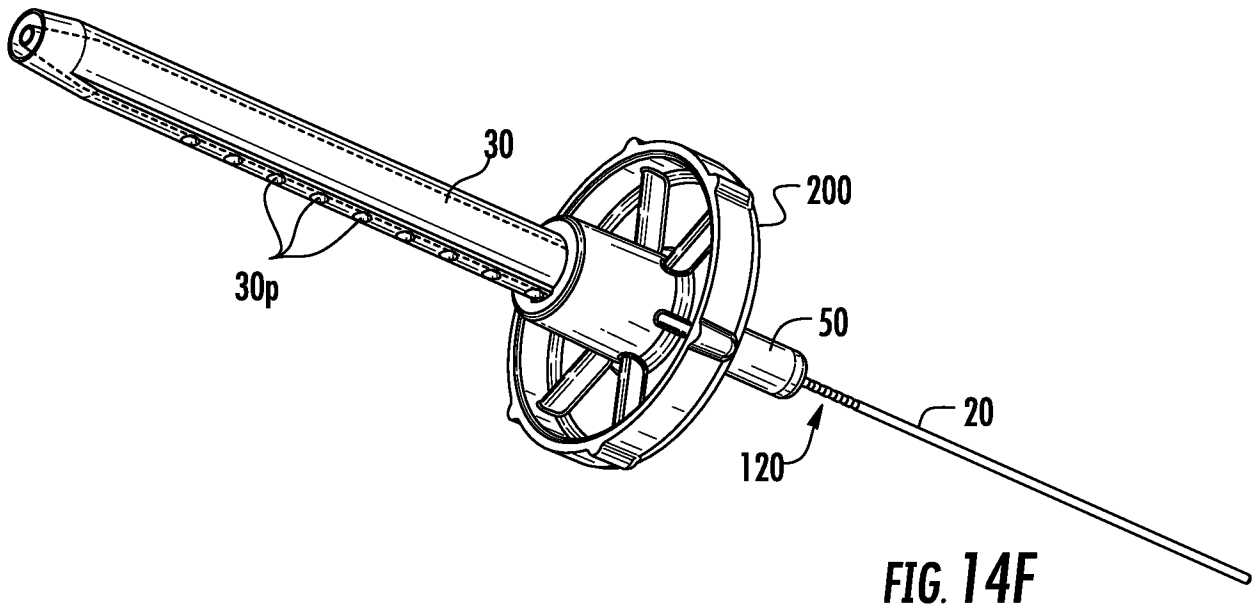

FIG. 14E



INTERNATIONAL SEARCH REPORT

International application No
PCT/US2015/040867

A. CLASSIFICATION OF SUBJECT MATTER
INV. A61B17/16 A61B17/34 A61B17/32 A61B18/12
ADD.
According to International Patent Classification (IPC) or to both national classification and IPC

B. FIELDS SEARCHED
Minimum documentation searched (classification system followed by classification symbols)
A61B
Documentation searched other than minimum documentation to the extent that such documents are included in the fields searched

Electronic data base consulted during the international search (name of data base and, where practicable, search terms used)
EPO-Internal, WPI Data

C. DOCUMENTS CONSIDERED TO BE RELEVANT

Category*	Citation of document, with indication, where appropriate, of the relevant passages	Relevant to claim No.
X	US 5 865 810 A (PERRY LARRY C [US] ET AL) 2 February 1999 (1999-02-02) column 4, line 1 - column 5, line 16; figures 1-2B	19
Y	US 2006/178670 A1 (WOLOSZKO JEAN [US] ET AL) 10 August 2006 (2006-08-10) paragraphs [0006], [0008], [0018], [0040], [0041], [0053], [0054] paragraphs [0073] - [0083]; figures 4-5F	22
A		24-27,32
Y	US 2001/000531 A1 (CASSCELLS CHRISTOPHER D [US] ET AL) 26 April 2001 (2001-04-26) paragraphs [0021] - [0024], [0040] - [0048], [0052] - [0056]; figures 1A, 4, 5A, 6A, 6B	22
	----- -/--	

Further documents are listed in the continuation of Box C.

See patent family annex.

* Special categories of cited documents :

- "A" document defining the general state of the art which is not considered to be of particular relevance
- "E" earlier application or patent but published on or after the international filing date
- "L" document which may throw doubts on priority claim(s) or which is cited to establish the publication date of another citation or other special reason (as specified)
- "O" document referring to an oral disclosure, use, exhibition or other means
- "P" document published prior to the international filing date but later than the priority date claimed

- "T" later document published after the international filing date or priority date and not in conflict with the application but cited to understand the principle or theory underlying the invention
- "X" document of particular relevance; the claimed invention cannot be considered novel or cannot be considered to involve an inventive step when the document is taken alone
- "Y" document of particular relevance; the claimed invention cannot be considered to involve an inventive step when the document is combined with one or more other such documents, such combination being obvious to a person skilled in the art
- "&" document member of the same patent family

Date of the actual completion of the international search

3 December 2015

Date of mailing of the international search report

04/01/2016

Name and mailing address of the ISA/

European Patent Office, P.B. 5818 Patentlaan 2
NL - 2280 HV Rijswijk
Tel. (+31-70) 340-2040,
Fax: (+31-70) 340-3016

Authorized officer

Friedrich, Franz

INTERNATIONAL SEARCH REPORT

International application No.
PCT/US2015/040867

Box No. II Observations where certain claims were found unsearchable (Continuation of item 2 of first sheet)

This international search report has not been established in respect of certain claims under Article 17(2)(a) for the following reasons:

1. Claims Nos.: 1-11
because they relate to subject matter not required to be searched by this Authority, namely:

2. Claims Nos.:
because they relate to parts of the international application that do not comply with the prescribed requirements to such an extent that no meaningful international search can be carried out, specifically:

3. Claims Nos.:
because they are dependent claims and are not drafted in accordance with the second and third sentences of Rule 6.4(a).

Box No. III Observations where unity of invention is lacking (Continuation of item 3 of first sheet)

This International Searching Authority found multiple inventions in this international application, as follows:

see additional sheet

1. As all required additional search fees were timely paid by the applicant, this international search report covers all searchable claims.

2. As all searchable claims could be searched without effort justifying an additional fees, this Authority did not invite payment of additional fees.

3. As only some of the required additional search fees were timely paid by the applicant, this international search report covers only those claims for which fees were paid, specifically claims Nos.:

4. No required additional search fees were timely paid by the applicant. Consequently, this international search report is restricted to the invention first mentioned in the claims; it is covered by claims Nos.:

Remark on Protest

- The additional search fees were accompanied by the applicant's protest and, where applicable, the payment of a protest fee.
- The additional search fees were accompanied by the applicant's protest but the applicable protest fee was not paid within the time limit specified in the invitation.
- No protest accompanied the payment of additional search fees.

INTERNATIONAL SEARCH REPORT

International application No
PCT/US2015/040867

C(Continuation). DOCUMENTS CONSIDERED TO BE RELEVANT		
Category*	Citation of document, with indication, where appropriate, of the relevant passages	Relevant to claim No.
A	US 5 569 290 A (MCAFFEE PAUL C [US]) 29 October 1996 (1996-10-29) column 1, line 8 - line 22; figures 1-6 column 4, line 27 - line 35 column 5, line 38 - line 45 column 6, line 36 - column 7, line 13 -----	12,19,24
A	US 2010/145142 A1 (BEGEMANN MALCOLM JON SIMON [NL] ET AL) 10 June 2010 (2010-06-10) paragraphs [0032], [0037], [0071], [0074], [0075], [0086] - [0087], [0089], [0126], [0145]; figures 1-5 -----	12-21, 24,28-31
A	US 2 001 638 A (ELOF TORNSJO GUSTAF) 14 May 1935 (1935-05-14) the whole document -----	12,19,24
A	US 2003/153926 A1 (SCHMIEDING REINHOLD [US] ET AL) 14 August 2003 (2003-08-14) paragraphs [0027] - [0035]; figures 1-5,7 -----	12,19,24
A	US 2003/195392 A1 (HAMEL ROSS J [US] ET AL) 16 October 2003 (2003-10-16) paragraphs [0018], [0064] - [0083]; figures 1, 2A, 3, 5, 6 -----	15-17, 21,28-30
A	US 2002/165549 A1 (OWUSU-AKYAW SAMUEL [US] ET AL) 7 November 2002 (2002-11-07) paragraphs [0003], [0009], [0014], [0039] - [0049], [0093] - [0094]; figures 1,2,19 -----	22
A	WO 97/33523 A1 (MEDICAL SCIENT INC [US]; NARDELLA PAUL C [US]; CVINAR JOHN F [US]; WRU) 18 September 1997 (1997-09-18) page 6; figures 1, 1A -----	22,24
A	US 6 142 992 A (CHENG ANDREW M L [US] ET AL) 7 November 2000 (2000-11-07) cited in the application the whole document -----	22,24-27
A	US 2014/100567 A1 (EDWARDS KEVIN C [US] ET AL) 10 April 2014 (2014-04-10) paragraphs [0047], [0063] - [0064]; figures 8A-8C -----	22,24
A,P	WO 2014/176141 A2 (MEDOVEX CORP [US]) 30 October 2014 (2014-10-30) the whole document -----	12-21, 24,28-31

INTERNATIONAL SEARCH REPORT

Information on patent family members

International application No

PCT/US2015/040867

Patent document cited in search report	Publication date	Patent family member(s)	Publication date
US 5865810	A	02-02-1999	AU 690865 B2 30-04-1998
			AU 1019597 A 24-07-1997
			BR 9700699 A 03-11-1998
			CA 2194514 A1 20-07-1997
			EP 0788803 A2 13-08-1997
			JP H09294745 A 18-11-1997
			US 5651773 A 29-07-1997
			US 5865810 A 02-02-1999
US 2006178670	A1	10-08-2006	EP 1651127 A2 03-05-2006
			US 2006178670 A1 10-08-2006
			WO 2005009213 A2 03-02-2005
US 2001000531	A1	26-04-2001	AU 9571198 A 05-04-1999
			US 6214001 B1 10-04-2001
			US 2001000531 A1 26-04-2001
			WO 9913788 A1 25-03-1999
US 5569290	A	29-10-1996	NONE
US 2010145142	A1	10-06-2010	EP 2174602 A1 14-04-2010
			EP 2537478 A1 26-12-2012
			US 2010145142 A1 10-06-2010
US 2001638	A	14-05-1935	NONE
US 2003153926	A1	14-08-2003	NONE
US 2003195392	A1	16-10-2003	AT 460878 T 15-04-2010
			AU 2003297867 A1 30-06-2004
			BR 0317182 A 25-10-2005
			CA 2508789 A1 24-06-2004
			CN 1764410 A 26-04-2006
			EP 1605809 A2 21-12-2005
			EP 2151186 A1 10-02-2010
			ES 2343111 T3 23-07-2010
			JP 2006508755 A 16-03-2006
			KR 20050109916 A 22-11-2005
			NZ 541160 A 24-12-2008
			US 2003195392 A1 16-10-2003
			US 2005192486 A1 01-09-2005
			WO 2004052180 A2 24-06-2004
			ZA 200504864 A 30-05-2007
US 2002165549	A1	07-11-2002	NONE
WO 9733523	A1	18-09-1997	AU 2201197 A 01-10-1997
			US 5941876 A 24-08-1999
			WO 9733523 A1 18-09-1997
			ZA 9702086 A 23-06-1998
US 6142992	A	07-11-2000	US 6142992 A 07-11-2000
			US 6296636 B1 02-10-2001
US 2014100567	A1	10-04-2014	CN 103857354 A 11-06-2014
			EP 2731533 A1 21-05-2014
			JP 5813245 B2 17-11-2015
			JP 2014534874 A 25-12-2014

INTERNATIONAL SEARCH REPORT

Information on patent family members

International application No

PCT/US2015/040867

Patent document cited in search report	Publication date	Patent family member(s)	Publication date
		US 2014100567 A1	10-04-2014
		WO 2014055131 A1	10-04-2014

WO 2014176141 A2	30-10-2014	AU 2014257302 A1	15-10-2015
		CN 104116555 A	29-10-2014
		CN 204394669 U	17-06-2015
		CN 204723157 U	28-10-2015
		HK 1203342 A1	30-10-2015
		US 2014324044 A1	30-10-2014
		WO 2014176141 A2	30-10-2014

FURTHER INFORMATION CONTINUED FROM PCT/ISA/ 210

This International Searching Authority found multiple (groups of) inventions in this international application, as follows:

1. claims: 12-21, 28-31(completely); 24(partially)

Guide cannula with stabilizer for attachment to the skin surface enabling venting of a surgical situ

2. claims: 22, 23, 25-27, 32(completely); 24(partially)

Electrosurgical tool with combined rotary mechanical and cautery ablation of spinal tissue
