



(12) **EUROPEAN PATENT APPLICATION**

(43) Date of publication:  
**18.06.2014 Bulletin 2014/25**

(51) Int Cl.:  
**A47K 10/32 (2006.01)**

(21) Application number: **13196913.1**

(22) Date of filing: **12.12.2013**

(84) Designated Contracting States:  
**AL AT BE BG CH CY CZ DE DK EE ES FI FR GB GR HR HU IE IS IT LI LT LU LV MC MK MT NL NO PL PT RO RS SE SI SK SM TR**  
 Designated Extension States:  
**BA ME**

(71) Applicant: **de Groot, Cornelis Robert**  
**1333 GV Almere (NL)**

(72) Inventor: **de Groot, Cornelis Robert**  
**1333 GV Almere (NL)**

(74) Representative: **Altenburg, Bernardus Stephanus Franciscus**  
**Altenburg Patent**  
**Ravelijnstraat 125**  
**4102 AJ Culemborg (NL)**

(30) Priority: **12.12.2012 NL 2009970**  
**13.02.2013 NL 2010297**  
**16.08.2013 NL 2011312**

(54) **A device for supplying absorbing paper**

(57) The invention relates to a device (100) for moistening absorbing paper, such as toilet paper or kitchen paper (398). The device (100) comprises  
 - a liquid reservoir (110), and  
 - a wettable roll (111) which is rotatably mounted and is at least partly incorporated in the liquid reservoir (110).

There is a movable lid for the liquid reservoir (110) that acts as a guiding plate (220), whereby depending on the choice of the user i) non-moistened absorbing paper, and ii) moistened absorbing paper can be delivered.

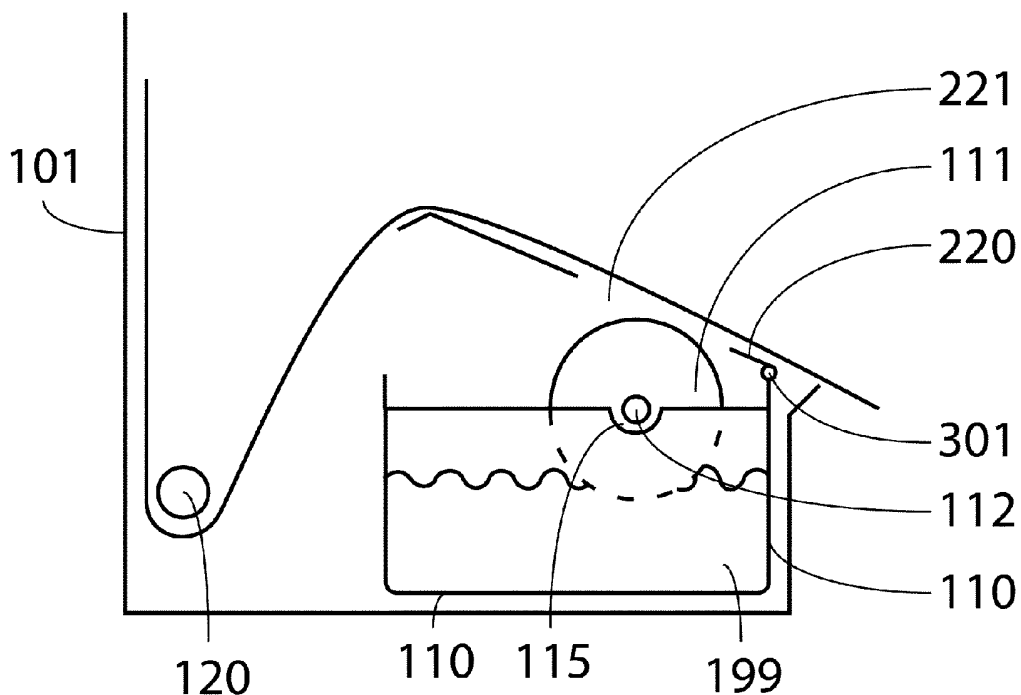

**Fig. 3A**

## Description

**[0001]** The present invention relates to device for supplying absorbing paper of a roll, which device comprises

- a liquid reservoir, and
- a wettable roll which is mounted rotatably and is at least partly received in the liquid reservoir,

and the absorbing paper during the unwinding of the roll can be led into contact with the wettable roll wherein the wettable roll rotates and can supply liquid from the liquid reservoir to the absorbing paper, wherein the device is arranged for supplying i) non-moistened absorbing paper, and ii) moistened absorbing paper as desired by the user.

**[0002]** Devices for delivering absorbing paper, especially for delivering paper from a toilet roll or a kitchen roll, are generally known in the art. A full roll of toilet paper or a full kitchen roll has a diameter of 9 cm or more, and the device as known in the art is suitable for rotatably holding such a full roll. It is a problem that for some forms of use the absorbing paper feels unpleasant and/or has insufficient cleansing capacity. In the art this problem is solved by means of a device with which depending on the user's choice moistened or dry absorbing paper can be supplied. A device according to the preamble is in particular known from WO9208403, in which the liquid reservoir is covered in order to counteract evaporation of liquid from the reservoir.

**[0003]** The object of the present application is to provide an alternative device according to the preamble.

**[0004]** To this end, a device according to the preamble is characterized in that the device has a guiding plate which provides a window, the guiding plate acts as a lid of the liquid reservoir, and the guiding plate can be in a first position and in a second position, wherein

- in the first position the wettable roll does not protrude through the window for permitting the supply of non-moistened absorbing paper, and
- in the second position the wettable roll protrudes partly through the window for permitting the supply of moistened absorbing paper.

**[0005]** Prior to the use of the device the liquid reservoir is provided with water or an aqueous solution. Thus, for example when visiting the toilet a user can opt for moistened toilet paper for more comfort or for traditional dry toilet paper. The guiding plate is a guide for the absorbing paper. Thus, the trajectory followed by the paper is determined by the guiding plate, and the position of the guiding plate determines whether the absorbing paper delivered by the device can be moistened. In comparison with the device known from WO9208403, with the device according to the invention it can be avoided in a simple way that after the last user of paper, the paper rests on the wettable roll and thereby gets wet. In addition, the

absorbing paper that lies over the window may reduce the evaporation of water from the reservoir.

**[0006]** The present invention is especially suitable for moistening multilayered absorbing paper that has for instance two and preferably 3 or 4 layers. For supplying moistened toilet paper it may be favourable if the water contains emollients such as glycerol or the like. In the case of such an aqueous solution a preservative will also be present in order to prevent the growth of bacteria. The wettable roll is for instance made of plain wood, such as beech wood. In order to increase the amount of water taken up the wettable roll may be provided with wells. However, in general it will be preferred that the absorbing paper does not become wet (soaked). Therefore it is preferred that the wettable roll is only moistened at the surface thereof (no sponge effect). For a device for supplying toilet paper the wettable roll will have a maximum length of the moistening surface (measured in the axial direction of the wettable roll) of 16 cm, such as maximally 13 cm. In case the device serves to supply kitchen paper the wettable roll will have a maximum length of 28 cm, such as maximally 25 cm.

**[0007]** If the device serves to supply toilet paper it can be designated as a toilet roll holder. Such a device will be arranged for receiving a roll of toilet paper with a maximum height (measured in the axial direction of the roll) of 15 cm, such as maximally 12,5 cm. In case the device serves to supply kitchen paper it may be designated as a kitchen roll holder. Such a device will be arranged for receiving a roll of kitchen paper with a maximum height (measured in the axial direction of the roll) of 27,5 cm, such as maximally 25 cm. A device according to the invention does not have to be suitable, however, for holding the roll of absorbing paper itself, since the device can also be placed under a holder for a roll of absorbing paper, for instance suspended.

**[0008]** According to a favourable embodiment, the lowest point of the wettable roll is situated above the bottom of the liquid reservoir and the absorbing paper can be led over the upper side of the wettable roll.

**[0009]** Thus, a device is provided wherein leakproof sealing of the liquid reservoir against the wettable roll is not necessary and thus poses no problem. According to a possible embodiment the absorbing paper can be taken from the device at a distance above the wettable roll. In that case the device provides non-moistened (dry) absorbing paper. With the same device the absorbing paper can also be taken from the device with contact between the absorbing paper and the wettable roll. In that case the device provides moistened absorbing paper.

**[0010]** According to a favourable embodiment, the reservoir has a first tab; and the guiding plate has a second tab; and the guiding plate can be in a first position and in a second position, wherein

- the guiding plate in the first position can rest with second tab on the first tab and the wettable roll does not protrude through the window for permitting the

- supply of non-moistened absorbing paper, and
- in the second position the second tab is clicked over the first tab and the wettable roll protrudes partly through the window for permitting the supply of moistened absorbing paper.

**[0011]** Such a device is simple in use and can be manufactured relatively cheap.

**[0012]** According to a favourable embodiment, the device comprises a cover which is movable between a first position in which the guiding plate covers the wettable roll for permitting the supply of non-moistened absorbing paper, and a second position in which the cover exposes the wettable roll for permitting the supply of moistened absorbing paper.

**[0013]** The cover is for instance slidably or rotatably connected with the device.

**[0014]** According to a favourable embodiment, the device is arranged for rotatably holding a roll of the absorbing paper having a diameter of at least 9 cm.

**[0015]** Such a device is a holder for rotatably holding a roll of absorbing paper, for delivering the absorbing paper therewith.

**[0016]** According to a favourable embodiment, the device is arranged for non-freely rotatably holding a roll of absorbing paper.

**[0017]** Non-freely rotatably means that the roll does not continue rolling when in first instance the paper is pulled after which the pulling stops, i.e. that on the last moment the roll will no longer rotate.

**[0018]** According to a favourable embodiment, the wettable roll is hollow and is provided with an opening.

**[0019]** Thus, the capacity of the liquid reservoir is increased and it needs to be refilled less frequently. The opening will be situated outside of the trajectory of the absorbing paper, and is preferably provided in an end plane of the wettable roll. If the wettable roll is closed at one end, this can also be used for filling the liquid reservoir, whereby there will be no need to fully detach the device - which is for instance attached to a wall.

**[0020]** According to a favourable embodiment, the liquid reservoir is a liquid reservoir that can be detached from the device.

**[0021]** Thus, the liquid reservoir can be filled easily, for instance with tap water or distilled water.

**[0022]** According to a favourable embodiment, the device has a guiding organ that is suitable for guiding the absorbing paper before the absorbing paper can be supplied via a first path through the device not in contact with the wettable roll, and can be supplied moistened via a second path through the device in contact with the wettable roll.

**[0023]** This enables a relatively compact device (small foot-print), such as one wherein a roll of absorbing paper having a diameter of 10 cm is in a vertical downward projection at least partially overlapping the reservoir.

**[0024]** According to a favourable embodiment, the guiding organ is provided with a tear-off edge.

**[0025]** Thus, a sheet of moistened or non-moistened absorbing paper can be easily torn off after either moistening or not moistening. The tear-off edge can be a cutting edge, such of a knife, or a serrated edge, as of a serrated knife.

**[0026]** According to a favourable embodiment, wettable roll comprises a surface that is formed by closed cell-foam for moistening the paper that can be moistened.

**[0027]** With such a type of material a suitable degree of moistening can be ascertained by choosing the density thereof. An example of a suitable closed cell-foam is neoprene.

**[0028]** According to a favourable embodiment, the guiding plate has flange parts which extend downwardly transverse to the upper side.

**[0029]** Thus, an evaporation of liquid from the reservoir can also be reduced in the highest position of the guiding plate.

**[0030]** The present invention will now be illustrated with reference to the drawing where

Fig. 1a shows a side view of a holder provided with toilet paper in order to elucidate the background of the invention;

Fig. 1b shows a front view of a holder provided with toilet paper;

Fig. 2 shows an alternative embodiment of a holder for toilet paper in order to elucidate the background of the invention;

Fig. 3a and Fig. 3b show a device according to the invention for supplying kitchen paper;

Fig. 4 shows a hollow wettable roll for a holder;

Fig. 5a and Fig. 5b show an alternative embodiment of a device according to the invention in a first position respectively a second position;

Fig. 6 shows a reservoir suitable for a device according to the invention;

Fig. 7 shows a cross section through a housing of a holder without a liquid reservoir;

Fig. 8 shows a perspective view on a liquid reservoir without a lid;

Fig. 9 shows a perspective view on the lid of the liquid reservoir of Fig. 8 ; and

Fig. 10a and 10b show an alternative embodiment of a device according to the invention.

Fig. 1a schematically shows a side view of a device 100, here a holder 100 for toilet paper provided with a toilet roll 198. Fig. 1b shows the same holder in front view. In Fig. 1a the sidewalls of the holder 100 have been omitted.

**[0031]** The holder 100 shown in Fig. 1a comprises a housing 101 provided with a valve 102 with which the holder 100 is closed at the upper side and the toilet roll 198 is out of sight.

**[0032]** In the housing 101 a liquid reservoir 110 is placed. The liquid reservoir 110 can be taken from the housing 101 in order to fill it with water 199. This liquid

reservoir 110 could have been an integral part of the device 100. It could then for instance be filled using a watering can, or the holder 100 could be picked up and be held with the liquid reservoir 110 under a faucet.

**[0033]** The liquid reservoir 110 is provided with a wettable roll 111 which has co-axial cams 112 and is rotatably carried with the mentioned cams 112 in recesses 115 of the liquid reservoir 110. The wettable roll 111 is for instance made of beech wood. Advantageously, however, the wettable roll 111 is made of a closed cell-foam, such as neoprene. For a durable roll ABS can be chosen.

**[0034]** The holder 100 is provided with a guiding organ 120, here a guiding rod 120, the function of which will be explained hereafter.

**[0035]** Toilet paper of the toilet roll 198 follows a path via the guiding rod 120 over the wettable roll 111. When toilet paper is taken from the holder 100, the wettable roll 111 acts as a guiding roll. The wettable roll 111 carries a minimal amount of water because it gets wet and releases water to the toilet paper that is guided over the wettable roll 111.

**[0036]** In case a user does not wish moistened toilet paper but prefers dry toilet paper, the user can let the toilet paper follow an alternative path (in Fig. 1a shown with a broken line).

**[0037]** In the embodiment illustrated here the housing 101 is provided with a tear-off edge 150, for instance a serrated edge or sharp edge, in order to be able to easily separate individual sheets of toilet paper.

**[0038]** Fig. 1b shows that the sidewalls 160 are provided with organs 161, here in the form of bent wire springs 161, for rotatably holding the toilet roll 198.

**[0039]** Fig. 2 shows an alternative embodiment of a holder 100 for supplying toilet paper. The liquid reservoir 110 contains two pairs of recesses 115', 115". Above the liquid reservoir 110 a guiding plate 220 is provided which has a window 221. In case the cams 112 of the wettable roll 111 are received by the second pair of recesses 115" (which position of the wettable roll is designated as the second location), part of the wettable roll 111 protrudes through the window 221. In that case the holder 100 will be able to supply moistened toilet paper.

**[0040]** When the wettable roll 111 is in the first pair of recesses 115' (designated as the first location), the wettable roll 111 does not protrude through the window 221. In that case the holder 100 will be able to deliver non-moistened toilet paper.

**[0041]** For moving the wettable roll 111 from the first location to the second and vice versa the sidewalls 160 will be provided with openings or the sidewalls 160 may even be completely absent.

**[0042]** Fig. 3a and Fig. 3b show part of a device 100 according to the invention for supplying kitchen paper 398 of a kitchen roll (not shown).

**[0043]** With the embodiment illustrated here the guiding plate 220 is hingedly attached to the liquid reservoir 110 by means of a hinge 301.

**[0044]** Instead, the guiding plate 220 could also have

been attached hingedly to the housing 101.

**[0045]** In a first position (Fig. 3a) the wettable roll 111 does not protrude through the window 221 of the guiding plate 220 and the device 100 can deliver non-moistened kitchen paper 398.

**[0046]** In a second position (Fig. 3b) the wettable roll 111 does protrude through the window 221 of the guiding plate 220 and the device 100 can deliver moistened kitchen paper 398.

**[0047]** Fig. 4 shows a hollow wettable roll 111. By using a hollow wettable roll 111 the amount of water in the liquid reservoir 110 can be increased and more time will pass before it has to be refilled. The hollow wettable roll 111 may also permit to be used for filling the liquid reservoir 110. In that case only one end of the liquid reservoir 110 will be provided with a fill opening 401. This fill opening is preferably situated near the circumferencial wall of the wettable roll 111 whereby the water can run from the wettable roll 111 into the liquid reservoir 110.

**[0048]** Fig. 5a and Fig. 5b show an alternative embodiment of a device 100 according to the invention in respectively a first position wherein the absorbing paper is not moistened (Fig. 5a) and a second position wherein the absorbing paper is moistened (Fig. 5b). To this end the housing 101 has a first hole 531 at the supply side and a second hole 532 below the first hole 531. The guiding plate 220 has a tab 570. This can be brought into one of the holes 531, 532, whereby the guiding plate 220, depending on the choice of a user, can be brought into a first high position (Fig. 5a) and a second low position (Fig. 5b). In the embodiment illustrated here the guiding plate 220 rests on an elevated longitudinal wall of the liquid reservoir 110 at an end opposite to the tab 570. Instead, the housing 101 may be provided with cams or holes in the sidewalls thereof which cooperate with the guiding plate 220.

**[0049]** A variety of variants is conceivable. Thus, the tab 570 may also be inserted through the holes 531, 532 from the inside of the holder 100. Thereby in the second position the tab 570 may rest on the bottom of the holder whereby the second hole 532 becomes superfluous. In the first position of the guiding plate 220 the tab 570 may also rest on an edge of the liquid reservoir 110. Hereby the use of one or more holes 531, 532 can be abstained from.

**[0050]** A device 100 according to the invention may comprise a pressing roll 571 which enhances the contact between the absorbing paper and the wettable roll 111. Therewith the use of a guiding rod 120 can be abstained from. For the embodiment discussed here, the pressing roll 571 stays in place by the sidewalls of the housing 101 and the downward sloping characteristic of the guiding plate 220 towards the front side of the holder 100. The pressing roll 571 is preferably longer than the length of the window 221.

**[0051]** Fig. 6 shows a liquid reservoir 110 suitable for a device 100 according to the invention. The shown liquid reservoir 110 has a very large capacity. When liquid is

abstracted for moistening absorbing paper, air will get into the closed part 620 of the liquid reservoir 110.

**[0052]** By means of a broken line the location is indicated where the guiding rod 120 can be situated when the liquid reservoir 110 is situated in a device 100.

**[0053]** The invention can be varied within the scope of the accompanying claims. For example, a device according to the invention does not require organs for rotatably holding a roll. In such a case such a device may be provided below a conventional device for supplying absorbing paper wherein the absorbing paper is guided through the device according to the invention. In such a case the device will contain a pressing roll in order to guarantee that there is sufficient contact between a wetted wettable roll and absorbing paper.

**[0054]** Fig. 7 shows a cross section through a housing 101 of a holder 100 wherein the liquid reservoir 110 is not shown.

**[0055]** The housing 101 comprises a back wall 703 provided with screw holes 705 for hanging up the holder 100. The housing 101 further comprises a base part 704 connected with the back wall 703 onto which the liquid reservoir 110 can be placed.

**[0056]** For hanging up a toilet roll (not shown) the housing 101 comprises an arm 706 connected with the back wall 703, provided with a cylinder shaped organ 707 that is unilaterally connected with the arm 706, which protrudes into the toilet roll when this is applied and around which the toilet roll can rotate.

**[0057]** The guiding organ 120 is hung up unilaterally in a similar way at a short arm 716, and is provided with the tear-off edge 150.

**[0058]** Because of the unilateral suspension of the cylinder shaped organ 707 and the guiding organ 120 a toilet roll can be provided very easily and the paper can be fed easily between the guiding organ 120 and the back wall 703.

**[0059]** Fig. 8 shows a perspective view on a liquid reservoir 110 without a lid which acts as a guiding plate 220. Recesses 820 can be seen at the interior of opposite sidewalls 821 for receiving the wettable roll 111 (not shown). At the outside of the opposite sidewalls 821 cams 822 are provided for providing the guiding plate 220 pivotable on the liquid reservoir 110.

**[0060]** At the front wall 823 of the liquid reservoir 110 a tab 841 is provided whose function will be explained in relation to the lid shown separately in Fig. 9 (guiding plate 220).

**[0061]** Fig. 9 shows a perspective view on the guiding plate 220 of the liquid reservoir 110 of Fig. 8, of which the upper side acts as a guide for absorbing paper to be passed over it. The guiding plate 220 has two flange parts 931 which extend downwardly transverse to the upper side and are provided with holes 932 for receiving the cams 822 of the liquid reservoir 110. This makes it possible to let the guiding plate 220 pivot about the cams 822. The guiding plate 220 can be attached to the liquid reservoir in two positions, for delivering either moistened

or dry toilet paper as desired. To this end with the embodiment illustrated here the guiding plate 220 has a second tab 942 which rests in a first (high) position of the guiding plate 220 and thus of the guiding plate 220 on the first tab 841 and in a second (low) position is situated under the first tab 841.

**[0062]** With the embodiment illustrated here there is a third tab 943, and in the first (high) position the first tab 841 is clasped between the second tab 942 and the third tab 943.

**[0063]** With the embodiment illustrated in Fig. 8 and Fig. 9 the tabs 841, 942, 943 extend across the full width of respectively the liquid reservoir 110 and the guiding plate 220. This is not required as long as the tabs can co-operate for keeping the guiding plate 220 in a desired position. The tabs may also be designated as cams.

**[0064]** Fig. 10a and Fig. 10b show an alternative device 100 according to the invention, which just like the device of Fig. 5 can be suspended under a toilet roll holder. The device 100 comprises a back wall 703 and a guiding organ 120 between which absorbing toilet paper will be passed. With one end thereof the guiding organ 120 is connected with the back wall 703 via a sidewall 1020. The device 100 further comprises a liquid reservoir 110 provided with a wettable roll 111. In a first position (Fig. 10a) this wettable roll 111 can be covered with a rotatable cover 1011, which is mounted rotatably and can be brought to a second position (Fig. 10b) for exposing the wettable roll 111, whereby depending on the position of the lid which acts as a guiding plate 220 moistened absorbing toilet paper can be delivered. For placing it in the first position the liquid reservoir 110 is provided with a groove 1021.

## Claims

1. Device (100) for supplying absorbing paper of a roll (198), which device (100) comprises

- a liquid reservoir (110), and
- a wettable roll (111) which is mounted rotatably and is at least partly received in the liquid reservoir (110),

and the absorbing paper during the unwinding of the roll (198) can be led into contact with the wettable roll (111) wherein the wettable roll (111) rotates and can supply liquid from the liquid reservoir (110) to the absorbing paper, wherein the device (100) is arranged for supplying i) non-moistened absorbing paper, and ii) moistened absorbing paper as desired by the user, **characterized in that** the device (100) has a guiding plate (220) which provides a window (221), the guiding plate (220) acts as a lid of the liquid reservoir (110), and the guiding plate (220) can be in a first position and in a second position, wherein

- in the first position the wettable roll (111) does not protrude through the window (221) for permitting the supply of non-moistened absorbing paper, and
- in the second position the wettable roll (111) protrudes partly through the window (221) for permitting the supply of moistened absorbing paper.
2. The device (100) according to claim 1, wherein the lowest point of the wettable roll (111) is situated above the bottom of the liquid reservoir (110) and the absorbing paper can be led over the upper side of the wettable roll (111).
3. The device (100) according to claim 1 or 2, wherein the reservoir has a first tab (841); and the guiding plate (220) has a second tab (942); and the guiding plate (220) can be in a first position and in a second position, wherein
- the guiding plate (220) in the first position can rest with second tab (942) on the first tab (841) and the wettable roll (111) does not protrude through the window (221) for permitting the supply of non-moistened absorbing paper, and
- in the second position the second tab (942) is clicked over the first tab (841) and the wettable roll (111) protrudes partly through the window (221) for permitting the supply of moistened absorbing paper.
4. The device (100) according to any of the preceding claims, wherein the device (100) comprises a cover (1011) which is movable between a first position in which the guiding plate covers the wettable roll (111) for permitting the supply of non-moistened absorbing paper, and a second position in which the cover (1011) exposes the wettable roll (111) for permitting the supply of moistened absorbing paper.
5. The device (100) according to any of the preceding claims, wherein the device (100) is arranged for rotatably holding a roll (198) of the absorbing paper having a diameter of at least 9 cm.
6. The device (100) according to any of the preceding claims, wherein the device is arranged for non-freely rotatably holding a roll (198) of absorbing paper.
7. The device (100) according to any of the preceding claims, wherein the wettable roll (111) is hollow and is provided with an opening (401).
8. The device (100) according to any of the preceding claims, wherein the liquid reservoir (110) is a liquid reservoir (110) that can be detached from the device (100).
9. The device (100) according to any of the preceding claims, wherein the device (100) has a guiding organ (120) that is suitable for guiding the absorbing paper before the absorbing paper can be supplied via a first path through the device (100) not in contact with the wettable roll (111), and can be supplied moistened via a second path through the device (100) in contact with the wettable roll (111).
10. The device (100) according to claim 9, wherein the guiding organ (120) is provided with a tear-off edge (150).
11. The device (100) according to any of the preceding claims, wherein wettable roll (111) comprises a surface that is formed by closed cell-foam for moistening the paper that can be moistened.
12. The device (100) according to any of the preceding claims, wherein the guiding plate (220) has flange parts (931) which extend downwardly transverse to the upper side.

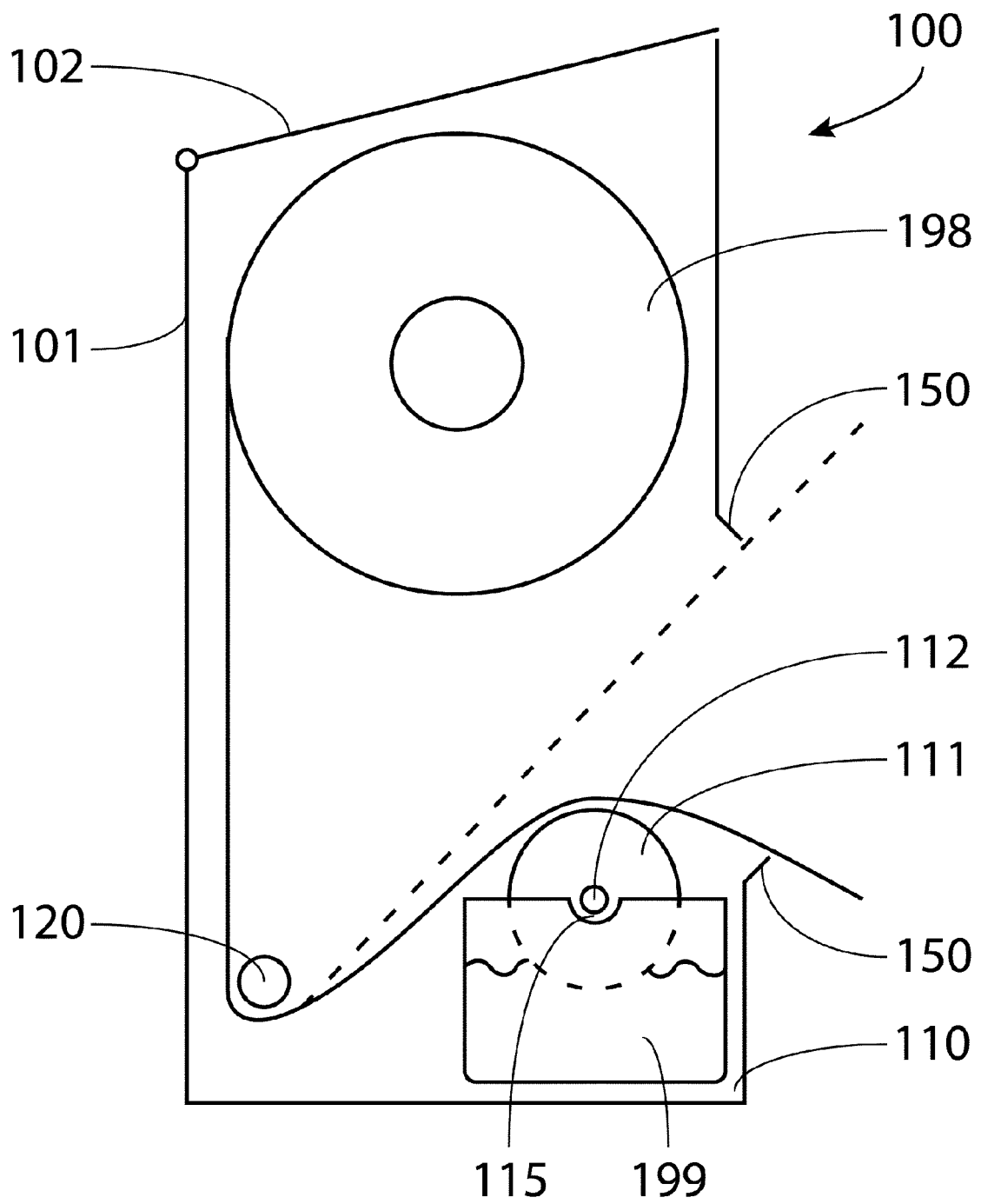

Fig. 1A

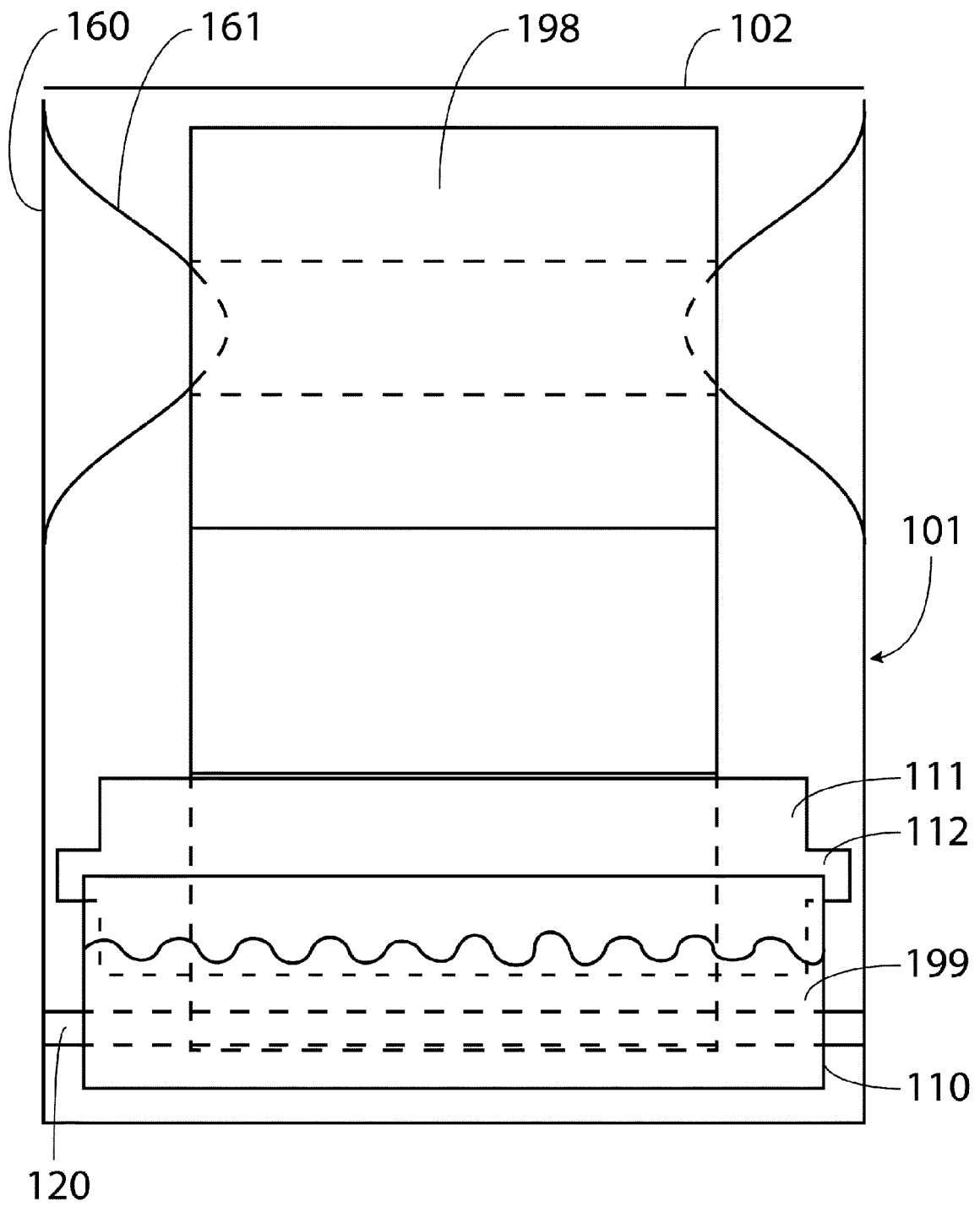

Fig. 1B

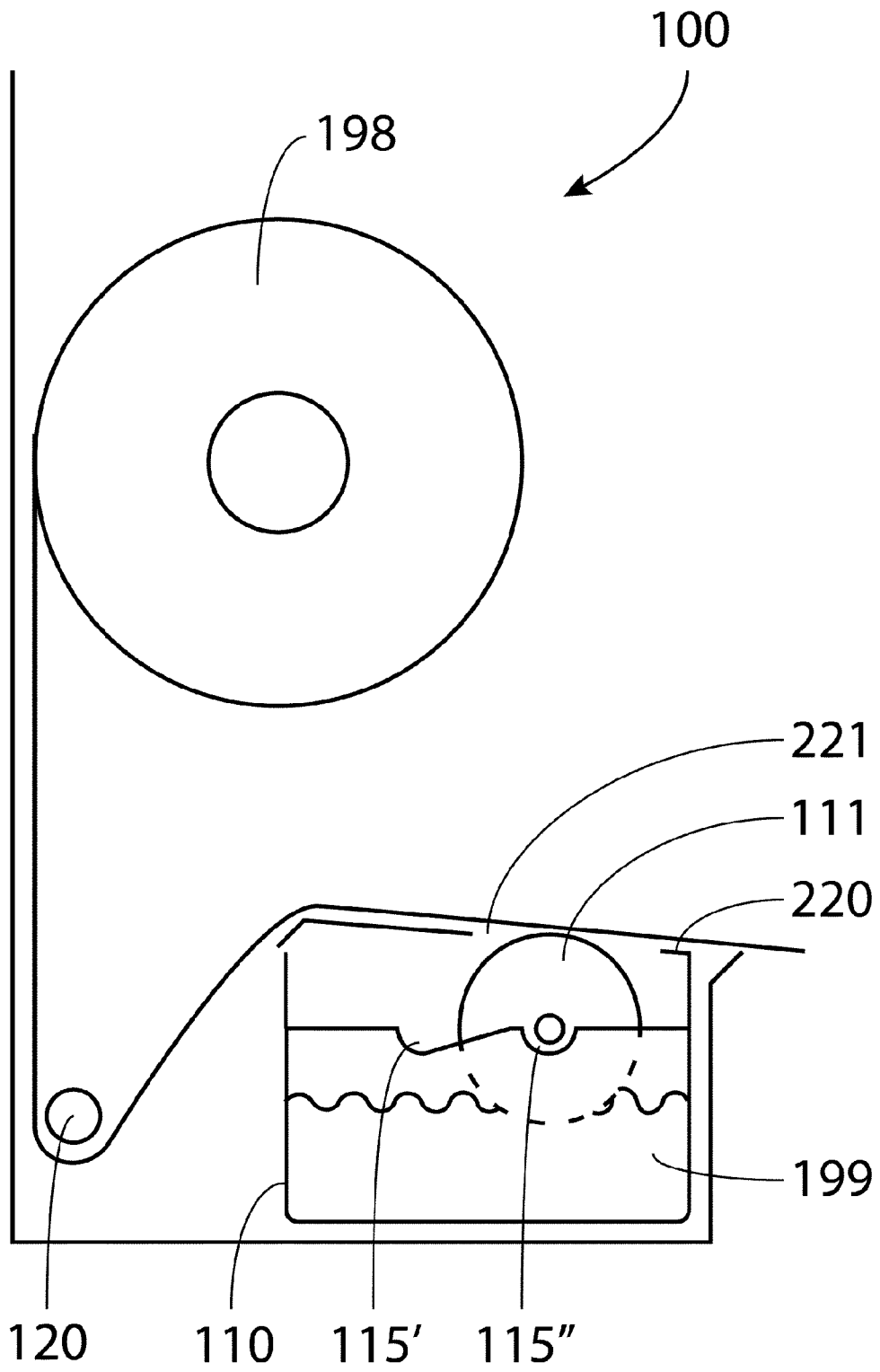

Fig. 2

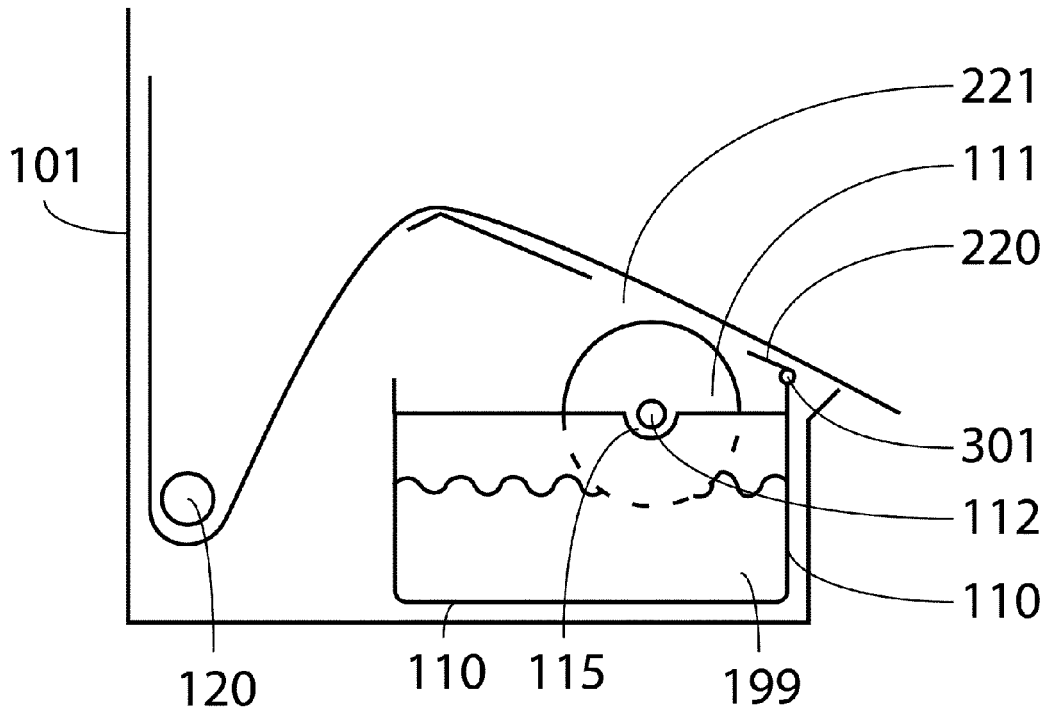

Fig. 3A

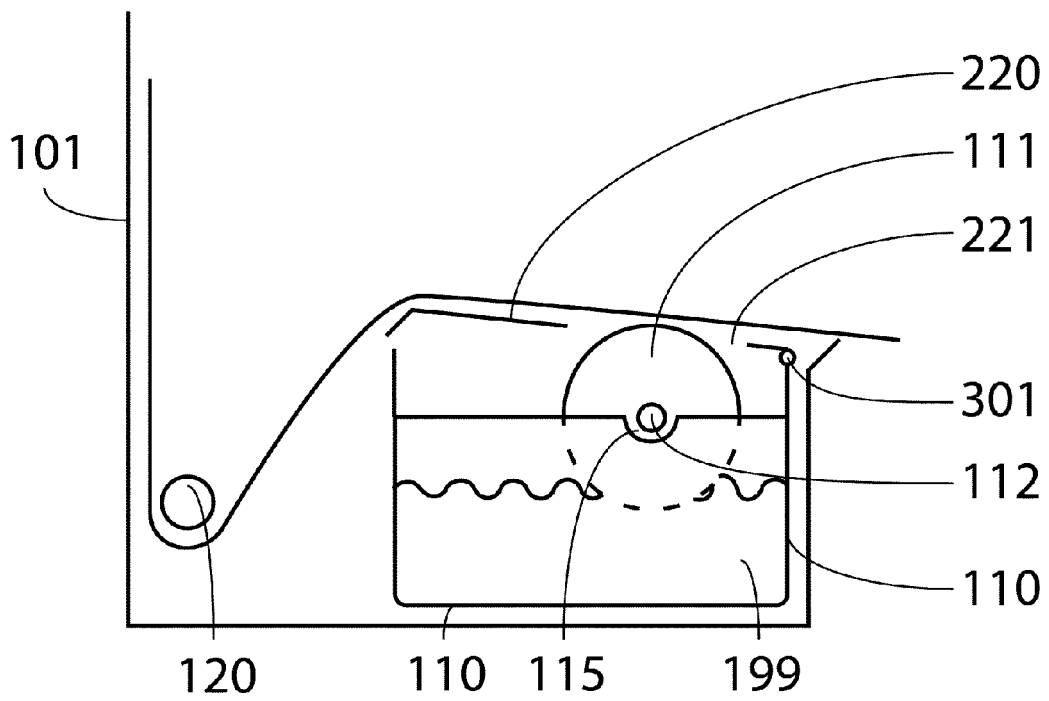

Fig. 3B

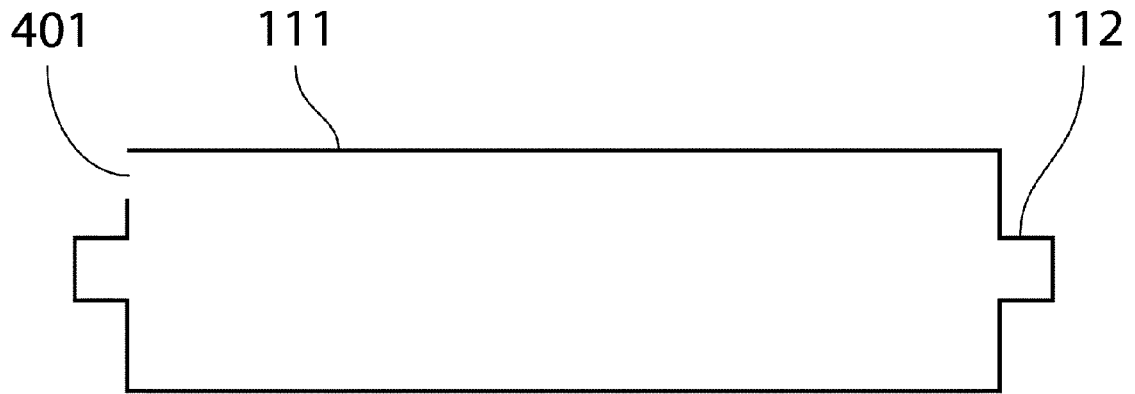

Fig. 4

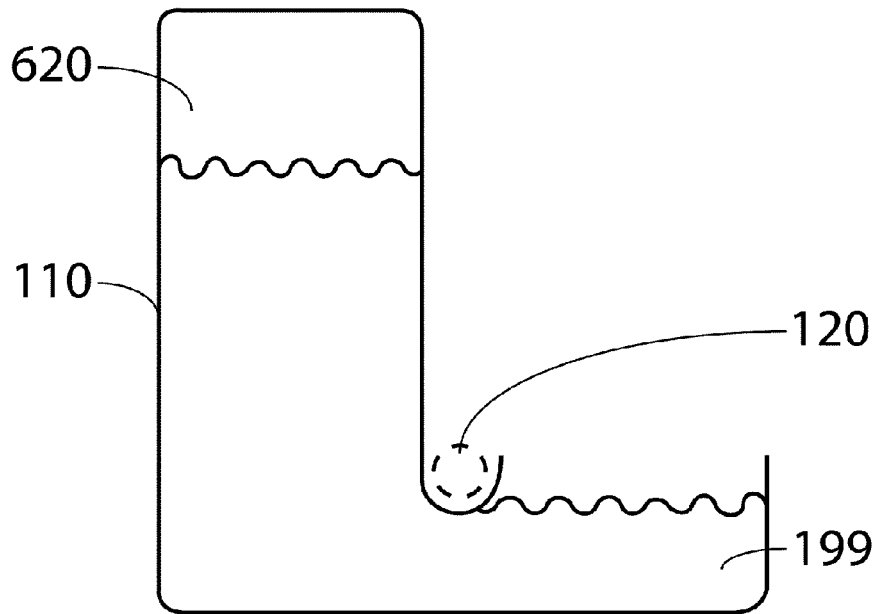

Fig. 6

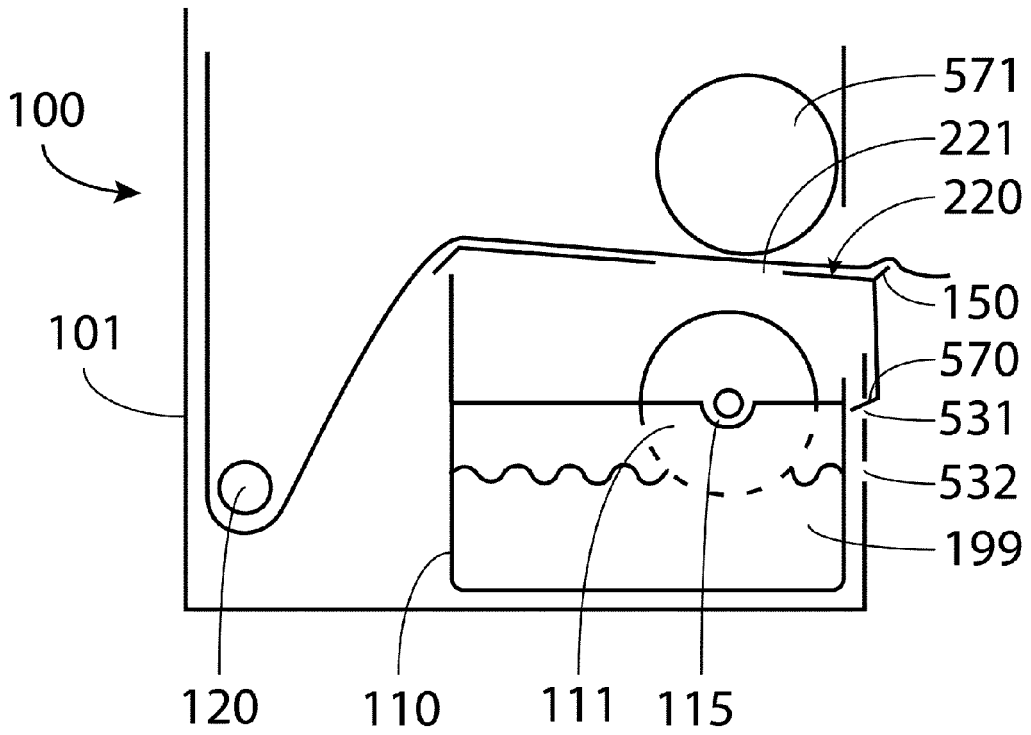

Fig. 5A

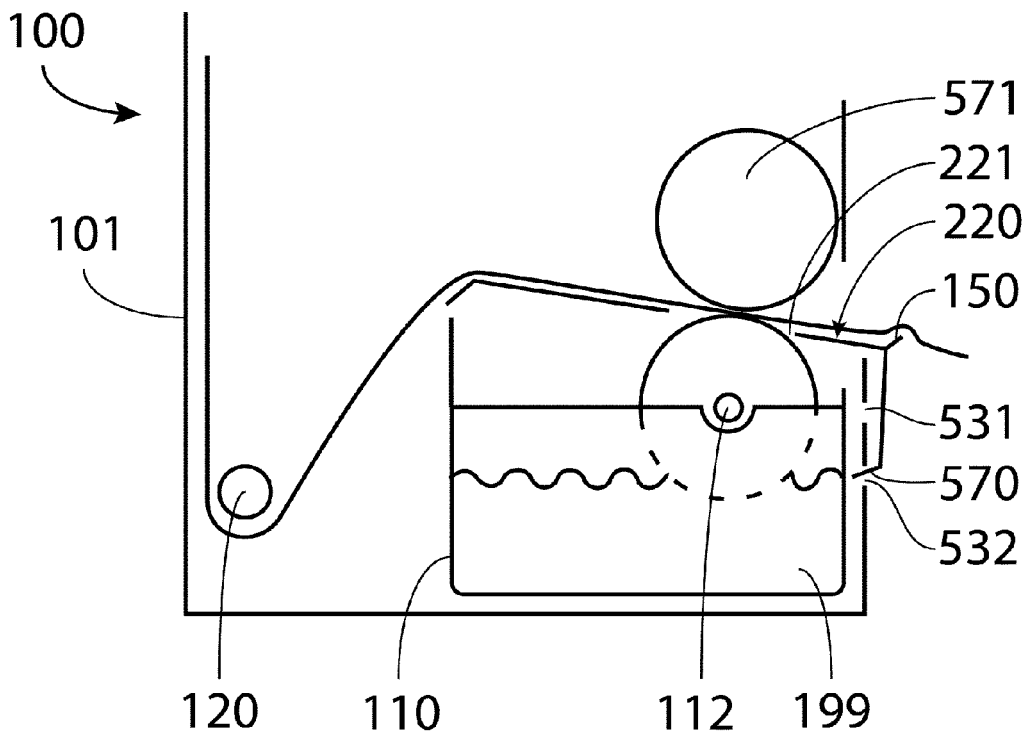

Fig. 5B

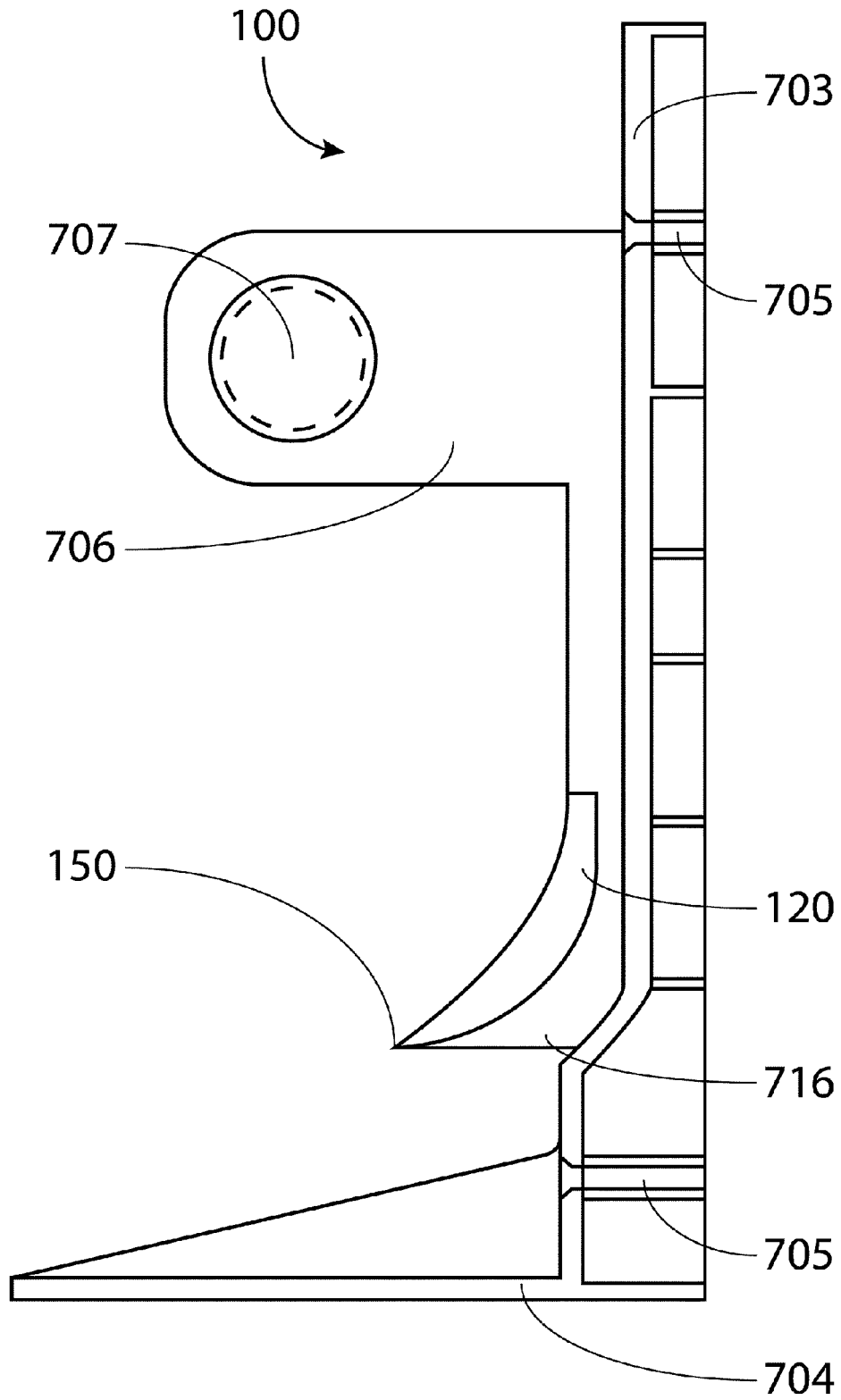

Fig. 7

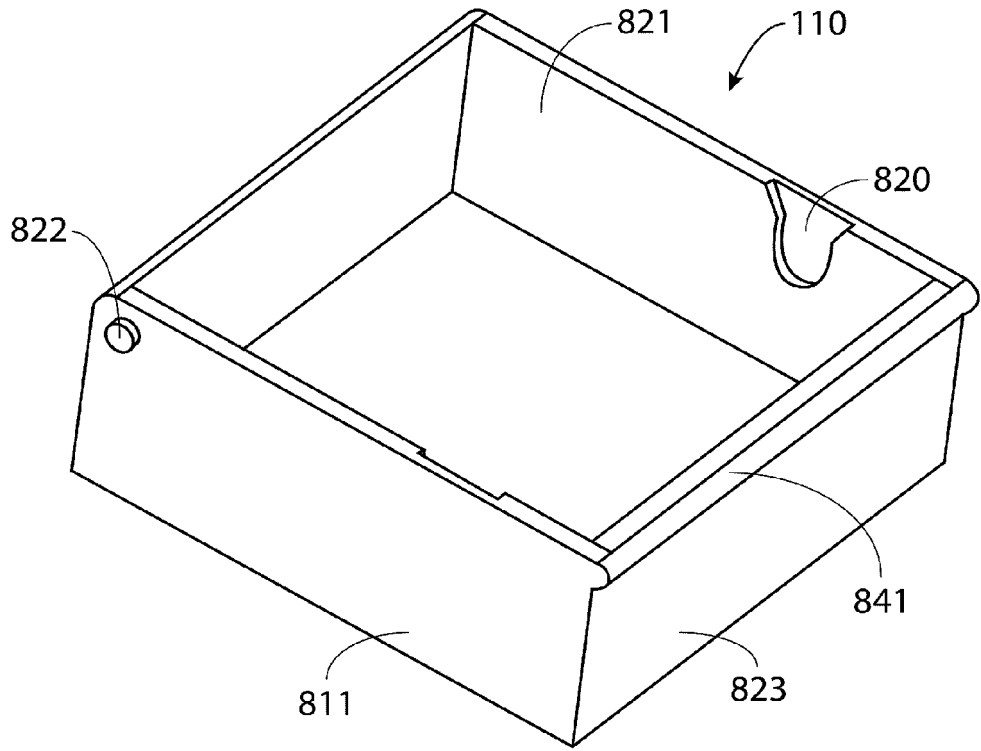

Fig. 8

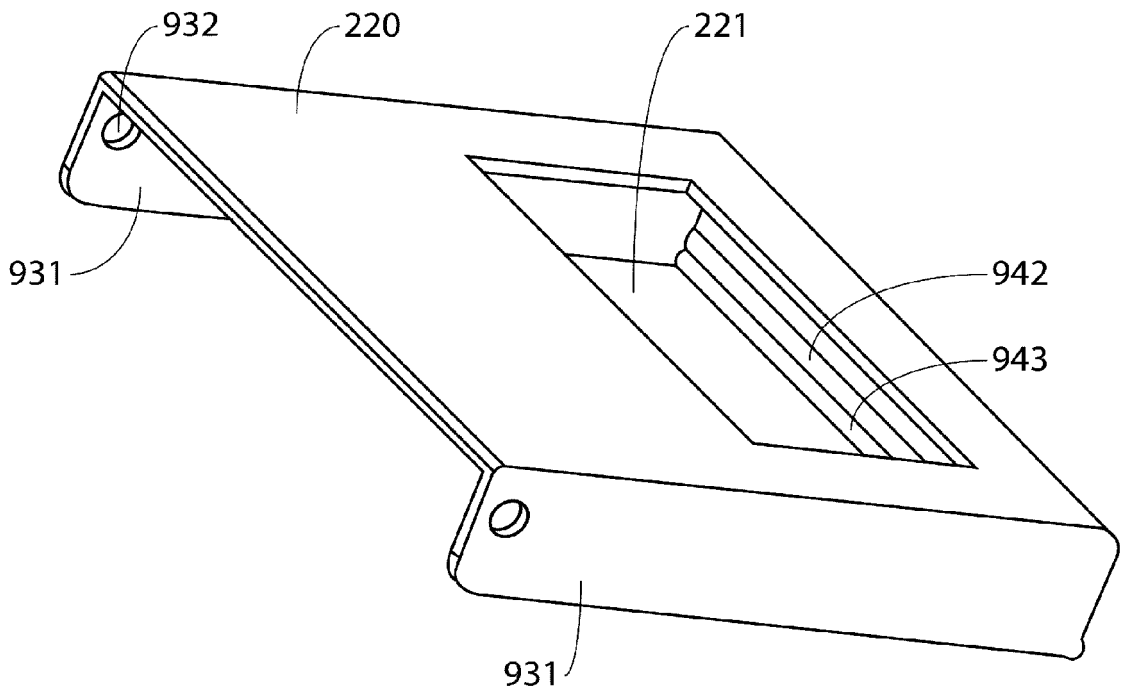

Fig. 9

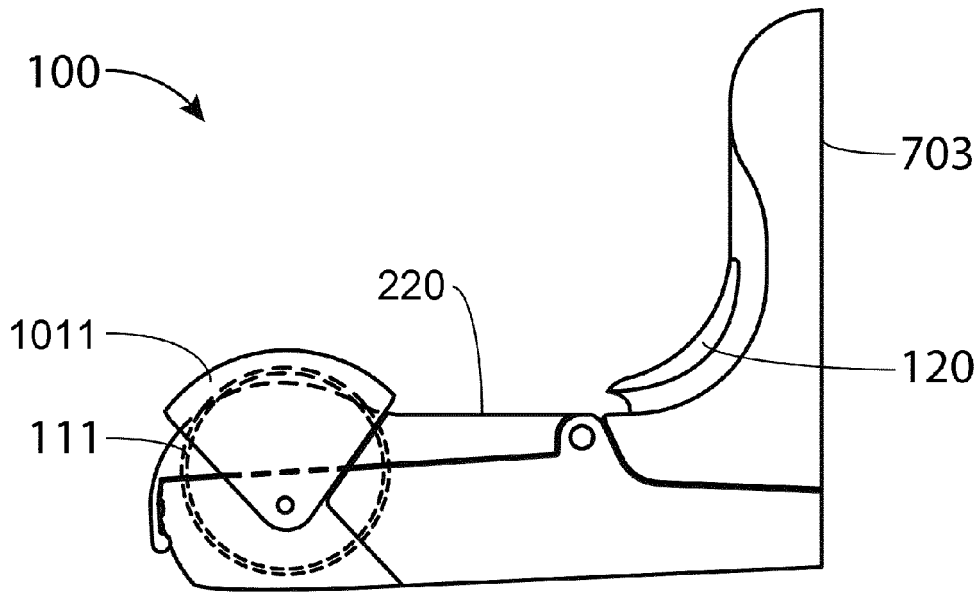

Fig. 10A

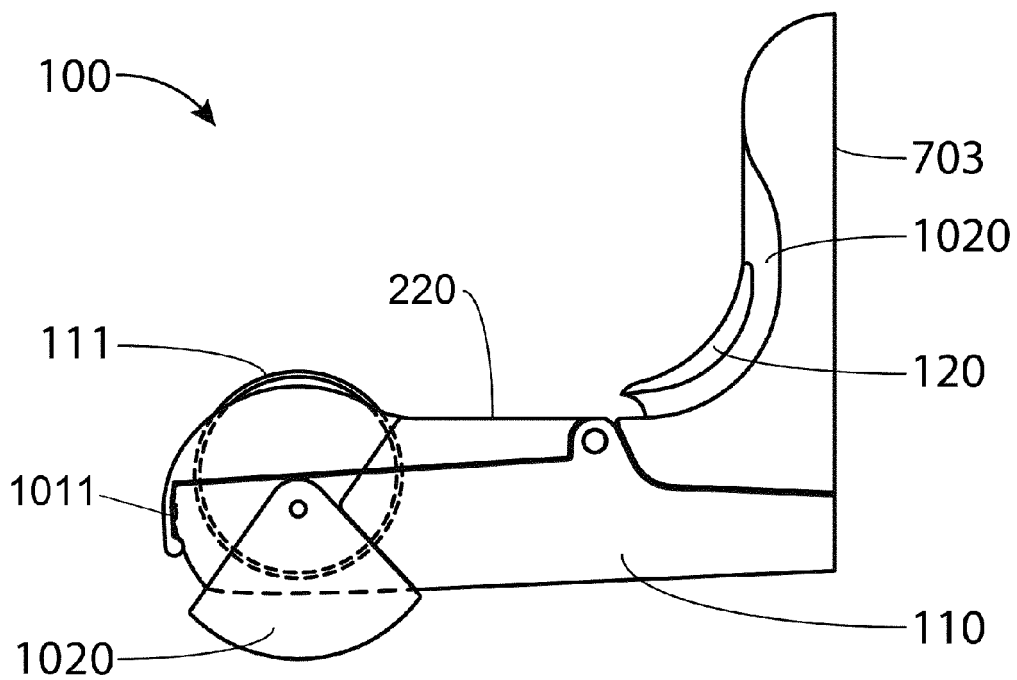

Fig. 10B

**REFERENCES CITED IN THE DESCRIPTION**

*This list of references cited by the applicant is for the reader's convenience only. It does not form part of the European patent document. Even though great care has been taken in compiling the references, errors or omissions cannot be excluded and the EPO disclaims all liability in this regard.*

**Patent documents cited in the description**

- WO 9208403 A [0002] [0005]