



- (51) International Patent Classification:  
B65G 47/22 (2006.01) B65G 17/12 (2006.01)  
B65G 13/00 (2006.01)
- (21) International Application Number:  
PCT/US2014/036946
- (22) International Filing Date:  
6 May 2014 (06.05.2014)
- (25) Filing Language: English
- (26) Publication Language: English
- (30) Priority Data:  
13/892,940 13 May 2013 (13.05.2013) US
- (71) Applicant: LAITRAM, L.L.C. [US/US]; Legal Department, 200 Laitram Lane, Harahan, Louisiana 70123 (US).
- (72) Inventor: FOURNEY, Matthew L.; 8714 Teresa Lane, Laurel, Maryland 20723 (US).
- (74) Agent: CRONVICH, James T.; Laitram, L.L.C., 200 Laitram Lane, Harahan, Louisiana 70123 (US).
- (81) Designated States (unless otherwise indicated, for every kind of national protection available): AE, AG, AL, AM, AO, AT, AU, AZ, BA, BB, BG, BH, BN, BR, BW, BY, BZ, CA, CH, CL, CN, CO, CR, CU, CZ, DE, DK, DM,

DO, DZ, EC, EE, EG, ES, FI, GB, GD, GE, GH, GM, GT, HN, HR, HU, ID, IL, IN, IR, IS, JP, KE, KG, KN, KP, KR, KZ, LA, LC, LK, LR, LS, LT, LU, LY, MA, MD, ME, MG, MK, MN, MW, MX, MY, MZ, NA, NG, NI, NO, NZ, OM, PA, PE, PG, PH, PL, PT, QA, RO, RS, RU, RW, SA, SC, SD, SE, SG, SK, SL, SM, ST, SV, SY, TH, TJ, TM, TN, TR, TT, TZ, UA, UG, US, UZ, VC, VN, ZA, ZM, ZW.

- (84) Designated States (unless otherwise indicated, for every kind of regional protection available): ARIPO (BW, GH, GM, KE, LR, LS, MW, MZ, NA, RW, SD, SL, SZ, TZ, UG, ZM, ZW), Eurasian (AM, AZ, BY, KG, KZ, RU, TJ, TM), European (AL, AT, BE, BG, CH, CY, CZ, DE, DK, EE, ES, FI, FR, GB, GR, HR, HU, IE, IS, IT, LT, LU, LV, MC, MK, MT, NL, NO, PL, PT, RO, RS, SE, SI, SK, SM, TR), OAPI (BF, BJ, CF, CG, CI, CM, GA, GN, GQ, GW, KM, ML, MR, NE, SN, TD, TG).

**Declarations under Rule 4.17:**

- as to applicant's entitlement to apply for and be granted a patent (Rule 4.17(ii))
- as to the applicant's entitlement to claim the priority of the earlier application (Rule 4.17(iii))

[Continued on next page]

(54) Title: METHOD AND CONVEYOR FOR REGISTERING ARTICLES ON A CONVEYOR BELT

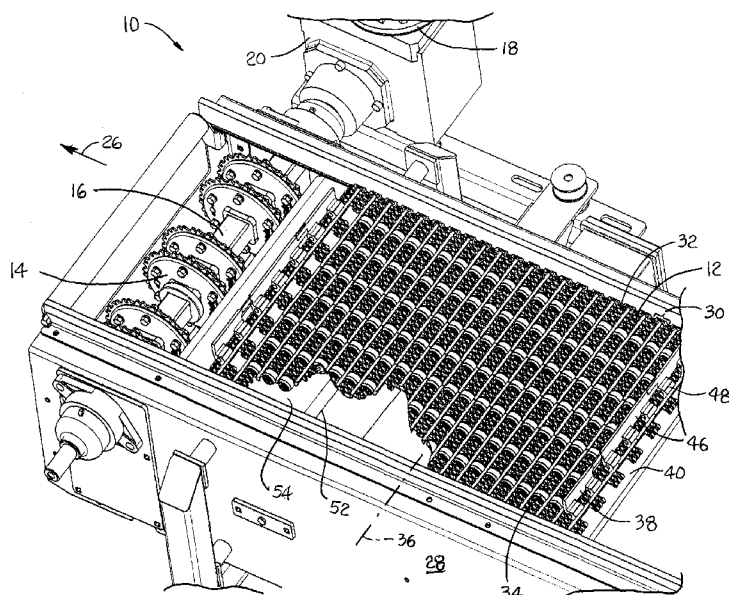

FIG. 1

(57) Abstract: Method and a conveyor for registering articles on a conveyor belt. The conveyor includes a registration belt having retractable flights regularly spaced along the length of the belt and article-propelling rollers between consecutive flights. The flights are raised in an upstream portion of the conveyor, and the rollers rotated to propel articles forward against the raised flights. In a downstream portion of the conveyor, a flat-top belt under the conveyor belt runs faster than the conveyor belt and causes the flights to lower and the rollers behind the lowering flights to rotate in reverse to urge the articles away from interfering with the lowering flights.



**Published:**

— with international search report (Art. 21(3))

— before the expiration of the time limit for amending the claims and to be republished in the event of receipt of amendments (Rule 48.2(h))

**METHOD AND CONVEYOR FOR REGISTERING ARTICLES ON A CONVEYOR BELT****BACKGROUND**

The invention relates to power-driven conveyors generally and in particular to belt conveyors with article-propelling rollers and retractable flights.

5 Registration belts are used to accurately space conveyed articles. One example of a registration belt has retractable flights spaced at regular intervals and in-line rollers between consecutive flights. A bearing surface under the belt raises the flights to a blocking position by cam action. As the belt passes over the bearing surface, the belt rollers rotate on the bearing surface and propel conveyed articles forward in the direction of belt travel into  
10 registration against a raised flight. At the end of the belt's carryway run, the registered articles' positioning against the flight can interfere with the flight's closing.

**SUMMARY**

A method embodying features of the invention for registering articles on a conveyor belt comprises: (a) conveying articles atop rollers in a conveyor belt advancing downstream  
15 in a direction of belt travel on an upper run; (b) propelling the articles forward relative to the conveyor belt by rotating the rollers in a forward direction in the direction of belt travel in an upstream portion of the upper run; (c) raising flights disposed at spaced apart positions along the length of the conveyor belt to a raised position in the upstream portion of the upper run; (d) lowering the flights in a downstream portion of the upper run; and (e)  
20 reversing the direction of rotation of the rollers in the downstream portion of the upper run to urge articles away from the lowering flights to allow the flights to lower without being obstructed by the conveyed articles.

In another aspect of the invention, a conveyor embodying features of the invention comprises a conveyor belt advancing at a certain speed in the direction of belt travel  
25 downstream along an upper run. The conveyor belt includes flights disposed at spaced apart positions along the length of the belt. The flights have lower contact elements that extend below the conveyor belt and upper portions that are retractable from a raised position blocking conveyed articles atop the conveyor belt to a lowered position allowing conveyed articles to pass over. Rollers extend through the thickness of the conveyor belt  
30 between the spaced apart locations of the flights. An immobile bearing surface lies under the conveyor belt along an upstream portion of the upper run. Contact between the immobile

bearing surface and the contact elements of the flights raises the upper portions of the flights to the raised position. Contact between the immobile bearing surface and the rollers causes the rollers to rotate in a forward direction pushing articles atop the roller downstream in a direction of belt travel. A flat-top belt is disposed under the top run downstream of the  
5 immobile bearing surface. The belt has an outer surface that contacts the contact elements and the bottoms of the rollers. The flat-top belt advances in the direction of belt travel of the conveyor belt at a speed greater than the speed of the conveyor belt. Contact between the outer surface of the flat-top belt and the contact elements causes the flights to lower. Contact  
10 between the outer surface of the flat-top belt and the rollers changes the direction of rotation of the rollers to a reverse direction opposite to the direction of belt travel. The rollers, rotating in reverse, urge articles away from the lowering downstream flights. In this way, the flights can lower to their lowered position without being obstructed by the conveyed articles.

#### BRIEF DESCRIPTION OF THE DRAWINGS

15 FIG. 1 is an isometric view, partly cut away, of a portion of a registration conveyor embodying features of the invention; and

FIG. 2 is a side elevation schematic of the conveyor of FIG. 1.

#### DETAILED DESCRIPTION

A registration conveyor embodying features of the invention is shown in FIGS. 1 and  
20 2. The conveyor 10 includes a registration conveyor belt 12 whose inner side is engaged and driven by a drive system that includes, in this example, a set of drive sprockets 14 mounted on a drive shaft 16 and driven by a motor 18 through a gear box 20. The endless conveyor belt 12 is trained between the drive sprockets 14 and idle sprockets 15 at opposite ends of the conveyor. (The conveyor belt 12 is shown cut away in FIG. 1 to reveal underlying  
25 components.) The motor 18 drives the conveyor belt 12 along an upper run 22 from an upstream end 24 to a downstream end 25 in a direction of belt travel 26. The drive sprockets 14 serve as reversing elements that reverse the direction of the conveyor belt 12 from the upper run 22 to a lower return run 23. The conveyor belt and all its drive components are mounted in a conveyor frame 28.

30 The conveyor belt 12 is shown as a modular plastic conveyor belt constructed of a series of rows 30 of one or more belt modules linked at hinge joints 32 by hinge rods. Rollers

34 are mounted on the hinge rods at the hinge joints 32 to rotate on axes 36 perpendicular to the direction of belt travel 26. Cam-actuated retractable flights 38 are also mounted on the hinge rods at regular spaced apart positions along the length of the conveyor belt 12. But it would be possible for the flights and rollers to have dedicated axles or rods that provide  
5 pivot axes 36 perpendicular to the direction of belt travel 26. The rollers 34 are arranged in rows across the width of the belt and in lanes, or columns, along the length of the belt between consecutive flight positions. One example of such a conveyor belt is the INTRALOX® Series 900 Registration belt manufactured and sold by Intralox, L.L.C. of Harahan, Louisiana, U.S.A.

10 Supporting the registration conveyor belt in an upstream portion of the conveyor 10 is a stationary, or immobile, bearing surface 40 mounted in the frame 28. Although shown as a flat plate or pan in the drawings, the bearing surface could instead be realized as longitudinal strips aligned with the columns of rollers 34. The bearing surface 40 lies under the upper run 22 of the conveyor belt 12. The belt's rollers 34 ride on the immobile bearing  
15 surface 40 as the belt 12 advances in the direction of belt travel 26. The engagement of the rollers 34 with the bearing surface 40 causes the rollers to rotate in the direction of arrows 42, which propel articles 44 forward against a raised flight 38R.

The flights 38 have an upper portion 46 connected to a lower contact elements 48, which can be, for example, a cam follower having a cam surface or a roller having a rolling  
20 surface, pivotally attached to the conveyor belt at, for example, the hinge rod. In this example, the contact element 48 is illustrated as a cam follower that extends below the bottom of the conveyor belt 12. Contact between the immobile bearing surface 40 and the cam followers 48 along the upper run 22 pivots the flights 38 to lift them to their raised positions, as indicated by the raised flight 38R. Thus, the contact elements present contact  
25 surfaces that receive a force by contact with the bearing surface. The force acting against the contact surfaces of the contact elements causes the flights to be lifted to their raised positions by lever action in the case of cam-follower contact elements, by rotational action in the case of roller contact elements, or otherwise. The rear faces 50 of the raised flights mark registration positions on the conveyor belt 12. The forward-rotating rollers in the upstream  
30 portion of the upper run 22 propel the articles 44 forward into registration against a leading raised flight 38R.

A short length of an endless flat-top belt 52 is mounted in the conveyor frame 28 in a downstream portion of the conveyor 10. The flat-top belt 52 has a flat outer surface 54, which could be a high-friction surface. The outer surface 54 of the flat-top belt's upper run provides a mobile bearing surface that contacts the contact elements 48 and the bottoms of the belt rollers 34. The flat-top belt 52 is driven in the direction of belt travel 26 of the conveyor belt 12, as indicated by arrow 56, but at a greater speed. A drive pulley or sprocket 60 may be driven by a dedicated motor or coupled to the main drive motor 18 by a jack shaft or the like to drive the flat-top belt. Because the speed of the flat-top belt 52 in the direction of belt travel 26 exceeds that of the conveyor belt 12, the flights 38L start to lower by pivoting counterclockwise in FIG. 2 as indicated by arrow 57, and the belt rollers 34 reverse directions as indicated by arrows 58. The reverse rotation 58 of the belt rollers 34 pushes against the article 44' rearward relative to the conveyor belt 12 opposite to the direction of belt travel 26 to urge the article away from the lowering flight by either decelerating an article still moving toward the flight or pushing an article registered against the flight rearward out of the path of the lowering flight. In that way, the article 44' avoids obstructing the lowering of the flight 38L to its completely lowered position, i.e., with its upper portion 46 lying flat on the outer surface of the conveyor belt 12. The linear extent of the flat-top belt 52 in the direction of belt travel is relatively short so that the retreat of the articles from the registration position at the flights 38 is small. The linear extent of the immobile bearing surface 40 in the direction of belt travel can be greater than that of the flat-top belt 52.

In most instances, the flat-top belt 52 is positioned under the upper run 22 of the conveyor belt 12 close to the drive sprockets 14. In fact, the smaller drive pulleys or sprockets 60 of the flat-top belt 52 could be positioned to have some vertical overlap with the conveyor belt's larger-diameter drive sprockets 14. With the short flat-top belt positioned close to the downstream end 25 of the upper run 22, the articles are positioned only slightly behind their registration positions, which gives the flights room to lower completely without interference. The fully retracted flights allow the articles to transfer off the downstream end 25 of the conveyor 10 across a small gap.

## WHAT IS CLAIMED IS:

1. A method for registering articles on a conveyor belt, comprising:

conveying articles atop rollers in a conveyor belt advancing downstream in a direction of belt travel along an upper run;

- 5 propelling the articles forward relative to the conveyor belt by rotating the rollers in a forward direction in the direction of belt travel in an upstream portion of the upper run;

raising flights disposed at spaced apart positions along the length of the conveyor belt to a raised position in the upstream portion of the upper run to stop the articles being propelled forward at the positions of the flights;

10

lowering the flights in a downstream portion of the upper run;

reversing the direction of rotation of the rollers in the downstream portion of the upper run to urge articles away from the lowering flights to allow the flights to lower without being obstructed by conveyed articles.

- 15 2. The method of claim 1 comprising:

contacting the bottoms of the rollers and the flights with a bearing surface under the upper run of the conveyor belt in the downstream portion;

advancing the bearing surface in the direction of belt travel at a speed greater than the speed of the conveyor belt in the direction of belt travel.

- 20 3. The method of claim 1 comprising:

contacting the bottoms of the rollers and the flights with an immobile bearing surface under the upper run of the conveyor belt in the upstream portion.

4. A conveyor comprising:

a conveyor belt advancing at a first speed in a direction of belt travel downstream along an upper run, the conveyor belt including:

25

a plurality of flights disposed at spaced apart positions along the length of the

conveyor belt, wherein the flights have lower contact elements extending below the conveyor belt and upper portions retractable from a raised position blocking conveyed articles atop the conveyor belt to a lowered position allowing conveyed

30

articles to pass over the flights; and

a plurality of rollers extending through the thickness of the conveyor belt between the spaced apart positions of the flights;

an immobile bearing surface lying under the conveyor belt along an upstream portion of the upper run, wherein contact between the immobile bearing surface and the contact elements of the flights raises the upper portions of the flights to the raised position and wherein contact between the immobile bearing surface and the rollers causes the rollers to rotate in a forward direction pushing articles atop the rollers along the conveyor belt downstream in the direction of belt travel;

a flat-top belt disposed under the top run of the conveyor belt downstream of the immobile bearing surface and having an outer surface contacting the contact elements and the bottoms of the rollers;

wherein the flat-top belt advances in the direction of belt travel of the conveyor belt at a second speed greater than the first speed so that the contact between the outer surface of the flat-top belt and the contact elements causes the flights to lower and the contact between the outer surface of the flat-top belt and the rollers changes the rotation of the rollers to a reverse direction opposite to the direction of belt travel to urge conveyed articles away from the lowering downstream flights to allow the flights to lower to their lowered position without being obstructed by conveyed articles.

5. A conveyor as in claim 4 wherein the flat-top belt extends a first distance in length in the direction of belt travel and the immobile bearing surface extends a second distance in the direction of belt travel, wherein the second distance is greater than the first distance.
6. A conveyor as in claim 4 further comprising a reversing element at a downstream end of the upper run engaging the conveyor belt and directing it from the upper run to a lower return run, wherein the flat-top belt overlies a portion of the reversing element.

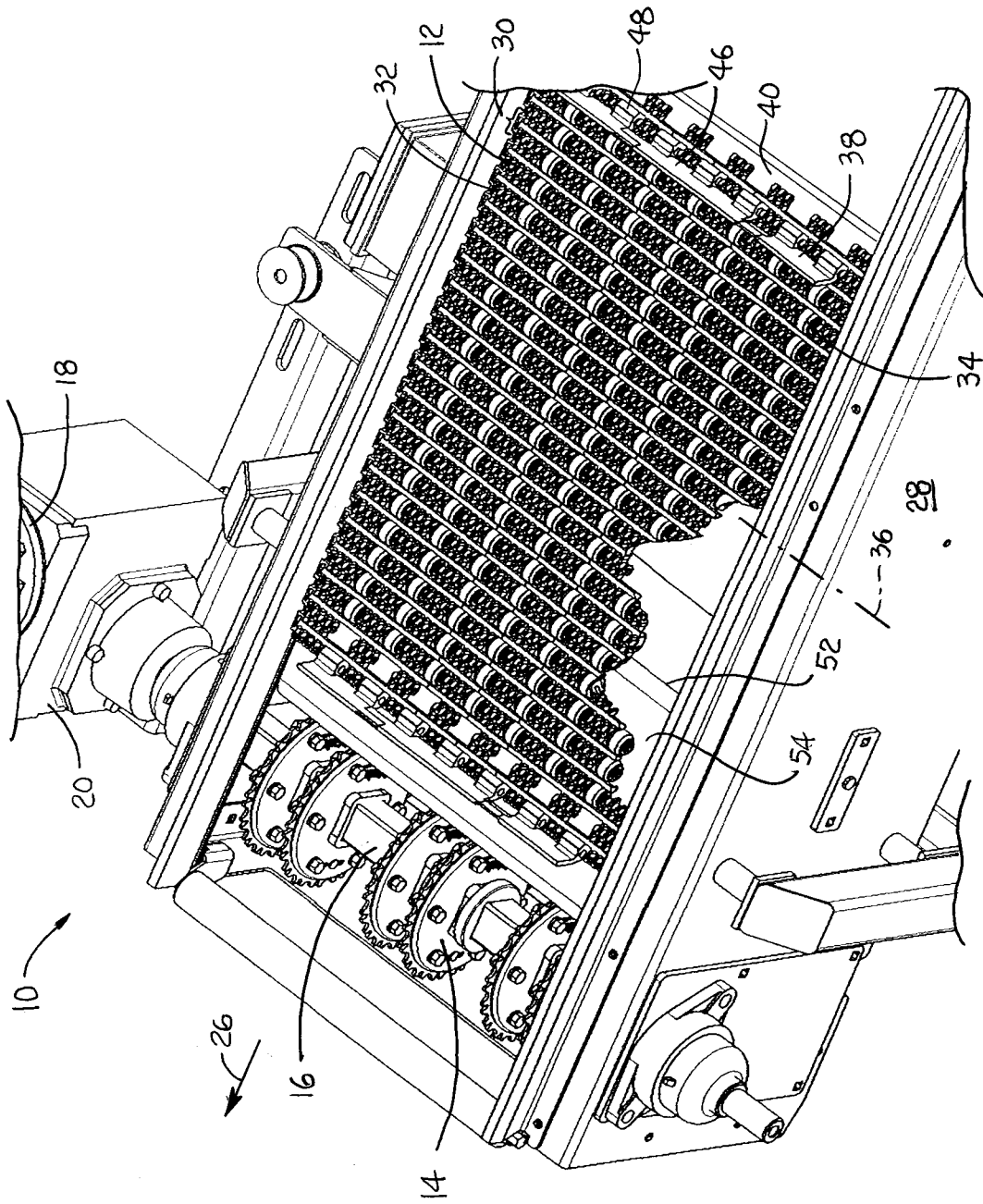

FIG. 1

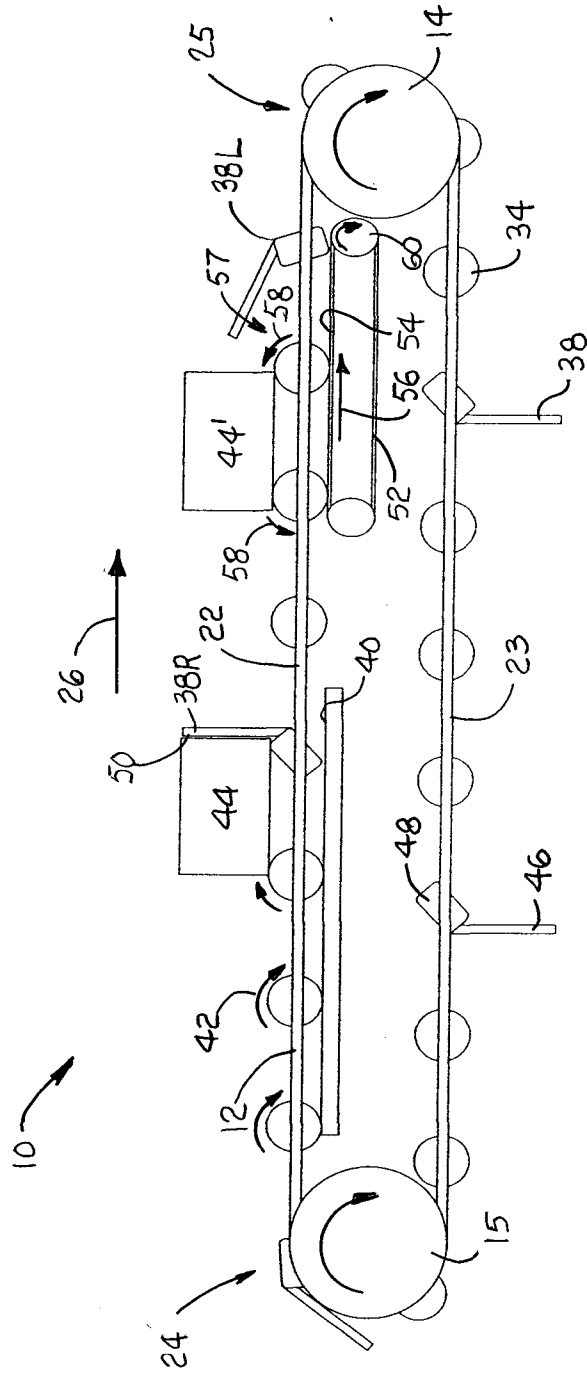

FIG. 2

## INTERNATIONAL SEARCH REPORT

International application No.  
**PCT/US2014/036946****A. CLASSIFICATION OF SUBJECT MATTER****B65G 47/22(2006.01)i, B65G 13/00(2006.01)i, B65G 17/12(2006.01)i**

According to International Patent Classification (IPC) or to both national classification and IPC

**B. FIELDS SEARCHED**

Minimum documentation searched (classification system followed by classification symbols)

B65G 47/22; B65G 47/29; B65G 17/24; B65G 47/24; B65G 47/34; B65G 47/28; B65G 13/10; B65G 47/68; B65G 13/00;  
B65G 17/12

Documentation searched other than minimum documentation to the extent that such documents are included in the fields searched

Korean utility models and applications for utility models  
Japanese utility models and applications for utility models

Electronic data base consulted during the international search (name of data base and, where practicable, search terms used)

eKOMPASS(KIPO internal) &amp; Keywords:articles, conveyor, belt, rollers, downstream, upstream, and flights

**C. DOCUMENTS CONSIDERED TO BE RELEVANT**

Category*	Citation of document, with indication, where appropriate, of the relevant passages	Relevant to claim No.
X	US 2012-0285799 A1 (FOURNEY, MATTHEW L.) 15 November 2012 See paragraphs [0002]-[0004],[0011]-[0012],[0015]-[0016]; claims 1,3,5-6,8; and figures 1,3,4.	1-6
A	US 2005-0072656 A1 (COSTANZO, MARK) 07 April 2005 See paragraphs [0001],[0005],[0016]-[0019],[0028]; and figure 1.	1-6
A	EP 2263953 A1 (LAI TRAM, LLC) 22 December 2010 See paragraphs [0001],[0008]-[0011]; and figure 1.	1-6
A	US 2007-0221471 A1 (FOURNEY et al.) 27 September 2007 See paragraphs [0001]-[0004],[0012]; and figure 1.	1-6
A	WO 2010-114754 A1 (LAI TRAM, L.L.C.) 07 October 2010 See page 1, lines 4-5; page 3, line 17 - page 4, line 3; and figure 2.	1-6

 Further documents are listed in the continuation of Box C. See patent family annex.

\* Special categories of cited documents:

"A" document defining the general state of the art which is not considered to be of particular relevance

"E" earlier application or patent but published on or after the international filing date

"L" document which may throw doubts on priority claim(s) or which is cited to establish the publication date of another citation or other special reason (as specified)

"O" document referring to an oral disclosure, use, exhibition or other means

"P" document published prior to the international filing date but later than the priority date claimed

"T" later document published after the international filing date or priority date and not in conflict with the application but cited to understand the principle or theory underlying the invention

"X" document of particular relevance; the claimed invention cannot be considered novel or cannot be considered to involve an inventive step when the document is taken alone

"Y" document of particular relevance; the claimed invention cannot be considered to involve an inventive step when the document is combined with one or more other such documents, such combination being obvious to a person skilled in the art

"&amp;" document member of the same patent family

Date of the actual completion of the international search

12 September 2014 (12.09.2014)

Date of mailing of the international search report

**12 September 2014 (12.09.2014)**

Name and mailing address of the ISA/KR

 International Application Division  
 Korean Intellectual Property Office  
 189 Cheongsu-ro, Seo-gu, Daejeon Metropolitan City, 302-701,  
 Republic of Korea

Facsimile No. +82-42-472-7140

Authorized officer

KIM, Jin Ho

Telephone No. +82-42-481-8699



## INTERNATIONAL SEARCH REPORT

Information on patent family members

International application No.

**PCT/US2014/036946**

Patent document cited in search report	Publication date	Patent family member(s)	Publication date
US 2012-0285799 A1	15/11/2012	AU 2011-205567 A1	05/07/2012
		AU 2011-205567 B2	21/11/2013
		CN 102695650 A	26/09/2012
		EP 2523858 A1	21/11/2012
		JP 2013-517192 A	16/05/2013
		KR 10-2013-0004901 A	14/01/2013
		RU 2012-127620 A	27/02/2014
		US 8544634 B2	01/10/2013
		WO 2011-087937 A1	21/07/2011
US 2005-0072656 A1	07/04/2005	US 6923309 B2	02/08/2005
EP 2263953 A1	22/12/2010	AT 513771 T	15/07/2011
		AU 2006-244530 A1	16/11/2006
		AU 2006-244530 B2	16/09/2010
		AU 2006-244531 A1	16/11/2006
		AU 2006-244531 B2	02/09/2010
		AU 2010-235880 A1	11/11/2010
		AU 2010-235880 B2	10/11/2011
		CA 2605539 A1	16/11/2006
		CA 2605539 C	15/11/2011
		CA 2609739 A1	16/11/2006
		CA 2609739 C	17/06/2014
		CN 101171189 A	30/04/2008
		CN 101171189 B	15/06/2011
		CN 101171190 A	30/04/2008
		CN 101171190 B	02/01/2013
		EP 1877329 A1	16/01/2008
		EP 1877329 B1	31/12/2008
		EP 1885632 A1	13/02/2008
		EP 1885632 B1	22/06/2011
		EP 2263954 A1	22/12/2010
		ES 2368444 T3	17/11/2011
		JP 05172660 B2	27/03/2013
		JP 2008-540291 A	20/11/2008
		JP 2008-540292 A	20/11/2008
		KR 10-1242430 B1	12/03/2013
		KR 10-1265538 B1	21/05/2013
		KR 10-2008-0022090 A	10/03/2008
		MX 2007-013806 A	05/02/2008
		PI 0611047 A2	10/08/2010
		US 2006-0249354 A1	09/11/2006
		US 2006-0249355 A1	09/11/2006
		US 2007-0284220 A1	13/12/2007
		US 2008-0289936 A1	27/11/2008
US 2010-0059334 A1	11/03/2010		
US 7249671 B2	31/07/2007		
US 7344018 B2	18/03/2008		
US 7537104 B2	26/05/2009		

**INTERNATIONAL SEARCH REPORT**

Information on patent family members

International application No.

**PCT/US2014/036946**

Patent document cited in search report	Publication date	Patent family member(s)	Publication date
US 2007-0221471 A1	27/09/2007	US 7617923 B2	17/11/2009
		US 7784601 B2	31/08/2010
		WO 2006-121749 A1	16/11/2006
		WO 2006-121750 A1	16/11/2006
		AU 2007-238418 A1	25/10/2007
		AU 2007-238418 B2	25/10/2012
		CN 101405205 A	08/04/2009
		CN 101405205 B	19/10/2011
		EP 1996491 A2	03/12/2008
		EP 1996491 B1	26/09/2012
		ES 2395858 T3	15/02/2013
		JP 05248473 B2	31/07/2013
		JP 2009-531249 A	03/09/2009
		KR 10-1335779 B1	02/12/2013
		KR 10-2009-0008257 A	21/01/2009
		MX 2008-012169 A	28/11/2008
		RU 2008-140069 A	27/04/2010
RU 2412885 C2	27/02/2011		
US 7284653 B2	23/10/2007		
WO 2007-121015 A2	25/10/2007		
WO 2007-121015 A3	03/01/2008		
WO 2010-114754 A1	07/10/2010	CN 102365217 A	29/02/2012
		CN 102365217 B	16/04/2014
		EP 2414261 A1	08/02/2012
		EP 2414261 B1	29/05/2013
		ES 2426139 T3	21/10/2013
		JP 2012-522703 A	27/09/2012
		KR 10-2012-0008517 A	30/01/2012
		MX 2011-010338 A	28/10/2011
		RU 2011-139639 A	10/05/2013
		US 2010-0252398 A1	07/10/2010
		US 7861849 B2	04/01/2011