



US 20080083861A1

(19) **United States**

(12) **Patent Application Publication**
Conroy et al.

(10) **Pub. No.: US 2008/0083861 A1**

(43) **Pub. Date: Apr. 10, 2008**

(54) **PLANT HANGER**

Publication Classification

(76) Inventors: **John Conroy**, Naples, FL (US); **J. Thomas Conroy**, Naples, FL (US)

(51) **Int. Cl.**
A47B 96/00 (2006.01)

(52) **U.S. Cl.** **248/227.3; 248/230.3; 248/231.41**

(57) **ABSTRACT**

Correspondence Address:
SNIDER & ASSOCIATES
P. O. BOX 27613
WASHINGTON, DC 20038-7613

A hanger with an integral U shaped clamping device for attachment to a metal support of a screened enclosure. The clamping device includes one resilient lined sidewall of which is movable by means of a hand-operated screw in order to clamp the hanger to the support. The resilient interior walls of the clamp provide a solid yet non-damaging surface area to hold the hanger securely to a vertical support structure of a screen enclosure.

(21) Appl. No.: **11/542,109**

(22) Filed: **Oct. 4, 2006**

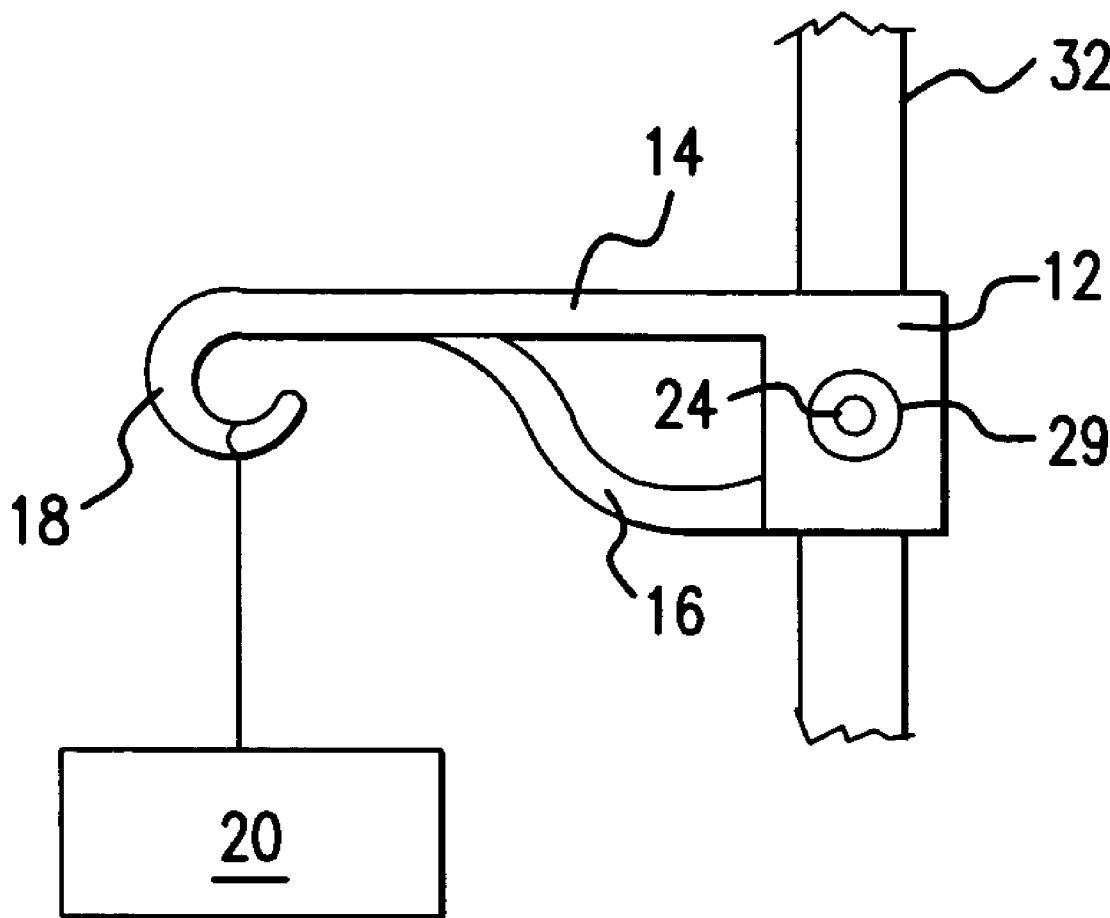

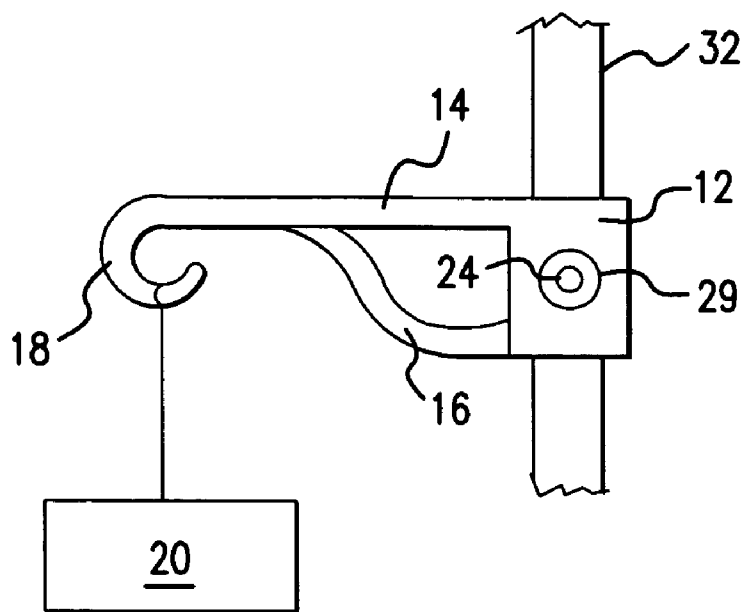

FIG. 1

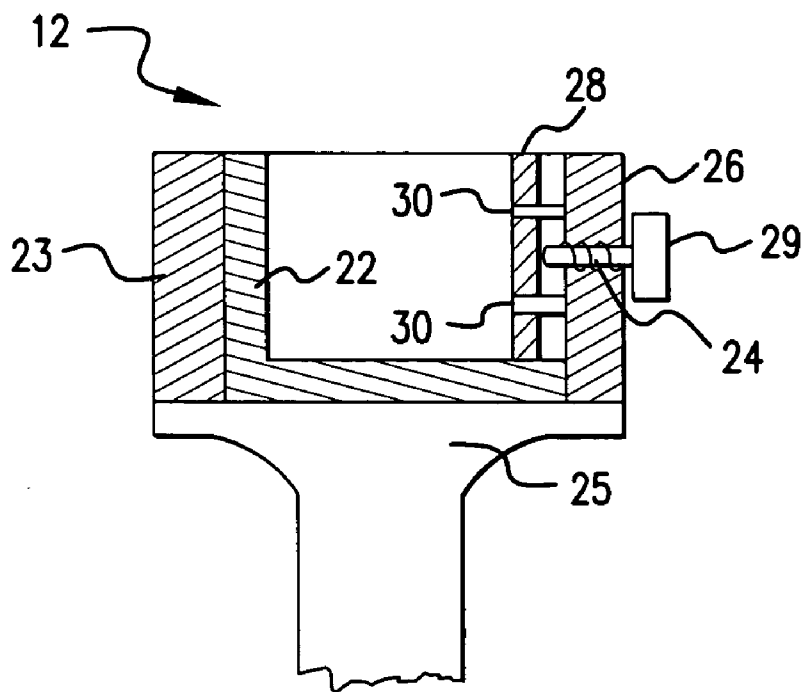

FIG. 2

PLANT HANGER

FIELD OF THE INVENTION

[0001] This invention relates to an improved hanger for a container that holds flowers, plants, and similar items, and more particularly to a hanger for attachment to a metal stanchion such as a vertical support for a screened enclosure.

BACKGROUND OF THE INVENTION

[0002] In the prior art there are a number of hangers for suspending above the ground containers for flowers, plants, and the like. While generally satisfactory, they are not satisfactory for use in enclosures supported by a metal frame, such as screened enclosures commonly referred to as a lanai.

SUMMARY OF THE INVENTION

[0003] An object of this invention is the provision of an improved hanger that can be attached to a frame member without damaging the member.

[0004] Briefly, this invention contemplates the provision of a hanger with an integral U shaped clamping device for attachment to a metal support of a screened enclosure. The clamping device includes one resilient lined sidewall of which is movable by means of a hand-operated screw in order to clamp the hanger to the support. The resilient interior walls of the clamp provide a solid yet non-damaging surface area to hold the hanger securely to a vertical support structure of a screen enclosure. In a preferred embodiment of the invention, the hanger and clamp comprise a single plastic piece with a cantilevered arm extending from the top of the clamp and a brace that supports the arm extending from the bottom of the clamp upward to the arm.

[0005] The objects, advantages and novel features of the present invention are apparent from the following detailed description when read in conjunction with the appended claims and attached drawings.

BRIEF DESCRIPTION OF THE DRAWINGS

[0006] FIG. 1 side view of a hanger in accordance with the teachings of this invention attached to a vertical metal frame member of an enclosure, such as a screened enclosure.

[0007] FIG. 2 is a top view of the clamp portion of the hanger shown in Figure with parts shown in section.

DESCRIPTION OF THE PREFERRED EMBODIMENT OF THE INVENTION

[0008] Referring now to the drawings, the hanger is comprised of a U shaped clamp 12 with an upper cantilever arm 14 extending from the top of the clamp and a bracing strut 16 extending from bottom of the clamp upwardly to engage the arm 14. The arm 14 terminates in a downward hook 18 from which a basket or container 20 may be hung. These components of the hanger are preferably made from a single integral plastic piece. As best shown in FIG. 2, the interior wall of clamp 12 is lined on one sidewall 23 and on the back wall 25 with a resilient material 22, such as rubber. A screw 24 is screws into the other wall 26 so that one end of the screw engages a plastic pad 28. A knob 29 attached to the other end of the screw 24 is sufficiently large that it can be easily turned by hand. Holes in the plastic pad 28 accept guide pins 30 secured to wall of the clamp.

[0009] In operation, as the screw 24 is tightened, the pad 28 forces the wall of the rectangular structural member 32 (shown in FIG. 1) into tight engagement with the resilient material on sidewall 23, thus locking the hanger in place without damage to the structural member 32. It will be noted the hanger can be removed by rotating the screw 24 in the opposite direction.

- 1. (canceled)
- 2. A hanger as in claim 3 wherein said pad is attached to said other sidewall by pins extending from said other sidewall.
- 3. A hanger to be attached to and to be supported from a structural member comprising in combination: a U-shaped clamp with an integral arm extending at one end from the top of said U-shaped clamp and terminating at its other end in a hook; an integral strut extending from the bottom of said U-shaped clamp so that said strut engages said arm with said hook curving inward toward said strut to allow a container to be suspended from said hook; said U-shaped clamp including a resilient material on one side wall interior; and a movable pad and screw attached to an opposite side wall so that when the screw is tightened the pad moves in order to secure the hanger to the structural member without damaging it.

* * * * *