

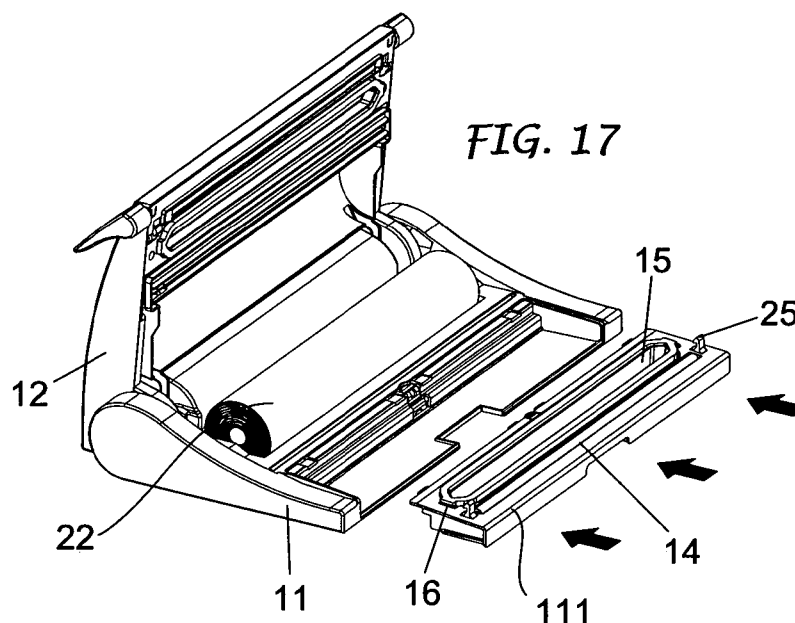

- (51) International Patent Classification:  
B65B 31/02 (2006.01)
- (21) International Application Number:  
PCT/IT2010/000250
- (22) International Filing Date:  
4 June 2010 (04.06.2010)
- (25) Filing Language:  
Italian
- (26) Publication Language:  
English
- (30) Priority Data:  
BS2009A000103 11 June 2009 (11.06.2009) IT
- (71) Applicant (for all designated States except US): **FLAEM NUOVA S.p.A.** [IT/IT]; Via Colli Storici 221-223-225, 25010 S. Martino Della Battaglia (BS) (IT).
- (72) Inventors; and
- (75) Inventors/Applicants (for US only): **ABATE, Luigi** [IT/IT]; c/o Flaem Nuova S.p.a., Via Colli Storici 221-223-225, I-25010 S. Martino Della Battaglia (BS) (IT). **ABATE, Riccardo** [IT/IT]; c/o Flaem Nuova S.p.a., Via Colli Storici 221-223-225, I-25010 S. Martino Della Battaglia (BS) (IT). **BERTELLI, Mauro** [IT/IT]; c/o Flaem Nuova S.p.a., Via Colli Storici 221-223-225, I-25010 S. Martino Della Battaglia (BS) (IT).
- (74) Agent: **SANGIACOMO, Fulvia**; c/o Biesse S.r.l., Corso Matteotti, 42, I-25122 Brescia (IT).
- (81) Designated States (unless otherwise indicated, for every kind of national protection available): AE, AG, AL, AM, AO, AT, AU, AZ, BA, BB, BG, BH, BR, BW, BY, BZ, CA, CH, CL, CN, CO, CR, CU, CZ, DE, DK, DM, DO, DZ, EC, EE, EG, ES, FI, GB, GD, GE, GH, GM, GT, HN, HR, HU, ID, IL, IN, IS, JP, KE, KG, KM, KN, KP, KR, KZ, LA, LC, LK, LR, LS, LT, LU, LY, MA, MD, ME, MG, MK, MN, MW, MX, MY, MZ, NA, NG, NI, NO, NZ, OM, PE, PG, PH, PL, PT, RO, RS, RU, SC, SD, SE, SG, SK, SL, SM, ST, SV, SY, TH, TJ, TM, TN, TR, TT, TZ, UA, UG, US, UZ, VC, VN, ZA, ZM, ZW.
- (84) Designated States (unless otherwise indicated, for every kind of regional protection available): ARIPO (BW, GH, GM, KE, LR, LS, MW, MZ, NA, SD, SL, SZ, TZ, UG, ZM, ZW), Eurasian (AM, AZ, BY, KG, KZ, MD, RU, TJ, TM), European (AL, AT, BE, BG, CH, CY, CZ, DE, DK, EE, ES, FI, FR, GB, GR, HR, HU, IE, IS, IT, LT, LU, LV, MC, MK, MT, NL, NO, PL, PT, RO, SE, SI, SK, SM, TR), OAPI (BF, BJ, CF, CG, CI, CM, GA, GN, GQ, GW, ML, MR, NE, SN, TD, TG).
- Published:  
— with international search report (Art. 21(3))

[Continued on next page]

(54) Title: APPARATUS FOR CREATING A VACUUM IN CONTAINERS



(57) Abstract: The invention concerns an apparatus for creating a vacuum in containers, both flexible like bags, and rigid, for the preservation of vacuum packaged products. It comprises a base plate (11) having a front part separable and behind the suction chamber (15), a notch (21) designed to house a roll (22) of a tubular element extractable from the front of the apparatus and cut using a trimmer (23) placed on board a casing or cover (12) above the base plate. Furthermore, a connecting device (13) is provided between the base plate and the casing or cover for blocking the apparatus in at least two different closing position conditions

WO 2010/143216 A1

- *before the expiration of the time limit for amending the claims and to be republished in the event of receipt of amendments (Rule 48.2(h))*

**“APPARATUS FOR CREATING A VACUUM IN CONTAINERS”**

\* \* \* \* \*

**Field of the Invention**

This invention concerns improvements to an apparatus for creating a vacuum in containers, both flexible like bags, and rigid like jars or canisters, designed to preserve vacuum-packed products.

**5 State of the Technique**

To create a vacuum in containers in general and for the abovementioned use, an apparatus, among others, is already available that basically comprises a base plate defining at least a part of a suction chamber, and a casing or overhanging cover, that defines a remaining part of said  
10 suction chamber and that is provided with

a vacuum pump,

a sealing bar, and also

control and management devices of the various functions of the apparatus.

15 The upper casing or cover is associated with the base plate and is moveable by rotating it above the latter between an opening and closing positions of the suction chamber whereas the lower plate, if required, can be completely removed so as to be washed separately from the casing or cover, consequently without involving the vacuum pump or even more important the  
20 electric or electronic components that always remain closed and protected in the casing or cover.

Such an apparatus, agreed that its overall configuration with the vacuum pump, sealing bar and control and management apparatus of the various functions present in the upper casing or cover, was however found to be susceptible to improvements to increase its performance plus its  
5 functionality and practicality.

On the other hand the documents US2005/050856; DE 34 03534; EP 1990 280; EP 1564 148 appear to be indicative of the present state of the technique.

### **Objective and Summary of the Invention**

10 It is therefore an objective of this invention to provide a apparatus that meets the abovementioned type for the formation of a vacuum, at least in flexible containers such as bags, incorporating a decomposable flat base, an original closing and releasing blocking device between the base plate and upper casing or cover, a roll carrier space on the base plate and a cutter  
15 associated with the casing or cover and which can move towards the flat base.

This objective is achieved, according to the invention with an apparatus for the formation of the vacuum in bags or canister according to at least claim  
1.

20 In this way, the base plate instead of being completely separable from the casing or cover, can comprise only a removable and washable part, in particular a part defining a basin to collect the fluids or substances that may flow out of the container during the suction phase to create a vacuum.

Furthermore, for its operation, the blocking and releasing apparatus  
25 can be provided with one or more maneuvering levers or knobs which can be

used individually or both at the same time, so that the closing of the apparatus to be used and then opening it after being used can both be carried out either using only one hand or using two. In addition, the block and release devices can be associated with means for the control of other functions, such as the control of a micro switch provided to enable the functioning of the device only after it has been trimmed and blocked on closing and, where required, the command of an air valve so as to close it when the equipment is in use and to immediately open it before the equipment is opened following use.

#### 10 **Brief description of the Drawings**

The invention will however be described in greater detail in the following making reference to the attached explicative drawings, in which:

Figs. 1 and 2 show the apparatus closed respectively in a vertical rest position and in a laying down position:

15 Fig. 3 shows the apparatus in a release phase to be opened;

Fig. 4 shows the apparatus open for use and complete with a roll of a tubular element for the formation of bags;

Fig. 5 shows an internal view of an initial equipment of an apparatus complete with a block/release device, solenoid valves and a micro switch;

20 Fig. 6 shows an internal view of a second preparation of an apparatus complete with a block/release, air valve and micro switch;

Figs. 7, 8 and 9 show a detail of the block/release device between base plate and upper casing in the inactive, intermediate and active positions visible respectively according to the cross section line A-A in Figs. 5 and 6;

25 Figs. 10, 11 and 12 show a detail of the control system of the air valve

in the open, intermediate and closed positions respectively, according to the section line B-B in Figs. 5 and 6;

Fig. 13 shows a view of the apparatus open in an extraction and cutting phase of a length of tubular element;

5 Fig. 14 shows a view of the apparatus in which the base plate is completely separated from the upper casing or cover;

Fig. 15 shows a version of the apparatus in which the base plate has only one removable portion;

10 Figs. 16 and 17 show in sequence the separable part in the extraction phase and totally removed from the flat base: and

Fig. 18 shows an enlarged detail of the sealing bar and the respective packing.

### **Detailed Description of the Invention**

15 The apparatus represented comprises a base plate 11 to which is coupled an upper casing 12, or cover, rotating between a raised opening position above the base plate and a lowered closed position, that is to say operative, in which the upper casing or cover, becomes blocked on the base plate by means of a clamping device 13 which will be described further on.

20 According to an embodiment, the base plate 11 and the casing or cover 12 are connected to each other, but separable one from the other, as shown in Fig. 14, to enable the manipulation and the washing of the first independently from the second.

25 The base plate 11 carries on its upper face, adjacently to its front side, a profiled contrary gasket 14 and parallel, behind the latter, it has an oblong slot 15, possibly enclosed by a seal 16 facing upwards. Basically, the slot 15

can act as a receptacle for collecting possible fluid substances that can be sucked and exit from a container during the formation of the vacuum. However, in the slot 15 there could be provided, even though not shown, a tank for collecting fluid substances. This tank will preferably be removable so as to be cleaned and provided, or not, with a rod to hold the mouth of a flexible container in position.

In the casing or cover 12 are positioned—Figs. 5 and 6— a vacuum pump P, a pressure switch T, at least one solenoid valve EV and all the functional components, pneumatic and electric commands and controls of the various work phases of the apparatus. Furthermore, these components could be integrated that is to say pre-assembled on a support panel to facilitate the realization of the machine. On an upper wall of said casing or cover 12 an instrument board 17 is provided with instruments and pushbuttons which enable the user to manage the machine and its functions according to requirements.

The casing or cover 12 delimits, in a part of its lower face, an aspiration chamber 18 that, for example, is connected by means of a multi-way block 118 -Figs. 10- 12- to the vacuum pump P according to the F arrow, to a pressure switch T according to arrow G and to a breather pipe S according to the H arrow. The suction chamber 18 is in turn, surrounded by a seal 19 which faces towards and coincides with the seal 16 placed either around the slot 15 or, where envisaged, the tank on the base plate 11. Furthermore, on the front of the suction chamber 18, the casing or cover 12 holds a sealing bar 20 which, when the machine is closed, coincides with a profiled contrary gasket 14 on the base plate 11. Preferably, the sealing bar 20 rests on flexible

means, for example leaf springs 120 –Fig. 18- operating to push said sealing bar towards the contrary gasket 14 supported by the base plate 11. This layout enables the sealing operation to be carried out more easily even in the lack of suction on the part of the pump that is to say that the vacuum pump not operating. In fact the thrust of the flexible means 120 on the sealing bar permits, in all cases, to maintain the two opposite faces near each other so that they can be sealed.

Between the base plate 11 and the upper casing, a space designed to house a roll 22 of a tubular element is provided in addition and is gradually extractable from the front of the apparatus which from time to time cuts a length 22' -Fig. 13- for the preparation of a bag at the required length at the time of packaging the products that need to be preserved. As shown -Fig. 4- this space is delimited by a notch 21 on the back of its slot 15, or tank, together with a roll cover element 21', which is reclining, and is mounted inside the upper casing 12. On the other hand, a cutter 23 is associated with the upper casing or cover 12, which in the example illustrated has a frame associated with the abovementioned roll cover 21' and in the illustrated example has a frame associated with the abovementioned roll cover element 21' and is a turn-up with the latter. Practically, with the apparatus open the cutter moves into a vertical idle position, accosted to the casing 12, whereas when turning the roll-cover element 21' moves towards the base plate 11, the cutter moves into a horizontal rest position on the tubular element which from time to time is taken from the roll 22 for the transversal cutting of the latter.

In a variation in construction as shown in Figs. 15-17, the base plate 11 is not completely separable from the casing or cover above, but only partially.

It, in fact has an autonomous front portion, 111, which is for example coupled like a drawer with the remaining part of the base plate 11 and which is extractable to be washed separately from other parts of the apparatus. In this case, the placing of the roll carrier space being understood, it is the front portion 111 that is configured to carry the profiled packing 14 that acts as a locator for the sealing bar 20 and to delimit the slot 15 surrounded by the seal 16 facing the suction chamber 18 defined by the upper casing.

The connecting device 13 mentioned above for blocking the casing or cover 12 when closing on the base plate 11 -Fig. 7-9- consists in two fixed hooks 25 and in two corresponding swivel hooks 26. The fixed hooks 25 extend upwards from opposite parts of the base plate 11 close to its front side or, when present, from the removable portion 111. For their rotation, the swivel hooks 26 are mounted on respective pins 29 and are connected to a turning control shaft 27 by means of an articulation made up of relay rods 30, 31, and 32.

The control shaft extends crossways and is supported in rotation in the casing or cover 12, by means of bushings or bearings.

The swivel hooks 26 are movable between an inactive unblocked position, in which they are at a distance from the fixed hooks -Fig. 7-, and an active blocked position, in which they are drawn near and are closely connected with the fixed hooks -Fig. 9-, by means of a possible intermediate position -Fig. 8- in which hooks and swivel hooks ensure, not so much a clamping, but simply a nearing of the casing or cover on the base plate.

As represented, the control 27 shaft of the swivel hooks 26 can be a sole item and provided for its manual rotation with levers or end grips 28

positioned externally on the casing or cover 12.

The rotation of the shaft can be carried out manually on one or the other lever or grips or on both at the same time.

As an alternative, in the place of a single control shaft there can be provided two independent semi-shafts each designed to control a counter hook 26 and each provided with a relative lever or grip 28; the two semi-shafts with the relative swivel hooks will in this case be independent, but the block and release of the apparatus when closed may be carried out only by operating on both the levers or grips.

According to another aspect of the invention and regarding a first set up – Fig. 5 – to the apparatus to create a vacuum is also keyed a cam 127 to the shaft 27 or to one of the two semi-shafts, provided to control the block/release 26 swivel hooks.

This cam is set up to engage with a cursor 128 -Figs 10-12- which is placed in the casing or cover 12 of the apparatus and helped by means of a relative guide support 129 and configured to control at the same time a bleed valve 130 associated with the bleed hole on a level with the multiway block and a micro switch 131. In a different set up, the apparatus can be without a bleed valve; in this case the cam fixed to the shaft 27 or to one of the two control semi-shafts of the block/release swivel hooks is always controlled by a cursor, but this is provided only to interact with a micro-switch.

In both cases the micro-switch is inserted in the electric circuit of the apparatus with the aim of enabling the start of the functions of the apparatus itself only when it is blocked and closed, releasing them on the other hand when the apparatus is open.

The apparatus described above can be programmed to carry out, by means of appropriate selection controls available on the instrument board 17, for example: all the automatic vacuum formation cycle and sealing starting from a bag with a closed bottom; a shortened soldering and sealing cycle in advance before reaching the maximum vacuum allowed in a flexible container; a soldering cycle without precautionary starting of the vacuum pump when initial sealing of a tubular element to dissect for the preparation of bags is required; a shortened cycle only for the formation of a vacuum in containers that are rigid, positioned outside of the apparatus and connected to it by means of a suction tube.

When the apparatus is not needed, it can be closed, positioning the connecting device in an intermediate blocked condition –Fig. 8, and laid down horizontally as in Fig. 1 or placed vertically against the rear side, as in Fig. 2.

When required for use, the apparatus is opened by using at least one of the levers or grips 28 –according to the arrows in Fig. 3- in the direction to release the connecting device 13 and turn the casing or cover 12 above the base plate 11 -Fig. 4. At that point, if present, it is possible to extract a length of tubular element from the roll 22 until the end is almost in line with the rear side of the base plate; then close and block the casing or cover 12 on the base plate 11 using the connecting device 13. With the closing of the apparatus, the cam 127 sets, by means of the slider 128, the closing of the micro switch 131 to enable the use of the apparatus. Therefore it is possible to select and proceed with a soldering cycle only, without starting the vacuum pump, to seal the initial part of the tubular element; then re-open the apparatus so as to extract a portion 22' of tubular element at the required

length -Fig. 13- and be able to then lower the trimmer 23 to trim crossways  
the length of the portion 22' from the tubular element so as to be able to have  
a bag with a closed bottom available. This bag can then be used to arrange  
the product to be wrapped, after which its open entrance can be placed  
5 between the base plate and the casing or cover so as to be in line with the  
suction chamber. Now, the casing or cover is lowered onto the base plate and  
blocked on closing by means of a connecting device. So, on the one hand the  
bleed valve 130 is moved into the closed position of the bleed hole; on the  
other hand, the micro-switch is closed to enable the operation of the  
10 apparatus; consequently the vacuum pump can be started to remove the air  
from the bag through the suction chamber and, once the empty level required  
in the bag has been reached, the soldering phase for the final sealing of the  
mouth of the bag is started before releasing the connecting device again to  
be able to re-open the apparatus and remove the sealed packet.

## CLAIMS

1. Apparatus to create the vacuum in containers, both flexible such as bags, and rigid such as vases or canisters, for the preservation of vacuum-packed products, comprising a base plate (11) and a cover (12) joined together, where the cover is movable by rotation compared with the other raised inactive open position, and a lowered closed operating position, and where the base plate and the cover are associated to delimit, in the closed position, a suction chamber (18) designed to receive the mouth of a flexible container to be put in a vacuum by a vacuum pump and be sealed by means of a sealing bar (20) with the help of mechanical control, pneumatic, electric and electronic means, **characterized by the fact that the base plate (11) is connected to the casing or cover(12) and has a separable front portion (111) so that it can be manipulated and washed separately from a remaining part of the base plate.**

2. Apparatus according to claim 7, characterized by the fact that said separable portion (111) is placed and guided in a front part of the base plate (11) and provided at least with a receptacle (15) for liquid substances designed to coincide with the suction chamber (18), and with a profiled contrary gasket (14) for the sealing bar (20) when the apparatus is closed, said receptacle being made up of a slot and surrounded by a gasket (16).

3. Apparatus according to claim 1 or 2, characterized by the fact that - between the base plate and the cover overhead is provided a

connecting device (13) for blocking the apparatus in at least two different closing conditions;

- said connecting device (13) comprises two fixed hooks (25), that extend upwards from the base plate (11) and two corresponding swivel hooks (26) operated by a control shaft (27) supported crossways in said casing or cover (12) and equipped with levers or end ball grips (28), e

- said swivel hooks (26) turn on respective pins (29) between an idle released position and an active blocked position with the fixed hooks, by means of a possible intermediate simple stop position of the cover on the base plate.

3. Apparatus according to the previous claims, in which the fixed hooks (25) are fastened to the base plate (11).

5. Apparatus according to claims from 1 to 3, in which the fixed hooks (25) are fixed to the front separable portion (111) of the base plate (11).

6. Apparatus according to claim 3, characterized by the fact that said control shaft (27) is a single piece, that the swivel hooks (26) for their rotation in each of said positions are connected to the control shaft (27) by means of idler arm (30, 31, 32), and that the levers or grips (28) are fixed to the ends of said shaft.

7. Apparatus according to claim 3, characterized by the fact that said control shaft (27) is made up of two independent semi-axes, which every counter hook (26), for its rotation in each of said positions, is connected to a respective semi-shaft by means of an idler arm (30, 31, 32), and that the levers or grips (28) are each fixed to a respective semi-axis.

8. Apparatus according to claims 3, 6 or 7, characterized by the fact

that to said shaft is fixed a cam (127) associated with a slider (128) movable and interacting with at least a micro switch (131) set up to enable the start of the functions of the apparatus only when it is in the exact strict closed blocked position.

5           9. Apparatus according to claims 3, 6 or 7, characterized by the fact that to said shaft is fixed a cam (127) associated with a cursor (128), movable and interacting with a micro switch (131) designed to enable the start up of the functions of the apparatus only when it is in the strict closed blocked position, and with a bleed valve (130) provided to connect the suction  
10 chamber with the atmosphere when the apparatus is in the open position.

10. Apparatus according to any of the previous claims, characterized by the fact that the suction chamber (18) and the sealing bar (20) are on board the cover (12) and facing towards the base plate (11), and that at least the base plate (11) is provided with a housing (21) designed to receive a roll (22) of a  
15 tubular element which can be trimmed by a trimmer (23) for the preparation of bags at the required length.

11 Apparatus according to claim 10, characterized by the fact that the base plate is provided in a part in front of said housing (21) with at least a receptacle for liquid substances, designed to coincide with the suction  
20 chamber (18) on board the cover, and with a profiled contrary gasket (14) for the sealing bar (20) when the apparatus is closed, said receptacle being provided with a slot or a removable small basin.

12. Apparatus according to any of the previous claims, characterized by the fact that the sealing bar (20) is stimulated by flexible means (120)  
25 tending to push it towards a contrary gasket (14) when the apparatus is

closed.

13. Apparatus according to claim 6; characterized by the fact that the trimmer(23) can overturn around a horizontal axis from an idle position near said casing in a horizontal supporting position on the tubular element drawn  
5 from the roll to be cut crossways.

14. Apparatus according to claim 10, characterized by the fact that the trimmer is associated with a turnoverable element (21') associated with said upper casing and having a concurrent cavity to define the role carrier with the cavity (21) on the back of the suction chamber.

10 15. Apparatus according to claim 1 and any of the claims from 1 to 9, characterized by the fact that at least the vacuum pump and the pneumatic, electric and electronic means are integrated on a supporting panel.

1/8

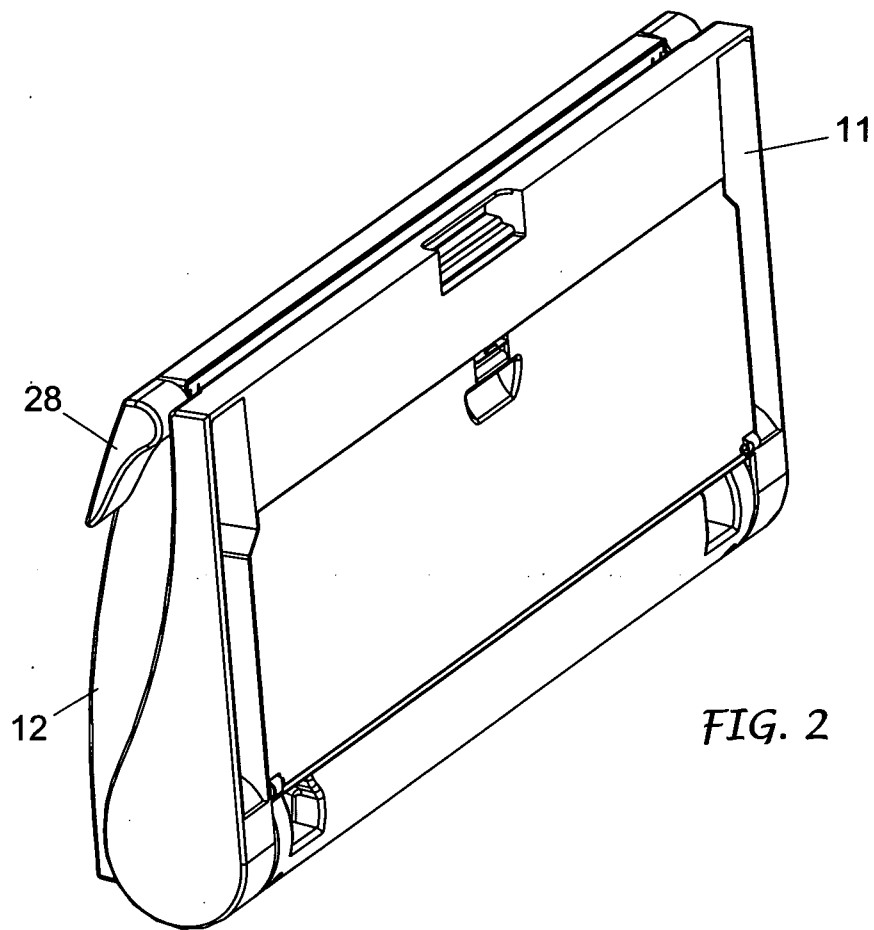
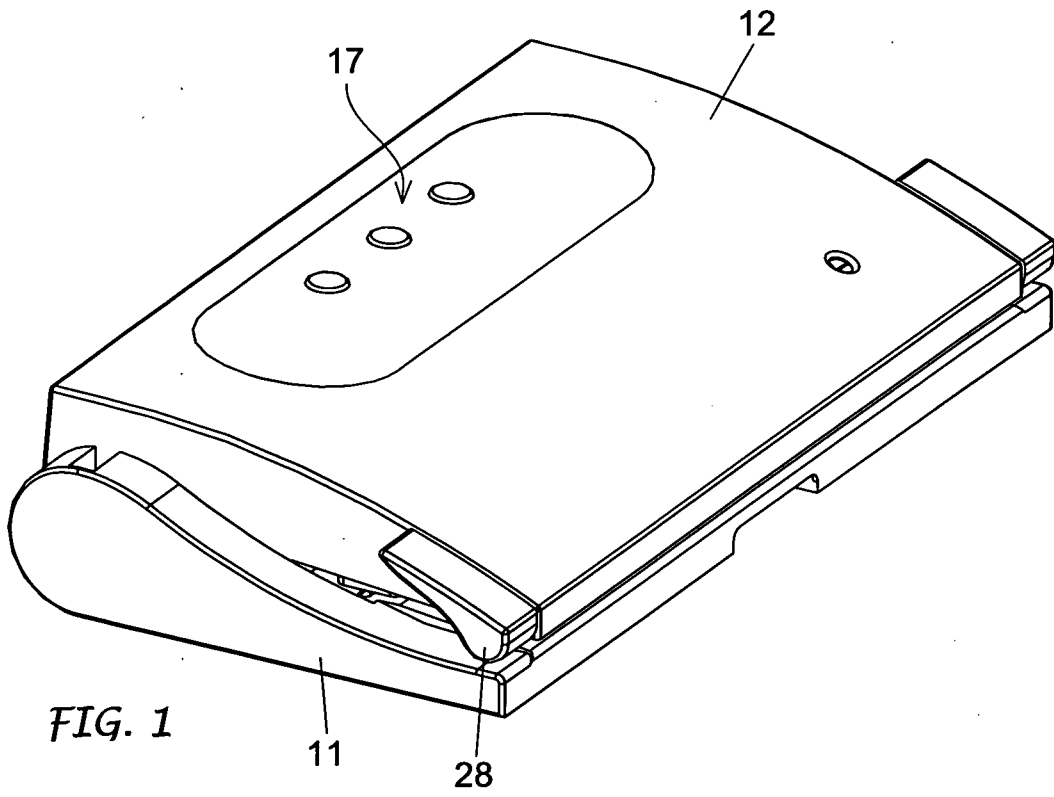

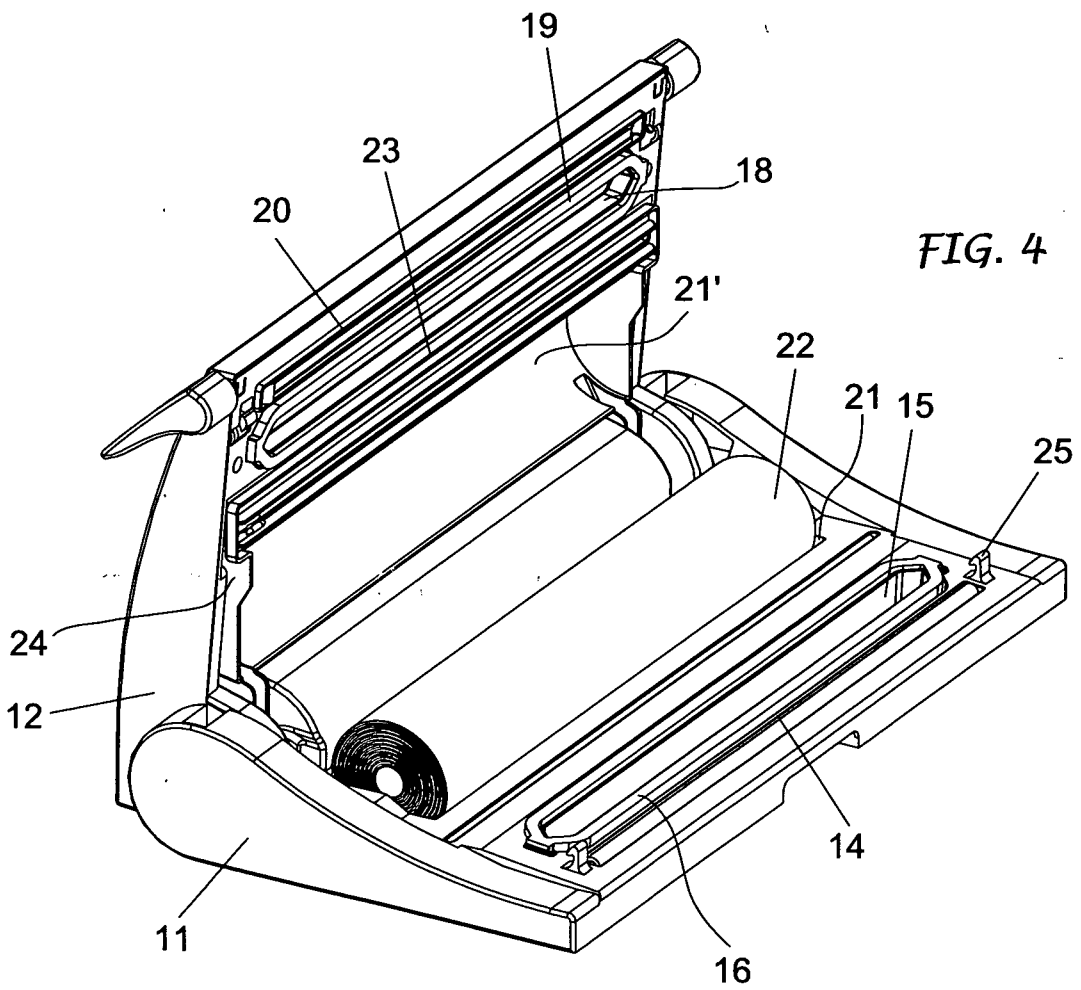
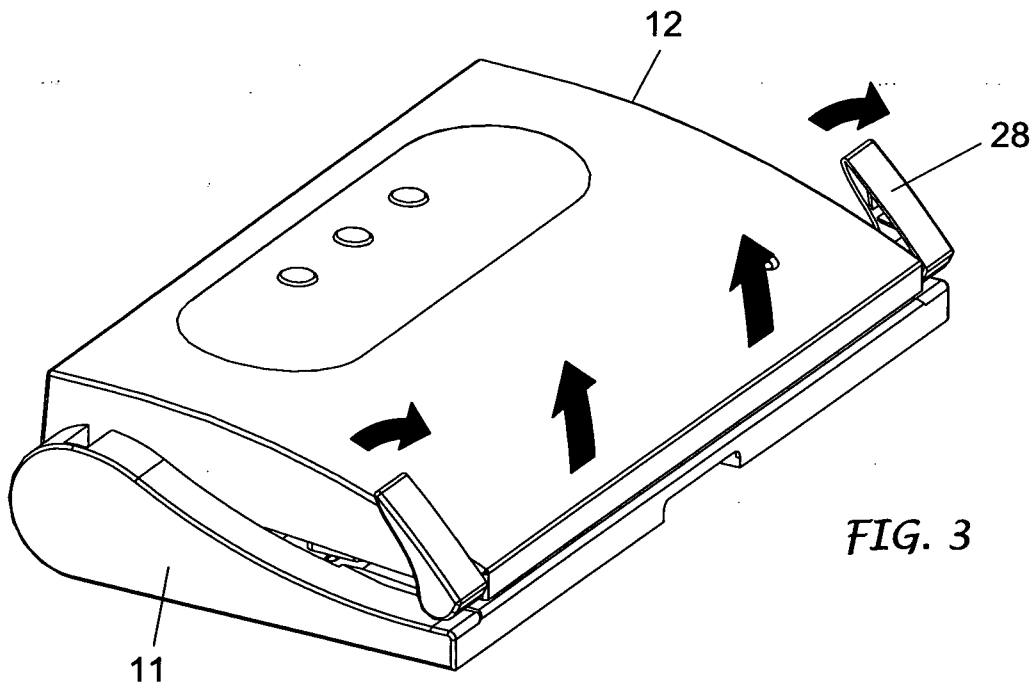

FIG. 5

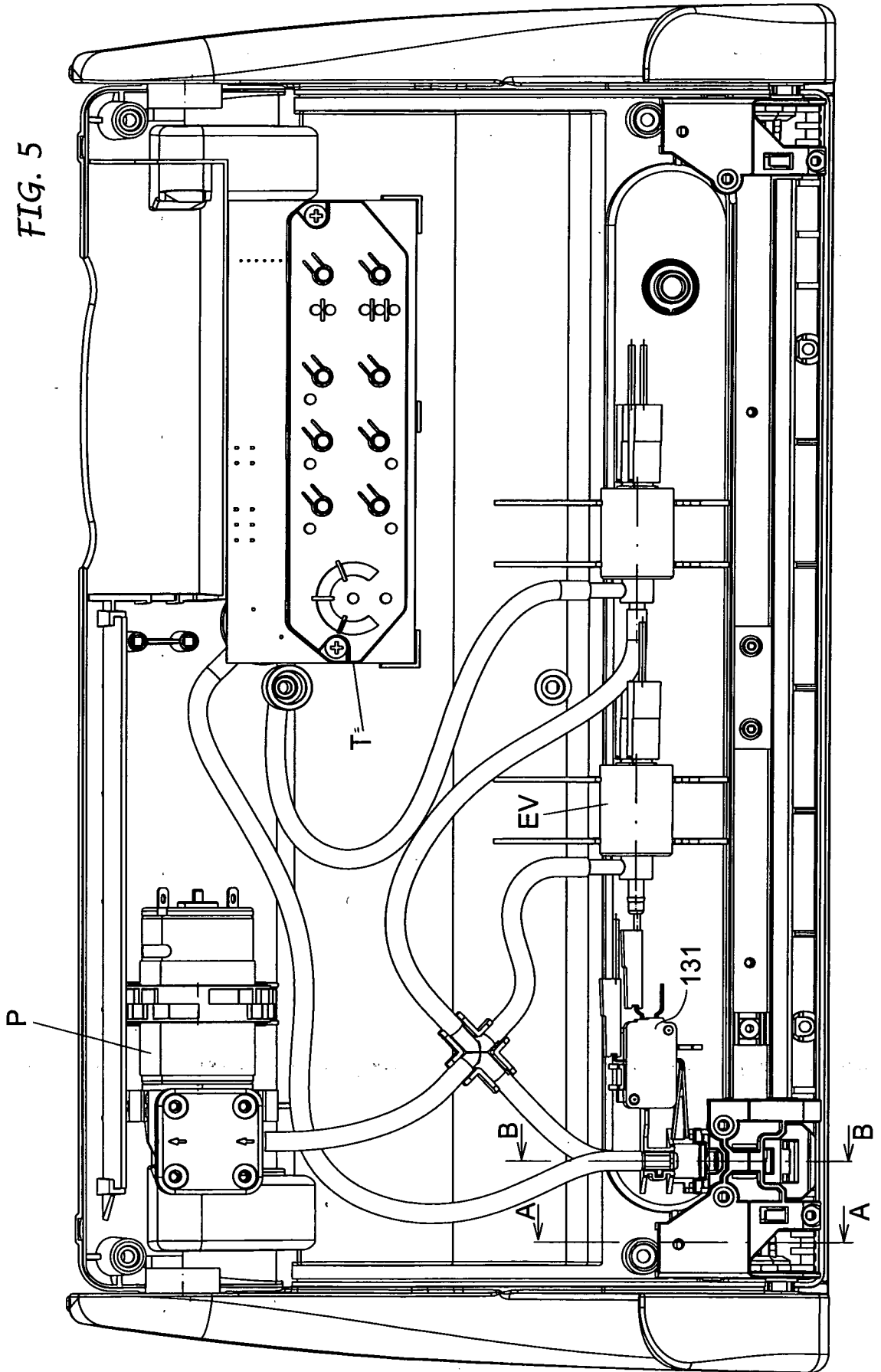
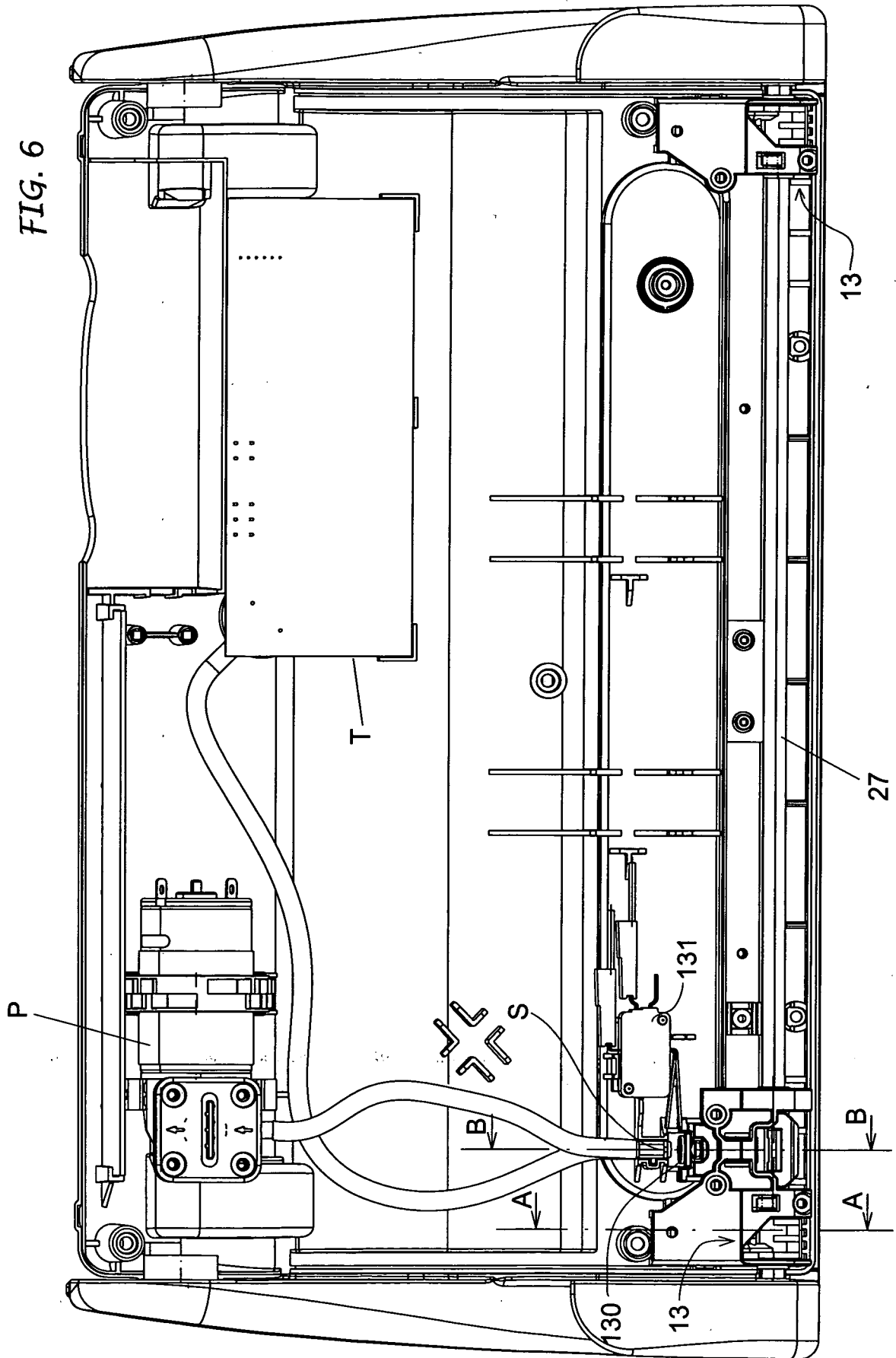

FIG. 6



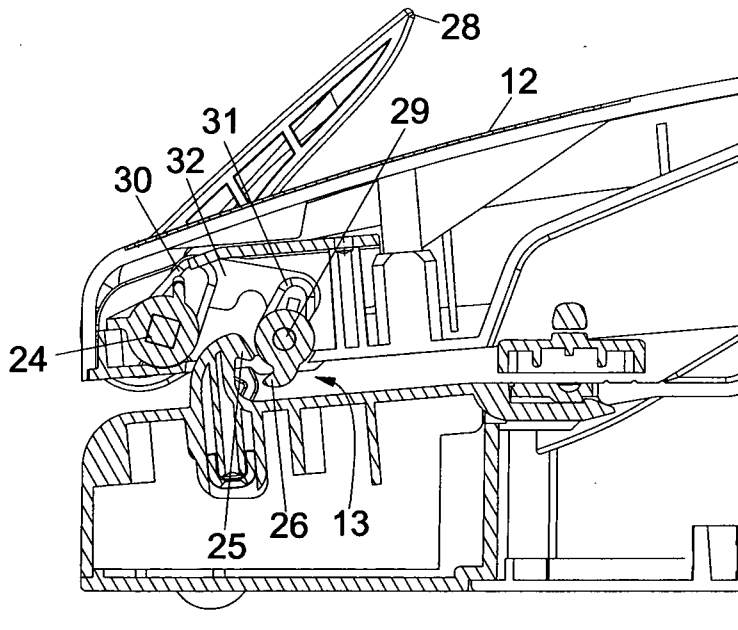

FIG. 7

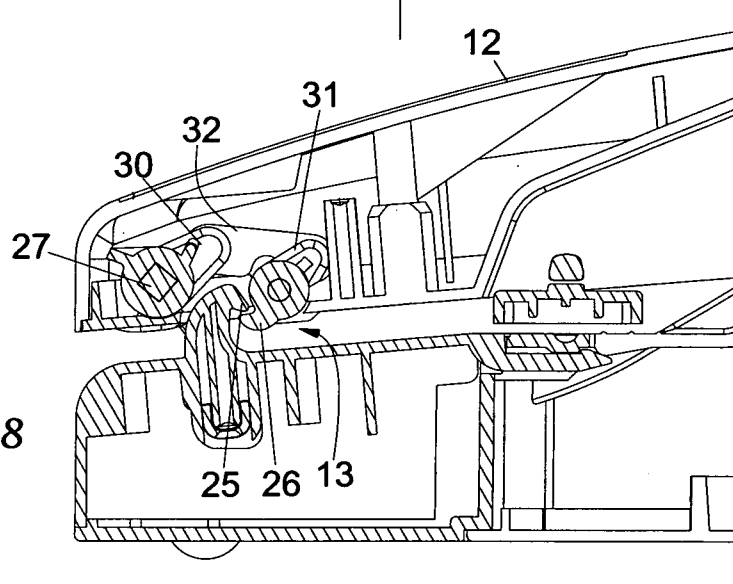

FIG. 8

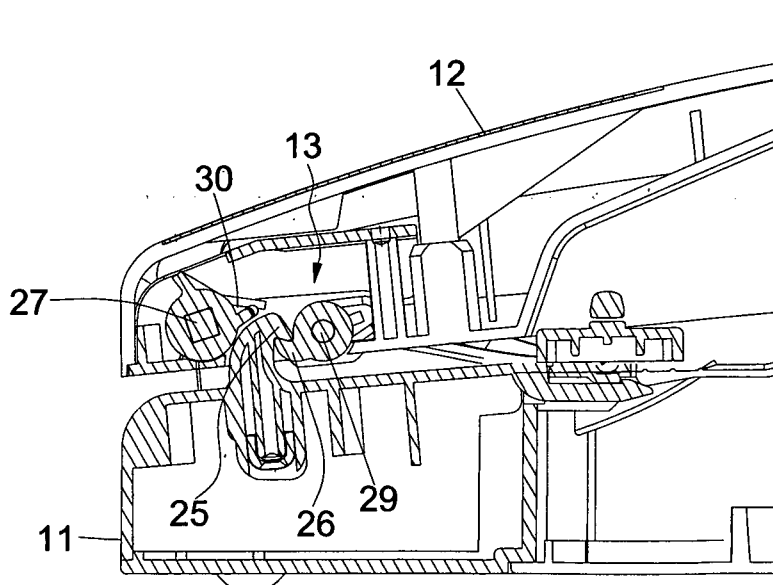
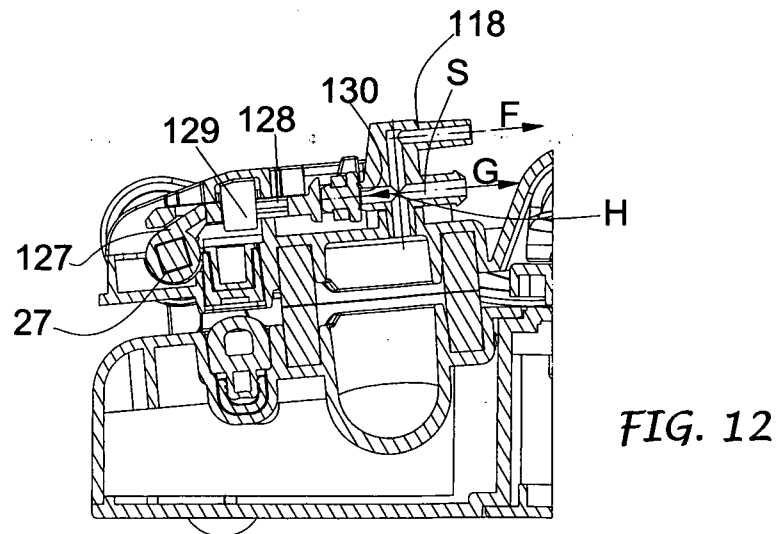
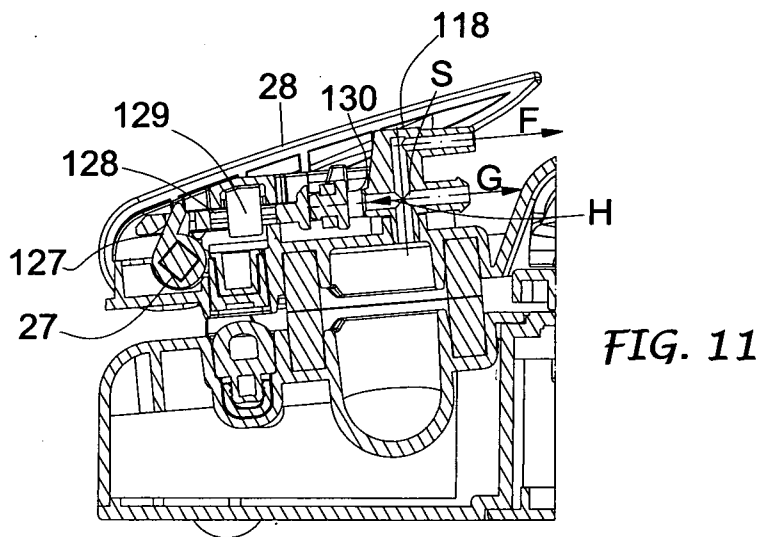
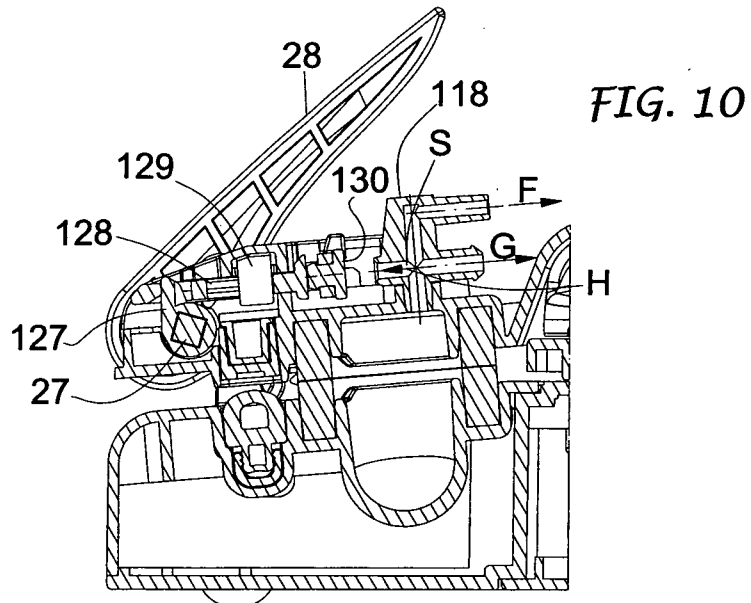

FIG. 9



7/8

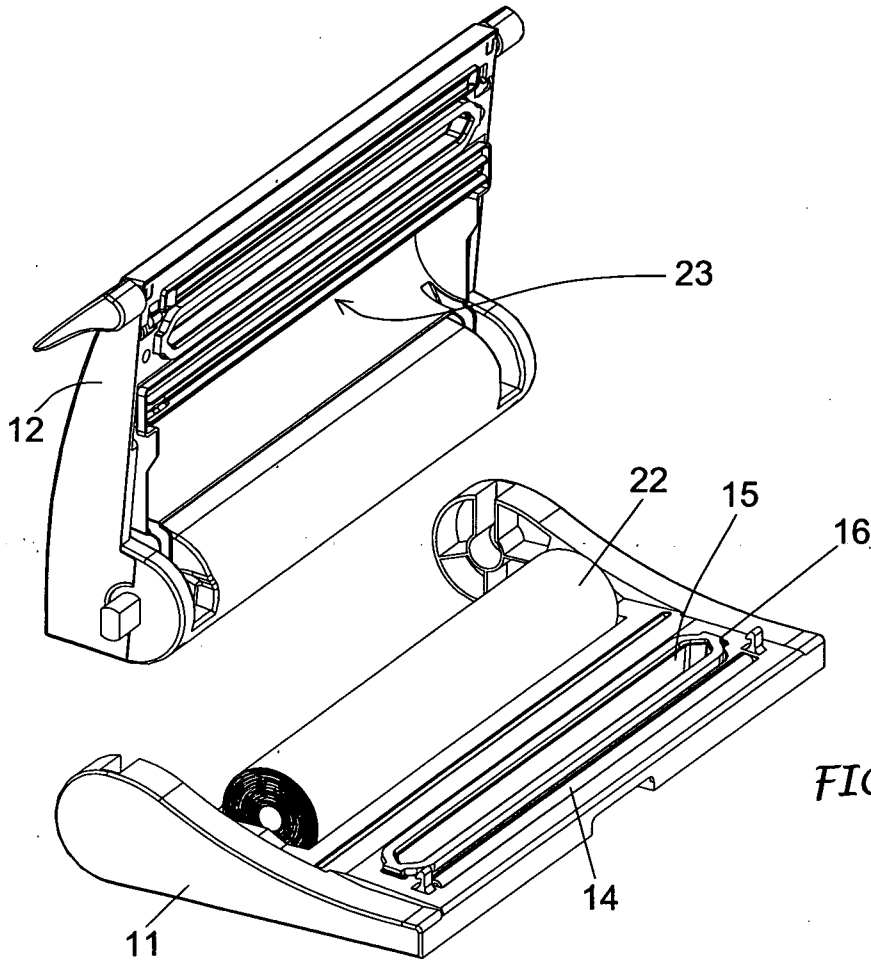
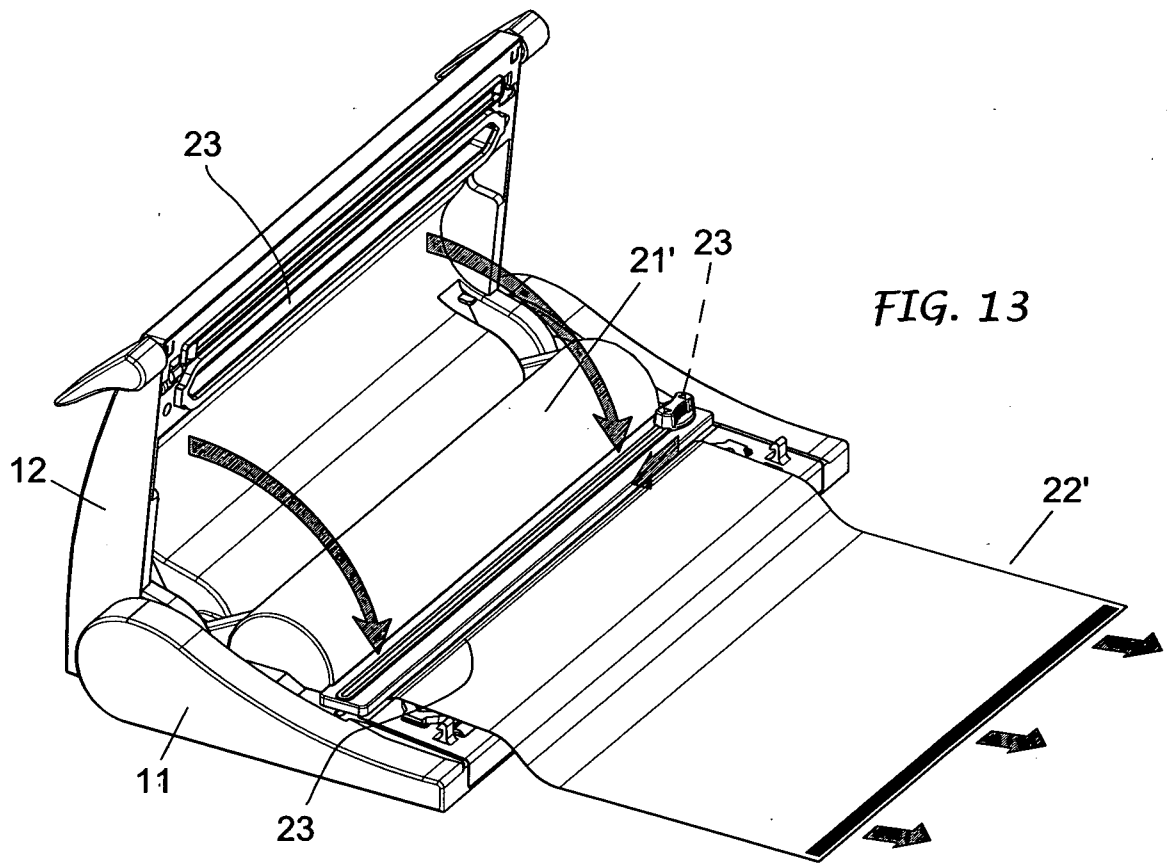

FIG. 14

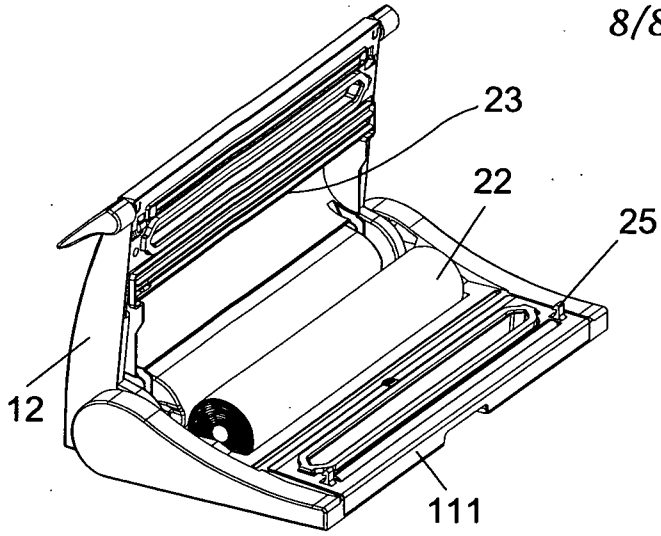

FIG. 15

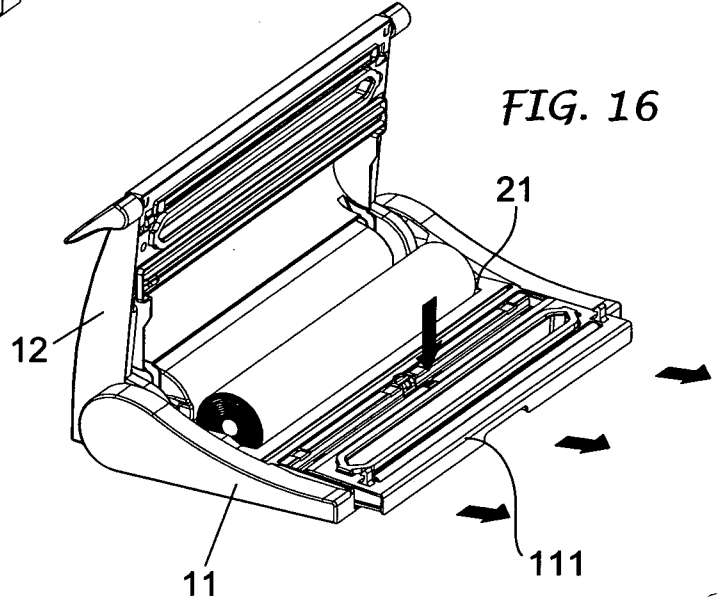

FIG. 16

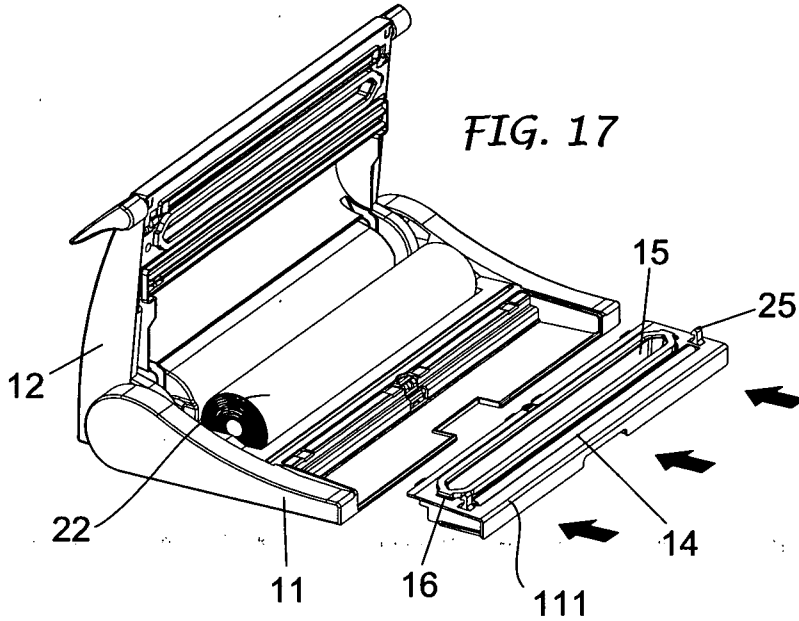

FIG. 17

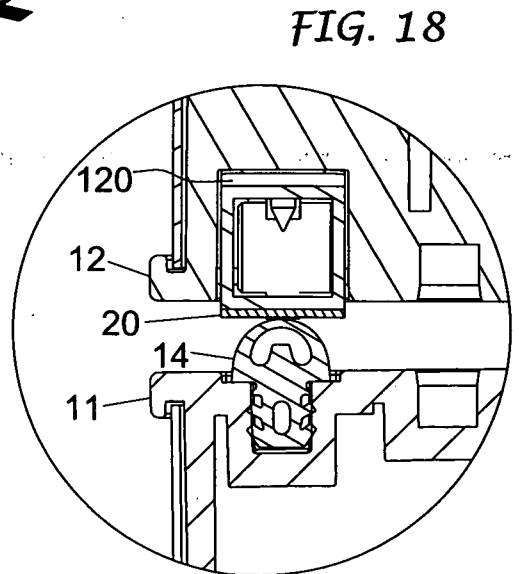

FIG. 18

## INTERNATIONAL SEARCH REPORT

International application No  
PCT/IT2010/000250A. CLASSIFICATION OF SUBJECT MATTER  
INV. B65B31/02  
ADD.

According to International Patent Classification (IPC) or to both national classification and IPC

## B. FIELDS SEARCHED

Minimum documentation searched (classification system followed by classification symbols)  
B65B

Documentation searched other than minimum documentation to the extent that such documents are included in the fields searched

Electronic data base consulted during the international search (name of data base and, where practical, search terms used)

EPO-Internal

## C. DOCUMENTS CONSIDERED TO BE RELEVANT

Category*	Citation of document, with indication, where appropriate, of the relevant passages	Relevant to claim No.
Y A	US 2005/050856 A1 (BAPTISTA ALEXANDRE A N [US]) 10 March 2005 (2005-03-10) paragraphs [0035] - [0037], [0049], [0058]; figures 4,6,7 -----	1,11-15 2-10
Y A	US 2007/204561 A1 (KAHN JORDAN A [US] ET AL KAHN JORDAN ARON [US] ET AL) 6 September 2007 (2007-09-06) paragraph [0071]; figures 2,2b, 6 -----	1,11,15 2-10
Y A	US 5 638 664 A (LEVSEN CLARK A [US] ET AL) 17 June 1997 (1997-06-17) column 4, line 59 - line 64; figures 6,7,9 column 5, line 43 - line 51 -----	12 2-10
Y A	EP 1 564 148 A (FLAEM NUOVA SPA [IT]) 17 August 2005 (2005-08-17) paragraph [0020]; figure 5 -----	13,14 2-10
	-/--	

 Further documents are listed in the continuation of Box C. See patent family annex.

\* Special categories of cited documents :

"A" document defining the general state of the art which is not considered to be of particular relevance  
 "E" earlier document but published on or after the international filing date  
 "L" document which may throw doubts on priority claim(s) or which is cited to establish the publication date of another citation or other special reason (as specified)  
 "O" document referring to an oral disclosure, use, exhibition or other means  
 "P" document published prior to the international filing date but later than the priority date claimed

"T" later document published after the international filing date or priority date and not in conflict with the application but cited to understand the principle or theory underlying the invention  
 "X" document of particular relevance; the claimed invention cannot be considered novel or cannot be considered to involve an inventive step when the document is taken alone  
 "Y" document of particular relevance; the claimed invention cannot be considered to involve an inventive step when the document is combined with one or more other such documents, such combination being obvious to a person skilled in the art.  
 "&" document member of the same patent family

Date of the actual completion of the international search

5 November 2010

Date of mailing of the international search report

16/11/2010

Name and mailing address of the ISA/  
European Patent Office, P.B. 5818 Patentlaan 2  
NL - 2280 HV Rijswijk  
Tel. (+31-70) 340-2040,  
Fax: (+31-70) 340-3016

Authorized officer

Lawder, M

## INTERNATIONAL SEARCH REPORT

International application No

PCT/IT2010/000250

C(Continuation). DOCUMENTS CONSIDERED TO BE RELEVANT		
Category*	Citation of document, with indication, where appropriate, of the relevant passages	Relevant to claim No.
A	DE 34 03 534 A1 (LAECOVAC VAKUUMTECHNIK GMBH [DE]) 8 August 1985 (1985-08-08) page 10, line 24 - line 34; figures 1,5,6 -----	1-15
A	EP 1 990 280 A (FLAEM NUOVA SPA [IT]) 12 November 2008 (2008-11-12) paragraph [0012]; figure 2 -----	1-15

# INTERNATIONAL SEARCH REPORT

Information on patent family members

International application No

PCT/IT2010/000250

Patent document cited in search report	Publication date	Publication date	Patent family member(s)	Publication date
US 2005050856	A1	10-03-2005	AU 2004215313	A1 10-09-2004
			MX PA05009126	A 20-10-2005
			US 2007113523	A1 24-05-2007
			WO 2004076284	A2 10-09-2004
US 2007204561	A1	06-09-2007	NONE	
US 5638664	A	17-06-1997	AT 213711	T 15-03-2002
			AU 6489696	A 18-02-1997
			CA 2226318	A1 06-02-1997
			CN 1191514	A 26-08-1998
			DE 69619527	D1 04-04-2002
			DE 69619527	T2 31-10-2002
			EP 0839107	A1 06-05-1998
			WO 9703881	A1 06-02-1997
EP 1564148	A	17-08-2005	AT 424348	T 15-03-2009
			ES 2322165	T3 17-06-2009
			IT BS20040009	U1 12-05-2004
			PT 1564148	E 14-05-2009
			SI 1564148	T1 31-08-2009
DE 3403534	A1	08-08-1985	NONE	
EP 1990280	A	12-11-2008	US 2008276573	A1 13-11-2008