

(No Model.)

W. P. TRACY.
BASE FOR FURNITURE.

No. 527,007.

Patented Oct. 2, 1894.

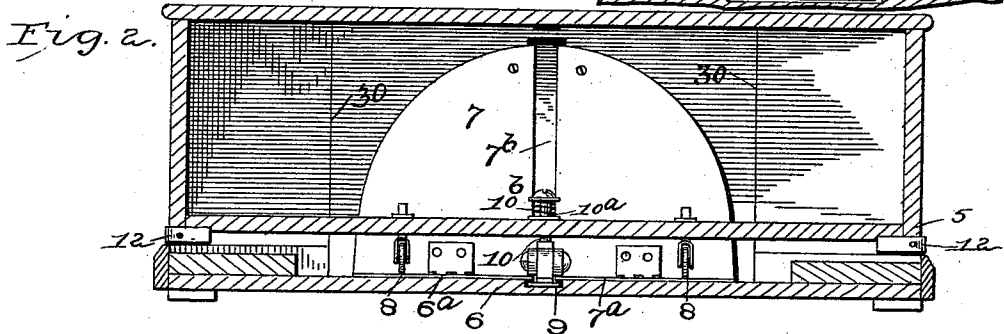
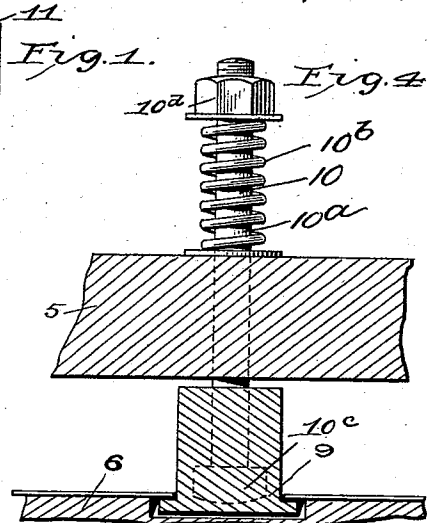
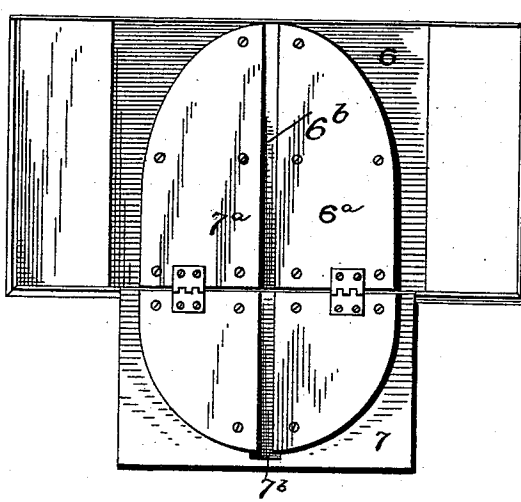
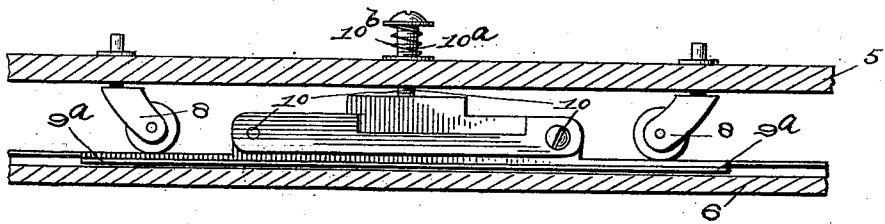

Fig. 3.



Attest
Wm. F. Hall.
[Signature]

Inventor
Wm. P. Tracy
by [Signature]
Atty.

UNITED STATES PATENT OFFICE.

WILLIAM P. TRACY, OF GRAND RAPIDS, MICHIGAN.

BASE FOR FURNITURE.

SPECIFICATION forming part of Letters Patent No. 527,007, dated October 2, 1894.

Application filed April 19, 1894. Serial No. 508,112. (No model.)

To all whom it may concern:

Be it known that I, WILLIAM P. TRACY, a citizen of the United States of America, residing at Grand Rapids, in the county of Kent and State of Michigan, have invented certain new and useful Improvements in Bases for Furniture, of which the following is a specification.

My invention relates to improvements in revolving bases for furniture and the platform therefor, and the object of the invention is to provide a revolving base mounted upon a folding platform whereby the parts when not in use may be confined to a comparatively small space, while when in use an ample platform may be provided upon which to revolve the base. I also aim to improve the base in the various details of construction looking to increased durability, efficiency and ease of operation.

The invention is illustrated in the accompanying drawings, in which—

Figure 1, is a plan view of the platform with the base removed. Fig. 2, is a longitudinal section through the platform and revolving base. Fig. 3, is a detail section from front to rear, and Fig. 4, is a detail view.

Referring more particularly to the figures, 5 represents the movable or revolving base of any desired form or construction, except as hereinafter specified, and supporting any desired article or imitation article of furniture such as a book case, wardrobe or the like combined with a folding bed or similar article. This base rests upon a platform or support, upon which it is designed to be moved or revolved. The main portion 6 of the platform is of approximately the same size as the base mounted thereon and in the normal position of the parts is designed to give the appearance of forming a part of the said base. A leaf or door 7 is centrally hinged to the front edge of the platform and normally rests in a recess or opening 30 formed in the front of the base, forming practically a part thereof and presenting a smooth and finished appearance. When the base is to be revolved, however, this leaf occupies the same plane with the platform support 6 and forms a continuation or extension thereof sufficiently

large to allow the base to be drawn out far enough for this purpose.

The base is mounted upon a series of casters 8 arranged in a circular manner and these casters travel upon bearing plates of sheet metal 6^a and 7^a, which together form a circular wear plate upon which the casters roll easily as the base is moved. A groove or way 6^b is formed in the portion 6 and the groove 7^b in the leaf forms a continuation of this groove when the leaf is down. A bar or block 9 is arranged to slide freely in this groove and to this block the base is pivotally connected by a suitable pivot pin 10. As the weight of the base is supported entirely upon the casters 8, but very little friction is encountered when the base is drawn out as the block 9 can fit with comparative looseness within the groove, and the casters will roll easily upon the metallic bearing plates. I prefer to have the pivot pin extend up through the floor of the base as shown at 10^a where it is surrounded by a coiled spring 10^b bearing against a head or nut which provides a yielding connection between the parts. Further than this the pivot pin is made in the form of a screw or bolt whereby it may be readily engaged with and disengaged from the sliding block when desired.

The casters 8 are connected to the base by swivel joints in substantially the ordinary manner and it will thus be seen that this answers the double purpose of supporting or carrying the base as it is drawn out and also as it is swung upon its pivot.

A bearing plate or ledge 11 extends across the rear edge of the platform, and is adapted to prevent backward movement of one corner of the base when the opposite corner is drawn out. By this means the base may be drawn out by simply drawing upon one end as the ledge will resist the backward movement of the opposite end until the pivot block has traveled out a distance sufficient to permit the said opposite end to swing clear of the ledge against which it bears, when the continued pressure will revolve the base to the desired extent. In order to prevent wear of the corners when they contact with the ledge they are provided with rounded bearing plates

12 which serve both to prevent wear and reduce friction. In order to provide a smooth bearing surface for the rollers the block 9 is provided with extended portions 9^a at either end which fill up the groove and present a flush surface so that when the base is revolved no resistance is encountered as they cross the groove.

Instead of having a pivot upon which the base turns in the form of a screw I may embed the head of a bolt 10^c in the block 9 or secure it thereto by any suitable means, with the body of the bolt extending up through the bottom of the base and provided with a suitable nut 10^d by which the spring may be compressed to any desired extent.

Having thus described my invention, what I claim is—

1. In combination the platform and hinged leaf, the base mounted on the platform, a rolling support between the base and platform, and a pivotal connection for the base, said pivotal connection having sliding movement from the platform forward upon the leaf, substantially as described.

2. In combination, the platform, the leaf hinged thereto, said platform and leaf having a groove or way therein, the base having a pivot sliding in said groove, and casters supporting said base, substantially as described.

3. In combination, the platform, the leaf hinged thereto, said platform and leaf having a groove or way therein, a base having a pivot provided with a sliding connection with said groove, casters supporting the base, and a

bearing ledge upon the rear of the platform adapted to contact with one of the corners of the base, substantially as described.

4. In combination, the platform having a groove or way therein, the base mounted on casters thereon and having a pivot sliding in said groove or way and the grooved leaf hinged to said platform and adapted to form a continuation thereof, said base having an opening or recess adapted to receive the leaf when the same is swung upward, substantially as described.

5. In combination, the platform, the leaf hinged thereto, said platform and leaf having a groove transversely therein, a base mounted on casters on said base, a block sliding in said groove and having pivotal connection with the base, and extensions from the ends of said block filling up said grooves and providing a flush bearing surface for the casters, substantially as described.

6. In combination with the grooved platform and leaf, the block sliding in said groove, the base and a pivotal connection between said base and block comprising the pivot pin extending through the bottom of the base, and having a spring encircling the same and exerting a downward pressure upon said bottom, substantially as described.

In testimony whereof I affix my signature in presence of two witnesses.

WILLIAM P. TRACY.

Witnesses:

JOHN VAN EWEN,
GEORGE N. DAVIS.