

(19) World Intellectual Property
Organization
International Bureau



(43) International Publication Date
1 July 2004 (01.07.2004)

PCT

(10) International Publication Number
WO 2004/054705 A1

- (51) International Patent Classification⁷: **B01J 19/12**,
H05B 6/68 (SE). FAGRELL, Magnus [SE/SE]; Nordhemsvägen 7A,
S-756 46 UPPSALA (SE).
- (21) International Application Number:
PCT/SE2003/001964 (74) Agent: DR LUDWIG BRANN PATENTBYRÅ AB; P O
Box 17192, S-104 62 STOCKHOLM (SE).
- (22) International Filing Date:
17 December 2003 (17.12.2003) (81) Designated States (national): AE, AG, AL, AM, AT, AU,
AZ, BA, BB, BG, BR, BW, BY, BZ, CA, CH, CN, CO, CR,
CU, CZ, DE, DK, DM, DZ, EC, EE, EG, ES, FI, GB, GD,
GE, GH, GM, HR, HU, ID, IL, IN, IS, JP, KE, KG, KP, KR,
KZ, LC, LK, LR, LS, LT, LU, LV, MA, MD, MG, MK, MN,
MW, MX, MZ, NI, NO, NZ, OM, PG, PH, PL, PT, RO, RU,
SC, SD, SE, SG, SK, SL, SY, TJ, TM, TN, TR, TT, TZ, UA,
UG, US, UZ, VC, VN, YU, ZA, ZM, ZW.
- (25) Filing Language: English
- (26) Publication Language: English
- (30) Priority Data:
60/433,966 18 December 2002 (18.12.2002) US
02102792.5 18 December 2002 (18.12.2002) EP
- (71) Applicant (for all designated States except US): PER-
SONAL CHEMISTRY I UPPSALA AB [SE/SE];
Kungsgatan 76, S-753 18 UPPSALA (SE). (84) Designated States (regional): ARIPO patent (BW, GH,
GM, KE, LS, MW, MZ, SD, SL, SZ, TZ, UG, ZM, ZW),
Eurasian patent (AM, AZ, BY, KG, KZ, MD, RU, TJ, TM),
European patent (AT, BE, BG, CH, CY, CZ, DE, DK, EE,
ES, FI, FR, GB, GR, HU, IE, IT, LU, MC, NL, PT, RO, SE,
SI, SK, TR), OAPI patent (BF, BJ, CF, CG, CI, CM, GA,
GN, GQ, GW, ML, MR, NE, SN, TD, TG).
- (72) Inventors; and
- (75) Inventors/Applicants (for US only): RAY, Ian, Christo-
pher [GB/SE]; Jägarbacken 5, S-182 39 DANDERYD

[Continued on next page]

(54) Title: MICROWAVE HEATING SYSTEM

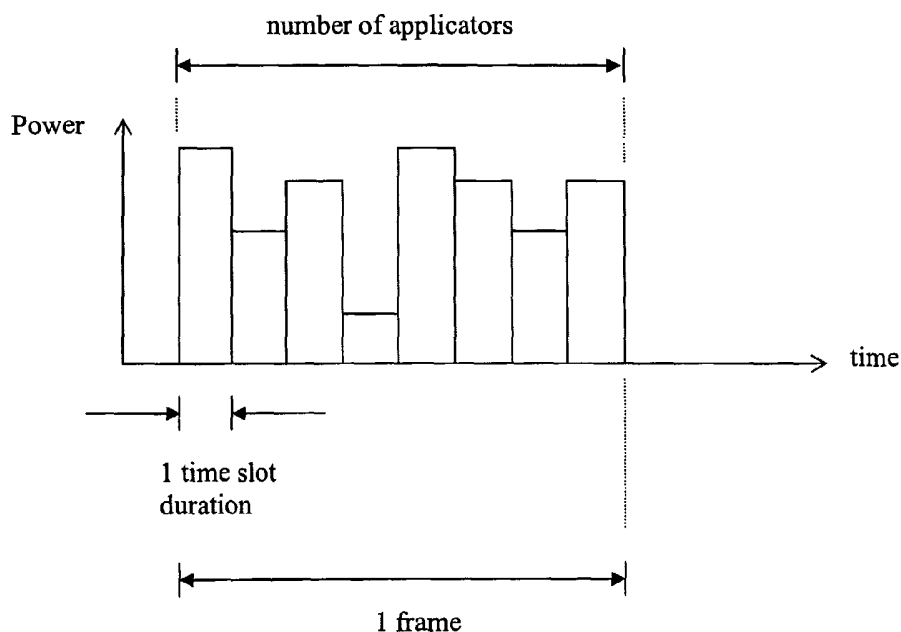

(57) Abstract: Microwave heating system comprising a plurality of microwave applicators for heating loads arranged in said applicators, a control means, one microwave generator to generate microwave energy having a controllable frequency and power level, and a microwave switch arranged to connect said microwave generator to each of said applicators. Each microwave applicator is dedicated a heating time slot in a time frame, and that said time frame comprises time slots for applicators to be heated. During microwave heating, microwave energy is applied to the microwave applicators in its respective time slot, in consecutive time frames.



WO 2004/054705 A1



Declaration under Rule 4.17:

— *of inventorship (Rule 4.17(iv)) for US only*

Published:

— *with international search report*

For two-letter codes and other abbreviations, refer to the "Guidance Notes on Codes and Abbreviations" appearing at the beginning of each regular issue of the PCT Gazette.

Title

Microwave heating system

Field of the invention

5 The present invention relates to a microwave heating system and a method in a microwave heating system according to the preambles of the independent claims.

Background of the invention

10 A microwave heating system for carrying out chemical reactions, and particularly organic synthesis reactions, is an important and well-known technique. Using microwave heating in a very special way makes it possible to increase the reaction rate of chemical reactions by orders of magnitude. The use of microwaves also often leads to higher yield and purity of the final product.

15 Microwave assisted chemistry has been used for many years. However, the apparatuses and methods have to a great extent been based upon conventional domestic microwave ovens. Domestic microwave ovens have a multimode cavity and the energy is applied at a fixed frequency at 2450 MHz. The use of single mode cavities have also been reported, see e.g. US-5,393,492 and US-4,681,740.

20 Recent developments have led towards different types of apparatuses comprising a microwave generator, a separate applicator for holding the load (or sample) to be treated, and a waveguide leading the generated microwave radiation from the generator and coupling it into the applicator.

25 When coupling electromagnetic radiation such as microwaves from a source to an applicator, it is important to match the transmission line impedance and the applicator impedance (with load) in order to achieve a good transfer of power.

30 The international patent application WO-00/36880 discloses a microwave apparatus and methods for performing chemical reactions where the apparatus applies one or more semiconductor based microwave generators making the apparatus suitable for parallel processing of chemical compound reactions. The invention disclosed in the WO-publication further relates to methods for heating

35

a plurality of samples simultaneously or sequentially, methods for monitoring a microwave heated chemical reaction, and methods where the optimum conditions with respect to parameters, such as frequency and applied power can be determined for the system consisting of the combination of apparatus and
5 chemical compound. The apparatus and method can be used to prepare a large number of compounds in a parallel process, where the compounds do not share common molecular properties. This is possible in a parallel process since the apparatus is capable of coupling the application of the electromagnetic radiation to each compound independently. However, this parallel energy application is
10 not described in detail in the WO-publication.

In US-5,796,080 a microwave apparatus for controlling power levels in individual multiple cells is disclosed. This apparatus is alleged to be useful for concurrently controlling a plurality of chemical reactions from a single
15 microwave source. The power level of the microwave energy to be applied to each sample holder is individually adjustable by dynamic mechanical moderating means arranged close to each sample holder. It is considered that one drawback with this known device is the structural complexity of e.g. the moderating means and cross-talk between the separate channels.

20 The overall object of the present invention is to achieve a microwave heating system adapted to perform parallel processing of a large number of loads in microwave applicators, where the processing of each load may be individually controlled and optimised.

25 A more specific object is to achieve an economically feasible and structurally realizable microwave heating system.

Summary of the invention

30 The above-mentioned objects are achieved by the present invention according to the independent claims.

Preferred embodiments are set forth in the dependent claims.

The microwave heating system and the method in the microwave heating system may operate simultaneously in the time domain and frequency domain. Heating of individual chemical compounds are to be performed in the frequency domain whilst the whole plurality of, for example 24 compounds, will be performed in the time domain.

Heating a compound in the frequency domain refers to tracking its resonant frequency as it warms up and possibly during its boiling.

10 The fact that one power amplifier may be shared by a plurality of applicators means that different temperatures may be controlled for many different chemical reactions in parallel. These may be time multiplexed dedicating each chemical reaction a unique time slot. It has been found by the inventors that continuous microwave heating is not necessary. A chemical reaction requires time to absorb the heat. The microwave power may be switched on and off in the form of pulses, where each pulse envelope has a varying duty cycle. In one preferred embodiment of the system the time slots are of fixed duration so the power levels can vary inside each time slot.

20 The goal of this system is to simultaneously heat as many chemical reactions as possible in the shortest period of time to the lowest cost per sample as possible.

A number of advantages of the microwave heating system according to the present invention are that the whole system will require only one power amplifier and only one microwave signal generator, and there is minimum risk of mutual coupling between the applicators due to the possibility to freely dedicate a specific applicator to a specific time slot.

30 A great benefit of a computer-controlled microwave heating system is that it can steer all individual chemical reactions independently in power, frequency and time, and it can be programmed to learn from the results of the chemical reactions in order to modify heating profiles.

Short description of the appended drawings

Figure 1 is a block diagram of the microwave heating system according to the present invention.

5 Figure 2 is a block diagram illustrating the different parts of the microwave system according to a preferred embodiment of the present invention.

Figure 3 illustrates a preferred embodiment of the power amplifier.

Figure 4 illustrates a time frame including heating time slots according to the present invention.

Figure 5 illustrates a number of time frames according to the present invention.

10 Figure 6 shows a ramping sequence of one time slot.

Figure 7 schematically illustrates a microwave heating arrangement comprising four microwave heating system as illustrated in figure 2.

Figure 8 illustrates the microwave heating system according to an alternative embodiment of the present invention.

15

Detailed description of preferred embodiments of the invention

Initially a bit more should be said here about the nature of microwave heating. Maximum power is generally only required for a small percentage of the total processing time. Another percentage of the time it will require no power at all.

20

As mentioned above, the goal of the present invention is to achieve a system adapted to heat as many individual chemical reactions as possible in the shortest period of time to the lowest cost per sample as possible. There will naturally be a compromise between total process time, number of reactions and
25 power available for heating.

25

System equations and heating profiles will determine the maximum dedicated slot time a reaction may be allowed in order for the chemical reaction to be maintained. This will naturally be dependent on the rate of microwave
30 absorption of the chemistry and heating profile parameters can be changed at any time.

30

In order to design the system hardware it will be necessary to determine how many power amplifiers will be required. In one preferred embodiment 10

channels per amplifier are arranged where the amplifier has 50 Watts output at 2.45 GHz. With 10 channels per amplifier this implies a 100ms heating slot time per channel per second. If the amplifier power level is increased more channels may be heated in parallel or the process time reduced.

- 5 Still another preferred embodiment is to arrange as few as 2 channels per power amplifier. This will naturally result in other values of the power level and time slot duration, which generally are dependent on the rate of absorption and heat retention of the chemical reaction concerned. It is worth mentioning here that heating at maximum power is only required at the beginning of the heating
- 10 cycle. As the chemical reaction approaches the desired temperature the rate of heating will normally be reduced.

The overall system will now be described with references to figure 1.

- 15 The microwave heating system comprises of a microwave system 2, microwave applicator matrix 4, a chemical compound container (vial) matrix 6, a control means 8, a graphical user interface (GUI) 10, an output device 12, e.g. a plotter, and a DC power supply 14.
- 20 The complete system may be manually or automatically driven via the graphical user interface (GUI), which will enable the user to manipulate the compound heating profiles.

- The system may be connected via a suitable communications link to other
- 25 computer processing systems in order to further enhance the parallel process.

- With references to figure 2 the microwave system 2 comprises a microwave generator 16, an attenuator means 18, a microwave power amplifier 20, a broadband tuneable filter 22, a circulator 24, a microwave switch 26 connected
- 30 to the applicators 28 in the applicator matrix 4, and a reflected power detector 30.

Above the applicator matrix sits the chemical container (vial) matrix, which inserts into the applicator matrix.

According to the present invention the multiple channels and its respective applicators will be handled in the time domain and each separate chemical reaction will be heated up in the frequency domain inside its own allocated time slot.

5

As indicated by arrows in figure 2 the control means 8 steers through a control signal interface 32 the frequency, power and timing of the microwave output power. It also monitors the individual reaction temperature sensors, monitors the pressure sensors and reads the reflected power level at the detector or any other detector in the system.

10

All units in the microwave system 2 may be bussed and driven by the control means 8. Some of the controlling signals shown in figure 2 are:

15

- control voltage for the power amplifier 20
- control voltage for the attenuator means 18
- control voltage for the microwave generator 16
- control voltage for the microwave switch 26

20

The power amplifier 20 may be mounted in a shielded frame to prevent feedback, coupling and leakage into other circuits. The whole system will be housed in an emission free RF sealed frame with an external electrical interface. The instrument will not radiate microwave or radio frequency interference into the surroundings.

25

Due to the fact that the applicators are driven time multiplexed, there is no danger of cross-talk or mutual coupling between the applicators. However, if the system should require more than one power amplifier, then the power amplifiers may need to be well shielded from each other. The control algorithm will

30

maintain that two adjacent applicators fed from different amplifiers are never serviced in the same or adjacent time slots.

Inside the microwave amplifier the final output stage power transistors may be suitably mounted so that the heat will be conducted away effectively.

There may be variants of this microwave heating instrument. The primary variant may operate between 2.0 to 3.0 GHz or, if possible due to applicator properties, the narrower ISM band 2.4 to 2.5 GHz. Other variants may operate around 900 MHz , 1300 MHz or 5,6 GHz. Each variant may require a different applicator matrix and a relevant microwave/RF power amplifier 20.

The different parts of the microwave system 2 will be further described in the following.

10

The microwave generator 16

The microwave generator 16 may comprise a frequency synthesizer, for example a phase-locked-loop voltage controlled oscillator (VCO). The desired synthesized frequency is steered by the control means via the control signal interface 32.

15

The microwave generator may generate a low output signal level, which may be normalised by a factory-trimmable attenuator. The signal generator may have good frequency stability ensuring reduced system error in resonant frequency tracking.

20 *Attenuator means 18*

This may be a low level input signal attenuator with minimum insertion loss, which is driven by a single controlling voltage in the range 0 to +5V. Microwave attenuation may be such that the final output signal level may be varied from 50 W to 500 mW (or 100 W to 1 W, respectively).

25

The purpose of the variable signal attenuator is:

1. to produce a low level microwave signal whilst searching for the resonant frequency of the chemical compound to be heated.

30

2. to produce a variable output power level during the heating process.

Microwave power amplifier 20

The amplifier consists of several gain matched transistor amplifier stages operating in a class suitable for good efficiency and linearity driven at a low supply voltage.

5

Figure 3 is a schematic block diagram of a microwave power amplifier according to a preferred embodiment. The input to the microwave power amplifier 20 is the output from the attenuator. [There are many design methods in which the final output power level may be reached, one such method is now described. The signal is first amplified by a fixed 40 dB to give an output power of 10 Watts at 10 2.45 GHz. This signal is then split by a power splitter into two equal channels of 5 W. These two channels are then amplified by 7 dB to give an output of 25 W per channel which are then combined at a hybrid power combiner to give a final output power level of 50 W]. For lower frequencies, for example 900 MHz, the 15 output power level may be 100 Watts because of the lower absorption at these lower radio frequencies. The amplifier itself will not have variable output power as this will lead to unwanted mismatch and non-linearity. Instead the input power level is varied before the power amplifier.

20 The input signal may be sufficiently clean, to be free of any spurious content and harmonics to avoid intermodulation products and generation of unwanted spurious output frequencies.

The output of the microwave power amplifier may also be sufficiently clean, to 25 have no spurious, no intermodulation products and have minimum phase noise. The overtones generated by the amplifier may be filtered away by the broadband tunable filter placed after the amplifier.

The power amplifier utilises switched microwave energy so that the power 30 transistors do not get as hot as if they were switched on continuously. Factors that influence the design of the power amplifier are among others current limiting features, temperature sensitivity and reflected power sensitivity.

Filter 22

The power amplifier may be followed by a tunable microwave broadband filter with minimum insertion loss over the whole operational frequency bandwidth. The filter is preferably a passive high power microwave tunable broadband cavity
5 filter. An extra filter may be included to give maximum attenuation at higher harmonic frequencies ensuring that the power being reflected from the applicator is in the operational frequency bandwidth and all intermodulation products are discarded.

Circulator 24

10 The microwave signal from the power amplifier will be fed to a high-power magnetic circulator 24 and then transmitted to an applicator. The reflected signal from the applicator is diverted to port three of the circulator, which will then be attenuated to fit inside the linear region of a microwave detector 30 which may be, for example, a Schottky diode detector. The converted DC signal
15 may represent the magnitude of the reflected power.

During the tuning phase (see below) the algorithm will utilise the reflected power detector signal to search for the resonant frequency of the chemical compound load, and during the heating phase (see below) to track the resonant frequency
20 which changes with heating.

Microwave Switch 26

A multi-branch microwave switch will transfer the microwave power to a selected applicator. The number of switched outputs will be decided at system design time depending on how many applicators will be serviced by one amplifier. The
25 switch may consist of, for example, pin-diodes or semiconductor relays.

Controlling software

The controlling software run by the control means may drive a closed-loop control heating algorithm and receive feedback from temperature and pressure sensors at the applicators 28 and the reflected power detector 30. It will set the
30 time slot interval, control the output power level, operate the microwave switch, and steer the frequency synthesizer (VCO).

Microwave Applicator

The present invention is generally applicable for microwave heating of a plurality of microwave applicators and is primarily directed towards the use of time frames that include a number of time slots where microwave energy is applied to the applicator dedicated to a specific time slot.

It has been found advantageous to use a specific dielectric microwave applicator having an elongated shape with an upper end and a lower end. The applicator is provided with a load chamber adapted to receive the chemical load to be heated and extending coaxially, with regard to the centre axis of the applicator, from the upper end to a predetermined distance from the lower end of the applicator. The applicator is further provided with a microwave coupling means, arranged in a lower section of the applicator, where microwave energy is fed to the applicator.

A high degree of microwave coupling into the ceramic applicator may be achieved through selection of the correct coaxial transmission line and correct impedance matching to the transmission line.

One example of microwave applicators where the present invention may be applicable is to be found in the international patent application PCT/SE02/01813 having an international filing date of October 4, 2002, by the same applicant as the present application.

DC Power unit 14

If the system will only require one power amplifier then the DC input power requirement may be less than one kilowatt and will be determined by the power amplifier efficiency.

25

The operation of the system will now be described.

Preferably the system operation will be through some graphical user interface (GUI). The system operator may control the heating profiles by setting system parameters and monitor the sensors on the applicators.

30

Figures 4 and 5 illustrate the basic principle of the present invention.

According to the present invention each microwave applicator is dedicated a heating time slot in a time frame. A time frame comprises time slots for the applicators to be heated, and during microwave heating, microwave energy is applied to the microwave applicators in its respective time slot, in consecutive
5 time frames. The microwave energy is coupled to the respective microwave applicator by the microwave switch in accordance with time slot control signals from said control means.

Within each time slot the microwave energy is optimised with regard to frequency and power level, by said control means, to the load to be heated by the
10 applicator dedicated to that time slot.

In figures 4 and 5 the different heights of the bars represent different powers in separate time slots. Preferably there may also be a number of additional redundant slots per frame so that extra time may be applied to chemical reactions at the start of the heating phase. In figure 5 is illustrated the inventive
15 optimisation; the microwave energy for the same time slot in consecutive time frames are changed (in this example the power decreases for the last time slot).

According to one preferred embodiment there may be, in each time slot, a ramp-up time, full-power time, ramp-down time (see figure 6). The whole sequence is
20 controlled by the control means.

The power ramping sequence will be as follows:

1. set the attenuator to maximum attenuation.
- 25 2. select the channel at the microwave switch.
3. select the relevant frequency at the microwave generator.
4. switch on the final transistor drain voltage for output power at minimum level.
5. ramp up the power by selecting programmed steps at the attenuator.
- 30 6. continue at the required microwave output power level for a defined time inside the time slot.
7. ramp down the output power.
8. switch off the final transistor drain voltage.
9. de-select the channel at the RF switch.

The reason for having a power ramping profile inside each time slot is to prevent amplifier overshoot and ringing, and to prevent the creation of harmonic frequencies of the switching frequency. If the switching were purely a square wave this would generate an infinite amount of harmonic frequencies of the switching frequency and a reduction of the main carrier power.

According to another embodiment of the present invention with regard to how the microwave energy is applied within each time slot, the ramp-up time and ramp-down time are made shorter and according to one extreme situation approach zero, i.e. the microwave energy more or less initially reaches its highest power level within each time slot.

According to still another embodiment the microwave energy is adjusted to a lower power level, above zero, during switching compared to the level during the rest of the time slot.

Due to the fact that abrupt high power switching may cause unwanted spurious harmonic power appropriate measures may be taken to avoid unwanted emission.

Heating Control Algorithm

The heating algorithm may preferably be divided up into two different phases, namely some resonant frequency search, followed by heating (with or without tracking the change in resonant frequency).

As an alternative the heating control algorithm may use some preset profile that includes variants of the algorithm that do not use any feedback at all and variants where some simplified feedback is used. In that special case where no feedback is used no measurements are performed during the heating phase and one preset frequency and one power setting may be used.

In the following the above-mentioned two phases of the heating control algorithm will be described.

Resonant frequency search phase

In this phase the attenuator will be set to its highest attenuation (lowest output power) and the oscillator frequency will be swept up and down once to find the resonant frequency of the chemical compound. After the resonant frequency has been determined it may be stored in a memory of the control means.

Main heating phase

In this phase the microwave heating pulses will be applied to the applicators. The closed-loop control algorithm will calculate in real time the power levels that are required in the individual time slots for each applicator. These power levels may vary over time dependent on e.g. the temperature and pressure feedback measurements.

The control algorithm will monitor the reflected power detector and steer the synthesised frequency of the microwave generator to keep the chemical reaction in resonance. This may be done by maintaining the lowest possible reflection coefficient measured at the reflected power detector. As a chemical compound heats up, its resonant frequency predominantly increases, and as it approaches its boiling point the rate of change of resonance reaches its maximum. After boiling has started the resonant frequency still continues to increase for a small duration of time but the rate of change decreases again. For some chemical compounds this rate of change of resonant frequency can be extremely fast around its boiling point whilst other chemicals are much slower. It is dependent on the Q-value of the resonant circuit of the combination of applicator plus chemical compound plus container vial. This combination presents a certain complex load impedance to the amplifier. For some chemicals there is a high Q-value of resonance whilst others are much more broad banded, depending on the dielectric properties of the compound.

Figure 7 schematically illustrates a microwave heating arrangement comprising four microwave subsystems as illustrated in figure 2. One of the subsystems is indicated by a square with dashed periphery.

In an alternative embodiment of the present invention, which is schematically illustrated in figure 9, the microwave heating system only includes a microwave generator 16', a power amplifier 20', a microwave switch 26' and at least two
5 microwave applicators 28'. This alternative embodiment may be regarded as a minimum version of a microwave heating system according to the present invention. Also included is a control means (not shown in the figure) adapted to control the microwave generator to generate microwave energy to be applied to the applicators, within time slots in time frames, and also to control the
10 microwave switch. In this embodiment it may be decided in advance that a preset level of microwave energy is applied during a predetermined time and that no feedback from the applicators is used.

The present invention also relates to the use of the microwave heating system, or
15 the microwave heating arrangement as described above, as well as the method in such a system or arrangement for performing chemical reactions and especially for organic synthesis reactions.

The present invention is not limited to the above-described preferred
20 embodiments. Various alternatives, modifications and equivalents may be used. Therefore, the above embodiments should not be taken as limiting the scope of the invention, which is defined by the appending claims.

Claims

1. Microwave heating system comprising a plurality of microwave applicators (28) for heating loads arranged in said applicators, a control means (8), one microwave generator (16) to generate microwave energy having a controllable frequency and power level, and a microwave switch (26) arranged to connect said microwave generator to each of said applicators, characterized in that each microwave applicator is dedicated a heating time slot in a time frame, and that said time frame comprises time slots for loads in applicators to be heated, wherein during microwave heating, microwave energy is applied to said microwave applicators in its respective time slot, in consecutive time frames.
2. Microwave heating system according to claim 1, characterized in that said microwave energy is coupled to the respective microwave applicator by said microwave switch in accordance with time slot control signals from said control means.
3. Microwave heating system according to claim 1, characterized in that within each time slot the microwave energy is optimised with regard to frequency and power level, by said control means, to the load to be heated by the applicator dedicated to that time slot.
4. Microwave heating system according to claim 3, characterized in that the microwave system further comprises an attenuator means (18) and a power amplifier (20), wherein said attenuator means and power amplifier are controlled by said control means in order to achieve said optimised microwave energy.
5. Microwave heating system according to claim 1, characterized in that said microwave switch is controlled by said control means to couple the microwave generator to a specified microwave applicator during the time slot dedicated to that specified microwave applicator.
6. Microwave heating system according to claim 1,

characterized in that a heating time slot has an adjustable time slot duration.

7. Microwave heating system according to claim 1,
5 characterized in that all time slots within a time frame have individually adjustable time slot durations.

8. Microwave heating system according to claim 1,
characterized in that all time slots within a time frame have the same
10 time slot duration.

9. Microwave heating system according to claim 1,
characterized in that a heating time slot is divided into a sequence of
time intervals comprising a ramp up time interval, a max output time interval
15 and a ramp down time interval.

10. Microwave heating system according to claim 1,
characterized in that said microwave applicators are arranged in a
microwave applicator matrix.

20

11. Microwave heating system according to any preceding claim,
characterized in that said load is a chemical reaction mixture.

12. Microwave heating arrangement characterized in that it
25 comprises a number of microwave heating systems according to any preceding claim.

13. Method in a microwave heating system according to any of claims 1-
11 or in a microwave heating arrangement according to claim 12 for heating
30 loads in microwave applicators by applying microwave energy to the applicators;
characterized in that the system is provided with heating time slots in
a time frame, where each time slot is dedicated to a specific microwave
applicator with a load, the method comprises the step of:

i) applying microwave energy to each applicator in each applicator's

respective time slot during consecutive time frames.

14. Method according to claim 13, characterized in that the method comprises a further step performed prior to step i):

- 5 ii) optimising the microwave energy to be applied to each microwave applicator within each applicator's respective time slot.

15. Method according to claim 14, characterized in that step ii) is performed by changing the frequency of the applied microwave energy within
10 time slot until minimum reflected energy is detected.

16. Method according to any of claims 13-15, characterized in that load is chemical reaction mixture.

15 17. Use of a microwave heating system or a microwave heating arrangement according to any of claims 1-12 for performing chemical reactions and especially for organic synthesis reactions.

18. Use of a method according to any of claims 13-16 for performing
20 chemical reactions and especially for organic synthesis reactions.

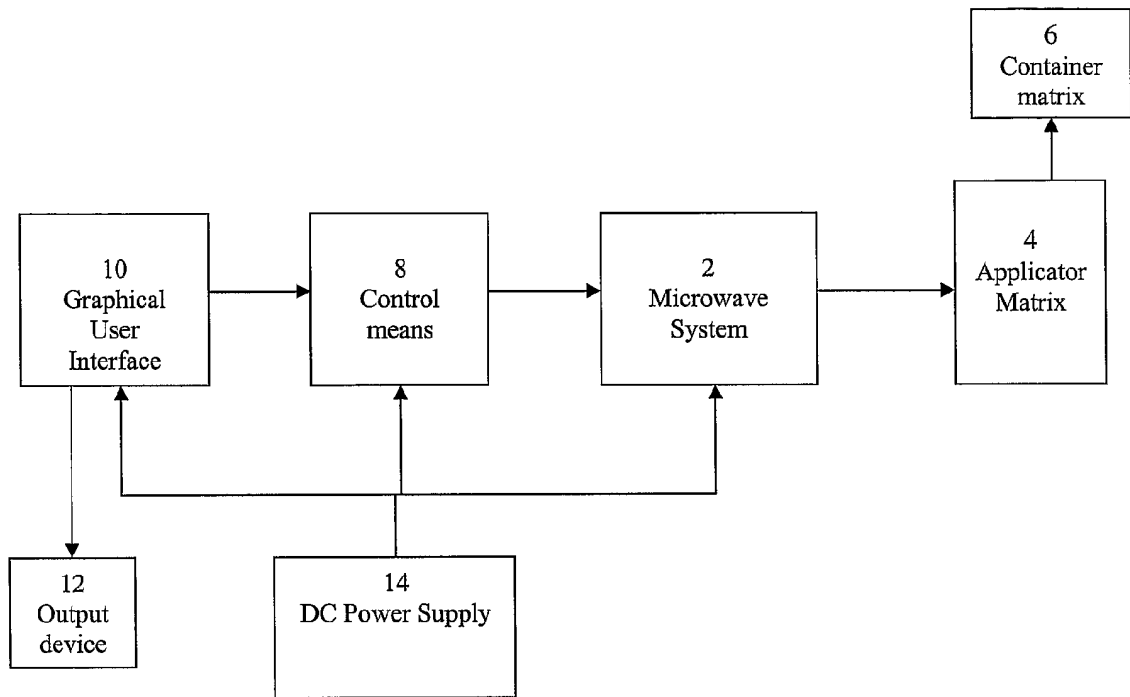

Fig. 1

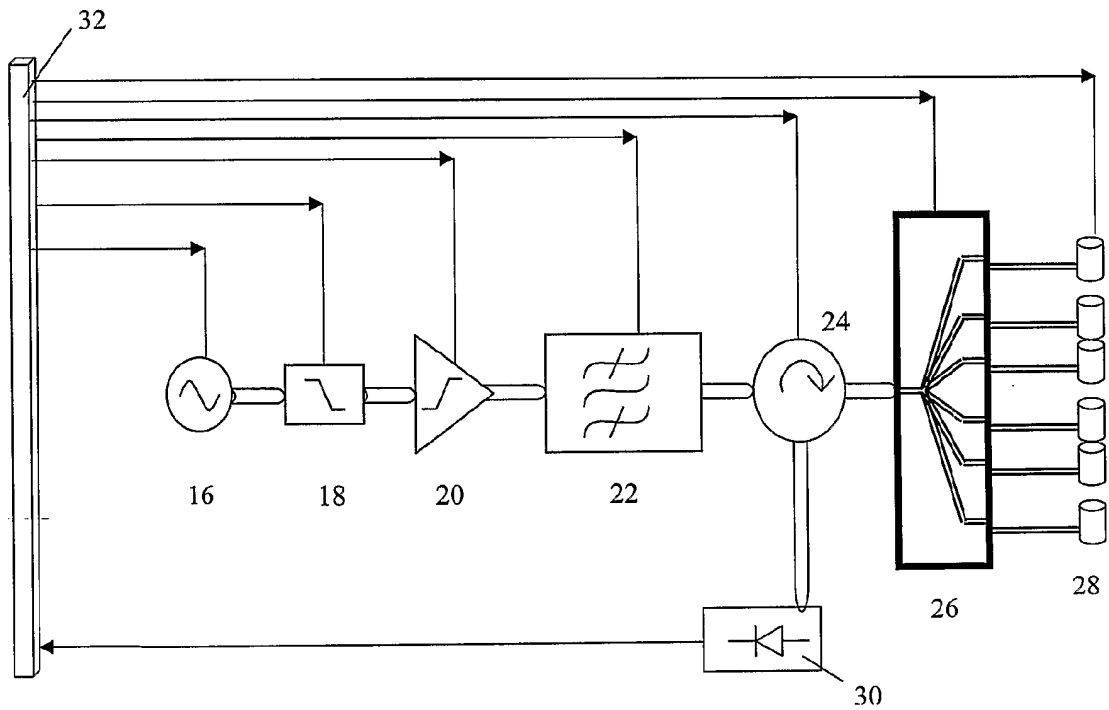

Fig. 2

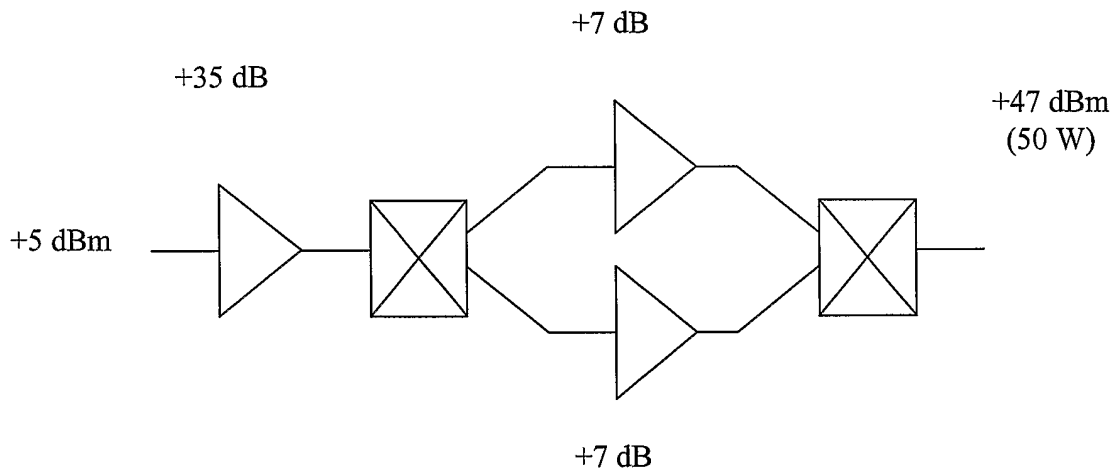

Fig. 3

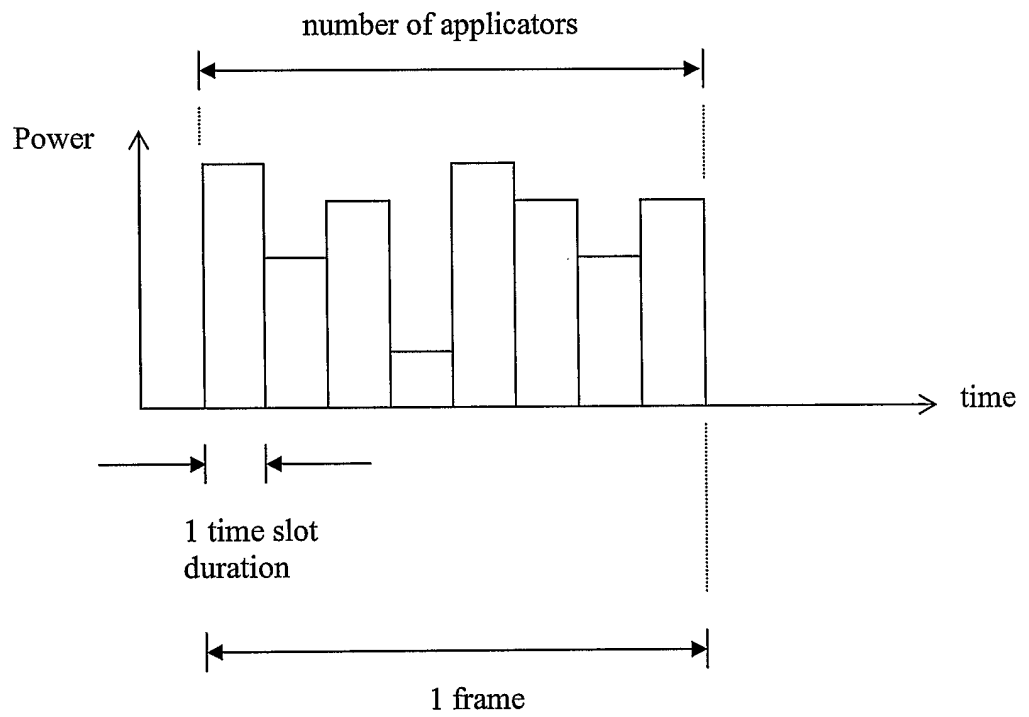

Fig. 4

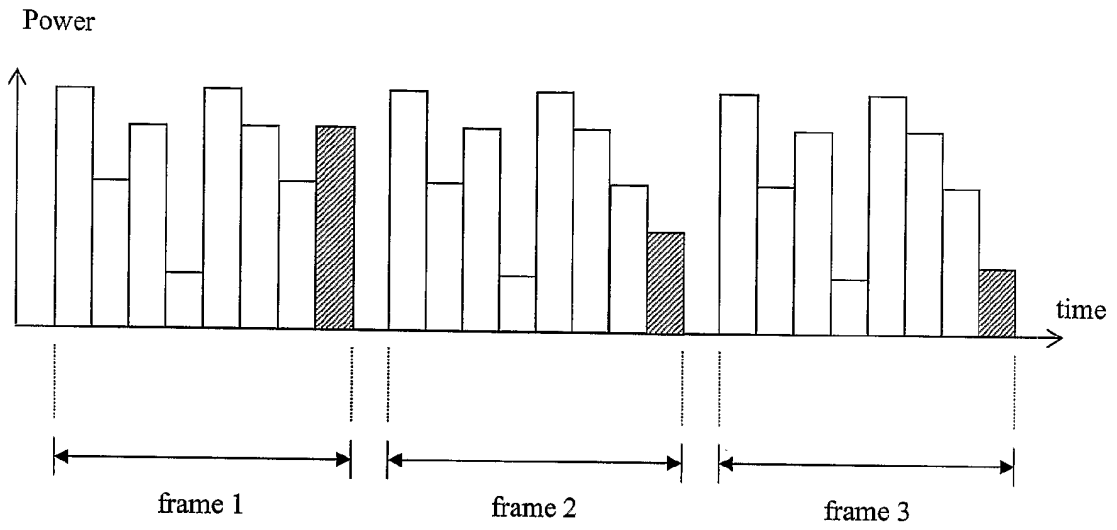

Fig. 5

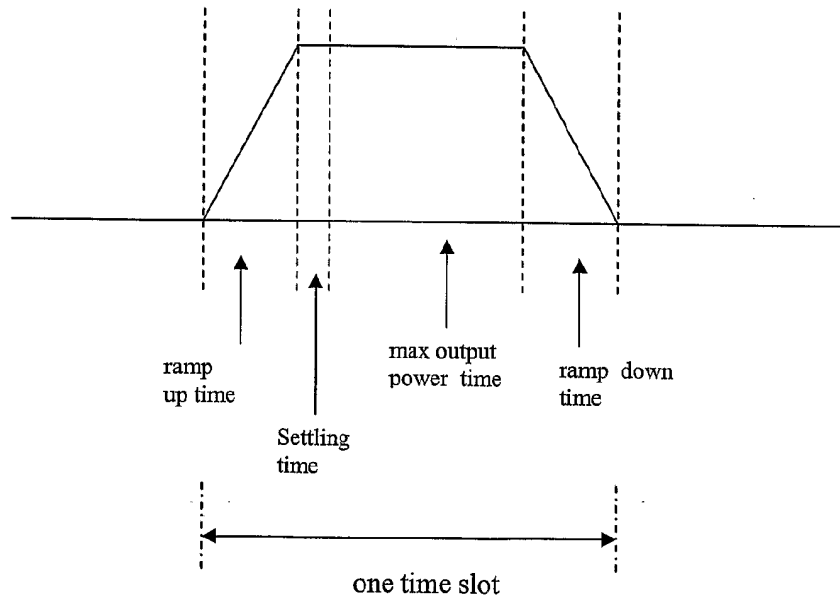

Fig. 6

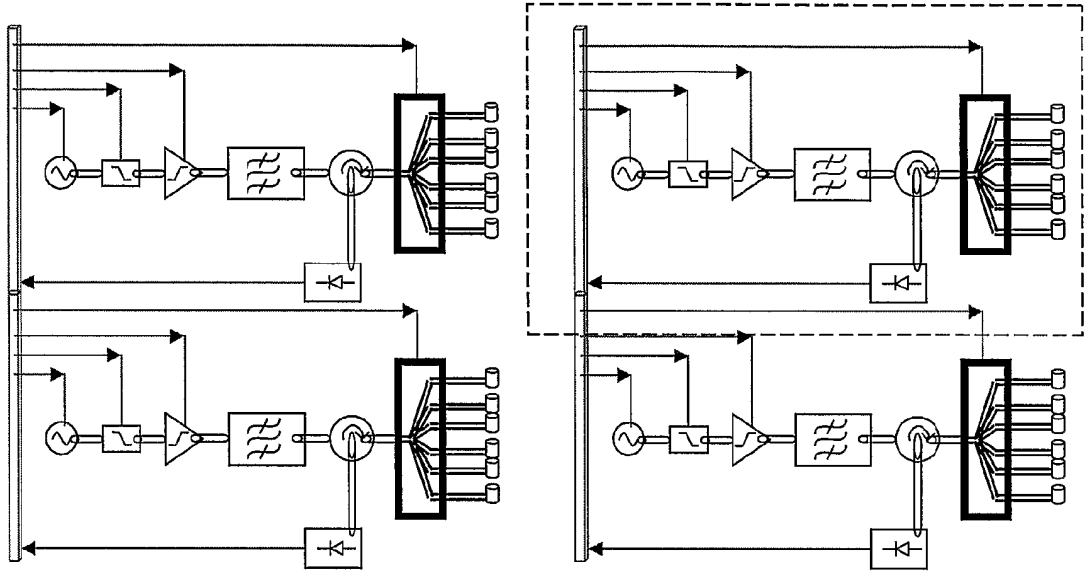

Fig. 7

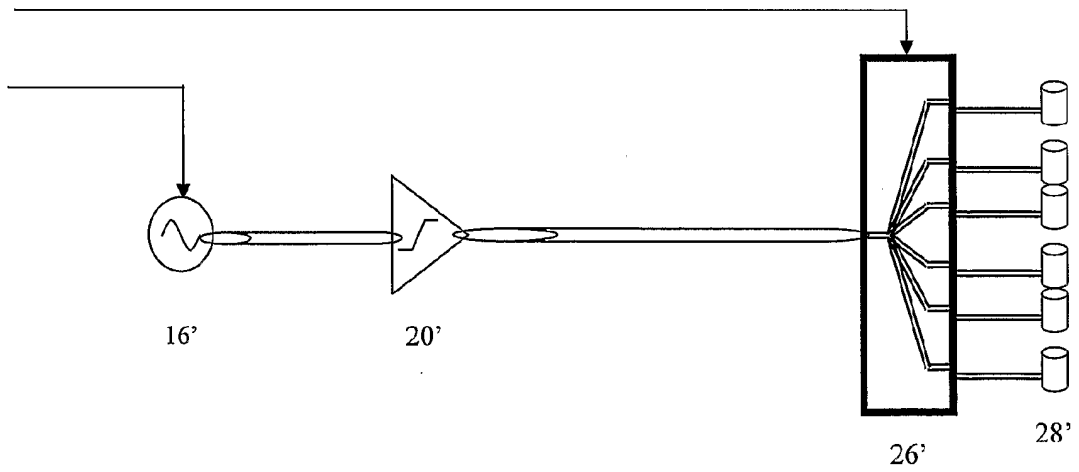

Fig. 8

INTERNATIONAL SEARCH REPORT

Internationa l application No
PCT/SE 03/01964

A. CLASSIFICATION OF SUBJECT MATTER
IPC 7 B01J19/12 H05B6/68

According to International Patent Classification (IPC) or to both national classification and IPC

B. FIELDS SEARCHED
Minimum documentation searched (classification system followed by classification symbols)
IPC 7 B01J H05B

Documentation searched other than minimum documentation to the extent that such documents are included in the fields searched

Electronic data base consulted during the international search (name of data base and, where practical, search terms used)
EPO-Internal, PAJ

C. DOCUMENTS CONSIDERED TO BE RELEVANT

Category *	Citation of document, with indication, where appropriate, of the relevant passages	Relevant to claim No.
X	US 6 403 939 B1 (FAGRELL MAGNUS) 11 June 2002 (2002-06-11) abstract column 4, line 12-19 column 4, line 39-50 column 9, line 40-48 column 10, line 7-16 column 15, line 57-59 column 18, line 61-66 figures 2,5 claims 1,5	1-3,5-8, 10-18
A	US 5 796 080 A (JENNINGS WILLIAM EDWARD ET AL) 18 August 1998 (1998-08-18) abstract figures 2,5 column 7, line 16-44 claim 1	1,12,13, 17

Further documents are listed in the continuation of box C. Patent family members are listed in annex.

* Special categories of cited documents :

<p>*A* document defining the general state of the art which is not considered to be of particular relevance</p> <p>*E* earlier document but published on or after the international filing date</p> <p>*L* document which may throw doubts on priority claim(s) or which is cited to establish the publication date of another citation or other special reason (as specified)</p> <p>*O* document referring to an oral disclosure, use, exhibition or other means</p> <p>*P* document published prior to the international filing date but later than the priority date claimed</p>	<p>*T* later document published after the international filing date or priority date and not in conflict with the application but cited to understand the principle or theory underlying the invention</p> <p>*X* document of particular relevance; the claimed invention cannot be considered novel or cannot be considered to involve an inventive step when the document is taken alone</p> <p>*Y* document of particular relevance; the claimed invention cannot be considered to involve an inventive step when the document is combined with one or more other such documents, such combination being obvious to a person skilled in the art.</p> <p>* & * document member of the same patent family</p>
--	--

Date of the actual completion of the International search <p style="text-align: center;">16 February 2004</p>	Date of mailing of the international search report <p style="text-align: center;">20/02/2004</p>
--	---

Name and mailing address of the ISA European Patent Office, P.B. 5818 Patentlaan 2 NL - 2280 HV Rijswijk Tel. (+31-70) 340-2040, Tx. 31 651 epo nl, Fax: (+31-70) 340-3016	Authorized officer <p style="text-align: center;">D/L TASSA LAFOR., J</p>
--	--

INTERNATIONAL SEARCH REPORT

Internationa	lication No
PCT/SE 03/01964	

C.(Continuation) DOCUMENTS CONSIDERED TO BE RELEVANT		
Category °	Citation of document, with indication, where appropriate, of the relevant passages	Relevant to claim No.
A	PATENT ABSTRACTS OF JAPAN vol. 011, no. 294 (E-544), 22 September 1987 (1987-09-22) & JP 62 093937 A (HITACHI LTD), 30 April 1987 (1987-04-30) abstract <p style="text-align: center;">-----</p>	1,12,13, 17

INTERNATIONAL SEARCH REPORT

Information on patent family members

Internal Application No

PCT/SE 03/01964

Patent document cited in search report		Publication date	Patent family member(s)	Publication date
US 6403939	B1	11-06-2002	AU 767644 B2	20-11-2003
			AU 1580700 A	03-07-2000
			CA 2353899 A1	22-06-2000
			CN 1335043 T	06-02-2002
			EP 1151638 A2	07-11-2001
			WO 0036880 A2	22-06-2000
			JP 2002532239 T	02-10-2002
			US 2002175163 A1	28-11-2002
			US 5796080	A
AU 7107996 A	28-04-1997			
CA 2233715 A1	10-04-1997			
DE 69626655 D1	17-04-2003			
DE 69626655 T2	18-12-2003			
EP 0853759 A1	22-07-1998			
JP 2000500061 T	11-01-2000			
WO 9713136 A1	10-04-1997			
JP 62093937	A	30-04-1987		
			JP 5013375 B	22-02-1993