



- (51) International Patent Classification: Not classified
- (21) International Application Number: PCT/IB2012/051740
- (22) International Filing Date: 10 April 2012 (10.04.2012)
- (25) Filing Language: English
- (26) Publication Language: English
- (30) Priority Data: 212303 13 April 2011 (13.04.2011) IL
- (71) Applicant (for all designated States except US): **MAGEN ECO-ENERGY (A.C.S.) LTD.** [IL/IL]; Kibbutz Magen, 85465 DN Negev (IL).
- (72) Inventors; and
- (75) Inventors/Applicants (for US only): **LEWIN, Itai** [IL/IL]; Kibbutz Magen, 85465 DN Negev (IL). **PLASCHKES, Michael** [IL/IL]; Kibbutz Magen, 85465 DN Negev (IL).
- (74) Agents: **A.C. ENTIS-IP LTD** et al.; Raoul Wallenberg 6, 69719 Tel Aviv (IL).

- (81) Designated States (unless otherwise indicated, for every kind of national protection available): AE, AG, AL, AM, AO, AT, AU, AZ, BA, BB, BG, BH, BR, BW, BY, BZ, CA, CH, CL, CN, CO, CR, CU, CZ, DE, DK, DM, DO, DZ, EC, EE, EG, ES, FI, GB, GD, GE, GH, GM, GT, HN, HR, HU, ID, IL, IN, IS, JP, KE, KG, KM, KN, KP, KR, KZ, LA, LC, LK, LR, LS, LT, LU, LY, MA, MD, ME, MG, MK, MN, MW, MX, MY, MZ, NA, NG, NI, NO, NZ, OM, PE, PG, PH, PL, PT, QA, RO, RS, RU, RW, SC, SD, SE, SG, SK, SL, SM, ST, SV, SY, TH, TJ, TM, TN, TR, TT, TZ, UA, UG, US, UZ, VC, VN, ZA, ZM, ZW.
- (84) Designated States (unless otherwise indicated, for every kind of regional protection available): ARIPO (BW, GH, GM, KE, LR, LS, MW, MZ, NA, RW, SD, SL, SZ, TZ, UG, ZM, ZW), Eurasian (AM, AZ, BY, KG, KZ, MD, RU, TJ, TM), European (AL, AT, BE, BG, CH, CY, CZ, DE, DK, EE, ES, FI, FR, GB, GR, HR, HU, IE, IS, IT, LT, LU, LV, MC, MK, MT, NL, NO, PL, PT, RO, RS, SE, SI, SK, SM, TR), OAPI (BF, BJ, CF, CG, CI, CM, GA, GN, GQ, GW, ML, MR, NE, SN, TD, TG).

Published:

— without international search report and to be republished upon receipt of that report (Rule 48.2(g))

(54) Title: SOLAR COLLECTOR

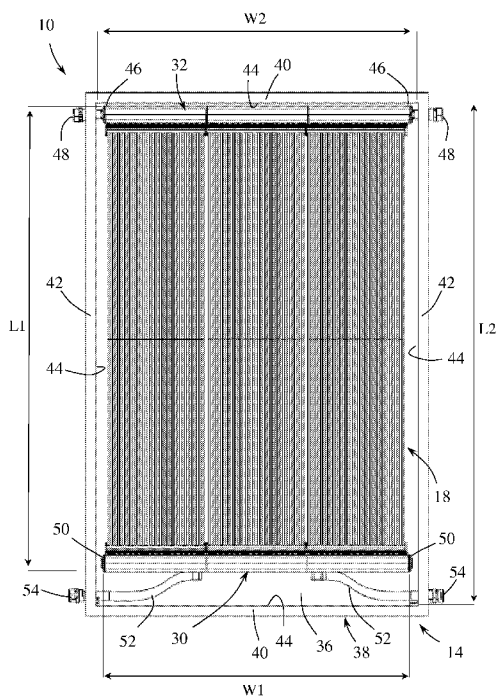

Fig. 3

(57) Abstract: A solar collector has a housing and an effective absorbing zone within the housing. The housing has a shape of a closed box and includes a receiving member and an at least partially transparent cover. Solar energy enters the housing via the cover to heat fluid within the effective absorbing zone, and the effective absorbing zone has an inlet manifold, a spaced apart outlet manifold and a plurality of plastic tubes that extend between the manifolds. One of the manifolds is rigidly fixed to the housing and the other manifold is flexibly fixed to the housing via at least one flexible joint.

WO 2012/140565 A2

SOLAR COLLECTOR

TECHNICAL FIELD

[001] Embodiments of the present invention relate to solar collectors and in particular to solar collectors with spaced manifolds and a plurality of tubes connected to and extending between the manifolds.

5

BACKGROUND

[002] Such solar collectors may include an enclosure that encloses the tubes for increasing solar energy absorption and/or for preventing the convection of heat from its structure by the surrounding atmosphere. Solar energy that enters the enclosure heats fluid circulating through the tubing and thermal changes occurring within the enclosure may cause the tubes to expand and contract.

10

[003] PCT Patent publication No. 2008000281 describes a solar collector that has an absorber and cooling conduits that are associated with the absorber. Terminal portions of the conduits are connected to a structure of the collector, with some of the terminal portions being shaped to compensate for different thermal expansions of the conduits.

15

[004] European patent publication No. 0542101 describes a solar collector with a housing and an absorber pipe that is connected to distributor lines via supply lines and removal lines which extend through openings in the housing. In order to reduce mechanical stress on the supply lines and removal lines due to thermal changes and each supply line or removal line has at least one bend that improves its elasticity.

20

SUMMARY

[005] The following embodiments and aspects thereof are described and illustrated in conjunction with systems, tools and methods which are meant to be exemplary and illustrative, not limiting in scope.

5 [006] In an embodiment of the present invention there is provided a solar collector comprising a housing and an effective absorbing zone located within the housing, the housing being of closed box-like shape and constituted by an assembly of a receiving member and an at least partially transparent cover, solar energy entering the housing via the cover being adapted to heat fluid circulating within the
10 effective absorbing zone, and the effective absorbing zone comprises an inlet manifold for receiving fluid entering the solar collector, a spaced apart outlet manifold for communicating fluid out of the solar collector and the two spaced-apart manifolds being interconnected by a plurality of plastic tubes, wherein one of the manifolds is rigidly fixed to the housing and the other manifold is flexibly fixed to
15 the housing via at least one flexible joint.

[007] Optionally, the plastic tubes extending between the manifolds extend alongside an axis, and the flexible joint extends transverse to the axis and is adapted to deform in directions both along the axis and perpendicular to the axis to compensate for thermal deformations occurring within the solar collector.

20 [008] If desired, during use of the solar collector the inlet manifold is adapted to be located below the outlet manifold so that fluid circulation from the inlet manifold towards the outlet manifold is caused at least in part by a thermo siphon circulation affect that urges warmer fluid to rise upwards.

[009] Typically, the effective absorbing zone is formed from a plurality of
25 modular units, each modular unit comprising an inlet sub-manifold for receiving fluid entering the modular unit, a spaced apart outlet sub-manifold for communicating fluid out of the modular unit and the two spaced-apart sub-manifolds being interconnected by some of the a plastic tubes of the solar collector, inlet sub-manifolds of adjacent modular units being attached to each other to form

the inlet manifold of the solar collector, and outlet sub-manifolds of adjacent modular units being attached to each other to form the outlet manifold of the solar collector.

[010] Preferably, the receiving member of the housing comprises a peripheral side wall that surrounds the effective absorbing zone; the peripheral side wall comprises a pair of horizontal edges, a pair of vertical edges and an inner face on each edge faces into the space where the effective absorbing zone is located; a first one of the horizontal edges extends alongside the inlet manifold, a second one of the horizontal edges extends alongside the outlet manifold and the vertical edges extend between the horizontal edges on opposing sides of the effective absorbing zone.

[011] Typically, the effective absorbing zone has dimensions $W1$ and $L1$ and the peripheral side wall has dimensions $W2$ and $L2$; $W1$ being defined by the length of the inlet or outlet manifolds, $L1$ being measured along the axis between the inlet and outlet manifolds, $W2$ being measured between the inner faces of opposing vertical edges, and $L2$ being measured between the inner faces of opposing horizontal edges, wherein $L1$ is smaller than $L2$ and $W1$ is smaller than $W2$.

[012] Optionally, the ratio of $L1$ to $L2$ lies substantially between 0.90 and 0.98 when measured in normal room temperature of between 20 and 29 degrees Celsius.

[013] Further optionally, the ratio of $W1$ to $W2$ lies substantially between 0.90 and 0.98 when measured in normal room temperature of between 20 and 29 degrees Celsius.

[014] Preferably, the ratio of $L1$ to $L2$ lies substantially between 0.94 and 0.96 when measured in normal room temperature of between 20 and 29 degrees Celsius.

[015] Preferably, the ratio of $W1$ to $W2$ lies substantially between 0.92 and 0.94 when measured in normal room temperature of between 20 and 29 degrees Celsius.

[016] If desired, the manifold that is flexibly fixed to the housing is the inlet manifold through which fluid enters the solar collector, the inlet manifold extending between two ends and the at least one flexible joint communicates with the inlet manifold at a location along the manifold that is spaced from the ends.

[017] Optionally, the effective absorbing zone is formed from a plurality of modular units, each modular unit comprising an inlet sub-manifold for receiving fluid entering the modular unit, a spaced apart outlet sub-manifold for communicating fluid out of the modular unit and the two spaced-apart sub-manifolds being interconnected by some of the plastic tubes of the solar collector, inlet sub-manifolds of adjacent modular units being attached to each other to form the inlet manifold of the solar collector, and outlet sub-manifolds of adjacent modular units being attached to each other to form the outlet manifold of the solar collector, wherein the at least one flexible joint communicates with the inlet manifold adjacent a location where two inlet sub-manifolds that form the inlet manifold adjoin.

[018] Typically, the solar collector comprises a pair of inlet ports and a pair of outlet ports formed on the peripheral side wall of the housing, the inlet ports being located on opposing vertical edges of the housing adjacent the inlet manifold and the outlet ports being located on opposing vertical edges of the housing adjacent the outlet manifold.

[019] Optionally, an absorption zone for solar energy comprises first and second solar collectors in accordance with the present invention, a given vertical edge of the first solar collector being positioned adjacent and alongside a given vertical edge of the second solar collector with the cover of both solar collectors facing the same direction, wherein the inlet port on the given vertical edge of the first solar collector is in fluid communication with the inlet port on the given vertical edge of the second solar collector and the outlet port on the given vertical edge of the first solar collector is in fluid communication with the outlet port on the given vertical edge of the second solar collector.

[020] In addition to the exemplary aspects and embodiments described above, further aspects and embodiments will become apparent by reference to the figures and by study of the following detailed descriptions.

BRIEF DESCRIPTION OF THE FIGURES

[021] Exemplary embodiments are illustrated in referenced figures. It is intended that the embodiments and figures disclosed herein are to be considered illustrative, rather than restrictive. The invention, however, both as to organization and method of operation, together with objects, features, and advantages thereof, may best be understood by reference to the following detailed description when read with the accompanying figures, in which:

[022] **Fig. 1A** schematically shows a perspective view of a solar collector in accordance with an embodiment of the present invention;

[023] **Fig. 1B** schematically shows the solar collector of Fig. 1 with its cover removed;

[024] **Fig. 2** schematically shows a plan view of two such solar collectors coupled to each other, each with its cover removed; and

[025] **Fig. 3** schematically shows an enlarged plan view of the solar collector with its cover removed.

[026] It will be appreciated that for simplicity and clarity of illustration, elements shown in the figures have not necessarily been drawn to scale. For example, the dimensions of some of the elements may be exaggerated relative to other elements for clarity. Further, where considered appropriate, reference numerals may be repeated within the figures to indicate like elements.

DETAILED DESCRIPTION

[027] Attention is first drawn to Figs. 1A and 1B. A solar collector 10 in accordance with an embodiment of the present invention has a closed box like housing that includes a receiving member 14 and a transparent cover 16. The solar collector 10 has within the housing an effective plastic absorbing zone 18 that absorbs solar energy entering the collector 10 via the cover 16. The effective absorbing zone 18 is optionally made of a heat stabilized polymer such as: Polypropylene, Polyolefin, Polyphenylene Sulfide (PPS) or polyethersulfone plastic

(PES); and the solar energy that enters the housing heats fluid such as water that circulates within the effective absorbing zone 18. The receiving member 14 can be made of plastic, metal or any other material that may be required for the application in which it is used.

5 [028] In an embodiment, the effective absorbing zone 18 is formed of a plurality of modular units 20. Each modular unit 20 includes a first sub-manifold 22, a second sub-manifold 24 that is axially spaced apart from the first sub-manifold 22, and a plurality of tubes 26 that extend between the first and second sub-manifolds 22, 24 along an axis X. Each first or second sub-manifold 22, 24 extends
10 between two ends 28 and has a hollow interior that opens out at these ends 28. To form the effective absorbing zone 18, the first sub-manifolds 22 of adjacent modular units 20 are attached to each other at their ends 28 to form a first manifold 30 of the solar collector 10, and the second sub-manifolds 24 of adjacent modular units 20 are attached to each other at their ends 28 to form a second manifold 32 of the solar
15 collector 10.

[029] The first and second manifolds 30, 32 of the solar collector 10 include joins at each location where two adjacent sub-manifolds 22, 24 adjoin at their ends 28. These joins that may be in the form of flanges that are located between the ends 28 of the adjacent adjoining sub-manifolds 22, 24 that meet, may act as structures
20 that strengthen the manifolds 30, 32 and increase their ability to withstand stress and resist deformation due to thermal changes occurring within the solar collector 10. It is noted however that in some embodiments of the invention the effective absorbing zone 18 can also be formed from a first manifold 30 and a second manifold 32 that were not formed from separately molded sub-manifolds (not shown).

25 [030] It should be noted that directional terms appearing throughout the specification and claims, e.g. "in", "out", "up", "down" etc., (and derivatives thereof) are for illustrative purposes only, and are not intended to limit the scope of the appended claims. In addition it is noted that the directional terms "down", "below" and "lower" (and derivatives thereof) define identical directions.

[031] Attention is additionally drawn to Fig. 3. The receiving member 14 has a floor 36 and a peripheral side wall 38 that rises above the floor 36 and surrounds an inner space where the effective absorbing zone 18 of the solar collector 10 is located. The peripheral side wall 38 has a pair of horizontal edges 40 and a pair of vertical edges 42; and an inner face 44 on each edge 40, 42 faces into the space where the effective absorbing zone 18 is located. A first one of the horizontal edges 40 extends alongside the first manifold 30, a second one of the horizontal edges 40 extends alongside the second manifold 32 and the vertical edges 42 extend axially between the horizontal edges 40 on opposing sides of the effective absorbing zone 18. The effective absorbing zone 18 has a width $W1$ that corresponds to the length of the first or second manifolds 30, 32, and a length $L1$ that is measured between the first and second manifolds 30, 32. The receiving member 14 on the other hand has a width $W2$ measured between the inner faces 44 of its vertical edges 42, and a length $L2$ measured between the inner faces 44 of its horizontal edges 40.

[032] The second manifold 32 extends between two ends 46 and is rigidly fixed adjacent each end 46 via a merge to an adjacent vertical edge 42 of the peripheral side wall 38. The second manifold 32 is also in fluid communication via the merges with secondary ports 48 that are respectively fixed to outer faces of opposing vertical edges 42. The first manifold 30 extends between two closed ends 50 and is flexibly fixed via flexible joints 52 to the vertical edges 42. Each flexible joint 52 extends transverse to the axis X between a location along the first manifold 30 that is spaced from each given one of its ends 50 to the vertical edge 42 that is adjacent that given end 50. The flexible joints 52 also provide fluid communication between the first manifold 30 and primary ports 54 that are respectively fixed to outer faces of opposing vertical edges 42.

[033] These flexible joints 52 may optionally be in the form of flexible pipes that provide each fluid communication between the port 54 they are connected to and the first manifold 30. In embodiments where the effective absorbing zone 18 is formed of modular units 20, the flexible joints 52 communicate with the first

manifold 30 at (or close to) the location where two adjacent adjoining first sub-manifolds 22 that form the first manifold 30 meet (best indicated in Fig. 1B).

[034] During use the solar collector 10 may be positioned with one of its manifolds located below its other manifold so that the solar collector 10 may utilize a thermo siphon circulation affect that urges warmer fluid to rise upwardly and thereby circulate though the effective absorbing zone 18. In the embodiments shown in these figures, the first manifold 30 is located below the second manifold 32 and thereby functions as an inlet manifold through which fluid enters the solar collector 10. From there fluid rises upwards towards the second manifold 32 that functions as an outlet manifold. The fluid that exits the second manifold 32 as warmer fluid can flow onwards to an optional storage tank (not shown) and from there the fluid may circulate back via the first manifold 30 into the effective absorbing zone 18. Optionally the storage tank is located above the upper manifold of the solar collector 10 (that in this example is the second manifold 32) for the thermo siphon circulation affect to solely cause the circulation of fluid within the solar collector 10. In some cases, a mechanical pump (not shown) may be used to circulate the fluid in the solar collector 10 alone or in conjunction with the thermo siphon circulation affect.

[035] It is noted however that the solar collector 10 can also be used when positioned with its second manifold 32 functioning as an inlet manifold that is located below its first manifold 30 that then functions as an outlet manifold. Fluid in this case that enters the second manifold 32 will rise upwards towards the first manifold 30 and then exit the solar collector 30 as warmer fluid via at least one of the primary outlets 54. In some embodiments the solar collector 10 can also be used when positioned flat with both manifolds 30, 32 at substantially the same height and then either one of the manifolds 30, 32 can be used as the inlet manifold with the other one used as the outlet manifold. In theses embodiments driving means such as a mechanical pump can be used to urge the circulation of fluid within the solar collector 10.

[036] In embodiments where the first manifold 30 acts as the inlet manifold through which fluid enters the solar collector, the entry of such fluid via the flexible joints 52 into the first manifold 30 at a location that is distal to its ends 50 (and relatively close to its center) may contribute to the even distribution of fluid along the length of the first manifold 30. Such even distribution of fluid along the first manifold 30 may contribute to the uniform distributing of fluid exiting the first manifold 30 onwards into the tubes 26 that extend towards the second manifold 32 and thereby to an improved efficiency of the solar collector 10.

[037] During use, the solar collector 10 can be exposed to environmental conditions that may vary between extreme cold conditions such as at night time and extreme hot conditions such as at midday. These varying thermal conditions that may for example be between minus 15 degrees Celsius and plus 100 degrees Celsius, may cause deformations in the solar collector 10 specifically within the effective absorbing zone 18 that is made of plastic material. The flexible joints 52 in the solar collector 10 may form an embodiment of a mechanism that can flex and absorb these deformations. Such varying thermal conditions may cause the tubes 26 extending between the manifolds 30, 32 to expand or contract in a direction along the axis X and/or may cause the first and second manifolds 30, 32 to expand or contract in a direction along their lengths which is perpendicular to the axis X. The second manifold 32 is rigidly fixed in place within the housing and thereby these deformations in the effective absorbing zone 18 may urge the first manifold 30 to move while remaining flexibly fixed and in fluid communication with the primary ports 54 in the housing via the flexible joints 52.

[038] In an embodiment, the solar collector 10 is designed to take into consideration these deformations and limit or avoid contact between the effective absorbing zone 18 and the peripheral side wall 38 of the housing during deformations that may occur within the solar collector 10. If for example the effective absorbing zone 18 were to contact and bear against the peripheral side wall 38 of the housing during expansion it could cause damage to the housing and/or to

itself over time. The solar collector 10 on the other hand is designed to also have a maximal possible heat absorbing efficiency that is defined according to the ratio between the area of the effective absorbing zone 18 and the area within the housing that is bound by the peripheral side wall 38.

5 [039] It has been found by the inventors that with the construction of the solar collector 10 in accordance with the present invention and with the dimensions L1 and W1 relative to the dimensions L2 and W2 lying within the ranges specified below, the performance of the solar collector 10 when considered in terms of its heat absorbing efficiency and its ability to avoid or limit undesired deformations due to
10 varying thermal conditions, is significantly increased as compared with hitherto known solar collectors.

[040] Thus, such significantly increased performance of a solar collector 10 has been found by the inventors to occur where the ratio of L1 to L2 lies substantially between 0.90 and 0.98 and more preferably between 0.94 and 0.96, and the ratio of
15 W1 to W2 lies substantially between 0.90 and 0.98 and more preferably between 0.92 and 0.94; when measured in normal room temperature of between 20 and 29 degrees Celsius.

[041] By way of a non binding numerical example, a solar collector 10 in accordance with an embodiment of the present invention may have an effective
20 absorbing zone 18 of width W1 equal to 0.91 meters and length L1 equal to 2 meters and the peripheral side wall 38 of the housing may have a width of W2 equal to 0.97 meters and a length L2 equal to 2.12 meters; when measured in normal room temperature of between 20 and 29 degrees Celsius.

[042] Attention is drawn to Fig. 2. To increase absorption of solar energy,
25 several solar collectors 10 can be located adjacent each other to form an absorption zone for solar energy. In the example shown, two solar collectors 10 are placed adjacent each other with adjacent primary and secondary ports 54, 48 of the collectors 10 being connected in fluid communication to each other. Fluid that circulates through these two collectors 10 first enters the right solar collector 10 at

its right primary port 54 and then flows via the right flexible joint 52 into the first manifold 30 of the right solar collector 10. From there the fluid flows out of this first manifold 30 via its left flexible joint 52 to the left primary port 54 and from there into the left solar collector 10 via its right primary port 54.

5 [043] The fluid then flows via the right flexible joint 52 of the left solar collector 10 into the first manifold 30 of the left solar collector 10. After filling the first manifolds 30 in both solar collectors 10, the fluid flows via the tubes 26 where it is heated by solar energy that enters the collectors 10. This warmer fluid enters the second manifolds 32 in both collectors 10 and then circulates out of the
10 collectors 10 via the left secondary port 48 in the left solar collector 10. The fluid may then flow on to the optional storage tank (not shown) and then circulate optionally back to the right primary port 54 of the right solar collector 10 and so on.

[044] Thus in accordance with an aspect of the present invention, the ports 54, 48 that on the one hand communicate with the deformable absorbing zone 18 while
15 remaining fixed to the housing; provide an interface via which adjacent solar collectors 10 can be easily and reliably connected to each other to form larger absorption zones for solar energy. If the ports 54, 48 were to deform together with the effective absorbing zone 18 then the connection between such adjacent solar collectors 10 could require for example additional means that can compensate for
20 such deformations. These means may be for example additional piping that can deform and thereby compensate for such deformations.

[045] In the description and claims of the present application, each of the verbs, “comprise” “include” and “have”, and conjugates thereof, are used to indicate that
25 the object or objects of the verb are not necessarily a complete listing of members, components, elements or parts of the subject or subjects of the verb.

[046] Although the present embodiments have been described to a certain degree of particularity, it should be understood that various alterations and modifications could be made without departing from the scope of the invention as hereinafter claimed.

CLAIMS:

1. A solar collector comprising a housing and an effective absorbing zone located within the housing, the housing being of closed box-like shape and constituted by an assembly of a receiving member and an at least partially transparent cover, solar energy entering the housing via the cover being adapted to heat fluid circulating within the effective absorbing zone, and the effective absorbing zone comprises an inlet manifold for receiving fluid entering the solar collector, a spaced apart outlet manifold for communicating fluid out of the solar collector and the two spaced-apart manifolds being interconnected by a plurality of plastic tubes, wherein one of the manifolds is rigidly fixed to the housing and the other manifold is flexibly fixed to the housing via at least one flexible joint.
2. The solar collector according to claim 1, wherein the plastic tubes extending between the manifolds extend alongside an axis, and the flexible joint extends transverse to the axis and is adapted to deform in directions both along the axis and perpendicular to the axis to compensate for thermal deformations occurring within the solar collector.
3. The solar collector according to claim 2, wherein during use of the solar collector the inlet manifold is adapted to be located below the outlet manifold so that fluid circulation from the inlet manifold towards the outlet manifold is caused at least in part by a thermo siphon circulation affect that urges warmer fluid to rise upwards.
4. The solar collector according to claim 3, wherein the effective absorbing zone is formed from a plurality of modular units, each modular unit comprising an inlet sub-manifold for receiving fluid entering the modular unit, a spaced apart outlet sub-manifold for communicating fluid out of the modular unit and the two spaced-apart sub-manifolds being interconnected by some of the a plastic tubes of the solar collector, inlet sub-manifolds of adjacent modular units being attached to each other to form the inlet manifold of the solar collector, and outlet sub-manifolds

of adjacent modular units being attached to each other to form the outlet manifold of the solar collector.

5 **5.** The solar collector according to claims 3 or 4, wherein the receiving member of the housing comprises a peripheral side wall that surrounds the effective absorbing zone; the peripheral side wall comprises a pair of horizontal edges, a pair of vertical edges and an inner face on each edge faces into the space where the effective absorbing zone is located; a first one of the horizontal edges extends alongside the inlet manifold, a second one of the horizontal edges extends alongside the outlet manifold and the vertical edges extend between the horizontal edges on
10 opposing sides of the effective absorbing zone.

6. The solar collector according to claim 5, wherein the effective absorbing zone has dimensions W1 and L1 and the peripheral side wall has dimensions W2 and L2; W1 being defined by the length of the inlet or outlet manifolds, L1 being measured along the axis between the inlet and outlet manifolds, W2 being measured
15 between the inner faces of opposing vertical edges, and L2 being measured between the inner faces of opposing horizontal edges, wherein L1 is smaller than L2 and W1 is smaller than W2.

7. The solar collector according to claim 6, wherein the ratio of L1 to L2 lies substantially between 0.90 and 0.98 when measured in normal room temperature
20 of between 20 and 29 degrees Celsius.

8. The solar collector according to claims 6 or 7, wherein the ratio of W1 to W2 lies substantially between 0.90 and 0.98 when measured in normal room temperature of between 20 and 29 degrees Celsius.

9. The solar collector according to claim 6, wherein the ratio of L1 to L2
25 lies substantially between 0.94 and 0.96 when measured in normal room temperature of between 20 and 29 degrees Celsius.

10. The solar collector according to claims 6 or 9, wherein the ratio of W1 to W2 lies substantially between 0.92 and 0.94 when measured in normal room temperature of between 20 and 29 degrees Celsius.

11. The solar collector according to claim 1, wherein the manifold that is flexibly fixed to the housing is the inlet manifold through which fluid enters the solar collector, the inlet manifold extending between two ends and the at least one flexible joint communicates with the inlet manifold at a location along the manifold that is spaced from the ends.

12. The solar collector according to claim 11, wherein the effective absorbing zone is formed from a plurality of modular units, each modular unit comprising an inlet sub-manifold for receiving fluid entering the modular unit, a spaced apart outlet sub-manifold for communicating fluid out of the modular unit and the two spaced-apart sub-manifolds being interconnected by some of the a plastic tubes of the solar collector, inlet sub-manifolds of adjacent modular units being attached to each other to form the inlet manifold of the solar collector, and outlet sub-manifolds of adjacent modular units being attached to each other to form the outlet manifold of the solar collector, wherein the at least one flexible joint communicates with the inlet manifold adjacent a location where two inlet sub-manifolds that form the inlet manifold adjoin.

13. The solar collector according to claim 5 and comprising a pair of inlet ports and a pair of outlet ports formed on the peripheral side wall of the housing, the inlet ports being located on opposing vertical edges of the housing adjacent the inlet manifold and the outlet ports being located on opposing vertical edges of the housing adjacent the outlet manifold.

14. An absorption zone for solar energy comprising first and second solar collectors according to claim 13, a given vertical edge of the first solar collector being positioned adjacent and alongside a given vertical edge of the second solar collector with the cover of both solar collectors facing the same direction, wherein the inlet port on the given vertical edge of the first solar collector is in fluid communication with the inlet port on the given vertical edge of the second solar collector and the outlet port on the given vertical edge of the first solar collector is

- 15 -

in fluid communication with the outlet port on the given vertical edge of the second solar collector.

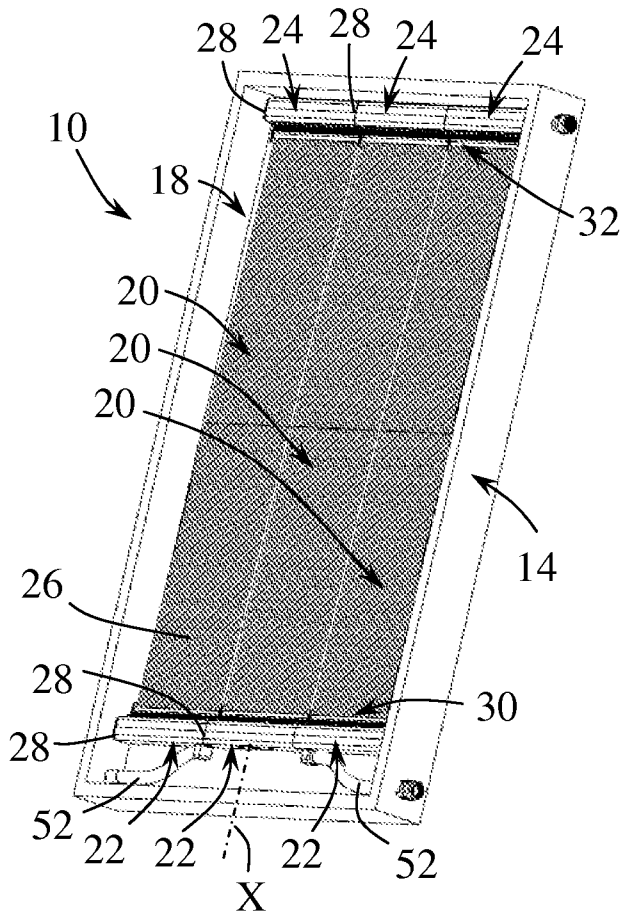

Fig. 1B

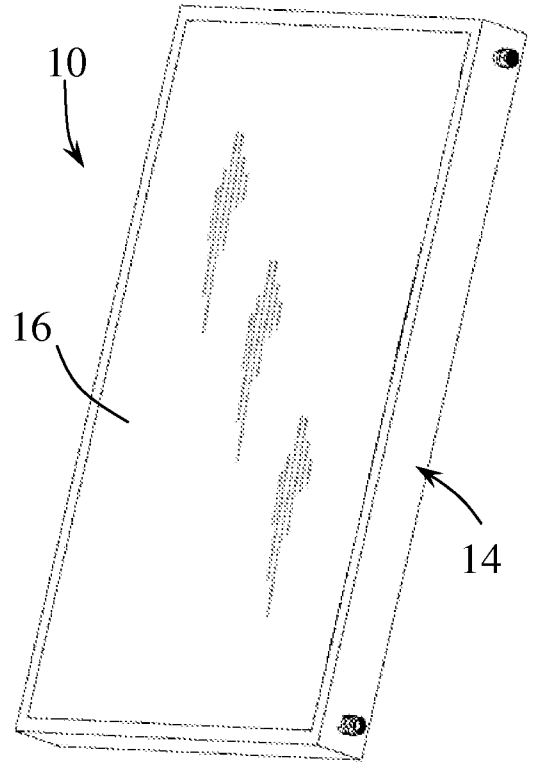

Fig. 1A

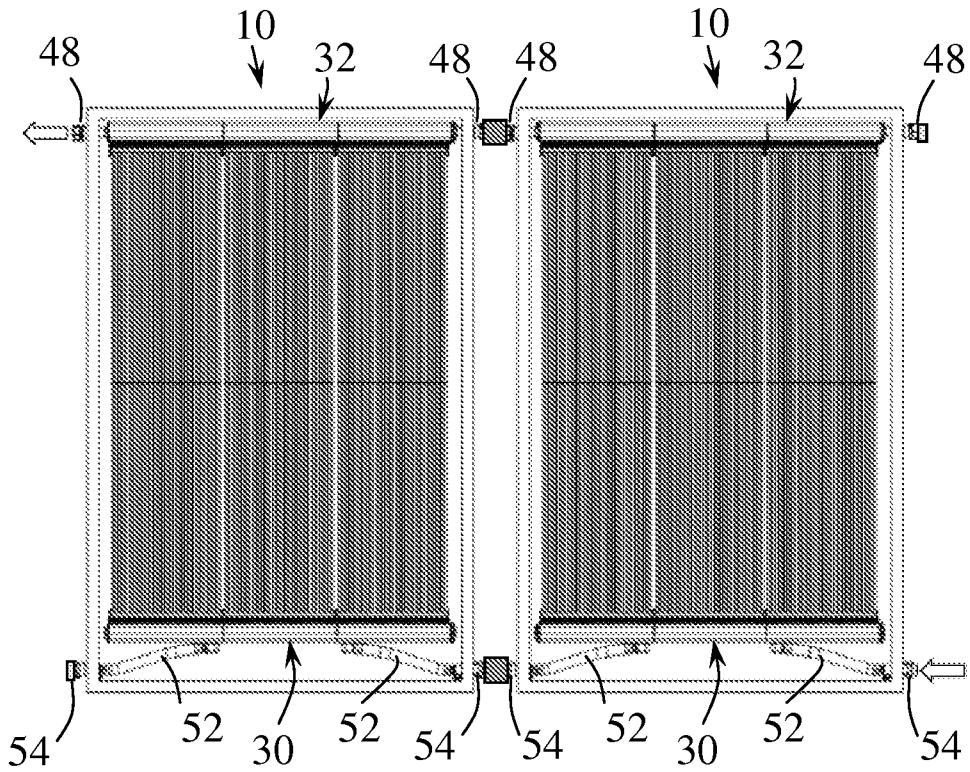

Fig. 2

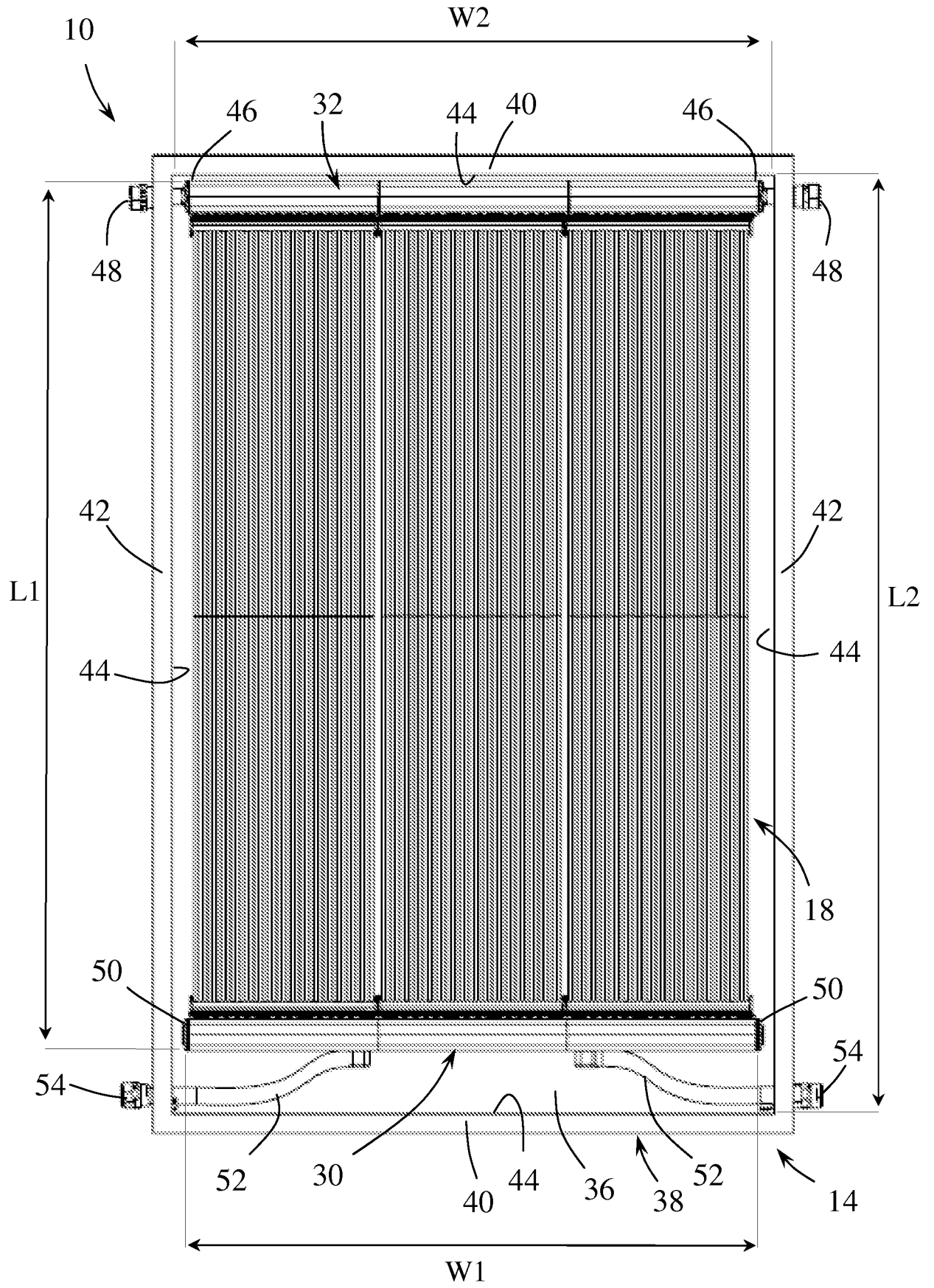

Fig. 3