

(19) World Intellectual Property
Organization
International Bureau



(43) International Publication Date
31 December 2003 (31.12.2003)

PCT

(10) International Publication Number
WO 2004/000104 A2

- (51) International Patent Classification⁷: **A61B** Fairfield Road, Minnetonka, MN (US). **GRYSKIEWICZ, Joseph M.**; c/o Incisive Surgical, Inc., 1409 Fairfield Road, Minnetonka, MN (US). **SMITH, Delmer L.**; c/o Incisive Surgical, Inc., 1409 Fairfield Road, Minnetonka, MN (US).
- (21) International Application Number: PCT/US2003/019948
- (22) International Filing Date: 25 June 2003 (25.06.2003)
- (25) Filing Language: English
- (26) Publication Language: English
- (30) Priority Data: 10/179,628 25 June 2002 (25.06.2002) US
- (71) Applicant: **INCISIVE SURGICAL, INC.** [US/US]; 1409 Fairfield Road, Minnetonka, MN (US).
- (72) Inventors: **PETERSON, James A.**; c/o Incisive Surgical, Inc., 1409 Fairfield Road, Minnetonka, MN (US). **SPERRY, Christopher J.**; c/o Incisive Surgical, Inc., 1409
- (74) Agents: **PEDERSEN, Brad** et al.; Patterson, Thunte, Skaar & Christensen, P.A., 4800 IDS Center, 80 South Eighth Street, Minneapolis, MN 55402-2100 (US).
- (81) Designated States (*national*): AE, AG, AL, AM, AT, AU, AZ, BA, BB, BG, BR, BY, BZ, CA, CH, CN, CO, CR, CU, CZ, DE, DK, DM, DZ, EC, EE, ES, FI, GB, GD, GE, GH, GM, HR, HU, ID, IL, IN, IS, JP, KE, KG, KP, KR, KZ, LC, LK, LR, LS, LT, LU, LV, MA, MD, MG, MK, MN, MW, MX, MZ, NI, NO, NZ, OM, PH, PL, PT, RO, RU, SC, SD, SE, SG, SK, SL, TJ, TM, TN, TR, TT, TZ, UA, UG, UZ, VC, VN, YU, ZA, ZM, ZW.
- (84) Designated States (*regional*): ARIPO patent (GH, GM, KE, LS, MW, MZ, SD, SL, SZ, TZ, UG, ZM, ZW),

[Continued on next page]

(54) Title: MECHANICAL METHOD AND APPARATUS FOR BILATERAL TISSUE FASTENING

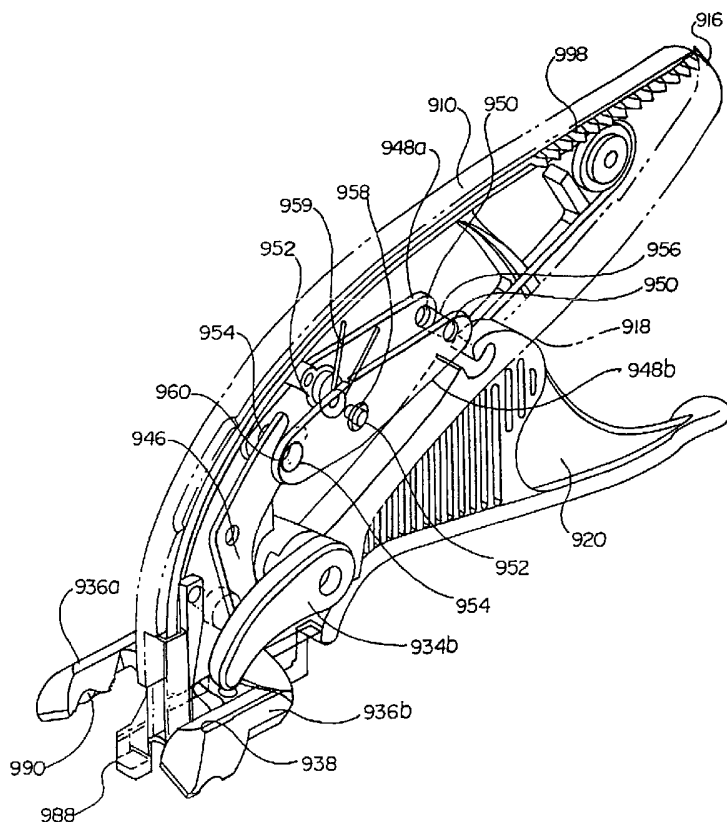

(57) Abstract: A mechanical system for bilaterally securing tissue preferably utilizes a tissue manipulator apparatus to approximate a portion of an interior surface of each of two pieces of living tissue along a vertical interface below an exterior surface of the tissue without overlapping 5 either interior surface across the vertical interface. An applicator apparatus includes a driving head portion positioned in the vertical interface and at least partially below the exterior surface and a handle portion positioned at least partially above the exterior surface. The applicator apparatus bilaterally drives at least one portion of a fastener through each piece of the living tissue behind the interior surface of that piece of tissue such that the fastener is positioned below 10 the exterior surface and a portion of the fastener is positioned generally transverse to the vertical interface. Preferably, the manipulator apparatus and the applicator apparatus are arranged together as part of a hand-held instrument capable of carrying and deploying multiple fasteners.

WO 2004/000104 A2



Eurasian patent (AM, AZ, BY, KG, KZ, MD, RU, TJ, TM),
European patent (AT, BE, BG, CH, CY, CZ, DE, DK, EE,
ES, FI, FR, GB, GR, HU, IE, IT, LU, MC, NL, PT, RO,
SE, SI, SK, TR), OAPI patent (BF, BJ, CF, CG, CI, CM,
GA, GN, GQ, GW, ML, MR, NE, SN, TD, TG).

For two-letter codes and other abbreviations, refer to the "Guidance Notes on Codes and Abbreviations" appearing at the beginning of each regular issue of the PCT Gazette.

Published:

- *without international search report and to be republished upon receipt of that report*

-1-

**MECHANICAL METHOD AND APPARATUS
FOR BILATERAL TISSUE FASTENING**FIELD OF THE INVENTION

5 The present invention relates generally to the field of surgical instruments such as surgical staplers, clip applicators and sutureless closure devices. More particularly, the present invention relates to a mechanical method and apparatus for fastening tissue, such as skin tissue, with a fastener positioned below the tissue surface that bilaterally secures opposed pieces of tissue.

10

BACKGROUND OF THE INVENTION

 When an opening in tissue is created either through an intentional incision or an accidental wound or laceration, biological healing of the opening commences through the proximity of the opposed living tissue surfaces. If the opening is very large or if its location
15 subjects the wound to continual movement, a physician will seek to forcibly hold the sides of the opening in close proximity so as to promote the healing process.

 In the case of skin tissue, for example, healing occurs best when the opposing dermal layers of the skin tissue are held in proximity with each other. Human skin tissue is comprised of three distinct layers of tissue. The epidermal layer, also known as the epidermis, is the
20 outermost layer and includes non-living tissue cells. The dermal layer, or dermis, is the middle layer directly below the epidermal layer and comprises the living tissue of the skin that is the strongest of the three layers. The subcutaneous, or hypodermis layer is the bottom layer of skin tissue and includes less connective tissue making this the weakest layer of skin tissue.

 The most prevalent method for forcibly closing a tissue opening is through the use of a
25 suture or "stitches." As early as the second century, the Greeks were using sutures to physically

-2-

close skin openings. In its simplest form, a suture is simply a length of material that is attached to a tissue-piercing device, such as a needle, and looped through the opposing sides of an opening. The suture is then pulled tight and the loop closes causing the opposing sides of the tissue to come into close physical proximity. The suture loop is held tight by the tying of a knot or some other locking mechanism. The first sutures were made of animal gut. Eventually other natural suture materials including leather, horsehair, flax, cotton and silk came into use.

As the sciences of medical and materials technology have advanced over the course of the past century, new bioabsorbable materials have been developed to further improve upon the basic suturing concept. Examples of modern improvements to the suturing process include enhancements to the suturing apparatus as shown, for example, in U.S. Patents Nos. 2,439,383, 2,959,172 and 3,344,790, as well as advances in sutures and suture materials as shown, for example, in U.S. Patents Nos. 3,123,077, 3,297,033, 3,636,956, 3,792,010 4,027,676 and 4,047,533.

While traditional suturing remains a popular method of effectuating closure of skin openings, the use of staples and staplers as a skin closure technique has become increasingly popular, especially in surgical settings where the opening is created through a purposeful incision. In these settings, the incision tends to make a clean, straight cut with the opposing sides of the incision having consistent and non-jagged surfaces. Typically, stapling of a skin opening, for example, is accomplished by manually approximating the opposing sides of the skin opening and then positioning the stapler so that a staple will span the opening. The stapler is then manipulated such that the staple is driven into the skin with one leg being driven into each side of the skin and the cross-member of the staple extending across the opening external to the skin surface. Generally, the legs of the staple are driven into an anvil causing the staple to deform so as to retain the skin tissue in a compressed manner within the staple. This process can

-3-

be repeated along the length of the opening such that the entire incision is held closed during the healing process.

Much work has been devoted to improving upon the basic stapling process. Developments have gone in a variety of directions and include work devoted to the stapling apparatus as shown, for example, in U.S. Patents Nos. 3,082,426, 3,643,851, 4,410,125, 4,493,322, 4,592,498, 4,618,086, 4,776,506, 4,915,100, 5,044,540, 5,129,570, 5,285,944, 5,392,979, 5,489,058, 5,551,622, 5,662,258, 5,794,834, 5,816,471, 6,131,789 and 6,250,532. In addition to the stapling apparatus, developments have also been made in the staple design as shown, for example, in U.S. Patents Nos. 2,351,608, 2,526,902, 2,881,762, 3,757,629, 4,014,492, 10 4,261,244, 4,317,451, 4,407,286, 4,428,376, 4,485,816, 4,505,273, 4,526,174, 4,570,623, 4,719,917, 4,741,337, 5,007,921, 5,158,567, 5,258,009, 5,297,714, 5,324,307, 5,413,584, 5,505,363 and 5,571,285.

While modern suturing and stapling techniques continue to provide an effective manner of effectuating skin closure, there remains a series of inherent disadvantages in using either of 15 these techniques. The standard technique for both suturing and stapling includes puncturing both the epidermis and dermis. This can result in a wound closure having an unaesthetically pleasing appearance on the surface of the skin. The presence of the fastener exposed through the skin surface provides an opportunity for infection and for accidentally catching the fastener and tearing the wound open. In the case of non-absorbable fasteners, further action by a medical 20 professional is necessary in order to remove the fastener once biological healing is complete.

In order to overcome these limitations, practitioners have developed a number of specialized suturing techniques where the suture is passed only through the dermis effectively positioning the suture below the skin surface, or in a subcuticular fashion. A surgeon has the choice of placing individual or interrupted sutures along the length of an opening. Another

-4-

suturing option is for the surgeon to use a single strand of suture material to place a plurality of continuing suture loops or running sutures along the length of an opening. While the presence of the suture below the surface can improve the aesthetic nature of the closure, it requires greater skill and technique to accomplish effectively and takes longer than conventional external
5 suturing.

While there has been active development of dermal layer suturing techniques, little has been done in the area of staples and staplers for use in connection with the dermal layer. In a series of patents issued to Green et al., including U.S. Patents Nos. 5,292,326, 5,389,102, 5,489,287 and 5,573,541, a subcuticular stapling method and apparatus are disclosed that were
10 ultimately commercialized as the U.S. Surgical SQS Subcuticular Stapling Apparatus. The Green et al. patents describe a stapling technique employing a handheld apparatus with jaws to proximate, interdigitate and overlap opposing sides of dermal layer tissue along the length of a skin opening. The apparatus then drives a single spike through the interdigitated and overlapped dermal layers of the opposing skin surfaces in order to secure both sides of the dermal tissue on
15 the single spike. Although this technique reduced the time required to effectuate a subcuticular skin closure, the SQS device was not commercially successful in part because the resulting closure produced an undesirable wave-like scar that sometimes did not heal effectively.

While many improvements have been made to mechanical tissue closure techniques, it would be desirable to provide a mechanical tissue closure system that is capable of effectively
20 delivering fasteners below the skin surface so as to produce an efficient and efficacious tissue closure.

SUMMARY OF THE INVENTION

The present invention is a mechanical system for bilaterally securing skin tissue.

-5-

Preferably, a tissue manipulator is used to approximate a portion of an interior surface of each of two pieces of living dermis tissue along a vertical interface below an exterior surface without overlapping either interior surface across the vertical interface. An applicator apparatus includes a driving head portion positioned in the vertical interface and at least partially below the exterior surface, and a handle portion positioned at least partially above the exterior surface. The applicator apparatus bilaterally drives at least one portion of the fastener through each piece of the living dermis tissue behind the interior surface of that piece of tissue such that the fastener is positioned below the exterior surface and a portion of the fastener is positioned generally transverse to the vertical interface.

Unlike existing mechanical tissue fastening systems, the present invention recognizes the need for and advantages of a fastener system that captures and retains dermal tissue in a compressed state within a preferably bioabsorbable fastener that is not inserted through the epidermal skin layer. The mechanical fastening system of the present invention is able to consistently and repeatedly interface a fastener with a target tissue zone in the dermal layer such that the fastener inserted into the target tissue zone produces an effective and aesthetically pleasing closure of a tissue opening.

BRIEF DESCRIPTION OF THE DRAWINGS

Fig. 1 shows a typical opening in skin tissue such as may be closed by the present invention.

Fig. 2 shows a cross-sectional view of the skin tissue and opening of Fig.1.

Fig. 3 shows a cross-sectional view of everted skin tissue.

Fig. 4 shows a perspective cross-sectional view of an opening in skin tissue at rest, indicating optimal bilateral target tissue zones.

-6-

Fig. 5 shows an enlarged view of a target tissue zone.

Fig. 6 shows the view of Fig.4 with the skin tissue everted.

Fig. 7 is a perspective view of an embodiment of the applicator apparatus of the present invention.

5 Fig. 8 is a perspective view of the lower handle and driving head portions of the applicator apparatus of Fig.7.

Fig. 9 is a top plan view of the lower handle and driving head portions of the applicator apparatus of Fig. 7.

Fig. 10 is a partial cross-sectional view of the driving head portion shown in Fig. 9.

10 Fig. 11 is a side elevation view of the lower handle and driving head portions of the applicator apparatus of Fig. 7.

Fig. 12 is a perspective view of the lower handle and driving head portions as depicted in Fig. 8 with a fastener positioned therein.

15 Fig. 13 is another perspective view of the lower handle and driving head portions as depicted in Fig. 8 with a fastener positioned therein.

Fig. 14 is a phantom view of the applicator apparatus of an embodiment of the present invention having an automated fastener delivery and storage mechanism.

Fig. 15 is an enlarged phantom view of the apparatus of Fig. 14.

Fig. 16 is a partial view of the apparatus of Fig. 14.

20 Fig. 17 is a perspective view of an embodiment of a manipulator apparatus according to the present invention.

Fig. 18 is an enlarged view of the jaw portions of the manipulator apparatus of Fig. 17.

Fig. 19 is a perspective view of an embodiment of a fastener according to the present invention.

-7-

Fig. 20 is a top plan view of the fastener depicted in Fig. 19.

Fig. 21 is a perspective view showing the orientation of applicator and manipulator apparatus during a step of an embodiment of the method of the present invention.

Fig. 22 is a perspective view of the apparatus during another step of an embodiment of
5 the method of the present invention.

Fig. 23 is a perspective view of the apparatus during yet another step of an embodiment
of the method of the present invention.

Fig. 24 is a perspective view of the apparatus during still another step of an embodiment
of the method of the present invention.

10 Fig. 25 is a top plan view of an alternative embodiment of a fastener according to the
present invention.

Fig. 26 is a side elevation view of the fastener of Fig. 25.

Fig. 27 is a view of the fastener of Fig. 25 in a deployed condition.

Fig. 28 is a view of an applicator assembly according to an alternative embodiment of the
15 invention.

Fig. 29 is another view of an applicator assembly according to an alternative embodiment
of the invention.

Fig. 30 is a pictorial representation of a skin opening closed with conventional
subcutaneous sutures.

20 Fig. 31 is a pictorial representation of a skin opening closed by conventional surgical
stapling.

Fig. 32 is a pictorial representation of an opening closed with the prior art interdigitated
subcuticular stapler.

-8-

Fig. 33 is a pictorial representation of an opening closed using the bilateral fastening technique of the present invention.

Fig. 34 is a longitudinal cross-sectional view of an alternative embodiment of the present invention showing operation of corresponding guiding features on the tissue manipulator and the applicator.

Fig. 35 is a longitudinal cross-sectional view of an alternative embodiment of the present invention showing ball tip ends on the tissue manipulator and corresponding semi-spherical areas on the applicator.

Fig. 36 is a top cross-sectional view of the alternative embodiment shown in Fig. 35.

Fig. 37 is an isometric view of an alternate embodiment of the applicator assembly in which the fasteners are inserted obliquely into the tissue.

Fig. 38 is an isometric view of an alternate embodiment of the present invention in which the tissue manipulator and the applicator assembly are incorporated in a single handheld instrument.

Fig. 39 is a plan view of an embodiment of a fastener showing the inner cross-sectional area.

Fig. 40 is an exploded perspective view of an alternative embodiment of the present invention in which a tissue manipulator assembly and an applicator assembly are incorporated into a single handheld surgical instrument.

Fig. 41 is a side view of the handheld surgical instrument shown in Fig. 40.

Fig. 42 is a side view of the handheld surgical instrument shown in Fig. 40.

Fig. 43 is a perspective view of the handheld surgical instrument shown in Fig. 40.

Fig. 44 is a perspective view of the handheld surgical instrument shown in Fig. 40.

Fig. 45 is a side view of a tissue form.

-9-

Fig. 46 is a perspective view of the tissue form shown in Fig. 45.

Fig. 47 is a side view of an insertion block.

Fig. 48 is a perspective view of the insertion block shown in Fig. 47.

Fig. 49 is a front view of the insertion block shown in Fig. 47.

5 Fig. 50 is a top view of an alternative embodiment of a surgical fastener.

Fig. 51 is a perspective view of an alternative embodiment of a surgical fastener.

Fig. 52 is a top view of the handheld surgical fastener of Fig. 40 loaded with a surgical fastener.

10 Fig. 53 is a top view of a pair of piercing members and a backspan loaded with a surgical fastener.

Fig. 54 is a perspective view of a piercing member.

Fig. 55 is a perspective view of an arm tip.

Fig. 56 is a side view of the handheld surgical instrument of Fig. 40.

15 Fig. 57 is a perspective view showing a tissue positioning step of the through-and-through bilateral fastening technique of the present invention.

Fig. 58 is a perspective view showing a tissue positioning step of the through-and-through bilateral fastening technique of the present invention.

Fig. 59 is a perspective view showing a tissue positioning step of the through-and-through bilateral fastening technique of the present invention.

20 Fig. 60 is a perspective view showing a tissue capture and forming step of the through-and-through bilateral fastening technique of the present invention.

Fig. 61 is a perspective view showing a tissue capture and forming step of the through-and-through bilateral fastening technique of the present invention.

Fig. 62 is a side view of the handheld surgical instrument of Fig. 40.

-10-

Fig. 63 is a perspective view of a wound closure following insertion of surgical fasteners using the through-and-through bilateral fastening technique of the present invention.

Fig. 64 is a side view of an alternative embodiment of the present invention in which a tissue manipulator assembly and an applicator assembly are incorporated into a single handheld surgical instrument having a multi-shot fastener insertion design.

Fig. 65 is a sectional, perspective view of the handheld, multi-shot surgical instrument of Fig. 64.

Fig. 66 is a sectional, side view of the handheld multi-shot surgical instrument of Fig. 64.

Fig. 67 is a front, partial section view of the handheld multi-shot surgical instrument of Fig. 64.

Fig. 68 is a perspective, partial section view of the handheld multi-shot surgical instrument of Fig. 64.

DETAILED DESCRIPTION OF THE PREFERRED EMBODIMENTS

In Figs. 1-3 there is shown a depiction of a typical opening 50 in the surface of skin 52, such as may be made, for example, by a surgical incision or a wound. As illustrated in Fig. 1, for purposes of describing the present invention, opening 50 may be described as having a length or longitudinal orientation parallel to the y-y axis, a width orientation parallel to the x-x axis, and a depth orientation parallel to the z-z axis. The x-y-z axis for purposes of the present invention is defined with respect to an external tissue surface, which in the case of skin 52 is the outer surface. References to a vertical and horizontal planar orientation in connection with the present invention are made with respect to the external tissue surface at the site of the opening in question. The vertical inner surfaces 60 formed by each side of the opening 50 can be visualized as meeting along a generally vertical interface 51. It will be understood that in the case of an

-11-

opening that extends over a curved tissue surface, the corresponding horizontal and vertical surfaces associated with the opening will be defined with respect to such curved tissue surface. It also will be understood that the vertical interface 51 may be vertical in only one orientation with respect to the tissue surface, such as in the case when an angled incision has formed the opening 50.

As is best illustrated in the sectional views of Figs. 2 and 3, human skin 52 generally has three discrete layers. These layers comprise an epidermal layer 54 of mostly non-living tissue having an exterior surface 55, a dermal layer 56 of mostly living tissue, and a subcutaneous tissue layer 58. Although the preferred embodiment of the present invention will be described with respect to human skin tissue 52, it will be understood that the present invention is applicable to closure of openings in other types of tissue having generally defined surfaces, such as fascia, membranes organs, vessels, vasculature, vascular pedicles, skin grafts, bladder and other biocompatible materials with generally defined surfaces such as artificial skin, artificial membranes and synthetic mesh.

It has long been known that the most rapid healing of a skin opening with a minimum of scarring occurs when the inner surfaces 60 of the living dermal layer 56 at each side of the vertical interface 51 of skin opening 50 are brought together and held in close contact in what is referred to as an everted position as is shown in exaggerated fashion in Fig. 3. To the extent that the primarily non-living material of epidermal layer 54 can be excluded from the healing opening, the rapidity and level of scar tissue formed during the healing process will be improved.

The ability of the present invention to provide a more effective and efficacious tissue closure can be seen with reference to Figs. 30-33, which show skin openings closed by various prior art methods as compared with an opening closed using the bilateral fastening techniques of the present invention. In Fig. 30, there is shown a skin opening closed with subcutaneous

-12-

sutures. The generally everted condition of the closed opening can produce unattractive scarring and less than optimal healing if the eversion is excessive or inadequate. As can be seen from Fig. 30, obtaining consistency from suture to suture is difficult and the quality of the closure is highly dependent upon the skill of the surgeon. Fig. 31 shows a skin opening closed by conventional surgical stapling. In addition to the generally unattractive appearance of the closed opening, staple openings and the excessive everted condition of the opening may lead to undesirable scarring. In addition, if non-resorbable staples are used, the staples must be removed before complete healing can occur. Fig. 32 shows a depiction of an opening closed with the interdigitated subcuticular stapler known as the SQS device that is described, for example, in U.S. Patents Nos. 5,292,326, 5,389,102, 5,489,287 and 5,573,541. The characteristic undulating appearance caused by the overlapping interdigitation of the skin may lead to an unusual appearing scar in the healed opening. The overlapping and interdigitation of the skin can also cause epidermis tissue to be interposed between dermal layers, thereby leading to incomplete healing or excessive scarring.

By comparison, an opening that has been partially closed by the method and using the apparatus of the present invention is shown in Fig. 33. As shown, the closed portion of the opening is tightly closed, yet lies flat without undue eversion of the opening leading to better healing performance with minimal scarring. There is consistency in the closure from fastener to fastener. Because the fasteners are positioned below the skin surface (i.e., subcuticular), the fasteners are not exposed and there is no puncturing or button holing of the epidermis that can lead to the increased possibility of infection or interference with the normal healing process. In addition, if fasteners made of a bioresorbable, bioabsorbable or even a bioerodible material are used, there is no need to later remove the fasteners.

-13-

The advantages of the present invention are accomplished by an apparatus and method that bilaterally engages target tissue zones 70 on each side of a skin opening 50 with a fastener that is preferably made of a bioresorbable material. As used in connection with the present invention, the term bilateral refers to at least two axis of insertion for a fastener that are on
5 separate sides of the vertical interface 51 of an opening 50. The bilateral engagement may be made either simultaneously or sequentially, and the fastener used may have a variety of configurations and be oriented in a variety of ways as will be further described herein. The location, geometry and orientation of the fastener and the dermal layers in relation to the mechanical apparatus of the present invention are all important considerations to obtaining the
10 most optimal contact and compression of the dermal layer for efficacious closing of the opening. While the skin opening 50 will be described in connection with an opening in a single piece of tissue, it will be understood that the opening 50 could also be between two separate and otherwise unconnected pieces of tissue, or even between a piece of tissue and a piece of biocompatible material to be secured to that piece of tissue.

15 As is shown in Figs. 4 and 5, there exists an optimal target tissue zone 70 on each side of vertical interface 51 that may be bilaterally engaged by a fastener in order to achieve optimal dermal contact for healing. This target tissue zone 70 lies within the dermal layer 56, and can be visualized as a rectangular cross-sectional area when the tissue is in a relaxed condition as shown best in Fig. 4. In addition, within target tissue zone 70, there exists a most preferred area 72 for
20 tissue engagement. In the depth orientation, target tissue zone 70 lays between a distance L3 of about 0.1 mm below the surface 55 of epidermal layer 54, and a distance L4 up to 2.0 mm below the surface 55. The most preferred area 72 lies between a distance L5 of about 0.2 mm and a distance L6 of about 0.8 mm below the surface. In the width orientation, target tissue zone 70 lies between a distance L7 of about 1.0 mm and a distance L8 of about 20.0 mm from vertical

-14-

interface 51. Most preferred area 72 lies between a distance L9 of about 2.0 mm and a distance L10 of about 8.0 mm from vertical interface 51. Because the target tissue zone 70 is not visible to an operator, the manipulator assembly 400 and applicator assembly 100 are preferably designed to consistently and repeatedly enable the operator to position the target tissue zone 70
5 for deployment of a fastener 400.

As illustrated in Fig. 6, due to the inherent flexibility and resilience of skin tissue, it is most desirable that a fastener 400 be deployed into the target tissue zone 70 while the skin opening is everted. By compressing the everted dermal layers 56 on either side of the opening 50 into the fastener 400, the dermal layers 56 are retained in close contact with each other by the
10 fastener 400 after the everting pressure is removed and the skin relaxes into a flat condition as shown in Fig. 4.

An embodiment of the apparatus of the present invention is shown in Figs. 7-20. Generally, the apparatus includes an applicator assembly 100, a tissue manipulator assembly 300, and a fastener 400.

15 An embodiment of applicator assembly 100 is shown in Figs. 7-16. The assembly generally comprises upper handle portion 110 and lower handle portion 120, to which is attached driving head 140. Trigger 200, which pivots about pivot 202 is provided to allow user actuation of the mechanism. Although a manual pivoting trigger arrangement 200 is shown, it will be understood that a variety of other user-actuated manual triggers, buttons or actuator mechanisms
20 may be utilized with the applicator assembly 100, such as a push button, slide mechanism, cam mechanism, spring actuated apparatus, cable actuated pull mechanism, rotating mechanism or tab actuated trigger. Alternatively, an automatic actuator in the form of an electronic, pneumatic, motion controlled, remote controlled or computer-activated trigger may be used to operate the applicator 100.

-15-

In Figs. 8-13, there are shown detailed views of an embodiment of a driving head 140 and lower handle portion 120. Driving head 140 is preferably U-shaped and has an anvil portion 142 separated from backing portion 144 by a cross-member 146, thereby forming a gap 148. Cross-member 146 preferably has concave areas 150, which are shaped to correspond to tissue manipulator surfaces 318 of tissue manipulator assembly 300, allowing the dermal layer 56 of skin to be compressed into contact within gap 148, and with target tissue zones 70 present for capture on either side of vertical interface 51 as will be further explained hereinbelow. Although driving head 140 is shown in a fixed orientation relative to lower handle portion 120 and upper handle portion 110, it will be understood that driving head 140 may be articulated, either in the plane of the vertical interface 51 or perpendicular to the plane of the vertical interface 51, to allow for increased maneuverability and orientation of driving head 140. Alternatively, lower handle portion 120 may be articulated relative to upper handle portion 110, or both lower handle portion 120 and driving head 140 may be articulated.

Preferably, anvil portion 144 of driving head 140 has apertures 152 formed therethrough. Apertures 152 are appropriately sized so as to slidably receive penetrators or pilot needles 154, 156 and may be bored directly into the material of anvil portion 144 or may be lined with a metal guide tube or the like inserted into a bore in anvil portion 144. Pilot needles 154, 156 have a generally arcuate shaped cross-section throughout distal portions 155, 157, and a solid cylindrical cross-section in proximal portions 159, 161. Each distal portion 155, 157 has an inner concave surface 158, 160 for accommodating and retaining a fastener 400, and each proximal portion 159, 161 engages the back surface of the fastener 400, allowing the fastener to be advanced distally with the needles. The distal ends 162, 164 of pilot needles 154, 156 have a sharp point for penetrating skin. Pilot needles 154, 156 are vertically disposed at a distance d_1 below top surface 166 of anvil portion 142. It is preferably that top surface 166 be usable as a

-16-

reference datum for visually gauging whether pilot needles 154, 156 are located within target tissue zone 70. Accordingly, it is preferable that distance d1 be between 0.1 mm and 2.0 mm, and most preferably between 0.2 mm and 0.8 mm, so that when top surface 166 is aligned with the outer skin surface, pilot needles 154, 156 are located within target tissue zone 70 and most preferably within most preferred area 72.

Delivery mechanism 128 serves to eject a fastener from driving head 140. Preferably, slide block 122 is slidably mounted on guides 124, 126, within lower handle portion 120. Slide block 122 is engaged with trigger 200 so that actuation of the trigger causes sliding movement of slide block 122. Pilot needles 154, 156 are fixedly attached to slide block 122, and extend outwardly through backing portion 144 of driving head 140 through slot 168. Thus, back and forth sliding motion of slide block 122 causes pilot needles 154, 156 to be extended and retracted from slot 168, gap 148 and apertures 152. It will be understood that any number of mechanical driving arrangements can be used to impart the necessary force to pilot needles 154, 156, or alternatively to the fastener 400 directly. Examples include sliding mechanisms, cam mechanisms, spring-operated mechanisms, screw drives, pneumatic drives, automated motion control drives, or the like.

Pilot needles 154, 156 are preferably spaced apart by an interneedle distance of between about 2.0 mm and 20 mm and most preferably between about 4.0 mm and 16.0 mm, so that when the driving head is placed within a skin opening to be fastened, and with the skin opening aligned with the approximate midpoint between the pilot needles, the pilot needles will be located within the width orientation of the target tissue zone 70.

Although single fasteners may be inserted manually one-by-one between pilot needles 154, 156, an alternative embodiment of applicator assembly 100, shown in phantom in Figs. 14-16 has an automated fastener delivery and storage mechanism 220. In this mechanism, fasteners

-17-

are preferably stacked vertically in echelon fashion surrounding a guide member 224, and are biased downwardly with a resilient member such as a spring (not shown). Housing 222 is provided to protect the mechanism. The bottom-most fastener in the echelon is engaged with pilot needles 154, 156. As each fastener 400 is emplaced in the skin through operation of the applicator assembly 100 as described herein, and slide block 122 is returned to the proximal limit of travel, the downward bias of the echelon causes the immediately vertical adjacent fastener to move downward and become engaged within pilot needles 154, 156. The next fastener may then be emplaced in the skin, and the process repeated. Again, it will be appreciated that numerous arrangements and configurations for providing and deploying multiple fasteners within the context of the present invention could be used, such as inline stacking in either a horizontal or vertical orientation, side-by-side stacking, rotational presentation via a circular chamber or magazine or belt or tape-attached presentation of the fasteners 400.

In Figs. 17 and 18, there is shown an embodiment of the tissue manipulator assembly 300 of the present invention. The proximal ends 307 of arms 302, 304 are joined together at fulcrum 306, forming the tweezer-like structure of the overall assembly. Gripping areas 312 are provided on each arm to allow gripping of the assembly with the fingers. Any suitable fastening method may be used at fulcrum 306, including rivets 316 as shown, or the arms 302, 304 may be welded, cast, or molded together or may otherwise be integrally formed together. The material and overall dimensions for arms 302, 304 are selected so as to allow the arms to be resiliently compressed inwardly with the fingers, and with a memory characteristic for returning to the original position upon the removal of pressure. In addition, the material used for the arms and other portions of the assembly are preferably thermally and chemically stable so as to allow sterilization with either heat or chemical means. The preferred material for arms 302, 304 is stainless steel.

-18-

At the distal ends 309 of each arm 302, 304 are formed tissue manipulator surfaces 318. Manipulator surfaces 318 are preferably semi-cylindrically shaped as shown, with the diametrical dimension of each semi-cylinder selected so as to conform to the diameter and shape of the concave areas 150 of applicator assembly 100. Skin gripping jaw members 314 are preferably attached to the exterior surfaces 326 of each arm member 302, 304. Each jaw member 314 has a backing portion 324 for attaching to the arms, and a pair of inwardly directed projections 320 disposed on both sides of manipulator surfaces 318. Directly opposed serrations 322 are preferably provided on the inward-most edge of each projection 320 for better skin purchase. Backing member 324 may be attached to each arm 302, 304 using any suitable attachment method, including mechanical fasteners such as the rivets 316 as shown. For reasons that will be further explained, it is preferable that each jaw member 314 is of sufficient resilience and is attached so that inwardly directed projections 320 may deflect separately from skin manipulator surfaces 318 under moderate finger pressure applied to arms 302, 304. This may be achieved through concerted selection of the material used for jaw member 314, the thickness dimension of backing member 324, and the free length L1 of each backing member 324 between the inwardly directed projections 320 and the fastener 316 closest to the distal end 309 of the arm. The objective of the design of the backing member 324 is to have the jaw members 314 engage tissue with a first force and have the manipulator surfaces 318 engage tissue between the jaw members 314 with a second force that is greater than the first force. In addition, the use of a pair of directed projections 320 on each side of the vertical interface 51 serves to stabilize the tissue laterally between the pair of projections 320.

Mechanical stops 330 are provided to prevent pressure beyond that necessary to ensure optimal approximation of tissue into gap 148 and concave portions 150 of applicator assembly 100 from being transmitted through manipulator surfaces 318. Preferably, mechanical stops 330

-19-

are set so that manipulator surfaces 318 close to a distance that is spaced apart from the inter-needle distance of pilot needles 154, 156 by a range of 0.2-0.8 millimeters, such that the total distance between mechanical stops 330 is 0.4-1.6 millimeters greater than the interneedle distance between pilot needles 154, 156. In a preferred embodiment in which the interneedle distance is set at 3.25 millimeter, the mechanical stops 330 would allow the surfaces 318 to close to within a range of 3.65-4.85 millimeters when approximating tissue into gap 148. Although jaw members 314 may be formed from any suitable material, the preferable material is stainless steel.

In Figs. 19 and 20, there is shown an embodiment of a fastener 400 of the present invention. Fastener 400 has body portion 402, which comprises a cross-member 408 connecting a pair of fork members or legs 406. The outer margins 410 of each leg 406 are dimensioned and shaped accommodatingly to the inner concave surfaces 158, 160, of pilot needles 154, 156, allowing fastener 400 to fit and slide between the distal portions 155, 157 of the needles, as is shown best in Figs. 12 and 13. Shoulders 414 preferably are provided to engage the solid cylindrical cross-section of the proximal portions 159, 161 of pilot needles 154, 156, thus allowing fastener 400 to be advanced distally with motion of the needles. The distal end 412 of each leg 406 is incurvately shaped to allow easier passage through an opening in skin, referred to as a skive, that is created by pilot needles 154, 156. Inwardly directed barbs 404 preferably are provided on each leg 406 to resist withdrawal of the fastener once emplaced.

Although an overall U-shape for the fastener 400, as shown in Figs. 19 and 20 is preferred, other shapes having a capability for bilateral tissue engagement are also possible and within the scope of the invention. Such other shapes include for example, but are not limited to, a square shape similar to an ordinary staple, a semi-circular or C-shape or a V-shape or W-shape, in which the cross-member 408 has bends or other features. While the shape of fastener 400 is

-20-

generally determined in a planar configuration, it will be recognized that other non-planar shapes and configuration can be used, such as a fastener having multiple projections for each leg 406, with each projection oriented in a different plane, or a fastener having cross-member 408 arranged in a V-shape projecting out of the normal plane of the fastener 400. Two leg members 5 406 are preferred, but it will be understood that additional leg members 406 could be added in the same or a different plane of the fastener 400 such that the leg members of each side of the fastener form a dident or trident configuration, for example.

As shown in Fig. 39, an inner cross-sectional area 409 is defined by the fastener 400 for capturing the compressed dermal tissue. In a preferred embodiment, inner cross-sectional area 10 409 ranges from 1.5 sq. mm to 50 sq. mm and most preferably about 5 sq. mm to 10 sq. mm. This area is generally defined by an inner diameter length of between 1.5 mm and 9 mm and most preferably about 3.8 mm and an inner diameter width of between 1 mm and 5 mm and most preferably about 2 mm. It will be apparent that numerous shapes and configurations can be used for the shape and arrangement of cross-sectional area 409. Preferably, inner cross-sectional area 15 409 is generally arrowhead shaped as a result of the positioning of the barbs 412. As will be described, the barbs 412 or similar anti-reversing projections resist against the withdrawal of fastener 400. While the barbs 412 are preferably oriented into the inner cross-sectional area 409, it will be appreciated that barbs 412 may be omitted or may be oriented outwardly.

Although it is possible for fastener 400 to be deformed during delivery and application, 20 preferably the majority of dermal tissue retained within cross-sectional area 409 is captured in a compressed state by a fastener 400 that is sufficiently rigid so as to retain the dimensional integrity of cross-sectional area 409 within +/- 30% of its designed area for a period of preferably at least 10 days. Most preferably, structural integrity of fastener 400 is maintained for at least 21 days. In this way, the dermal tissue captured in fastener 400 is retained in a

-21-

compressed state for a period sufficient to allow the biological healing process to occur without the dermal tissue being under tension during the healing process. Preferably, the dimensions of the fastener 400 and the operation of the applicator assembly 100 coordinate to create a compression ratio of dermal tissue within the inner cross-sectional area 409 that is greater than one. The compression ratio is defined either as a ratio of area or a ratio of width. In the case of width, the compression ratio is the ratio of the dimension defined by the position of the skive relative to the vertical interface 51 when the dermal tissue is at rest divided by the position of the skive relative to the vertical interface as held by the fastener 400. In the case of area, the compression ratio is the ratio of the area of dermal tissue that will be retained by the fastener 400 when that dermal tissue is at rest divided by the actual cross-sectional area 409.

Alternatively, it is possible to take advantage of the bilateral tissue fastening in the tissue target zone as taught by the present invention with a deformable fastener where the deforming of a bioresorbable or bioabsorbable fastener serves to provide at least some of the compression of the dermal tissue such that the need for a mechanical tissue manipulator is reduced or potentially eliminated. In this embodiment, a bioresorbable or bioabsorbable fastener would be deformed by the applicator apparatus in order to appropriately compress the dermal tissue. Deformation of a bioresorbable or bioabsorbable fastener could be accomplished in a number of ways, including prestressing the fastener into an open configuration such that it returns to a closed configuration, with or without mechanical assistance from the applicator, application of ultrasound, heat or light energy to alter the shape of, or reduce or relax stresses in, the fastener in situ, designing a polymer material with appropriate shapes and compositions that the material is deformable upon deployment without fracturing, or any combination of these techniques.

Fastener 400 is preferably formed from any suitable biodegradable material. The currently most preferred biodegradable material is a lactide/glycolide copolymer where the ratio

-22-

is never less than at least 10% of one element and preferably in a range of 60%-70% lactide. Examples of other suitable materials include poly(dl-lactide), poly(l-lactide), polyglycolide, poly(dioxanone), poly(glycolide-co-trimethylene carbonate), poly(l-lactide-co-glycolide), poly(dl-lactide-co-glycolide), poly(l-lactide-co-dl-lactide) and poly(glycolide-co-trimethylene carbonate-co-dioxanone). In addition, other suitable materials could include compositions with naturally occurring biopolymers such as collagen and elastin, or stainless steel, metal, nylon or any other biocompatible materials in the case of a non-absorbable fastener, or even various combinations of such materials depending upon the desired application and performance of the fastener.

10 With reference to Figs. 21-24, the operation of the apparatus of the present invention may now be explained and understood. A fastener 400 is first loaded between pilot needles 154, 156, as shown in Fig. 12. Slide block 122 is then proximally retracted to the fullest extent so that pilot needles 154, 156 and the fastener 400 are entirely within slot 168. Driving head 140 is then introduced into skin opening 50 and top surface 282 is aligned with the outer surface of the skin
15 as shown in Fig. 21. Tissue manipulator assembly 300 is placed with jaw members 314 on either side of driving head 140. Arms 302, 304 of manipulator assembly 300 are pressed inward so that jaws 314 engage the skin surface and begin to force the skin 52 into gap 148 in applicator assembly 100 as shown in Fig. 22. Serrations 322 provide purchase on the skin surface and prevent lateral slipping of the skin relative to the jaws. As further inward pressure is applied to
20 arms 302, 304, inwardly directed projections 320 engage side surfaces 170 of anvil portion 142 and side surfaces 172 of backing portion 144, each with a single thickness of skin trapped between as shown in Fig. 23. Still further inward pressure on arms 302, 304, as shown in Fig. 24, causes tissue manipulator surfaces to deflect inward slightly from jaws 314, until each engages concave area 150 of cross-member 146 with a layer of skin trapped in between. In this

-23-

position, inner surfaces 60 of dermal layer 56 are in direct contact with each other within gap 148 and substantially parallel with vertical interface 51, but are not overlapped or interdigitated.

In this embodiment, pilot needles 154, 156 are aligned generally horizontally and substantially parallel with the outer surface of the skin and are within target tissue zone 70.

5 Cross-member 408 of fastener 400 is positioned generally transverse to vertical interface 51 and a working plane of fastener 400 defined by cross-member 408 and legs 406 is generally horizontal in orientation. Trigger 280 is then actuated, causing slide block 122 to move proximally within lower handle portion 120, and advancing pilot needles 154, 156 into the skin, creating a skive through the target tissue zone 70 of the skin on each side of vertical interface 51.

10 Fastener 400 moves with pilot needles 154, 156, and each leg 406 of the fastener 400 is simultaneously driven into and through the skive. Once fastener 400 is advanced distally a sufficient distance so that barb tips 416 of fastener 400 enter apertures 152 and accordingly emerge from the skive, trigger 280 may be reversed so that slide block 122 moves proximally, retracting pilot needles 154, 156. Barbs 412 engage the skin, thereby preventing fastener 400

15 from being withdrawn with the pilot needles. Once slide block 122 has been fully retracted proximally, thereby causing pilot needles 154, 156 to be fully retracted from gap 148, the pressure on manipulator assembly 300 may be released and applicator assembly 100 can be moved proximally in the opening 50 to deliver another fastener 400 or can be removed from opening 50.

20 In addition to the embodiment of the apparatus described above wherein the legs of a fastener are simultaneously driven through the target tissue zone on each side of the skin opening and with the fastener legs oriented parallel to the epidermal skin surface, those of skill in the art will appreciate that other embodiments of a mechanical fastening system for openings in skin tissue are within the scope of the present invention. For instance, the working plane of fastener

-24-

400 defined by cross-member 408 and legs 406 may be oriented generally orthogonal, or oblique in at least one orientation, to the horizontal plane generally defined by exterior surface 55 of epidermal layer 54. In such an embodiment, fastener 400 may be inserted in a generally vertical orientation with legs 406 pointing generally in an upward direction or in a downward direction.

5 Another embodiment of the apparatus of the present invention wherein a fastener is driven sequentially through the bilateral target tissue zones is shown in Figs. 25-29. In one embodiment, fastener 500 has flexible body portion 502 with a barb 506 at distal end 505 and an attachment flap 504 at proximal end 503. Flexible body portion 502 is dimensioned so as to be received within either concave inner surface 158, 160 of pilot needles 154, 156. Attachment flap
10 504 has slot 508 formed therethrough, which is adapted to receive barb 506. In applicator assembly 100, anvil portion 142 has concave deflector 153 formed between apertures 152 and extending into a portion of each aperture 152 so that only an area of each aperture is open sufficient to allow the arcuate cross-section of pilot needles 154, 156 to pass. In operation, and with reference to Figs. 1-29, fastener 500 is axially aligned with pilot needle 154, and is inserted
15 within the corresponding concave inner surface of the needle with barb 506 oriented toward the point of the needle. Applicator assembly 100 is then introduced into the interface portion 51 of the skin opening 50 as described above. Tissue manipulator assembly 300 is then applied as before to bring the dermal layer 56 into contact within gap 148, and thereby properly positioning target tissue zone 70. As slide block 122 and the attached pilot needles 154, 156 are moved
20 distally through actuation of trigger 280, fastener 500 is advanced through the skin tissue on one side of skin opening 50 along with pilot needle 154 in which it is disposed. Once the tip of barb 506 reaches aperture 152, however, it is engaged by, and begins to slide laterally along, concave deflector 163, causing flexible body portion 502 to bend. As pilot needles 154, 156 are further advanced, barb 506 is turned in direction 180 degrees by deflector 163. It will be appreciated

-25-

that the barb 506 may either be positioned in front of pilot needle 154 by an amount sufficient to redirect barb 506 into the opposite direction or pilot needle 154 may advance into the corresponding aperture 152 to a depth at which the redirection of barb 506 upon the entry to aperture 152 will be sufficient to redirect barb 506 into the opposite direction. Once redirected and positioned in line with the second skive, barb 506 is advanced in the opposite direction by pilot needle 156 and through the skin tissue on the opposite side of the vertical interface 51 as pilot needle 156 is withdrawn. Once barb 506 emerges from the dermal tissue, attachment flap 504 may be bent so that barb 506 may be pushed through slot 508, thus securing fastener 500 in a loop and bilaterally capturing both sides of the skin opening 50. It will also be appreciated that attachment flap 504 may be replaced by suitable structure on flexible body 502 for engaging a suture. A suture lock may then be used to secure the suture to barb 506, completing the bilateral capture. In this embodiment described herein, the skives are created simultaneously and the fastener 400 is inserted sequentially into each corresponding skive from an opposite direction. Alternatively, a single U-shaped needle could be utilized in place of pilot needles 154, 156 and both the skives and fastener could be created and inserted sequentially. Numerous other combinations of bilateral creation of skives and insertion of fasteners are contemplated by scope of the present invention.

As described herein, the fastener is oriented so that a working plane defined by the flexible body 502 of fastener 500 is substantially parallel to a plane generally defined by exterior surface 55 of epidermal layer 54, and transverse to vertical interface 51. Those of skill in the art will appreciate, however, that the working plane of fastener 500 could also be oriented substantially orthogonal, or oblique, with the plane generally defined by exterior surface 55 while remaining in a transverse orientation with respect to vertical interface 51. Those of skill in the art will also appreciate that other bilateral capture mechanical fastening systems wherein the

-26-

target tissue zones are penetrated by a fastener in sequential fashion are possible within the scope of the present invention. For instance, a semi-circular, oval, or spiral fastener may be advanced sequentially through target tissue zones 70 on each side of vertical interface 51 using a mechanism that imparts a rotational motion to the fastener, but without causing interdigitation or overlapping of skin across vertical interface 51. The mechanism may have means for creating a semi-circular, oval or spiral skive through which the fastener may be advanced, or the fastener itself may be formed from sufficiently rigid material and have a sharpened point so as to be capable of creating a skive as it passes through the skin. In another alternative embodiment providing a sequential bilateral capture motion, a fastener is provided having a cross-member connecting two legs wherein the legs are staggered so that when the fastener is advanced into the skin in a linear fashion, one of the legs precedes the other. In still another embodiment, two straight fasteners comprising a shaft portion with skin-engaging barbs are provided. These fasteners are oriented in opposite directions on either side of the vertical interface 51, and are sequentially advanced through respective skives by an applicator assembly allowing a reversible motion.

In one embodiment, as shown in Fig. 34, a tab or other similar guiding structure 167 projects from an exposed portion of anvil portion 140 to serve as a reference guide to locating the external surface of the skin against such guiding structures. Most preferably, this guiding structure 167 is adapted to mate with a corresponding pair of surface guiding features 169 on the internal surface of arms 302, 304 of the tissue manipulator assembly 300 so as to provide both a tactile and visual indication of the appropriate positioning of the applicator 100 and tissue manipulator 300 relative to the vertical interface 51 of the tissue opening 50. Preferably, the guiding structure 167 and guiding features 169 combine to force the applicator 100 to stay laterally centered about the vertical interface 51 and to stay properly positioned both horizontally

-27-

and vertically. Alternatively, visual indicators and/or an exterior platform-like structure around the exterior of driving head 140 may be provided to assist the user in proper positioning of the applicator assembly 100 and the tissue manipulator assembly 300.

Figs. 35 and 36 show an alternate embodiment of applicator assembly 100 and tissue manipulator assembly 300 in which both manipulator surfaces 318 and concave areas 150 are semi-spherically shaped to provide guiding structure in both horizontal and vertical orientations as the tissue is compressed by the tissue manipulator 300 into the applicator 100. In this embodiment, there are no inward projections 320 shown for capturing the tissue as the application of pressure to the ball-like tips 318 provides both the capture and compression forces imparted to the tissue. Areas 150 on the applicator 100 are semi-spherical in shape to mate in more than one orientation with the ball tips 318, rather than being merely concave to align the tissue in a single orientation.

Fig. 37 shows another alternate embodiment of applicator assembly 100 in which the fasteners 400 are inserted obliquely into the tissue along the vertical interface 51. In this embodiment, the penetrating needles 152, 154 are oriented obliquely downward relative to the horizontal and the distance $d1$ on the driving head 140 is reduced. An upper projection 167 extends on top of the vertical interface 51 of the opening 50 to serve as a guide and the aperture 141 between upper projection 167 and the driving head 140 is positioned to require less rotational movement of the applicator assembly 100 in the plane of the vertical interface 51 when the tissue is being positioned in the driving head 140 or the applicator assembly 100 is being positioned for insertion of a subsequent fastener 400. One advantage of the oblique orientation of the fasteners 400 along the vertical interface 51 of opening 50 is that the effective spacing between backing members 408 of adjacent fasteners 400 is reduced, thereby affording the opportunity to increase the resulting holding pressure that can be applied across the vertical

-28-

interface 51 to resist tearing by being able to insert more fasteners per longitudinal distance of the opening 50.

Fig. 38 shows another embodiment of the present invention in which the tissue manipulator 300 and the applicator assembly 100 are integrated together into a single handheld surgical instrument 600. In this embodiment, a manual trigger 200 is used to activate first the lateral compression operation of the arms 302, 304 of the tissue manipulator assembly 300 and then is further depressed to engage the delivery mechanism 128. A force translation mechanism 602 inside the handle 110 in the form of a cam, wedge or similar arrangement is first engaged by the depression of the trigger 200. Further depression of trigger 200 then causes delivery mechanism 128 to be actuated. It will be appreciated that a single handheld surgical instrument 600 integrating the structures of both the applicator assembly 100 and the tissue manipulator assembly 300 could be arranged and operated in a number of ways. For example, two trigger actuators could be used instead of one two-stage actuator. Instead of arranging the tissue manipulator assembly 300 and the applicator assembly 100 inline in the same orientation, the two assemblies 300 and 100 could be arranged to face each other in the longitudinal orientation.

An alternative embodiment of a hand-held surgical instrument 700 utilizing a top-down approach, as opposed to previously described bottom-up approaches is depicted in Figs. 40, 41, 42, 43, and 44. Hand-held surgical instrument 700 comprises a handle assembly 702, a tissue manipulator assembly 704 and an applicator assembly 706. Handle assembly 702 has a proximal end 708 and a distal end 710. Handle assembly 702 further comprises a gripping portion 712 and a mounting portion 714. Handle assembly 702 preferably is constructed using a first handle body 716 and a second handle body 718. First handle body 716 includes a pair of hollow projections 720a, 720b. Second handle body 718 includes a pair of through bores 722a, 722b positioned to align with hollow projection 720a, 720b. In addition, first handle body 716

-29-

includes a bore 724 that aligns with a throughbore 725 located on second handle body 718. First handle body 716 also includes another bore 726 aligned with a throughbore 727 on second handle body 718. First handle body 716 and second handle body 718 are assembled into handle assembly 702 using fastening means 721, most typically screws. Fastening means 727 are used to engage first handle body 716 and second handle body 718 at hollow projection 720a and throughbore 722a, hollow projection 720b and throughbore 722b and at bore 726 and throughbore 727. Both first handle body 716 and second handle body 718 include a mounting bore 728 presented within a mounting recess 730. Mounting bore 728 and mounting recess 730 accommodate a spring assembly 731. Located at proximal end 708 of both first handle body 716 and second handle body 718 is a pair of projections 732a, 732b. Projections 732a and 732b include projection bores 734a and 734b. Both first handle body 716 and second handle body 718 include an external mounting surface 740 including a mounting bore 742 and a mounting pin 743.

Tissue manipulator assembly 704 in this embodiment preferably comprises a trigger 750 having a biasing end 752 and a mounting end 754. Mounting end 754 includes an attachment block 756. Attachment block 756 includes an attachment surface 758 having a cylindrical groove 760. Attachment block 756 further comprises an attachment recess 762. A notch 763 is also present within attachment block 756. A pair of opposed attachment walls 764a, 764b define attachment recess 762 along with attachment surface 758. A pair of opposed posts 766a, 766b are mounted on attachment walls 764a, 764b. Also present on the exterior of attachment walls 764a, 764b are a pair of bores 768a and 768b.

Tissue manipulator assembly 704 further includes a pair of opposed tissue forms 770a and 770b. Tissue form 770b is further depicted in Figs. 45 and 46, though it is to be understood that tissue form 770a includes the same features as tissue form 770b but in a mirror-image

-30-

arrangement. Tissue forms 770b includes an attachment end 772 and a gripping end 774. Attachment end 772 includes an opening 776 having a pair of opposed and aligned attachment bores 778, 778b. Tissue form 770b further includes a mounting bore 780, a post bore 782, and a limit bore 784. Limit screw 786 rotatably inserts into limit bore 784. On the exterior of tissue forms 770a, 770b is located a guide projection 788. Grasping end 774 is defined by an interior surface 790 and an exterior surface 792. Interior surface 790 is further defined by a proximal jaw 794, a distal jaw 796, an arcuate recess 798, and a bottom lip 800.

Applicator assembly 706 preferably includes an applicator trigger 802. Applicator trigger 802 includes a biasing end 804, a driving end 806, and a rotational through bore 808. A fulcrum member 810, depicted as a screw, slidably inserts through throughbore 725, throughbore 808 and into bore 724. Fulcrum member 810 allows for rotational travel of applicator trigger 802 as well as providing additional fastening strength between first handle body 716 and second handle body 718. Driving end 806 includes a tip 812. Applicator assembly 706 further includes an insertion block 814 more clearly depicted in Figs. 47, 48 and 49. Insertion block 814 includes an attachment end 816 and an insertion end 818. On the top of insertion block 814 is a hollow channel 820. A pair of attachment bores 822a, 822b on one side of hollow channel 820 are in alignment with a pair of attachment bores 824a, 824b present on the other side of hollow channel 820. Insertion block 814 also includes a pair of alignment bores 823a, 823b. Finally, insertion block 814 includes another pair of post bores 825a, 825b to accommodate a rotation post 827. Insertion end 818 is defined by an insertion head 826. Present on either side of insertion head 826 is an arcuate capture zone 828a, 828b. While insertion head 826 is depicted with a single, arcuate capture zone 828a, 828b on each side, it will be recognized that insertion head 826 could include multiple arcuate capture zones on each side. Within both capture zones 828a, 828b is an alignment indicator 830. The alignment indicator could include a bore or horizontal ledge. An

-31-

insertion cavity 831 and a delivery cavity 832 define a continual opening extending from attachment end 816 to insertion end 818. An attachment slide 833 is dimensioned to fit within insertion cavity 831 and delivery cavity 832. Attachment slide 833 includes an attachment cavity 834 defined by a pair of cavity walls 836a, 836b. An insertion slide 838 is also
5 dimensioned to fit within insertion cavity 831 and delivery cavity 832. Insertion slide 838 comprises a pair of piercing members 840a, 840b. Piercing members 840a, 840b each include an internal arcuate section 842. Piercing members 840a, 840b are connected via a backspan 844.

Surgical instrument 700, as described is a single shot design in which a single bioabsorbable fastener 1010, as depicted in Figs. 50 and 51, and as further described in
10 concurrently filed U.S. Patent Application entitled, "Dynamic Bioabsorbable Fastener For Use In Wound Closure," filed June 25, 2003, which is commonly assigned to the assignee of the present application and is hereby incorporated by reference in its entirety. Fastener 1010, as shown in Fig. 50, comprises a backspan 1012 operably connecting a pair of arms 1014a, 1014b. As depicted, fastener 1010 has a diameter 1013 that is consistent throughout backspan 1012 and
15 arms 1014a, 1014b. Arms 1014a, 1014b each preferably include a rounded tip 1016a, 1016b connected to an internally projecting cleat 1018a, 1018b. Fastener 1010 includes an exterior surface 1020 and an interior surface 1022. Interior surface 1022 as defined by backspan 1012, arms 1014a, 1014b and cleats 1018a, 1018b defines an internal tissue capture zone 1024. Each cleat 1018a, 1018b includes an insertion face 1026, a cleat tip 1028 and a rear surface 1030.
20 Rear surface 1030 intersects arms 1014a, 1014b defining a capture area 1032a, 1032b. Each arm 1014a, 1014b of fastener 1010 has an insertion width 1034 which is defined across the widest width across arm 1014a and cleat 1018a or arms 1014b and cleat 1018b. Generally, fastener 1010 is dimensioned to fit between piercing member 840a, 840b and backspan 844. Fastener 1010 is positioned such that the arms 1014a, 1014b reside within the internal arcuate sections

-32-

842 as depicted in Fig. 52. In an alternative embodiment of fastener 1010 depicted in Fig. 51, the diameter 1013 can be proportioned throughout the backspan 1012 and arms 1014a, 1014b to provide desired strength levels without affecting the interaction of fastener 1010 and piercing members 840a, 840b.

5 Preferably, surgical instrument 700 is used in a through-and-through bilateral tissue fastening technique 860 for bilateral fastening of dermal tissue. The through-and-through bilateral fastening technique 860 is depicted in Figs. 57, 58, 59, 60, 61, 62 and 63. While the through-and-through procedure is described with reference to closure of a skin wound, one of skill in the art will recognize that the through-and-through procedure can be effectively applied
10 in other applications involving closure of tissue openings such as fascia, internal organs, vessels and vasculature, or with tissue attachments including skin grafting, bladder and other anatomic tissues.

Generally, a first step of the through-and-through bilateral fastening technique 860 is to load fastener 1010 between piercing member 840a, 840b and backspan 844. As depicted in Fig.
15 53, fastener 1010 resides snugly within internal arcuate sections 842. As shown in Fig. 54, piercing member 840a, and corresponding piercing member 840b, have a piercing cross-section 862. Similarly, cleat 1018a, and corresponding cleat 1018b, have a cleat cross-section 864 as shown in Fig. 55. Fastener 1010 is specifically designed such that the insertion width 1034 exceeds the piercing cross-section 862. As such, cleats 1018a, 1018b will protrude inwardly
20 from piercing members 840a, 840b, as illustrated in Fig. 53.

Once surgical instrument 700 has been loaded with fastener 1010, insertion head 826 is inserted into and positioned within a tissue wound 862 having a pair of opposed sides 864a, 864b. Surgical instrument 700 should be in an open disposition 866, as shown in Fig. 56, in which the tissue forms 770a, 770b are substantially spaced apart from insertion head 826. Using

-33-

a grasping device 867, most typically being a standard surgical forceps, as depicted in Fig. 57, a medical professional grasps the opposed sides 864a, 864b, and places the opposed side 864a, 864b in proximity to insertion head 826 in an everted disposition 869 as shown in Fig. 58. At this point, opposed side 864a is positioned within capture zone 828a while opposed side 864b is positioned within capture zone 828b. Using alignment indicator 830, a medical professional can properly position opposed sides 864a, 864b with respect to the vertical height of capture zones 828a, 828b as shown in Fig. 59. When properly positioned, the dermal layer 56 of opposed sides 864a, 864b is in contact with the surface of capture zones 828a, 828b.

After opposed sides 864a, 864b are properly positioned within capture zones 828a, 828b, the medical professional biases trigger 750 in an upward direction causing tissue forms 770a, 770b to simultaneously close upon opposing sides 864a, 864b within tissue zones 828a, 828b, as shown in Fig. 60. Surgical instrument 700 is referred to being in a capture disposition 871. Capture disposition 871 is accomplished by directing trigger 750 in an upward direction causing trigger 750 to rotate about rotation post 827. Rotation post 827 operably joins trigger 750 and insertion head 814 in conjunction with post bores 825a, 825b, cylindrical groove 760 and bores 768a, 768b. As trigger 750 is biased upward, mounting end 754 travels in a downward arc causing opposed posts 766a, 766b to move downward and contact guide projection 788 on tissue forms 770a, 770b. This causes tissue forms 770a, 770b to rotate in a downward direction around mounting pin 743 such that the interior surface 790 of tissue forms 770a, 770b is in close proximity to capture zones 828a, 828b. As tissue forms 770a, 770b rotate downwardly, the bottom lip 800 on interior surface 790 prevents tissue, especially the elastic dermal layer 56, from escaping out the bottom of capture zones 828a, 828b. Due to precise dimensioning of insertion head 826 and tissue forms 770a, 770b, the target tissue zone 70 as previously described, is presented within both opposing sides 864a, 864b. In addition, the combination of proximal

-34-

jaw 794 and distal jaw 796 on tissue forms 770a, 770b, grasp and stretch opposed sides 864a, 864b causing opposed sides 864a, 864b to be held tightly between insertion head 826 and tissue forms 770a, 770b to further reduce the potential for perforating the epidermal layer 54 of opposed sides 864a, 864b, as depicted in Fig 61.

5 Once the opposed sides 864a, 864b are captured within insertion head 826 and tissue forms 770a, 770b, the medical professional directs biasing end 804 of applicator trigger 802 in a distal direction as shown in Fig. 62. As biasing end 804 travels rearward, trigger 802 rotates about fulcrum member 810 causing tip 812 on driving end 806 to travel in a proximal direction. Tip 812, positioned within attachment cavity 834, contacts cavity wall 836a causing attachment
10 slide 833 to move in a proximal direction through delivery cavity 832. Attachment slide 833 abuts insertion slide 838 causing insertion slide 838 to also move in a proximal direction through delivery cavity 832. As insertion slide 838 moves in a proximal direction, piercing members 840a, 840b are advanced sequentially out of delivery cavity 832, into capture zones 828a, 828b, into target tissue zones 70 of opposed sides 864a, 864b and into insertion cavity 831. As
15 piercing members 840a, 840b are advanced proximally, fastener 1010 is simultaneously advanced out of delivery cavity 832, into capture zones 828a, 828b, into target tissue zones 70 of opposed sides 864a, 864b and into insertion cavity 831 as shown in Fig. 52. As previously described, insertion width 1034 exceeds the piercing cross-section 862. Consequently, the holes cut in the target tissue zone 70 by piercing members 840a, 840b must stretch to accommodate
20 insertion width 1034. As cleats 1018a, 1018b are advanced into the holes cut in target tissue zone 70, the holes pierced by piercing member 840a, 840b in dermal layer 56 are forced to elastically stretch past the cleat tips 1028. The dermal layer 56 then rebounds and elastically snaps into capture areas 1032a, 1032b.

-35-

Using application assembly 706, the medical professional directs biasing end 804 of applicator trigger 802 in a proximal direction causing trigger 802 to rotate about fulcrum member 810 causing tip 812 on driving end 806 to travel in a distal direction. Tip 812, positioned within attachment cavity 834, contacts cavity wall 836b causing attachment slide 833 to move in a distal
5 direction through delivery cavity 832. Attachment slide 833 causes insertion slide 838 to also move in a proximal direction such that piercing members 840a, 840b are sequentially withdrawn from insertion cavity 831, target tissue zones 70, capture zones 828a, 828b and into delivery cavity 832. However, fastener 1010 remains within target tissue zones 70 as cleats 1018a, 1018b, prevent fastener 1010 from being withdrawn due to captured dermal layer elastically
10 retained within capture areas 1032a, 1032b. Fastener 1010 remains within tissue wound 862 such that backspan 1012 traverses the gap between opposed sides 864a, 864b with the dermal layers 56 forcibly approximated to promote the biological healing process. Once fastener 1010 has been placed, the medical professional directs trigger 750 in a downward direction causing tissue forms 770a, 770b to rotate upwardly and release opposed sides 864a, 864b such that
15 surgical instrument 700 is back in open disposition 866. The through-and-through bilateral fastening technique 860 is typically repeated along the length of tissue wound 862 resulting in the closure of wound 862, as depicted in Fig. 63.

Another alternative embodiment of a handheld surgical instrument 900 is depicted in Figs. 64-68. Handheld surgical instrument 900 comprises a body assembly 902, a trigger
20 assembly 904, a tissue manipulation assembly 906, an applicator assembly 908, and a fastener assembly 909. Body assembly 902 comprises a molded housing 910 connected via a plurality of fastening members 912. Molded housing 910 includes a proximal end 914 and a distal end 916. Molded housing 910 further includes a bottom opening 918.

-36-

Trigger assembly 904 comprises a trigger 920, a manipulation bore 924, a ratchet member 925, an interface channel 926 and a top surface 928. Top surface 928 includes an upper engagement portion 930. Upper engagement portion 930 interfaces with a spring assembly 932.

Tissue manipulation assembly 906 comprises a pair of connecting arms 934a, 934b and a pair of tissue forms 936a, 936b. Tissue forms 936a, 936b include a grasping portion 937 substantially similar to tissue forms 770a, 770b, which have been previously described. On an exterior surface of tissue forms 936a, 936b is a molded guide ramp 938 performing the same function as guide projection 788, as previously described. Each tissue form 936a, 936b includes a pair of mounting bores 940a, 940b.

Applicator assembly 908 includes an advancing assembly 942 comprised of a rotation member 944 and a lever member 946. Rotation member 944 is comprised of a pair of opposed rotation elements 948a, 948b. Each rotation element 948a, 948b includes a distal bore 950, a fulcrum bore 952, and a proximal bore 954. Rotation elements 948a, 948b are then interconnected with a distal connector 956 through distal bores 950, a fulcrum connector 958 through fulcrum bores 952, and a proximal connector 960 mounted through proximal bores 954. Lever member 946 includes distal end 962 and a proximal end 964. A spring assembly 959 is mounted on fulcrum connector 958. Distal end 962 has a channel 966. Lever member 946 includes a fulcrum bore 968 having a fulcrum connector 969. Located at proximal end 964 is a connecting tip 970. Applicator assembly 908 further includes insertion slide 972. Insertion slide 972 comprises a distal end 974 and a proximal end 976. Located at the distal end 974 of insertion slide 972 is an attachment cavity 978 defined by a pair of attachment walls 980a, 980b. At the proximal end 976 of insertion slide 972 is a pair of opposed piercing members 982a, 982b. Piercing members 982a, 982b each include an internal arcuate section 984a, 984b. Piercing members 982a, 982b are operably joined at backspan member 986. Applicator assembly 908

-37-

further includes an insertion head 988. Insertion head 988 includes an arcuate capture zone 990. Throughout the length of insertion head 988 is an insertion cavity 992 dimensioned to accommodate the insertion slide 972.

Fastener assembly 909 in this embodiment comprises a fastener stack 994, consisting of a plurality of bioabsorbable fasteners 1010 previously depicted in Figs. 50 and 51, a fastener housing 996, and a spring feed assembly 998. Fastener assembly 909 can further include a removable locking member 1000. Removable locking pin 1000 allows a surgical instrument 900 to be shipped fully assembled to facilitate ease of use by a physician. Preferably, removable locking pin 1000 prevents spring feed assembly 998 from applying force directly to fastener stack 994 during shipment or storage so that the bioabsorbable fasteners 1010 do not deform after prolonged exposure to the spring force.

Preferably, surgical instrument 900 is used with a through-and-through bilateral tissue fastening technique similar to that of surgical instrument 700 as previously described. One procedural difference being that surgical instrument 900 is a multi-shot design in which a plurality of fasteners 1010 come preloaded, thus eliminating any handloading of individual fasteners 1010. Another procedural difference being that surgical instrument 900 includes trigger assembly 904 which incorporates a two-stage mechanism sequentially operating both the tissue manipulation assembly 906 and applicator assembly 908.

With respect to grasping tissue with tissue manipulation assembly 906, the medical professional squeezes body assembly 902 and trigger assembly 904 causing trigger 920 rotate about ratchet member 925. As trigger 920 enters bottom opening 918, connecting arms 934a, 934b rotate in an opposed direction and contact the molded guide ramp 938 on tissue forms 936a, 936b causing to tissue forms 936a, 936b to rotate about a rotation member coupling

-38-

mounting bores 940a, 940b with body assembly 902. Eventually, tissue forms 936a, 936b rotate to a grasping position on either side of insertion head 988.

Following manipulation of tissue forms 936a, 936b to a grasping position, continual squeezing of body assembly 902 and trigger assembly 904 causes trigger 920 to insert further
5 into bottom opening 918 such that interface channel 926 slides around distal connector 956. As trigger 920 inserts further into bottom opening 918, distal connector 956 reaches an end of interface channel 926 causing rotation member 944 to rotate about fulcrum connector 958 such that proximal connector 960 moves in a downward direction. Downward movement of proximal connector 960 causes channel 966 to move in a downward direction resulting in lever member
10 946 rotating about fulcrum connector 969. As channel 966 moves downward, proximal end 964 moves in a forward direction causing connecting tip 970 to direct insertion slide 972 to advance toward insertion head 988. As insertion head 988 advances, piercing members 982a, 982b and backspan member 986 cooperatively capture a bottom most fastener 1010 from fastener stack 994. Fastener 1010 is advanced through the capture zone 990 and into the target tissue zones 70
15 as previously described with respect to surgical instrument 700.

As trigger 920 is further squeezed and inserted into opening 918, ratchet member 925 releases. As piercing members 982a, 982b retract past fastener stack 994, spring feed assembly 998 advances the bottom most fastener 1010 into position for a future capture by piercing members 982a, 982b. As ratchet member 925 releases, spring assembly 932 interacts with upper
20 engagement portion 930 allowing trigger 920 to return to its original position which in turn caused tissue forms 936a, 936b to release the grasped tissue. In addition, spring assembly 959 causes rotation member 944 to return to its original orientation such that piercing members 982a, 982b are retracted

-39-

Although the present invention has been described with respect to the various embodiments, it will be understood that numerous insubstantial changes in configuration, arrangement or appearance of the elements of the present invention can be made without departing from the intended scope of the present invention. Accordingly, it is intended that the
5 scope of the present invention be determined by the claims as set forth.

-40-

CLAIMS

1. A mechanical method of bilaterally securing skin tissue with a fastener comprising:

approximating a portion of an interior surface of each of two pieces of living dermis tissue along a vertical interface that is generally perpendicular in at least one orientation to an exterior surface defined by epidermis tissue associated with the living dermis tissue without overlapping either interior surface across the vertical interface;

positioning a mechanical apparatus having a driving head portion positioned in the vertical interface and at least partially below the exterior surface and a handle portion positioned at least partially above the exterior surface; and

utilizing the mechanical apparatus to bilaterally drive at least one portion of the fastener through each piece of the living dermis tissue behind the vertical interface and the interior surface of that piece of tissue such that the fastener is positioned below the exterior surface and a portion of the fastener is positioned generally transverse to the vertical interface.

2. The method of claim 1, wherein the fastener includes at least two leg members and a cross-member and wherein the step of utilizing the mechanical apparatus simultaneously bilaterally drives each of the at least two leg members through a corresponding piece of the living dermis tissue.

3. The method of claim 2, wherein the cross-member is the portion of the fastener positioned generally transverse to the vertical interface and wherein the step of utilizing the mechanical apparatus positions a working plane of the fastener defined by the cross-member and two leg members in a horizontal orientation generally parallel in at least one orientation to the

-41-

exterior surface defined by epidermis tissue.

4. The method of claim 1, wherein the fastener includes a portion configurable in a generally U-shaped configuration and wherein the step of utilizing the mechanical apparatus sequentially bilaterally drives the fastener first through one of the pieces of living dermis tissue and then through another of the pieces of living dermis tissue.
5. A system for securing skin tissue comprising:
- at least one fastener;
 - 10 a pair of opposed jaws operable to approximate two pieces of living dermis tissue along an interface without overlapping when the jaws engage the epidermis tissue associated with the living dermis tissue; and
 - a bilateral fastening apparatus including:
 - 15 a driving head having a portion of which is positioned below the epidermis tissue;
 - structure for containing the at least one fastener;
 - a delivery mechanism operably connected to the structure and the driving head to eject the at least one fastener from the driving head so as to bilaterally drive the fastener through each piece of the living dermis tissue behind the
 - 20 interface; and
 - a handle positioned above the epidermis tissue and having a trigger mechanism operably connected to selectively operate the delivery mechanism.
6. The system of claim 5, wherein the fastener has at least two legs extending from a

-42-

backing member and wherein the delivery mechanism simultaneously drives each leg of the fastener through a corresponding piece of the living dermis tissue.

7. The system of claim 5, wherein the bilateral fastening apparatus comprises a single
5 handheld surgical instrument and the pair of opposed jaws are mechanically integrated with the bilateral fastening apparatus.

8. The system of claim 7, wherein the pair of opposed jaws are operably connected to and operated by the trigger mechanism.

10 9. The system of claim 5, wherein the structure of the bilateral fastening apparatus contains a plurality of fasteners and the delivery mechanism delivers the plurality of fasteners while at least a portion of the driving head is continually positioned below the epidermis tissue.

15 10. The system of claim 5, wherein the delivery mechanism includes a pair of pilot needles operably coupled to a sliding mechanism that is pivotally coupled to the trigger mechanism, the pilot needles including structure for containing one fastener.

20 11. The system of claim 10, wherein the driving head includes an anvil portion having a pair of apertures into which a distal portion of the pair of pilot needles are driven.

12. The system of claim 5, wherein the bilateral fastening apparatus further comprises at least one guiding structure that indicates to a user a proper positioning of the fastening apparatus relative to the dermis tissue.

-43-

13. The system of claim 12, wherein the at least one guiding structure comprises a tab projecting from the driving head portion and a pair of guiding structures on an inner surface of the opposed jaws that are adapted to mate with each other. tissue.
- 5 14. The system of claim 5, wherein the pair of opposed jaws further include stop structures that prevent the jaws from closing more than a predetermined distance, the predetermined distance being defined in relation to a width of a pair of skives created by the delivery mechanism.
- 10 15. The system of claim 5, wherein the at least one fastener is made of a material selected from the set consisting of: a bioabsorbable material, a bioresorbable material, a bioerodible material or any combination thereof.
16. A system for securing tissue comprising:
- 15 fastener means for bilaterally fastening two opposing portions of tissue;
means for approximating the two opposing portions of tissue without interdigitation of the opposing portions of tissue; and
means for delivering the fastener means bilaterally into each of the opposing portions of tissue.
- 20
17. The system of claim 16, wherein the tissue is skin tissue and the means for delivering comprises:
- storage means for receiving the fastener means;
head means for positioning an aperture through which the fastener means

-44-

is delivered directly into a dermal layer of the skin tissue;

ejection means operably connected to the storage means and the head

means for ejecting the fastener means from the aperture; and

handle means positioned above the skin tissue for selectively operating the

5 ejection means.

18. A bilateral fastening apparatus that secures two pieces of living tissue through the dermal layer below the associated epidermal layer with a fastener, the apparatus comprising:

10 a driving head having at least a portion of which is positioned below the epidermal layer;

structure that receives the at least one fastener;

a delivery mechanism operably connected to the structure and the driving head to eject the at least one fastener from the driving head so as to bilaterally drive the fastener separately through each corresponding dermal layers; and

15 a handle positioned above the epidermal layer and having a trigger mechanism operably connected to selectively operate the delivery mechanism.

19. The apparatus of claim 18, wherein the at least one fastener has a planar orientation and wherein the driving head is oriented such that the planar orientation of the at least one fastener once ejected is generally horizontal relative to the epidermal layer.

20. The apparatus of claim 18, wherein the at least one fastener has a planar orientation and wherein the driving head is oriented such that the planar orientation of the at least one fastener once ejected is generally oblique relative to the epidermal layer.

-45-

21. A bilateral fastening apparatus that secures two pieces of living tissue through the dermal layer below the associated epidermal layer with a fastener, the apparatus comprising:

storage means for receiving the fastener;

head means for positioning an aperture through which the fastener is delivered in

5 lateral contact with the dermal layer;

ejection means operably connected to the storage means and the head means for ejecting the fastener from the aperture so as to bilaterally drive the fastener separately through each corresponding dermal layers; and

10 handle means positioned above the epidermal layer for selectively operating the ejection means.

22. A mechanical method of bilateral fastening of opposing skin tissue across an opening comprising:

15 utilizing a manipulator apparatus to position the opposing tissue together such that dermal layers are proximate each other at the opening and a pair of spaced apart target tissue zones are presented to a fastening apparatus, each target tissue zone being defined in a plane of each dermal layer generally perpendicular to both a surface of the associated epidermal layer and a longitudinal orientation of the opening;

20 utilizing the fastening apparatus to bilaterally secure the dermal layers by inserting a fastener through each of the target tissue zones while opposing tissue is positioned together in an orientation generally perpendicular to the plane of the target tissue zones.

23. The method of claim 22, wherein each target tissue zone is defined in the plane by a

-46-

rectangle of dimensions less than or equal to 2 mm deep by less than or equal to 20 mm wide on opposite sides of the longitudinal orientation of the opening and at least 0.1 mm below the surface of the associated epidermal layer.

5 24. The method of claim 23, wherein the rectangle has dimensions of 1 mm deep by 10 mm wide.

25. A system for securing skin tissue across an opening comprising:

at least one fastener having at least two legs extending from a backing member;

10 a positioning apparatus that positions tissue on opposite sides of the opening together such that dermal layers are proximate each other at the opening and a target tissue zone is presented, the target tissue zone being defined in a plane of each dermal layer generally perpendicular to both a surface of the associated epidermal layer and a longitudinal orientation of the opening; and

15 a simultaneous bilateral fastening apparatus that engages the target tissue zone presented by the positioning apparatus and bilaterally secures the dermal layers by inserting a unique one of the legs of the fastener through each target tissue zone in an orientation generally perpendicular to the plane of the target tissue zone.

20 26. The system of claim 25, wherein each target tissue zone is defined in the plane by a rectangle of dimensions less than or equal to 2 mm deep by less than or equal to 20 mm wide on opposite sides of the longitudinal orientation of the opening and at least 0.1 mm below the surface of the associated epidermal layer.

-47-

27. The system of claim 26, wherein the rectangle has dimensions of 1 mm deep by 10 mm wide.

28. A bilateral fastening apparatus that secures two pieces of living tissue through the dermal layer below the associated epidermal layer with a fastener having at least two fork members, the apparatus comprising:

tissue manipulating apparatus that positions a portion of each of the dermal layers of each piece of tissue proximate each other such that a pair of target tissue zones are presented, each target tissue zone being defined in a plane of each dermal layer generally perpendicular to both a surface of the associated epidermal layer and a longitudinal orientation of a gap between the two pieces of tissue and spaced apart from the other target tissue zone; and

applicator apparatus that engages the target tissue zone presented by the manipulating apparatus and bilaterally secures the dermal layers by simultaneously inserting a unique one of the forks of the fastener through each target tissue zone in an orientation generally perpendicular to the plane of each target tissue zone.

29. The apparatus of claim 28, wherein the fastener has a planar orientation and wherein the applicator apparatus has a portion of which is oriented such that the planar orientation of the fastener once the forks of the fastener are inserted in each target tissue zone is generally horizontal relative to the epidermal layer.

30. The apparatus of claim 28, wherein the fastener has a planar orientation and wherein the applicator apparatus has a portion of which is oriented such that the planar orientation of the

-48-

fastener once the forks of the fastener are inserted in each target tissue zone is generally oblique relative to the epidermal layer.

31. The apparatus of claim 28, wherein the applicator apparatus further includes at least one
5 guiding structure that positions the applicator apparatus relative to the target tissue zone.

32. A bilateral fastening apparatus that secures two opposing portions of dermal tissue with a fastener having at least two leg members, the apparatus comprising:

10 positioning means for positioning the two opposing portions of dermal tissue proximate each other such that a pair of target tissue zones are presented, each target tissue zone being defined in a plane of each dermal tissue generally perpendicular to both a surface of the associated skin tissue and a longitudinal orientation of a gap between the two pieces of dermal tissue; and

fastening apparatus including:

15 means for engaging the target tissue zone presented by the positioning means; and

means for bilaterally securing the dermal tissue by inserting each of the leg members of the fastener into only one of the target tissue zones in an orientation generally perpendicular to the plane of each target tissue zone.

20 33. A mechanical method of fastening of a pair of opposing pieces of skin tissue across a gap comprising:

utilizing a mechanical apparatus to position a dermal layer of each of the opposing skin tissue together at the gap such that a pair of unique tissue target zones in

-49-

the dermal layer are presented, each tissue target zone being defined in a three dimensional volume of one of the pieces of opposing skin tissue at a depth of between 0.1 mm and 2.0 mm below an exterior surface of the skin tissue, at a width of between 1 mm and 20 mm from an edge of the gap and along a longitudinal length of the gap wherein
5 the depth and width define an insertion plane generally perpendicular to the longitudinal length of the gap;

utilizing a fastening apparatus to secure the dermal layers by inserting a portion of a fastener through the insertion plane into each tissue target zone while the opposing tissue is together with no portion of the fastener above the exterior surface of
10 the skin tissue.

34. The method of claim 33, wherein the fastener is inserted in each tissue target zone in a generally horizontal orientation parallel to the exterior surface of the skin tissue.

15 35. The method of claim 33, wherein the fastener is inserted in each tissue target zone in a generally oblique orientation and parallel to the exterior surface of the skin tissue.

36. A system for securing skin tissue across an opening comprising:

at least one fastener having at least two legs extending from a backing member;

20 a tissue manipulator apparatus that positions tissue on opposite sides of the opening together such that there is a first predetermined distance between exterior surfaces of an epidural layer of the opposite sides; and

a simultaneous bilateral fastening apparatus that engages the dermal layers presented by positioning apparatus and bilaterally secures the dermal layers by inserting a

-50-

unique one of the legs of the fastener through each dermal layer with the legs of the fastener being spaced apart from each other by a second predetermined distance,

wherein the first predetermined distance is between 0.4mm and 1.6mm greater than the second predetermined distance.

5

37. A bilateral fastening apparatus that secures two pieces of living tissue through the dermal layer below the associated epidermal layer with a fastener having a structure that defines an internal capture area, the apparatus comprising:

10 a driving head having a portion of which is positioned below the epidermis tissue and includes opposed tissue receiving structures each defining a space for receiving compressed dermis tissue; and

15 a delivery mechanism operably connected to the driving head to bilaterally drive the fastener through each of the spaces defined by each of the opposed tissue receiving structures such that the fastener captures compressed dermis tissue within the capture area.

38. A bilateral fastening apparatus that secures two opposing portions of dermal tissue with a fastener having at least two leg members, the apparatus comprising:

20 positioning means for positioning the two opposing portions of dermal tissue proximate each other such that there is a first predetermined distance between an exterior surfaces of an epidermal layer of each of the two opposing portions of dermal tissue; and

fastening apparatus including:

means for engaging the dermal tissue presented by the positioning means;

and

-51-

means for bilaterally securing the dermal tissue by inserting each of the leg members of the fastener into only one of the two opposing portions of dermal tissue such that the leg members are spaced apart by a second predetermined distance that is less than the first predetermined distance.

5

39. The apparatus of claim 38, wherein the first predetermined distance is between 0.4 mm and 1.6 mm greater than the second predetermined distance.

40. A tissue manipulator apparatus comprising:

10 a pair of arms operably attached to each other such that a user operably manipulates distal ends of the pair of arms in opposition to each other;

a pair of jaw members, each jaw member resiliently attached to a corresponding distal end of one of the arm and having a pair of inwardly directed projections;

15 structure operably configured on the distal end of each arm and positioned between the corresponding pair of jaw members that defines a manipulator surface for compressing tissue; and

20 a stop mechanism operably attached to at least one of the arms to prevent the manipulator surfaces from closing to more than a predetermined distance, such that when the user operably manipulates the pair of arms in opposition to each other, the jaw members engage tissue with a first force and the manipulator surfaces engage tissue between the jaw members with a second force that is greater than the first force.

41. A bilateral fastening apparatus that secures two pieces of living tissue using a fastener inserted into a pair of pierced openings in a pair of defined target tissue zones, the fastener

-52-

including a pair of arms operably connected at a backspan, each arm further including an inwardly projecting cleat, the apparatus comprising:

5 a tissue manipulation mechanism for defining the target tissue zones, the tissue manipulation mechanism having a pair of opposed tissue forms operable to approximate the two pieces of living tissue along an interface without overlapping when the forms engage the tissue;

10 a delivery mechanism having an applicator head, the applicator head defining a pair of capture zones, each capture zone adapted to interface with one of the tissue forms, the delivery mechanism further including a pair of slidable piercing members adapted to carry the fastener, the piercing members cutting the pierced openings such that each pierced opening stretches over one of the inwardly projecting cleats as the fastener arms are inserted into the pierced openings; and

15 a handle having at least one trigger mechanism adapted to selectively operate the tissue forms and the delivery mechanism.

42. The apparatus of claim 41, wherein the handle includes a single trigger mechanism adapted to sequentially operate the tissue manipulation mechanism to approximate the two pieces of living tissue and subsequently advance the delivery mechanism to deliver the fastener within the target tissue zones.

20 43. The apparatus of claim 41, further comprising a loading mechanism, the loading mechanism comprising a fastener magazine having a plurality of fasteners and a spring member, the loading mechanism adapted to position a fastener for capture by the piercing members.

-53-

44. The apparatus of claim 43 wherein the loading mechanism further comprising a releasable locking member for isolating the fastener magazine and the spring member during transport or storage of the bilateral fastening apparatus.

5 45. The apparatus of claim 41, wherein each tissue form comprises a proximal jaw and a distal jaw adapted to retainably stretch the tissue along the capture zones.

46. The apparatus of claim 41, wherein the applicator head includes at least one guiding member indicating a proper vertical positioning of the tissue with respect to the capture zones.

10

47. The apparatus of claim 41, wherein each tissue form includes a projecting bottom lip to further assist in positioning the two pieces of living tissue within the capture zones.

48. The apparatus of claim 41, wherein the at least one trigger mechanism comprises a
15 ratcheting member to prevent withdrawal of the piercing members prior to placement of the fastener within the pierced openings.

49. The apparatus of claim 41, wherein the target tissue zones are located in a dermal layer below an associated epidermal layer, the tissue forms engaging the epidermal layer to
20 approximate the two pieces of living tissue.

50. A mechanical method for bilaterally securing skin tissue with a through and through technique, the technique practiced with a surgical instrument delivering a fastener, the fastener comprising a pair of arms operably joined at a backspan, each arm further including an inwardly

-54-

projecting cleat, each cleat and arm defining a maximum insertion width, the surgical instrument comprising pair of tissue forms and a pair of piercing members, the method comprising:

5 positioning a pair of opposed sides of a wound such that living tissue of each side is approximated along a vertical interface, the vertical interface generally perpendicular in at least one orientation to an exterior surface of the tissue;

mechanically positioning the pair of tissue forms such that a pair of target tissue zones within the living tissue of each opposed side of the wound are presented to the pair of piercing members;

10 mechanically piercing a pair of apertures with the pair of piercing members, one aperture being pierced in each of the target tissue zones within the opposed sides of the wound, each aperture having an aperture width; and

mechanically inserting the fastener using the piercing members to deliver one arm into each of the apertures, each aperture elastically stretching over the appropriate cleat.

Fig.1

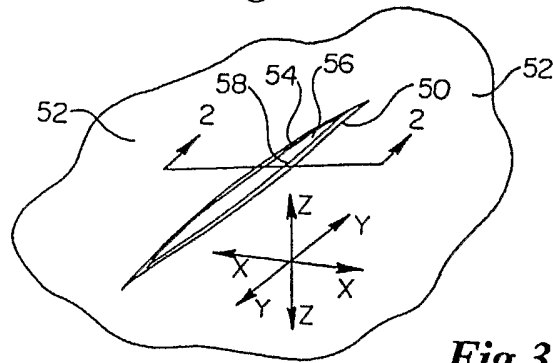

Fig.2

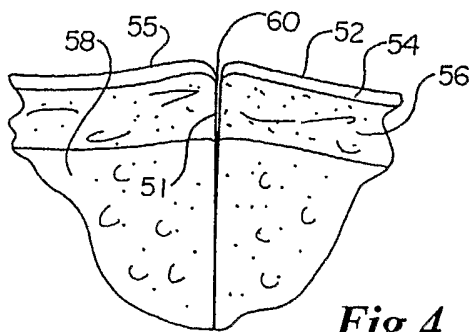

Fig.3

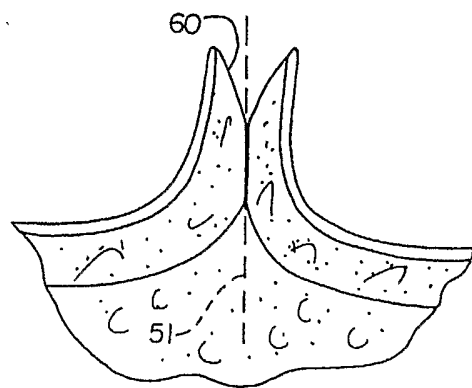

Fig.4

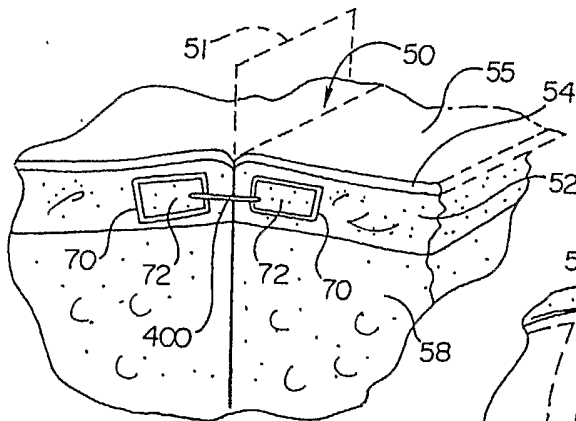

Fig.5

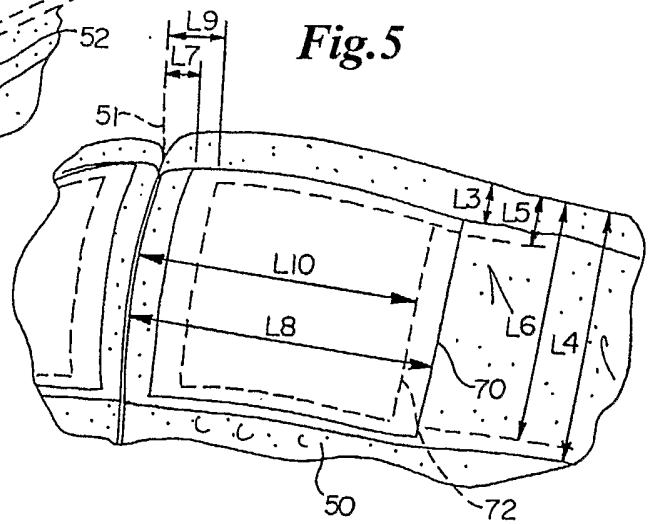

Fig.6

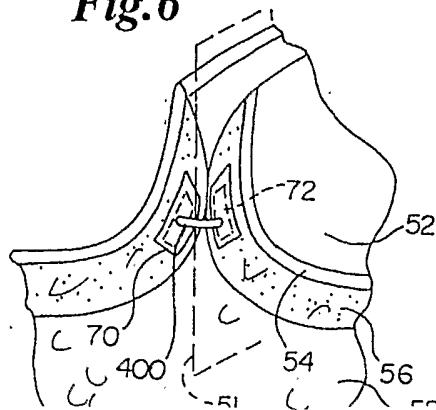

Fig. 7

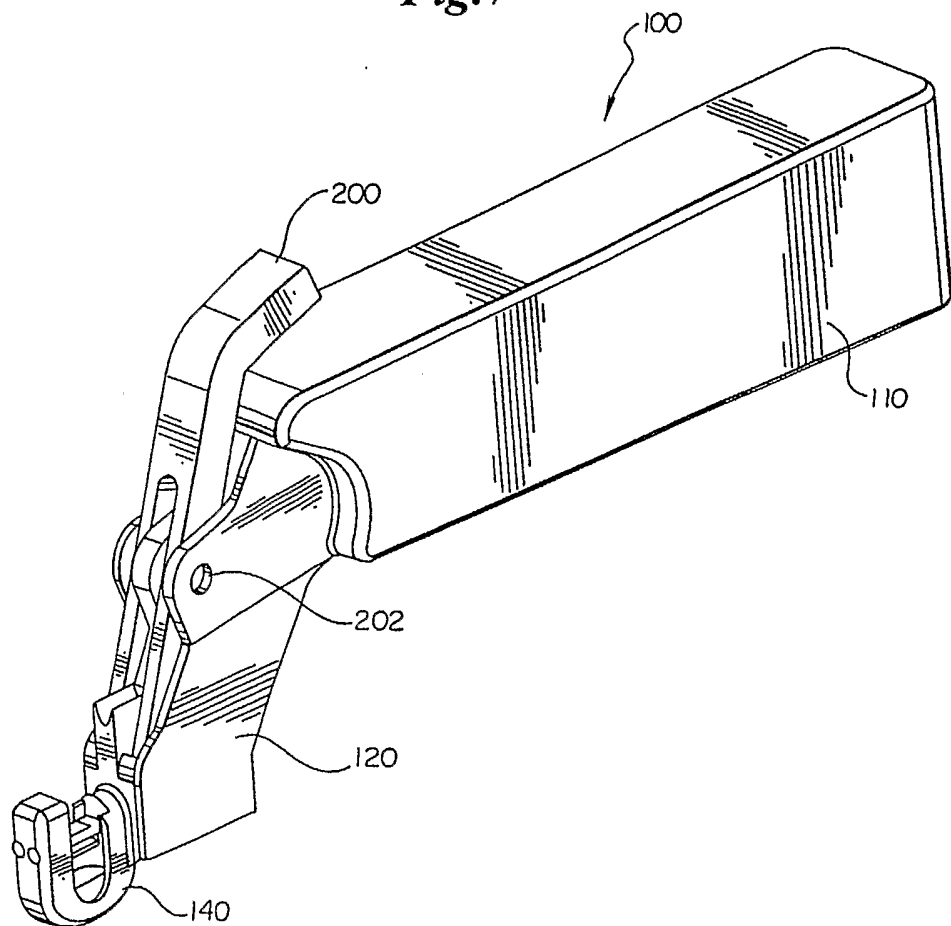

Fig. 8

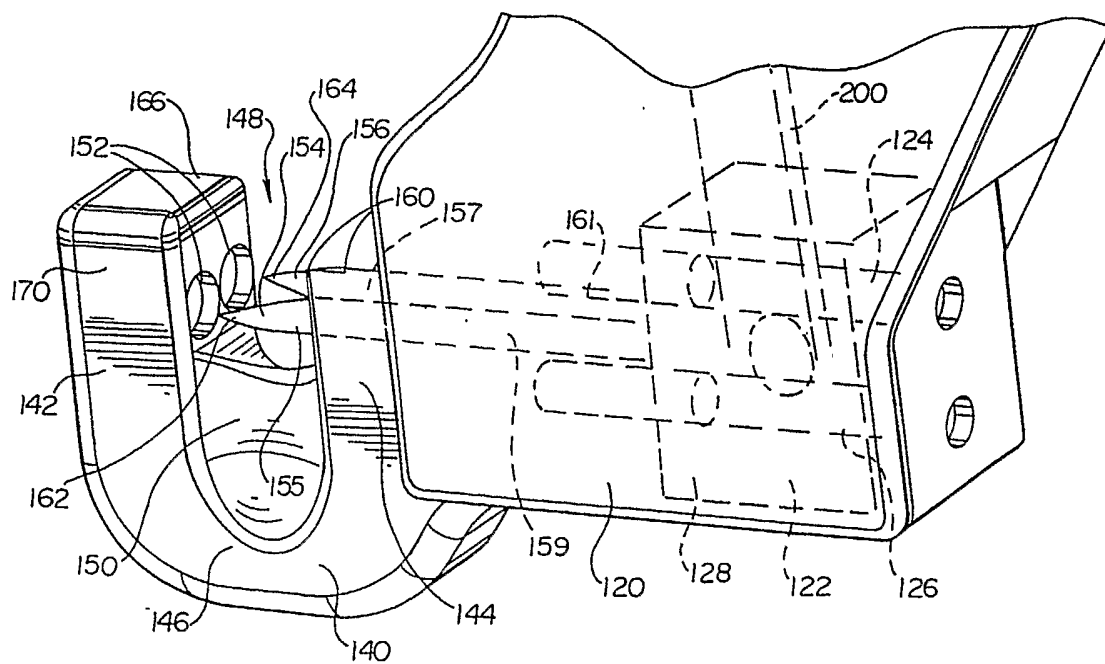

Fig.9

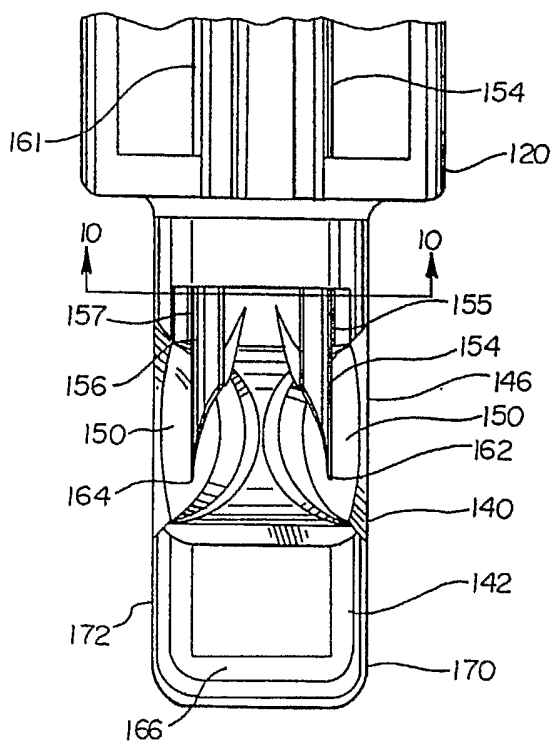

Fig.10

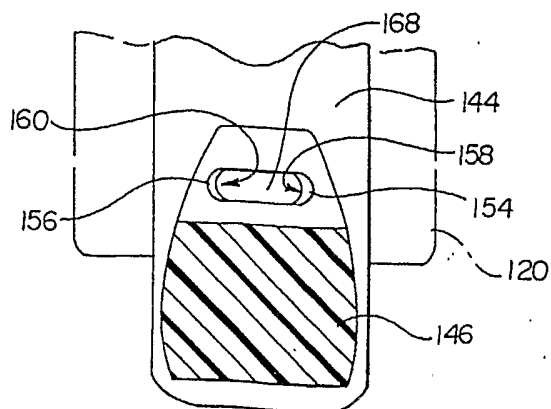

Fig. 11

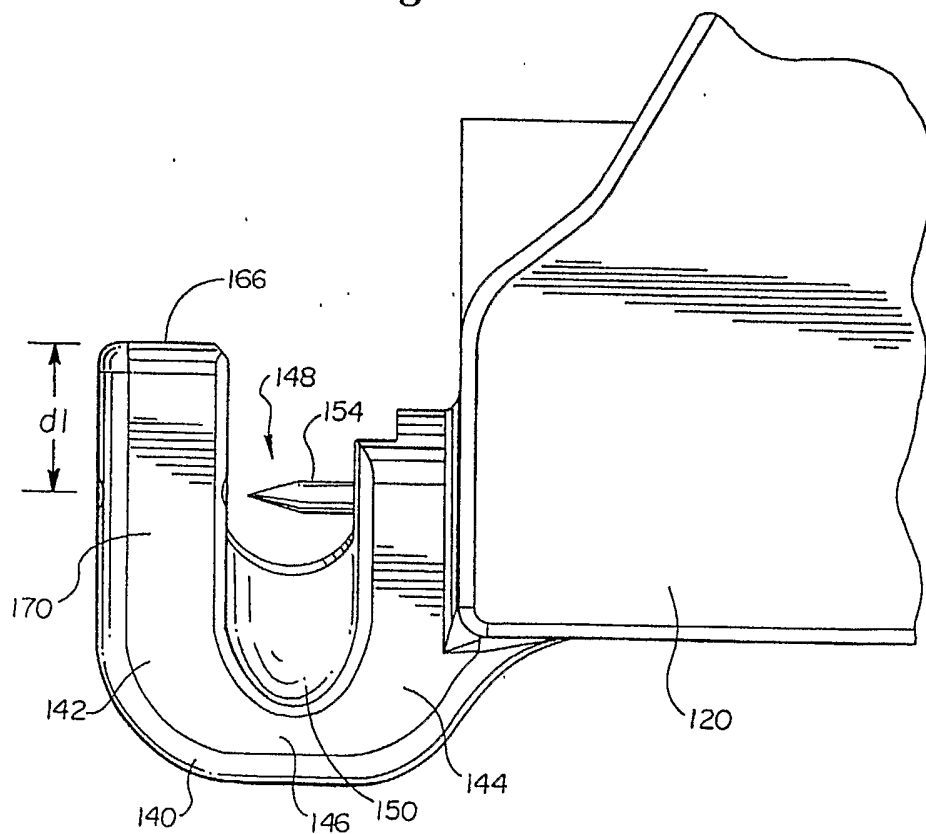
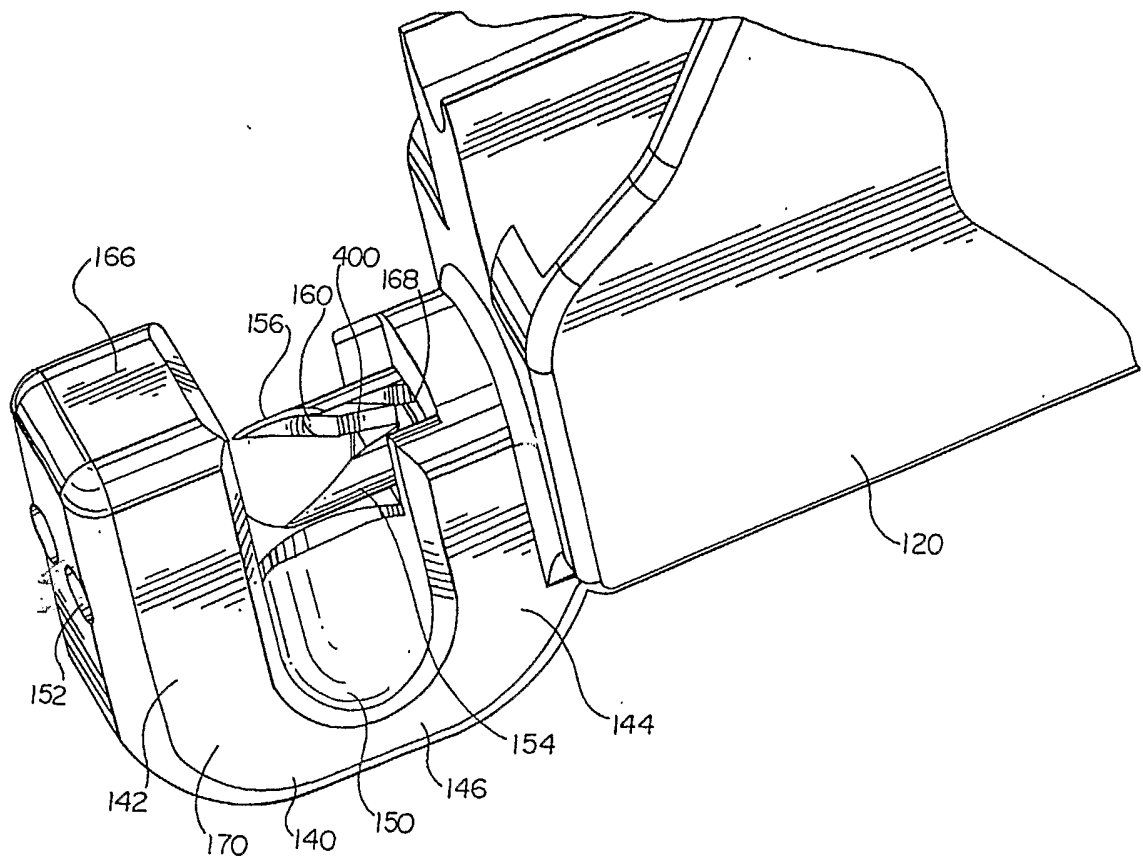
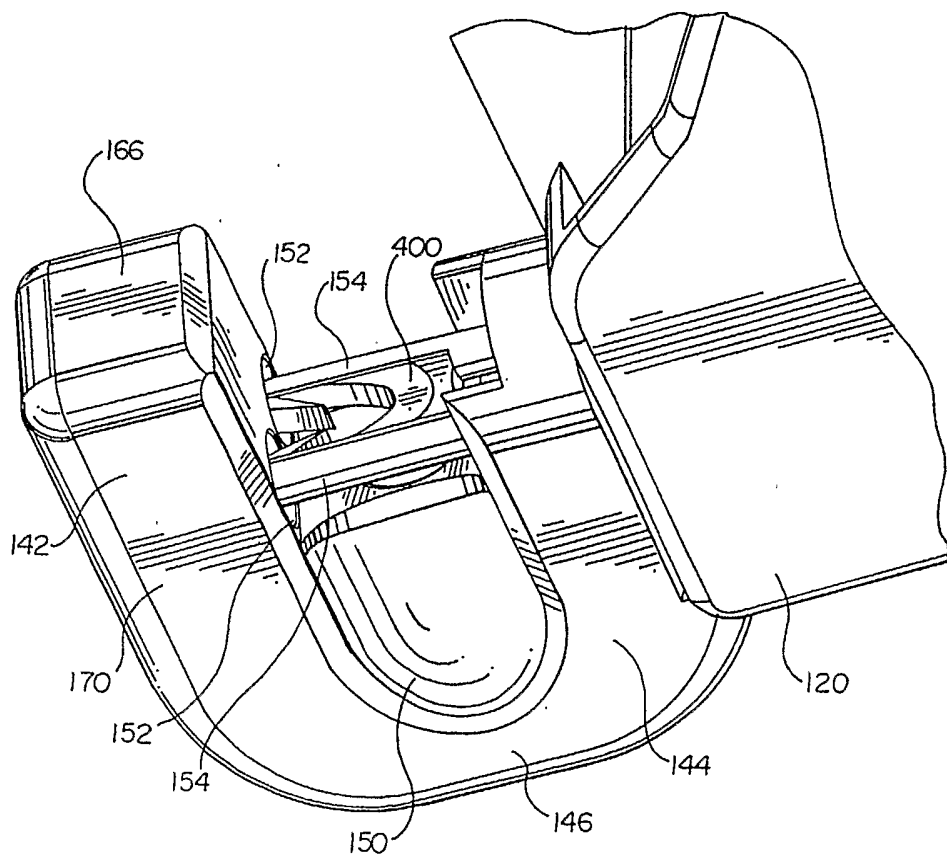

Fig.12



7/51

Fig. 13



8/51

Fig.14

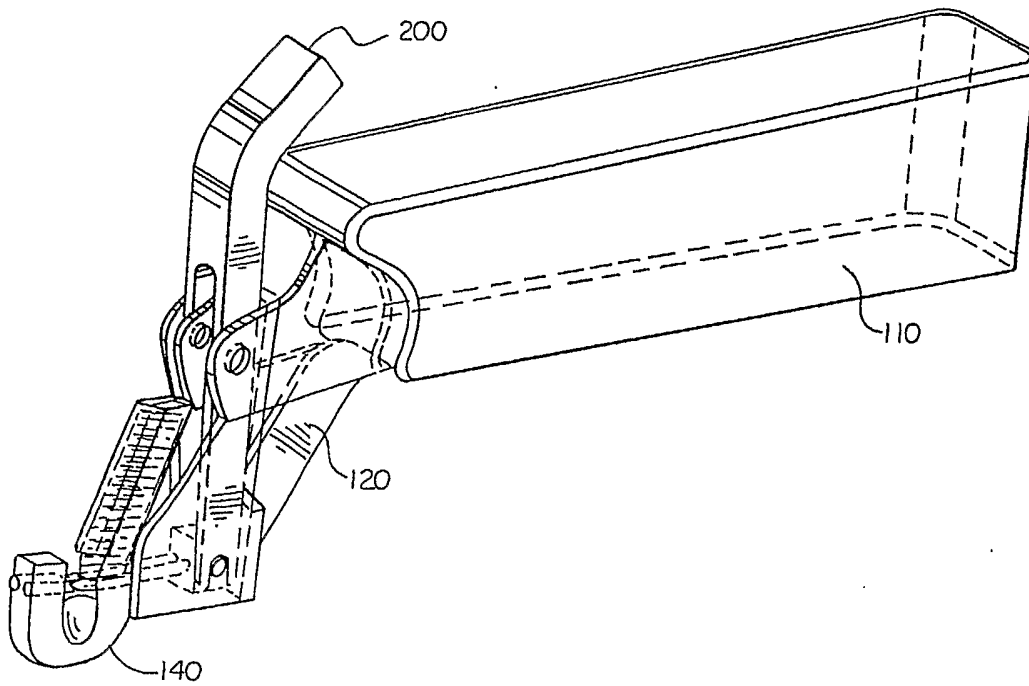

Fig.15

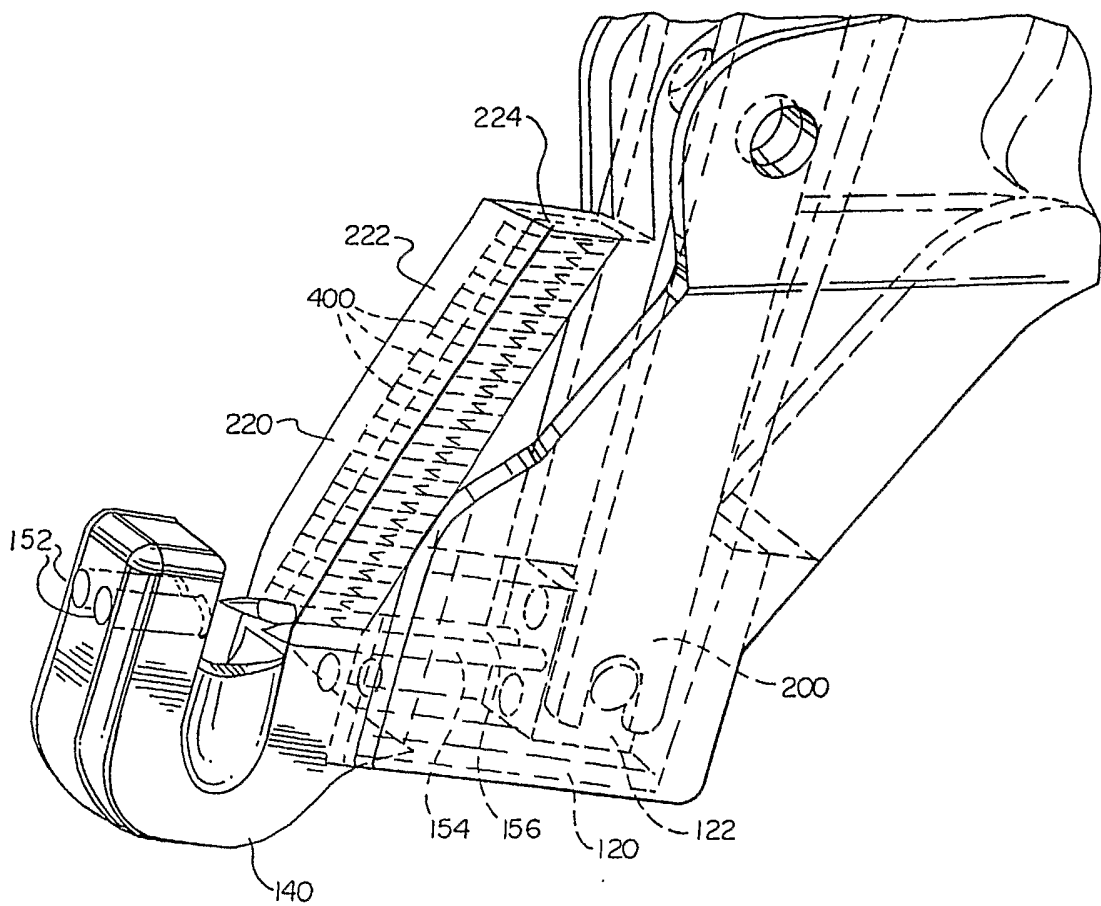

Fig.16

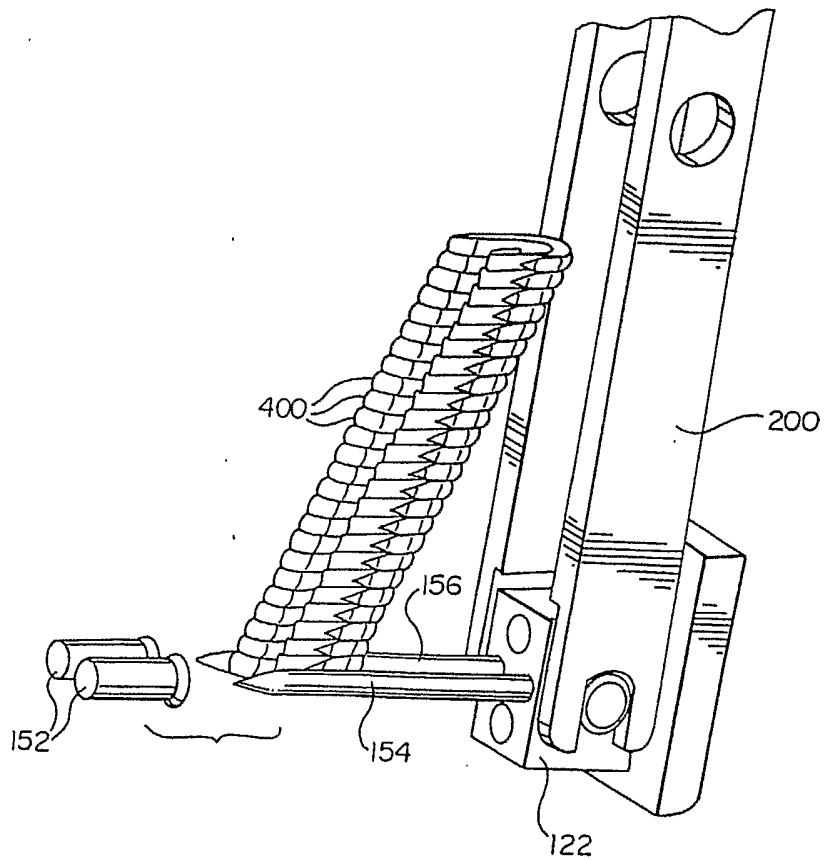
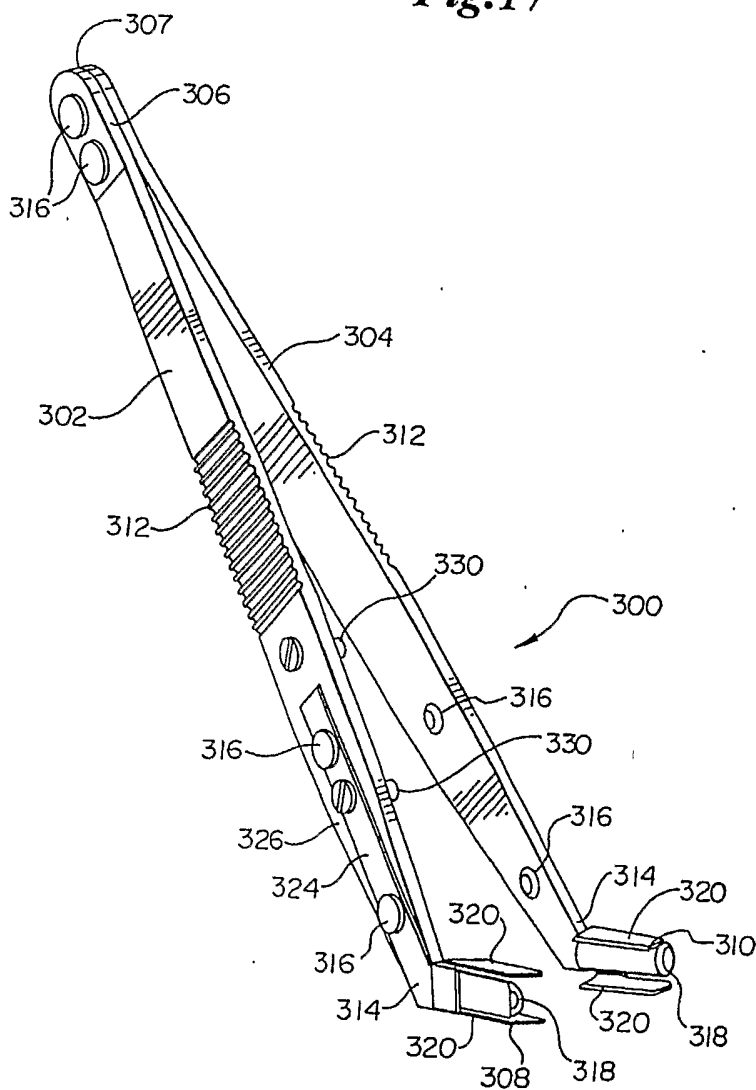
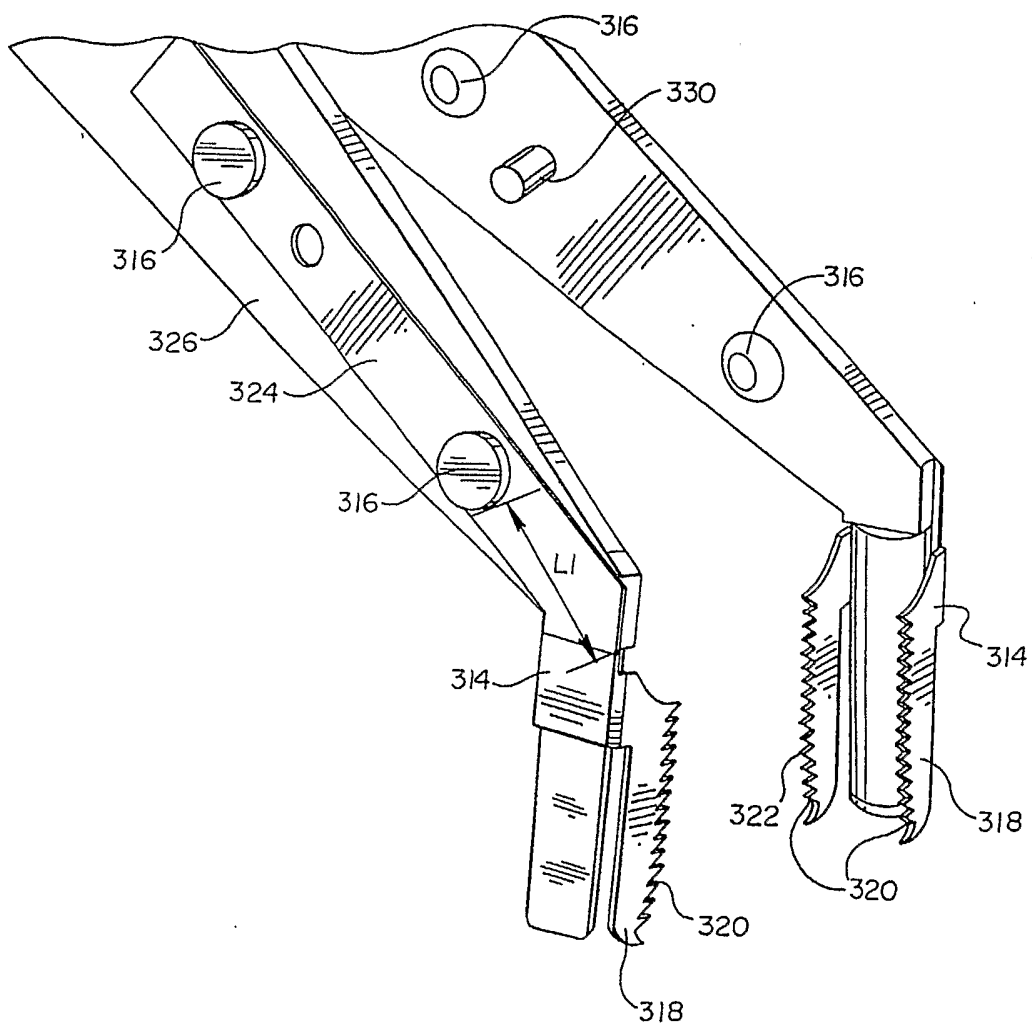

Fig.17



12/51

Fig.18



13/51

Fig.19

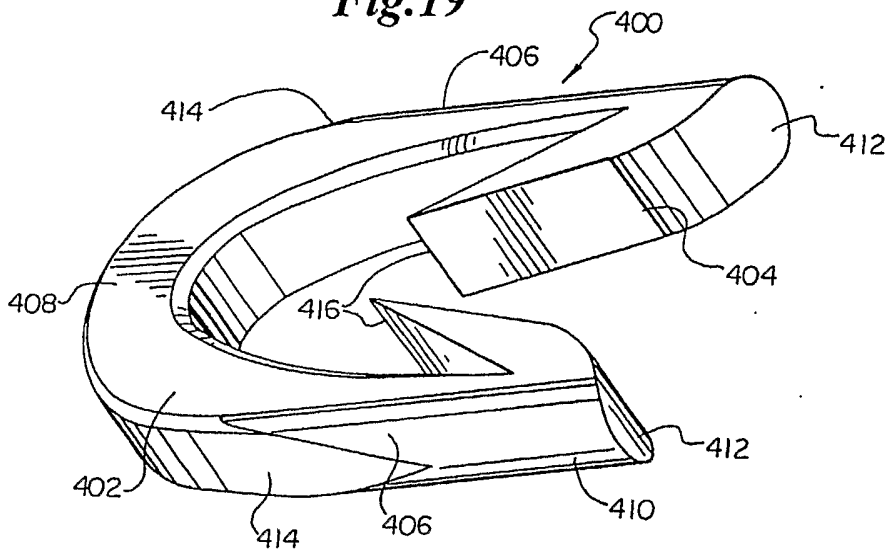

Fig.20

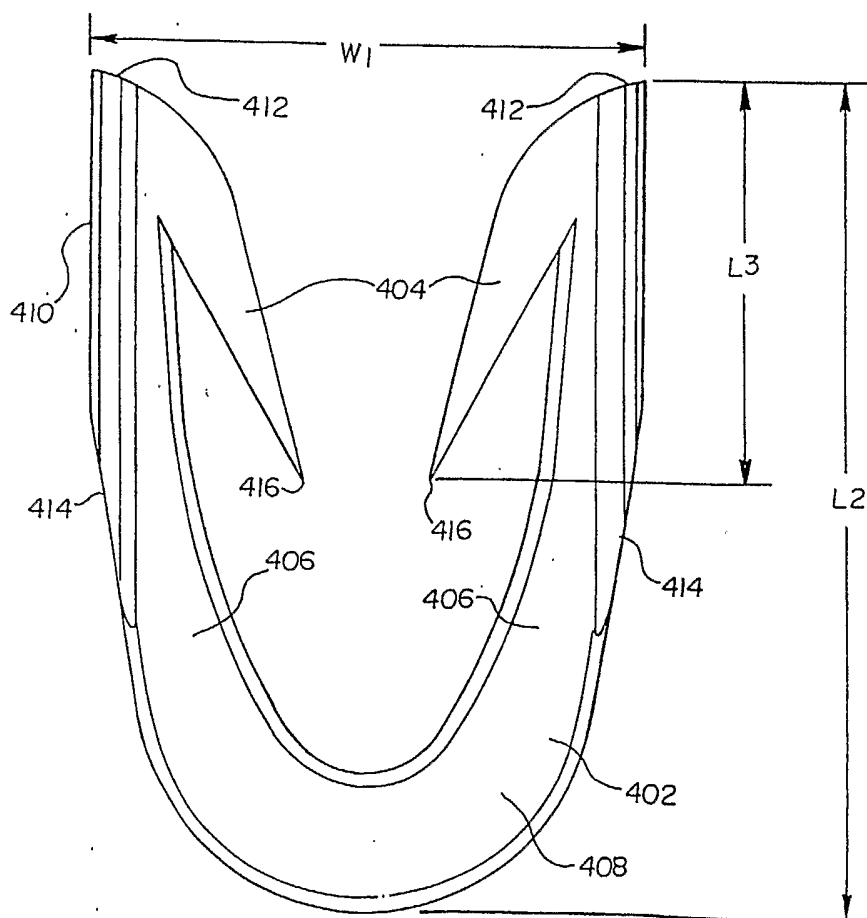

Fig. 21

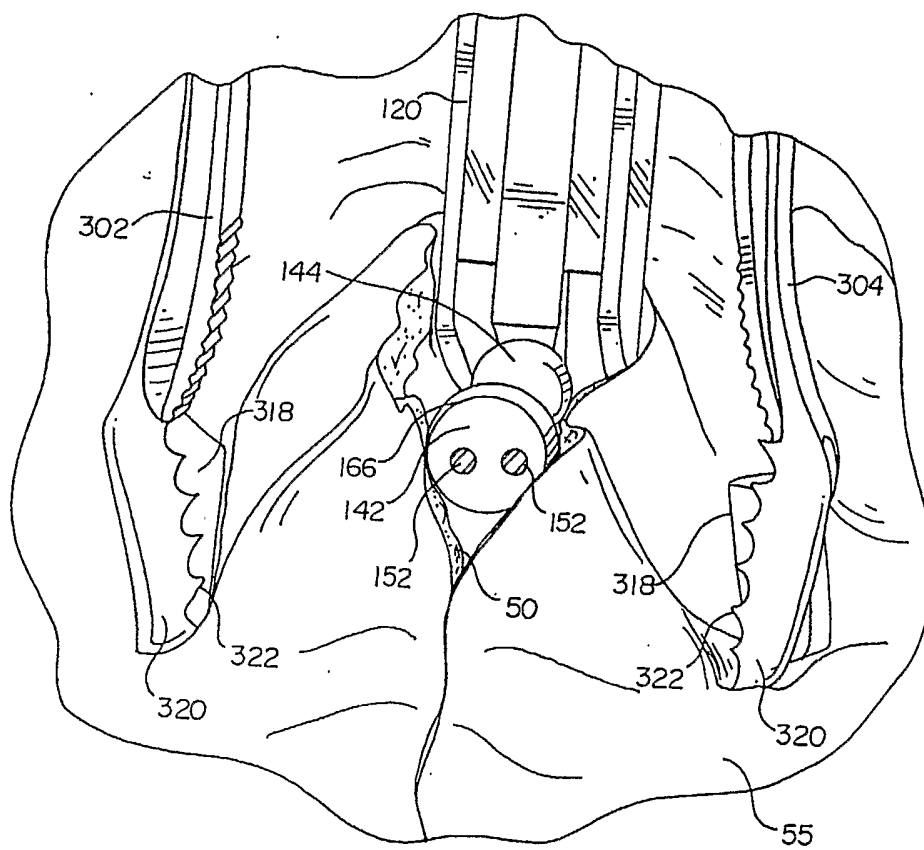

Fig.22

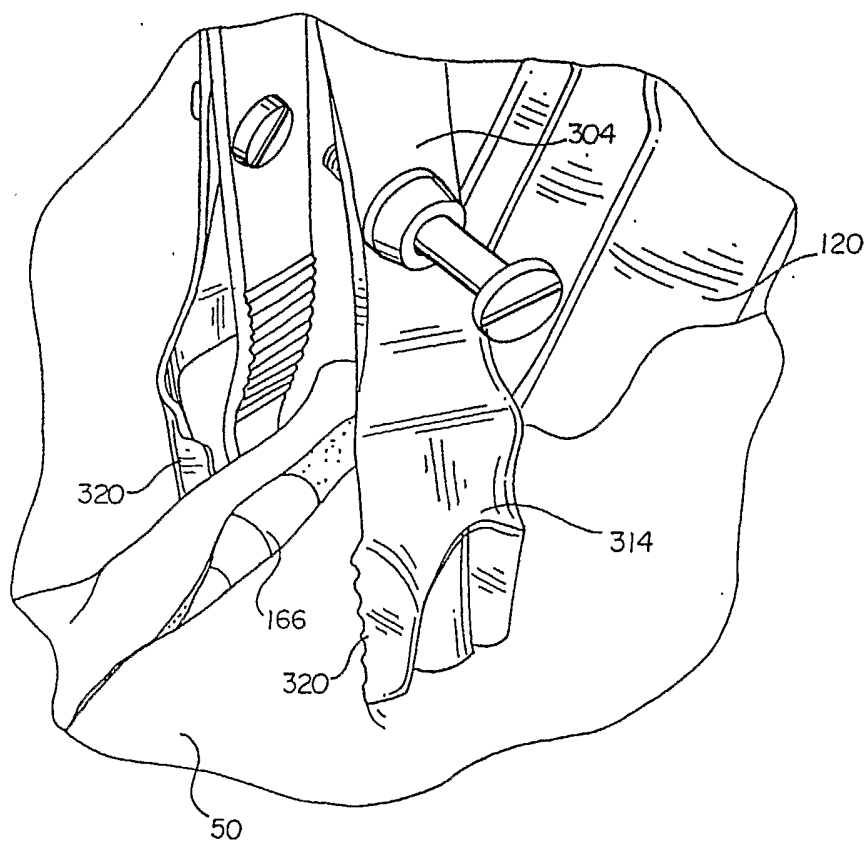

Fig.23

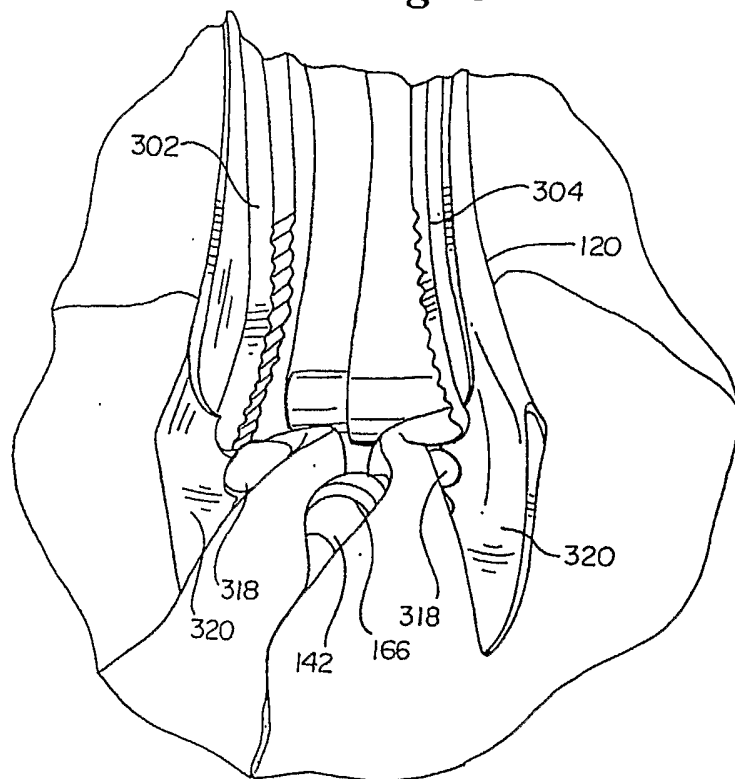
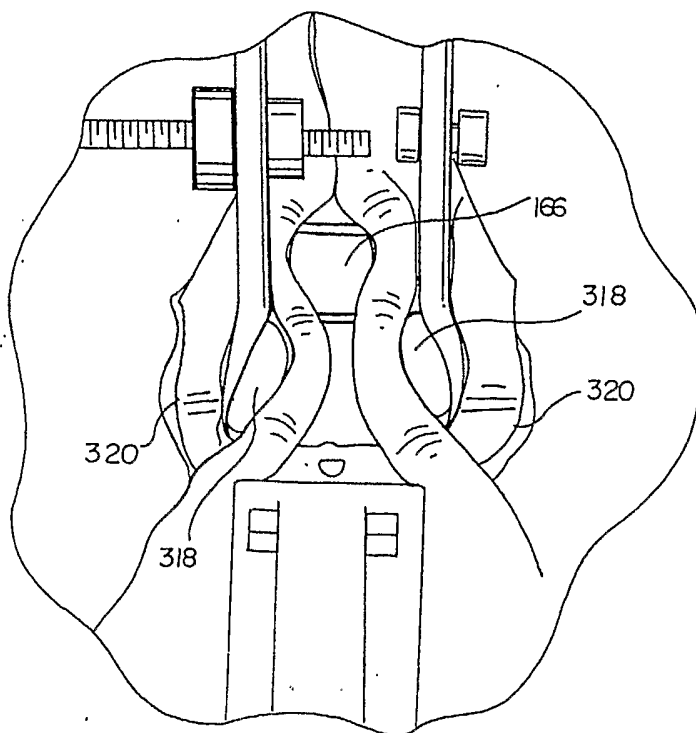

Fig.24



17/51
Fig.25

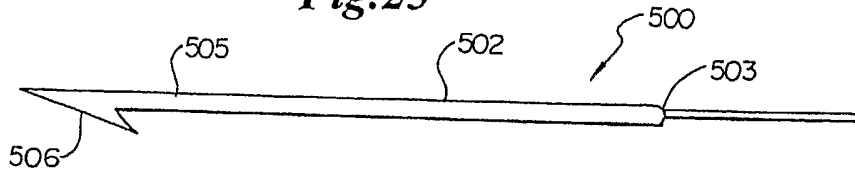

Fig.26

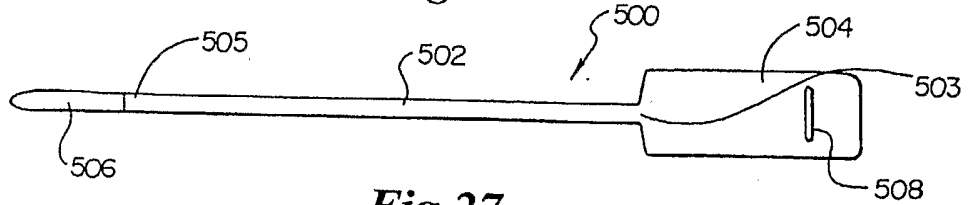

Fig.27

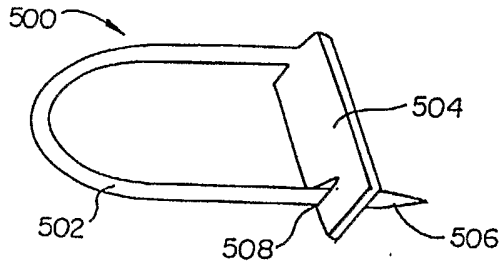

Fig.28

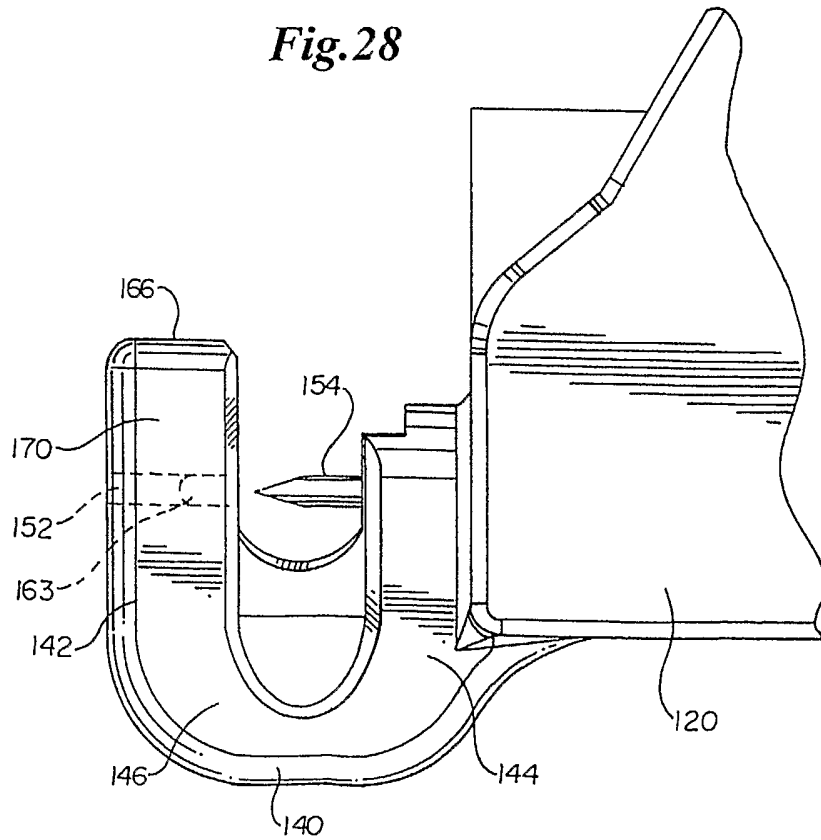

Fig. 29

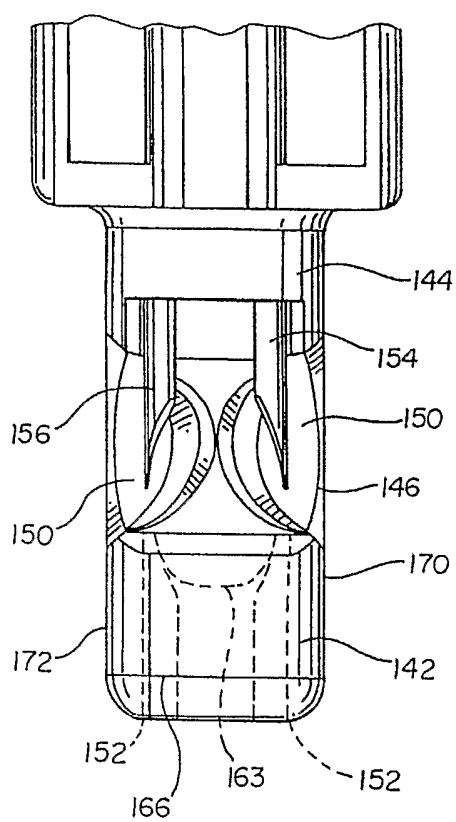

Fig.30

PRIOR ART

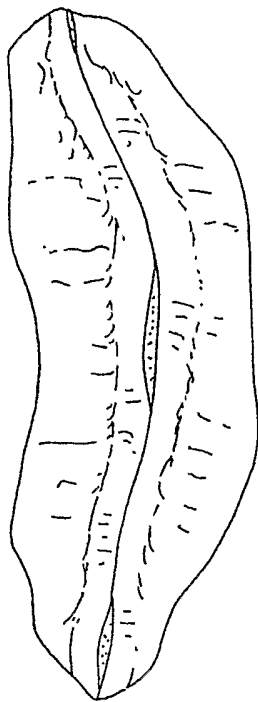

Fig.31

PRIOR ART

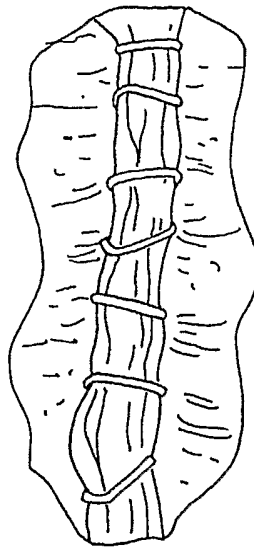

Fig.32

PRIOR ART

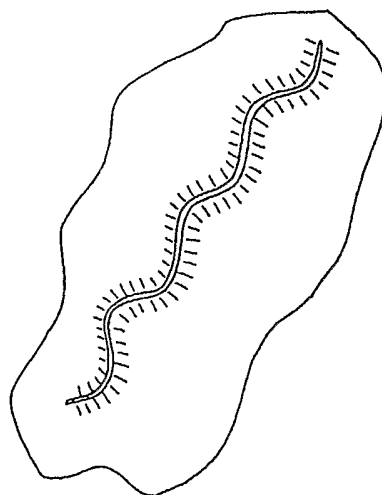
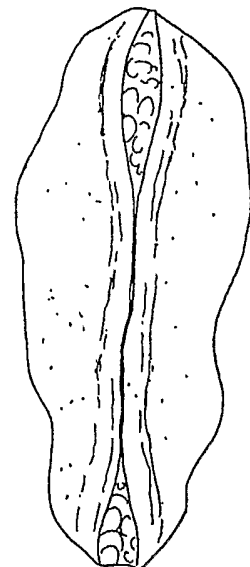

Fig.33



20/51
Fig.34

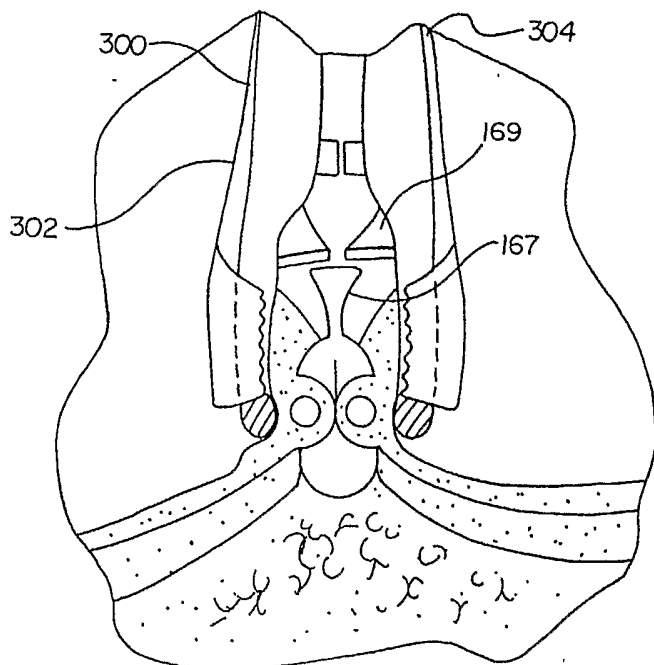

Fig.36

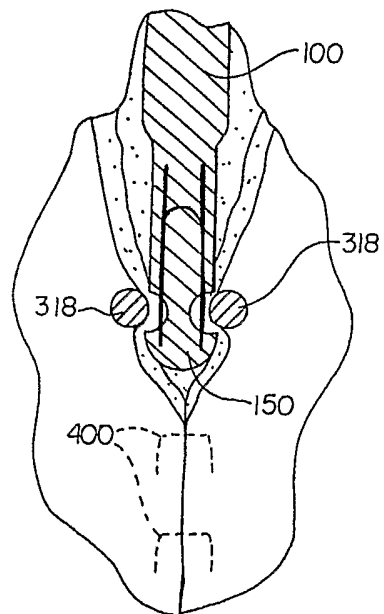

Fig.35

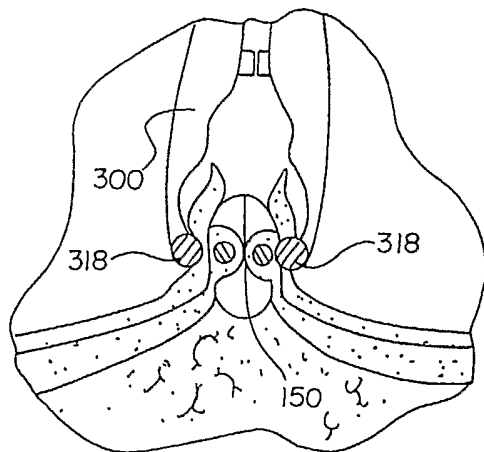

Fig.37

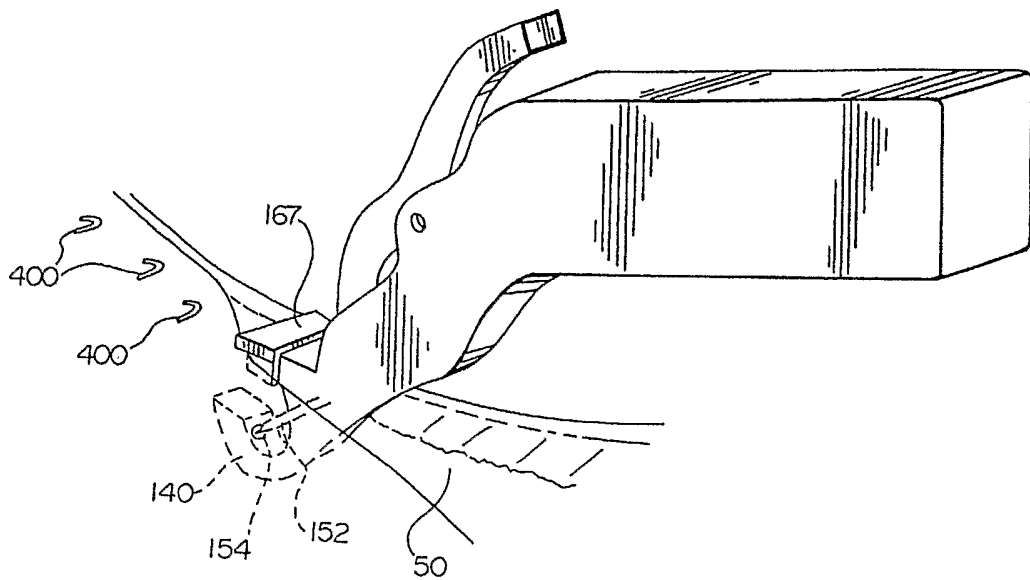

Fig.38

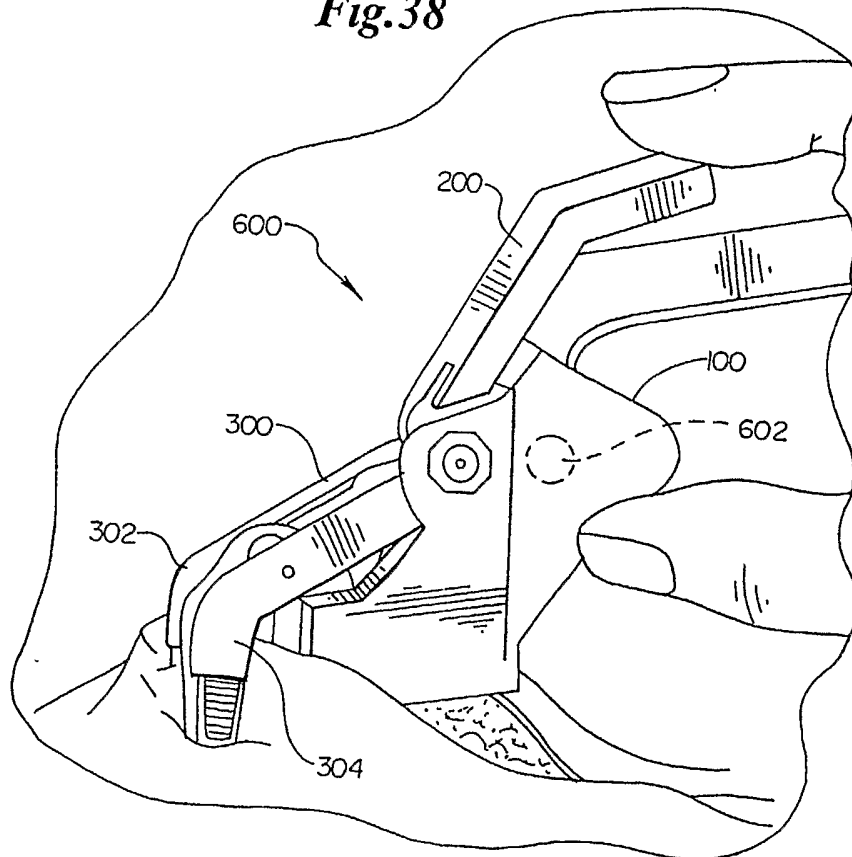

Fig.39

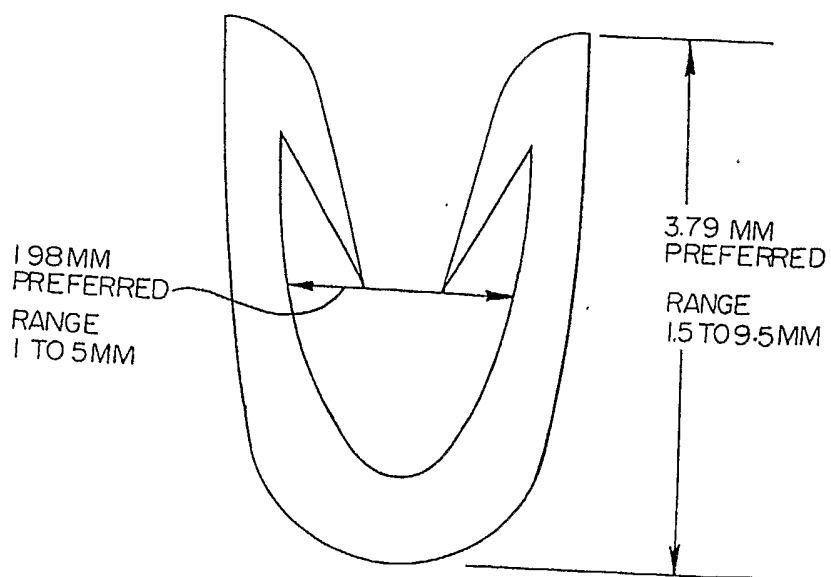

Fig. 41

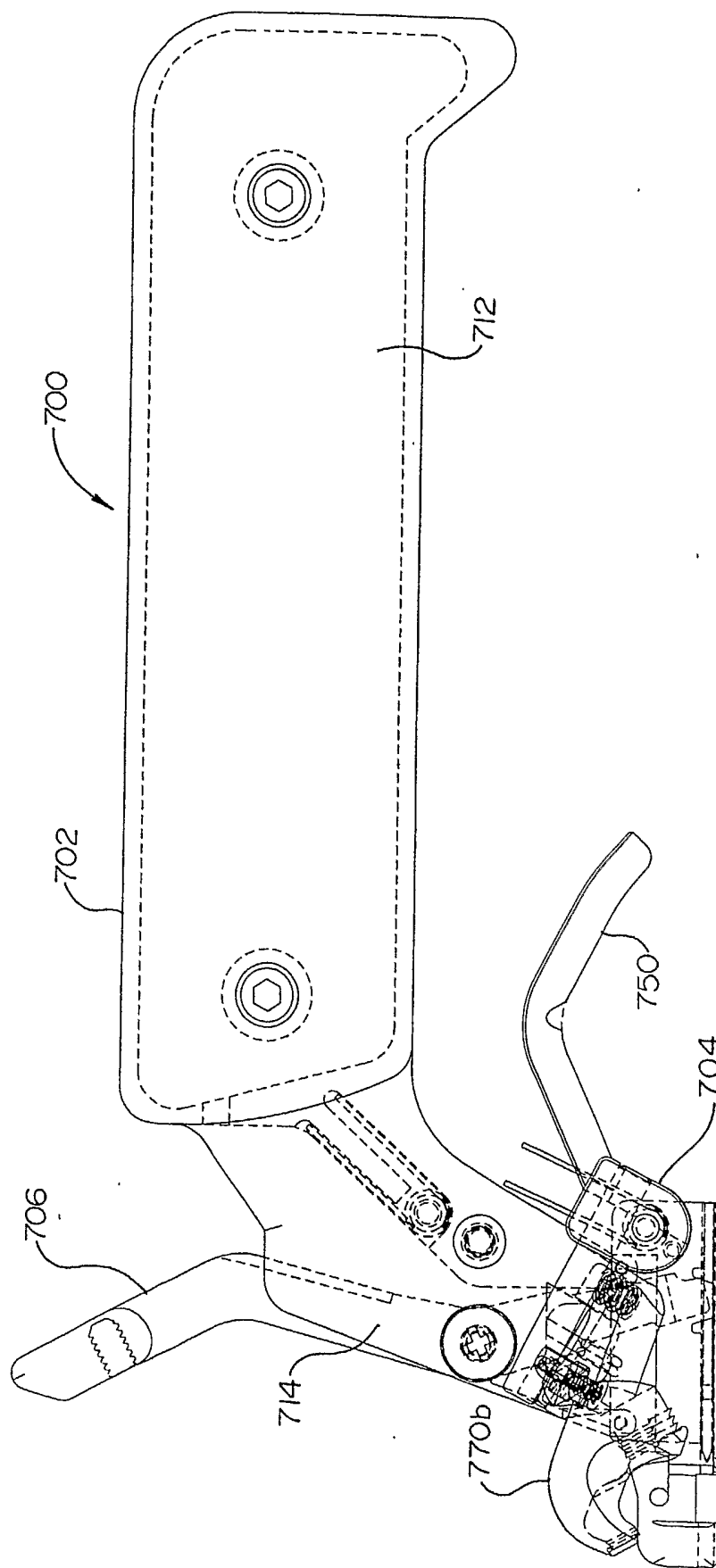
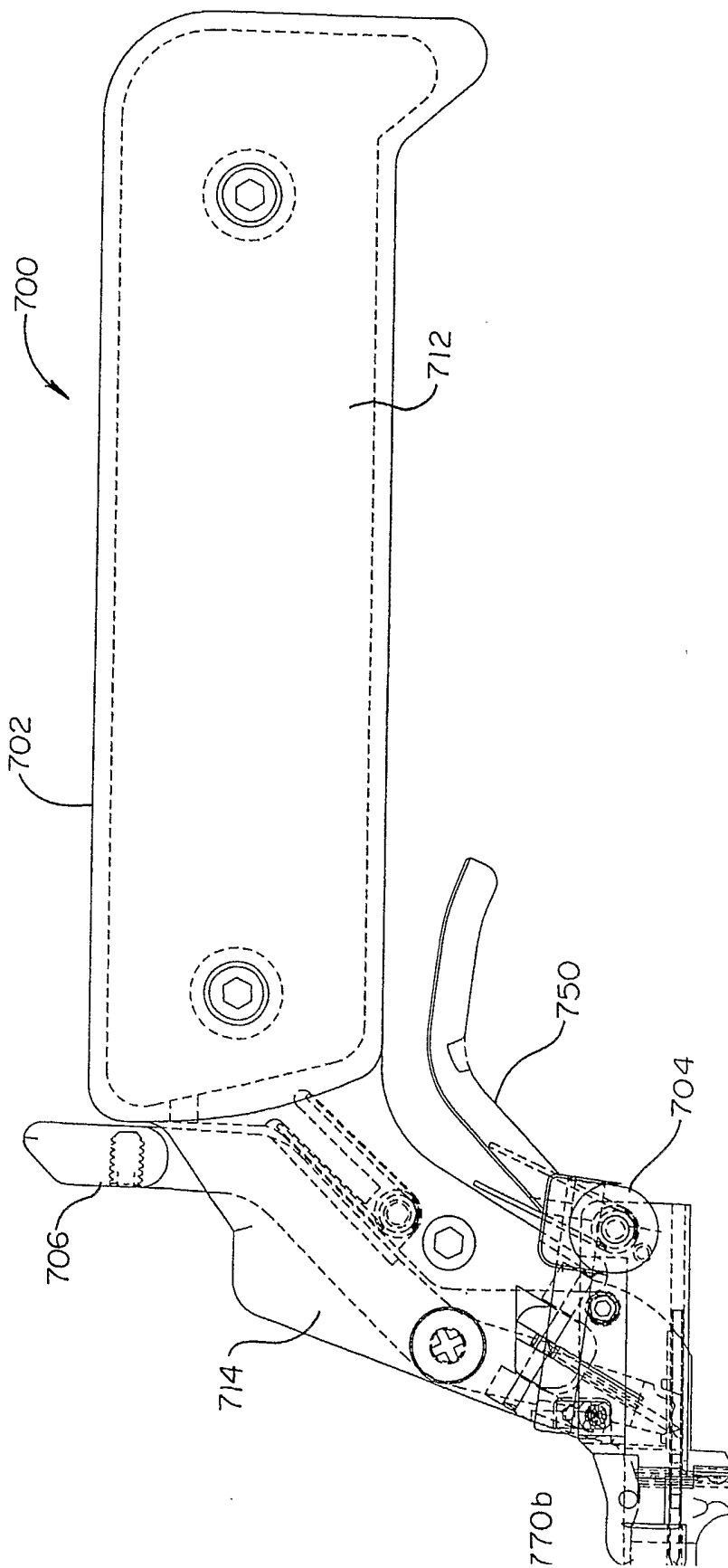

Fig.42



26/51

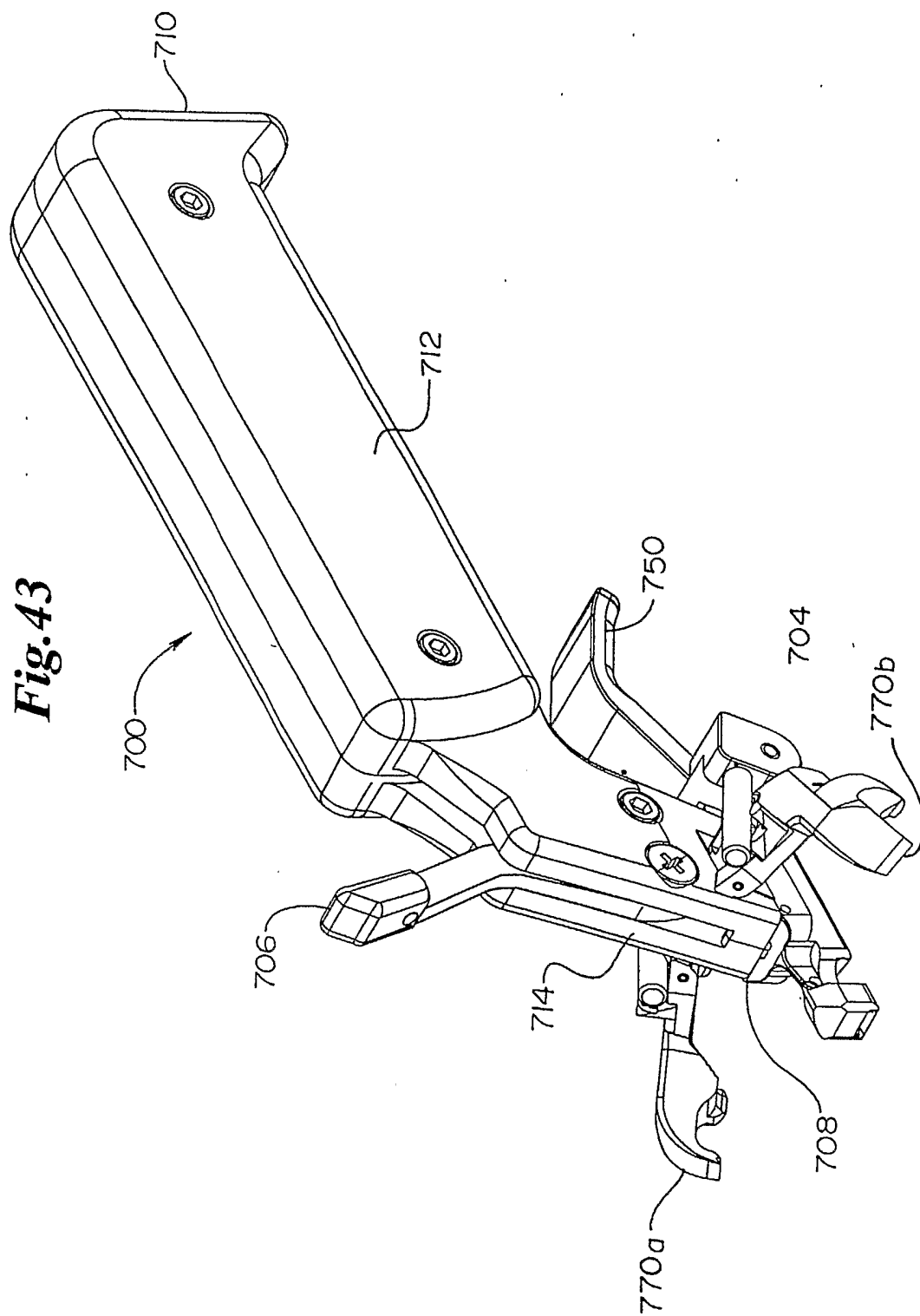

Fig. 43

Fig. 44

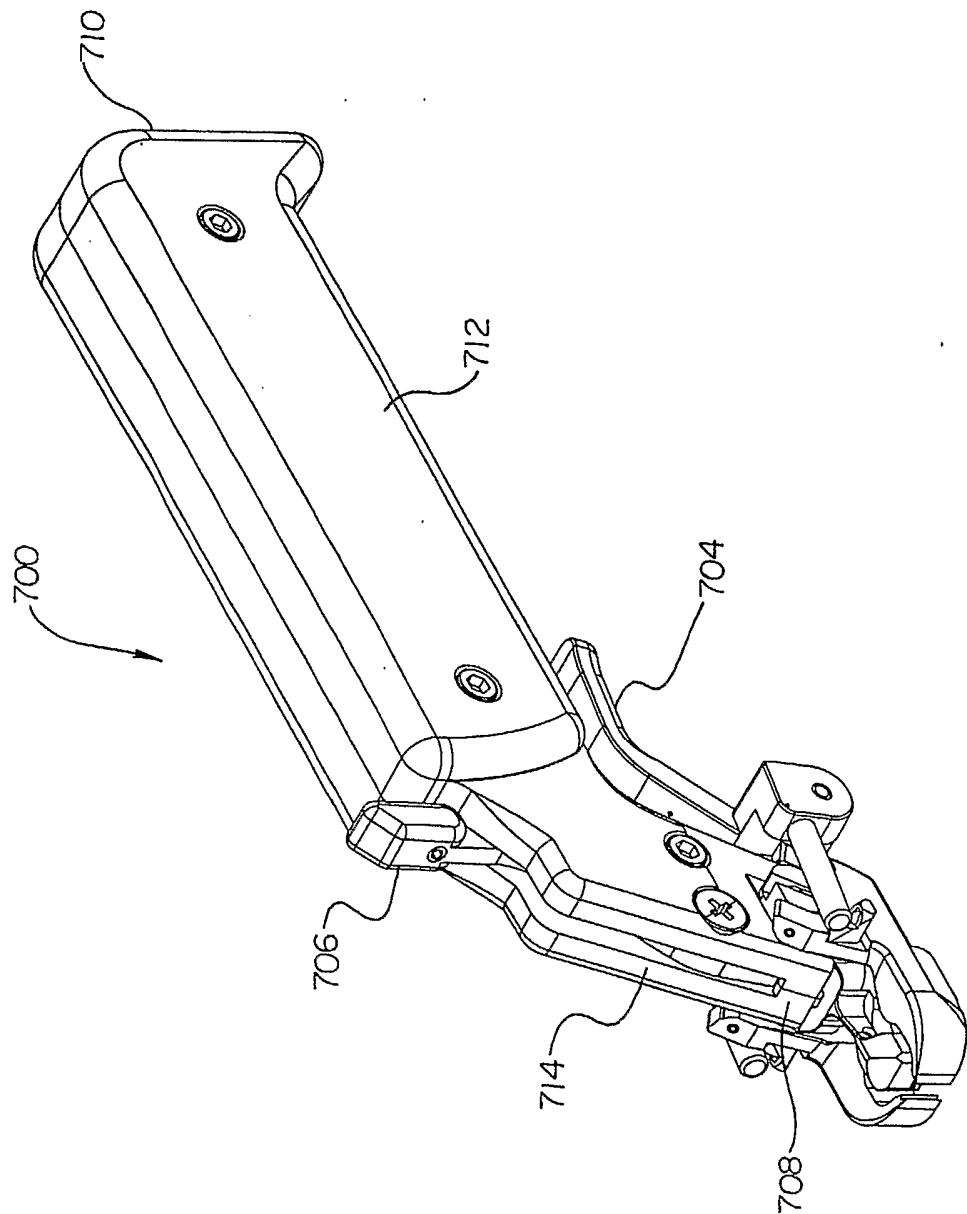

Fig. 45

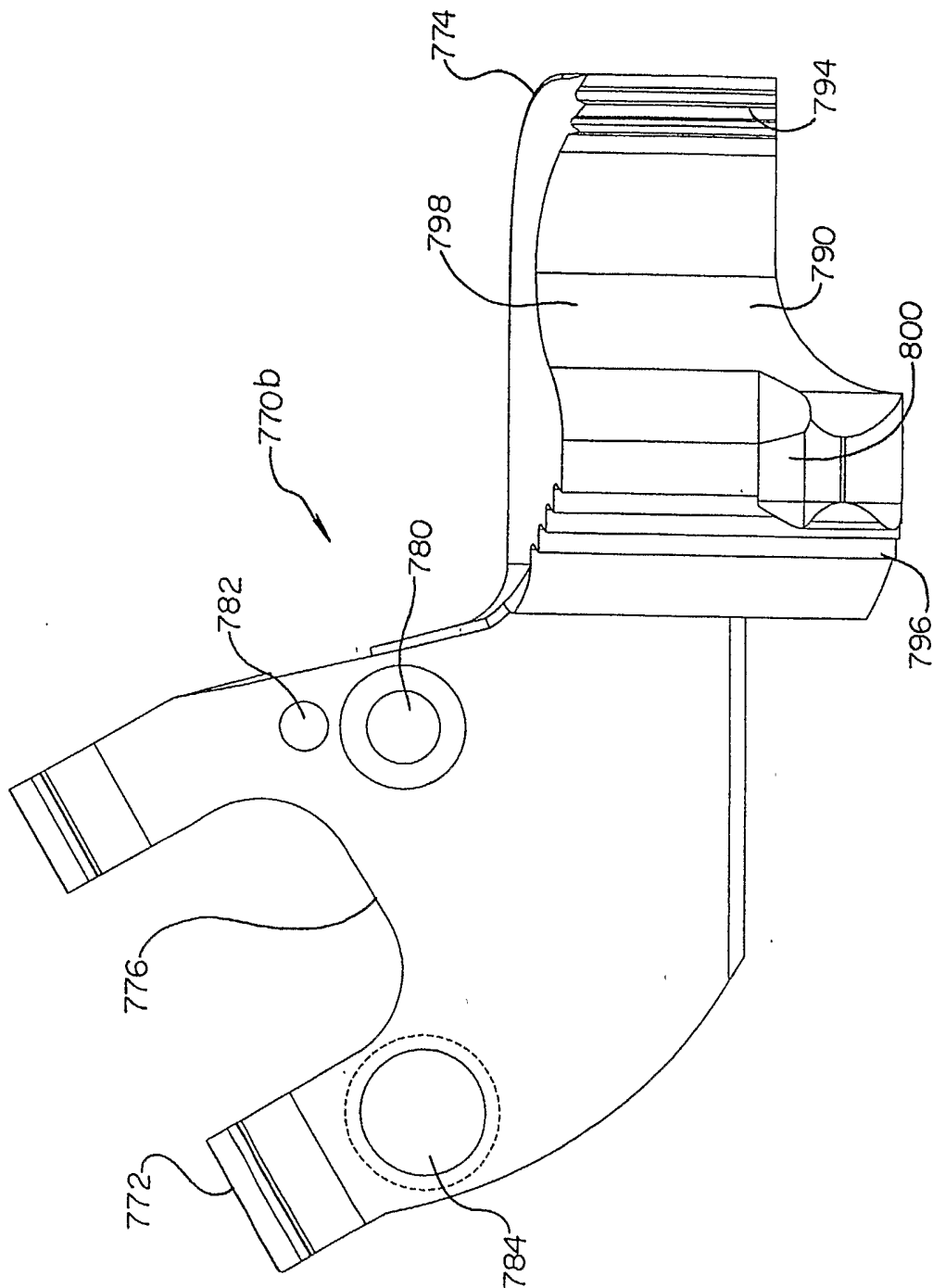

Fig. 46

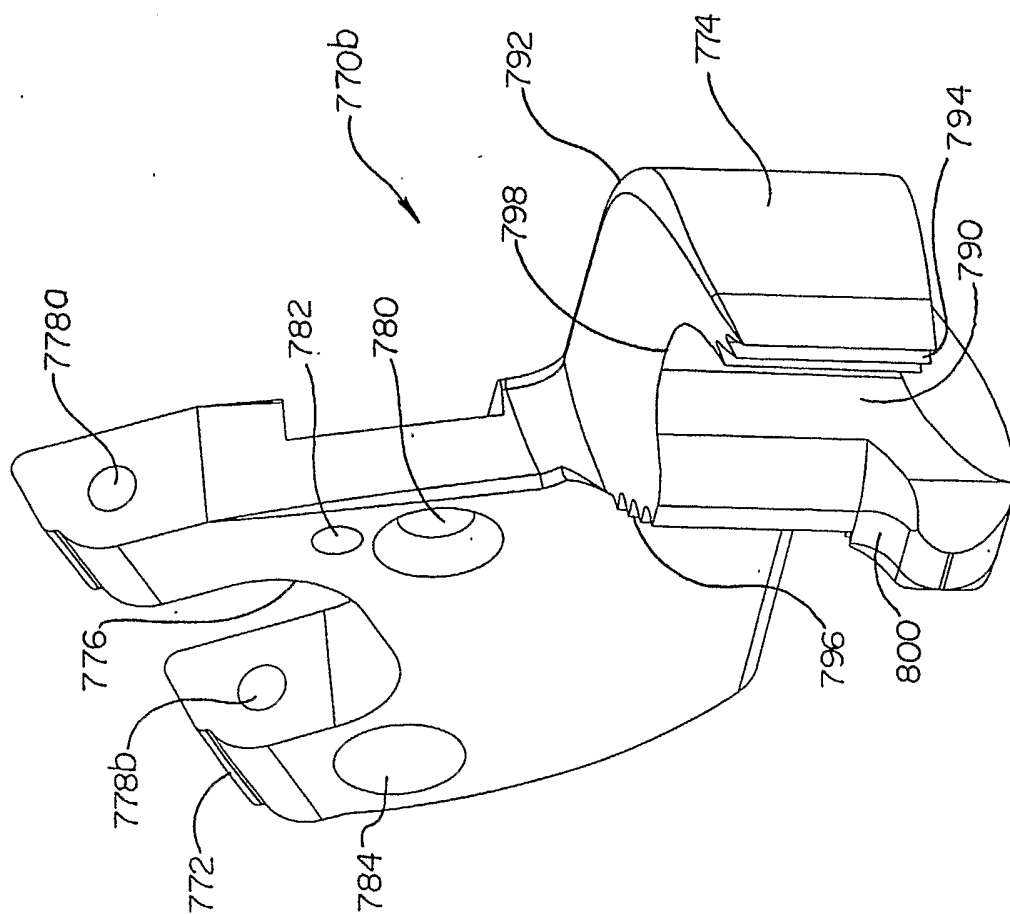

Fig. 47

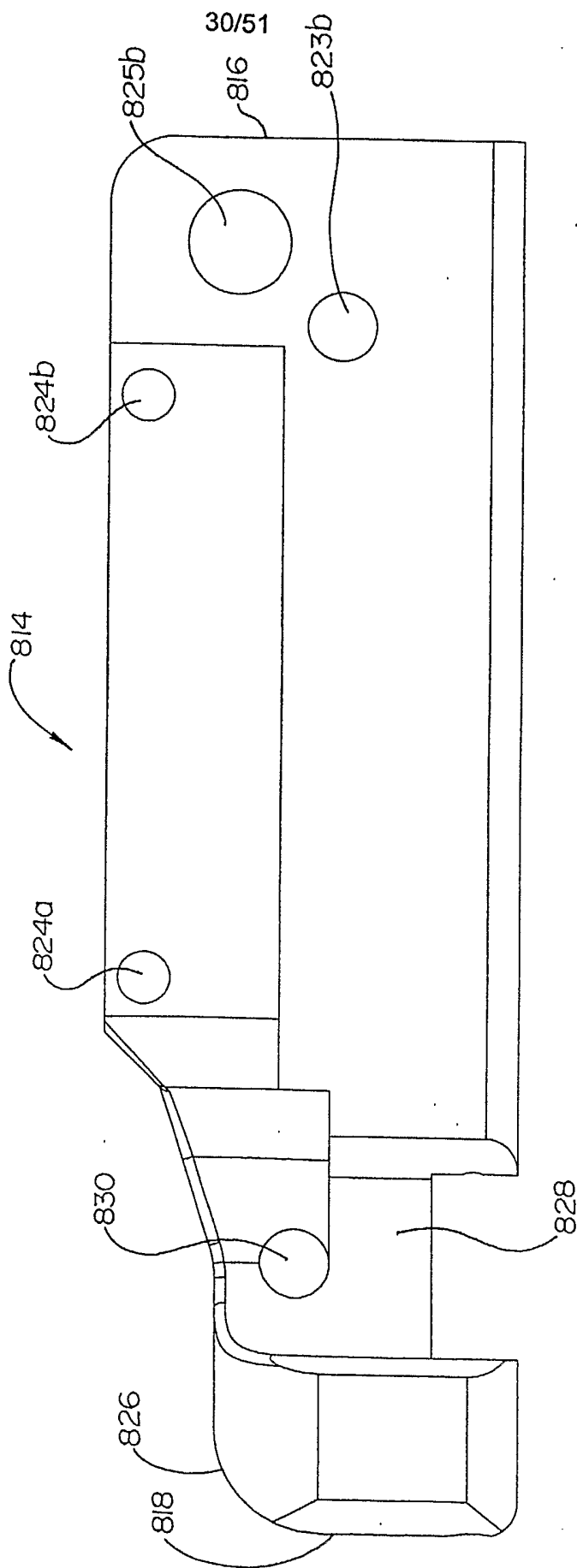

Fig. 49

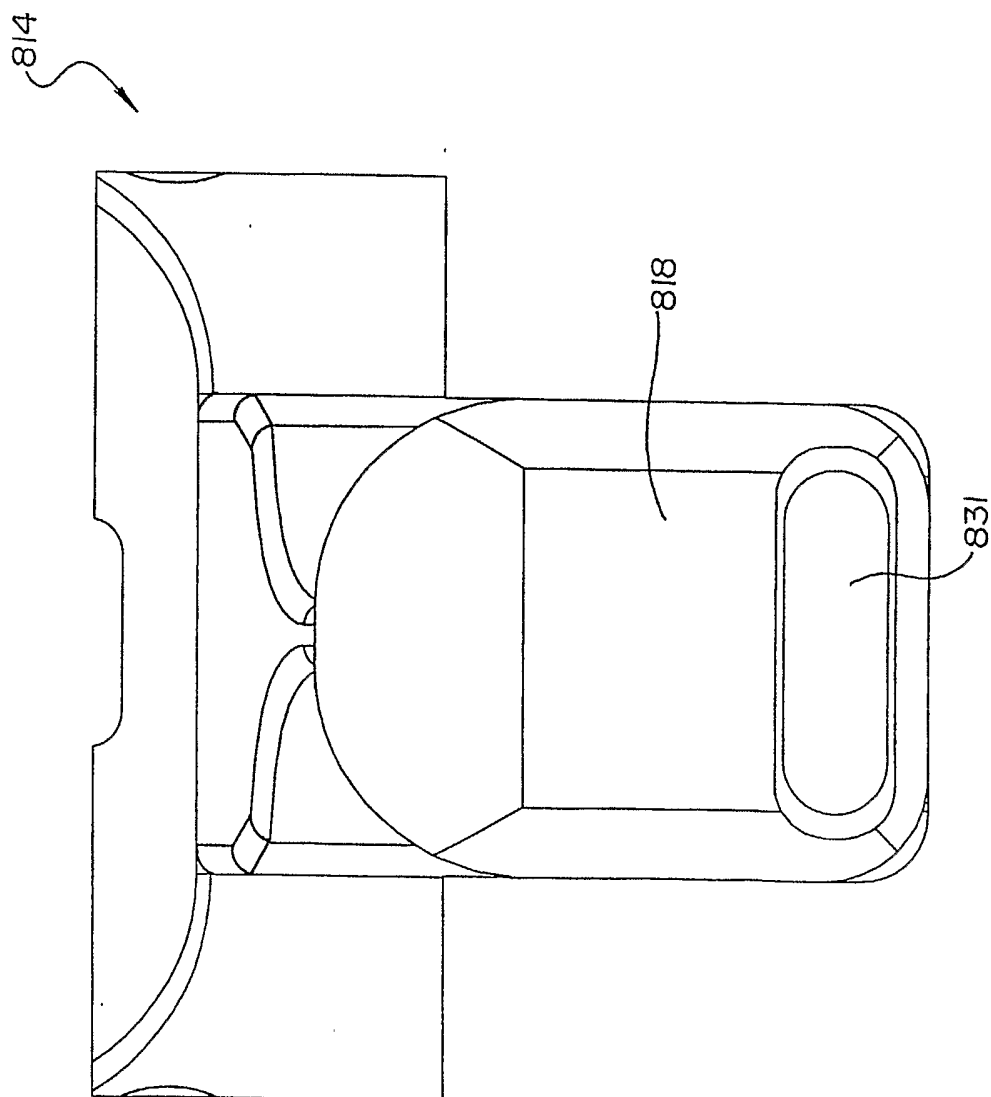

Fig. 50

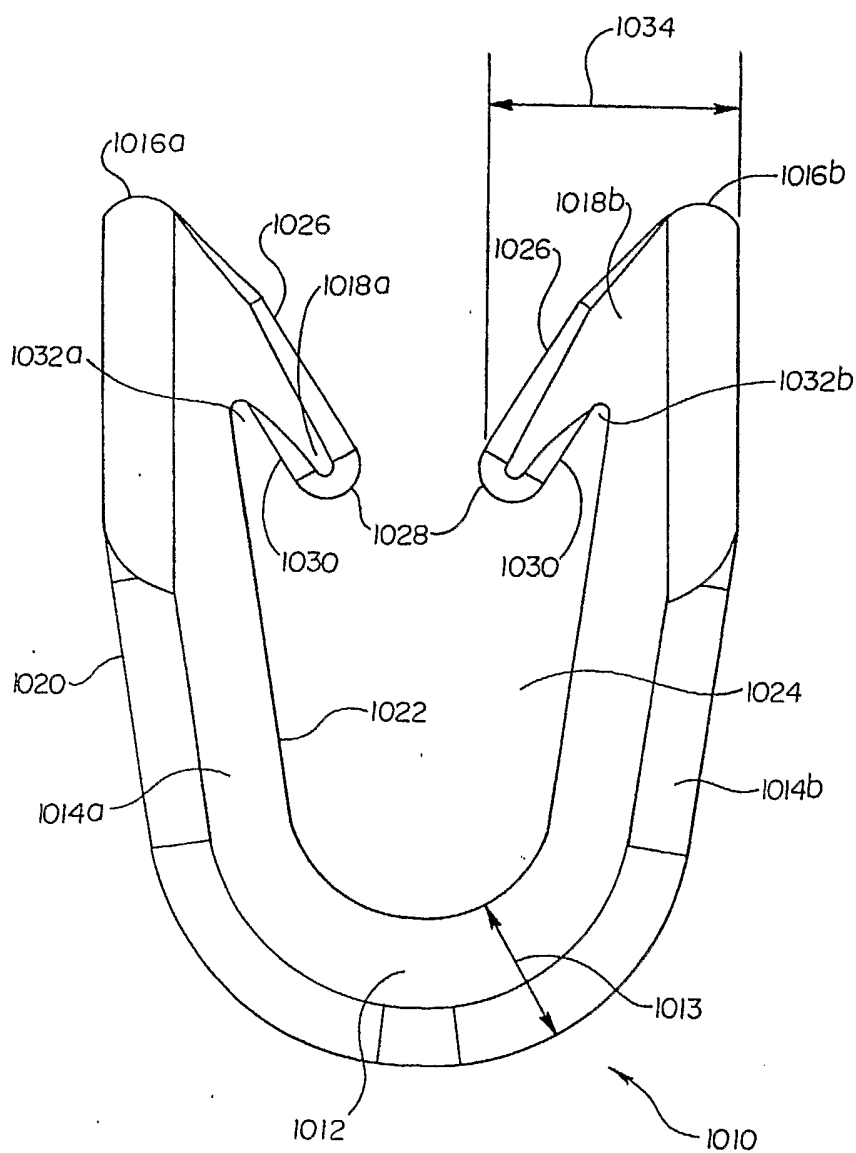

Fig. 51

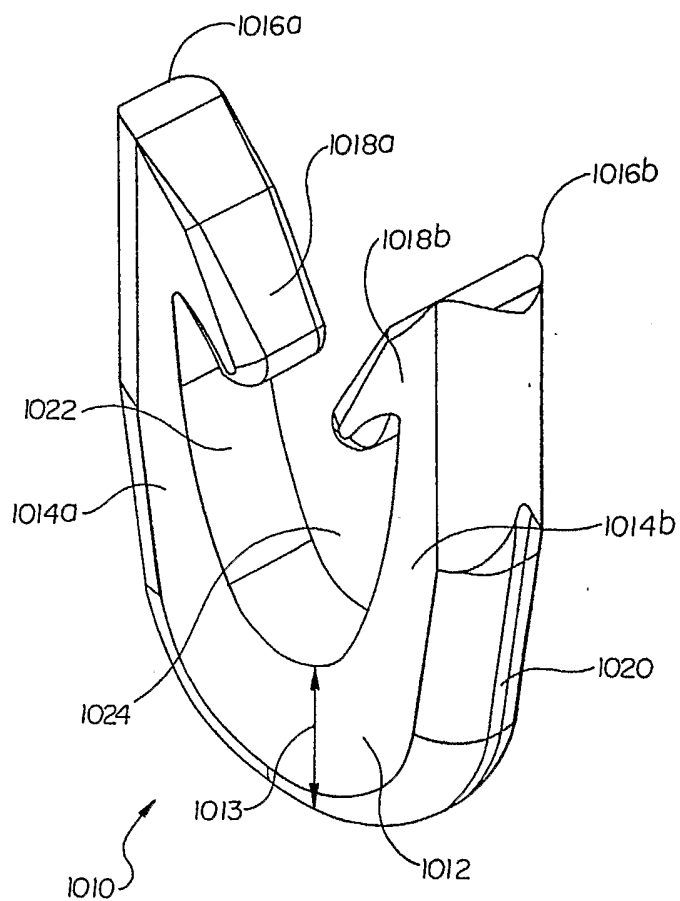

Fig. 52

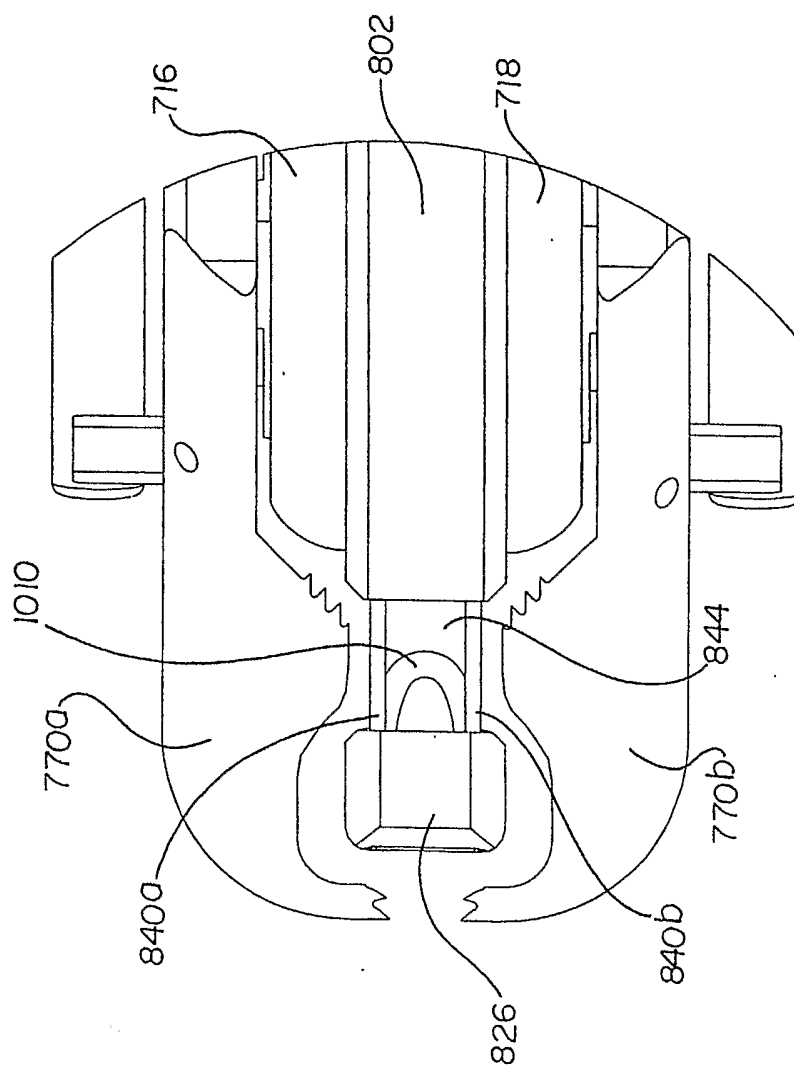
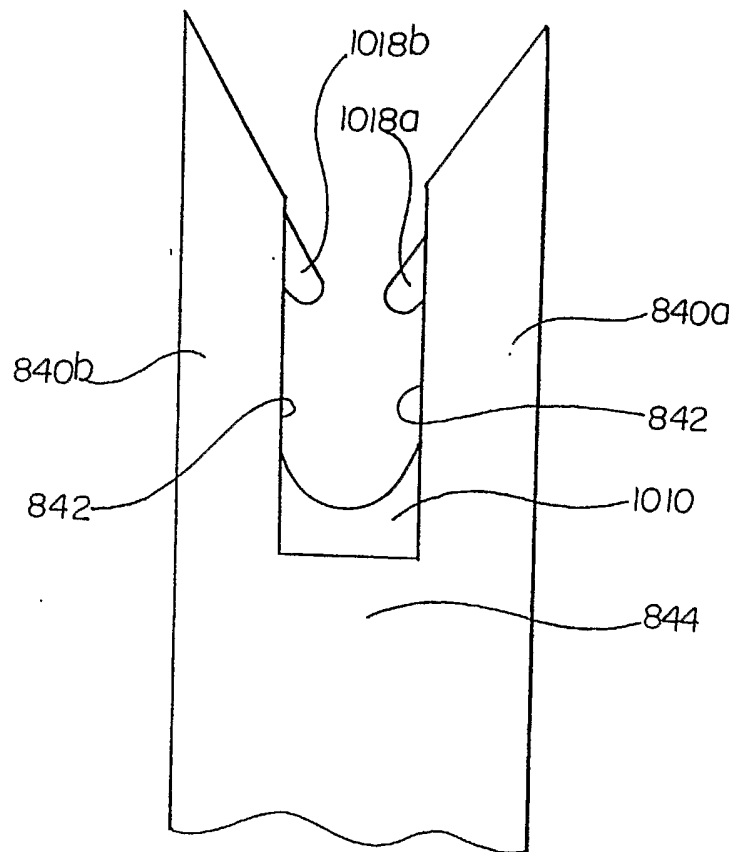
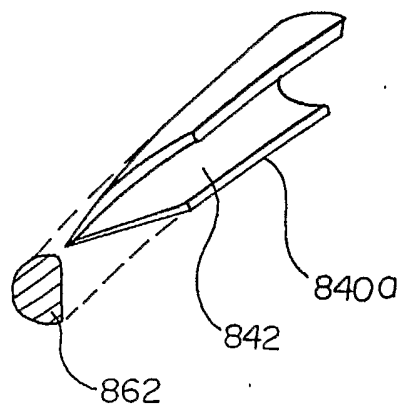

Fig. 53



37/51

Fig. 54



38/51

Fig.55

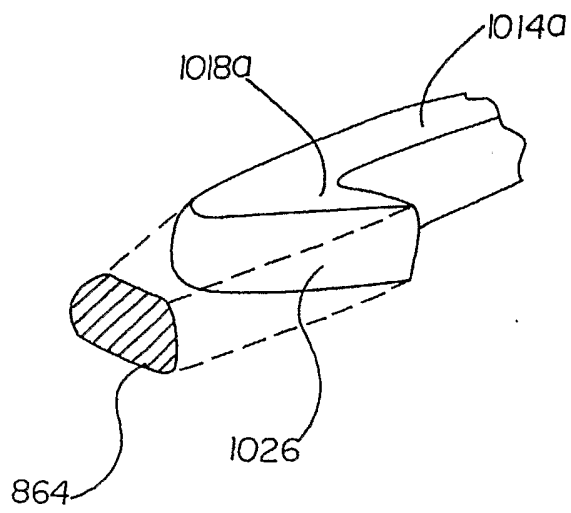

.39/51

Fig.56

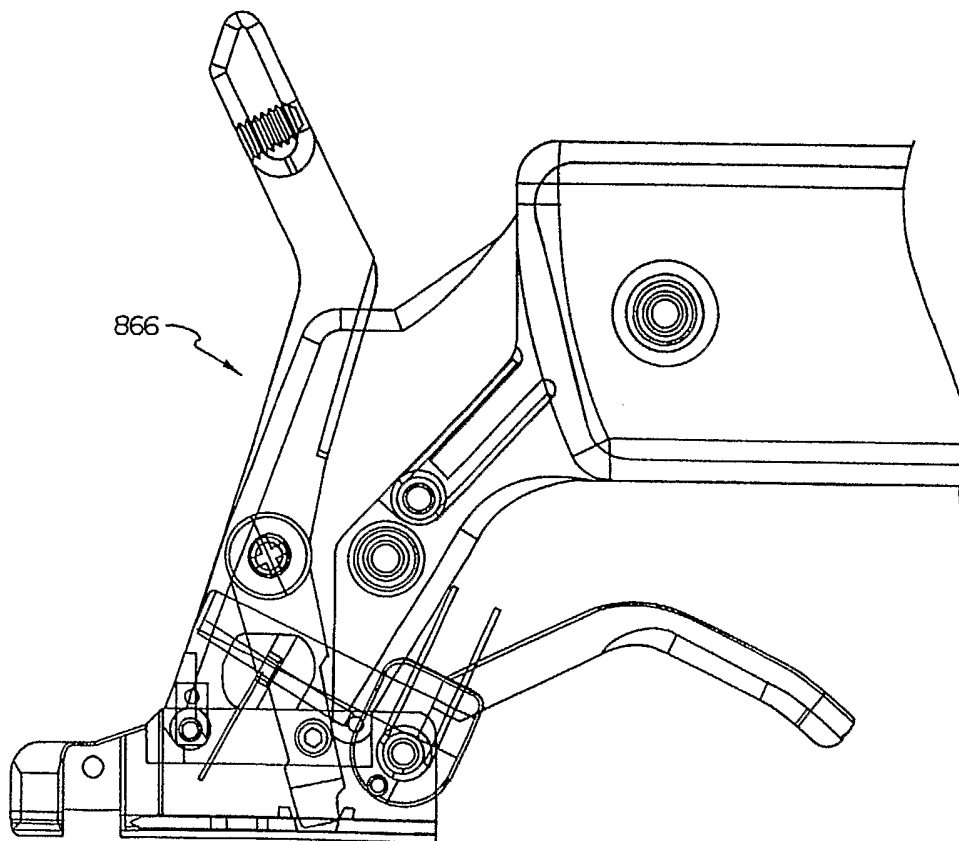

40/51

Fig.57

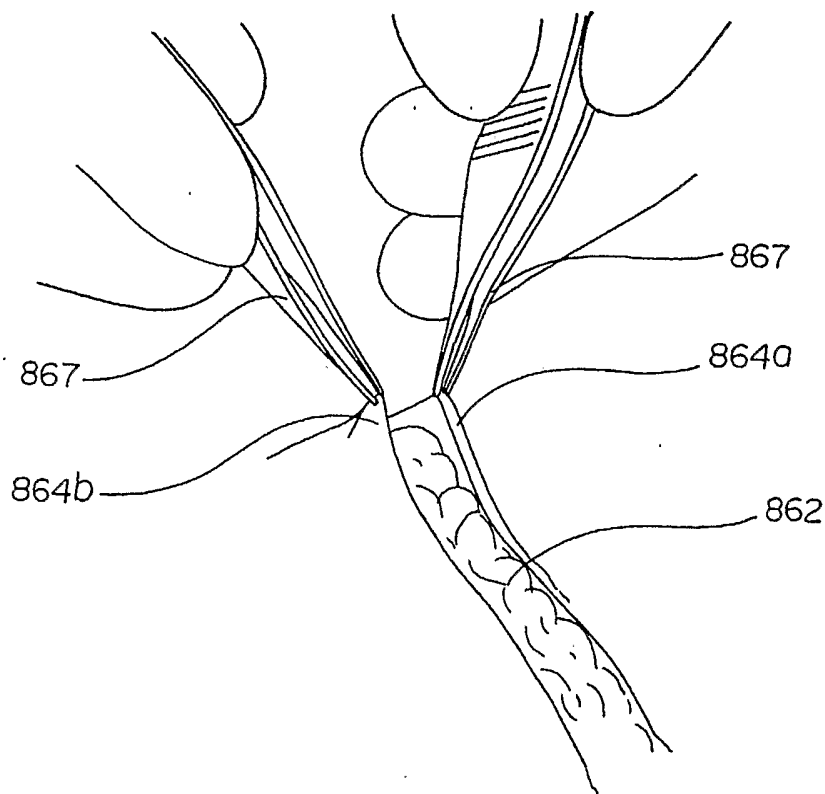

Fig.58

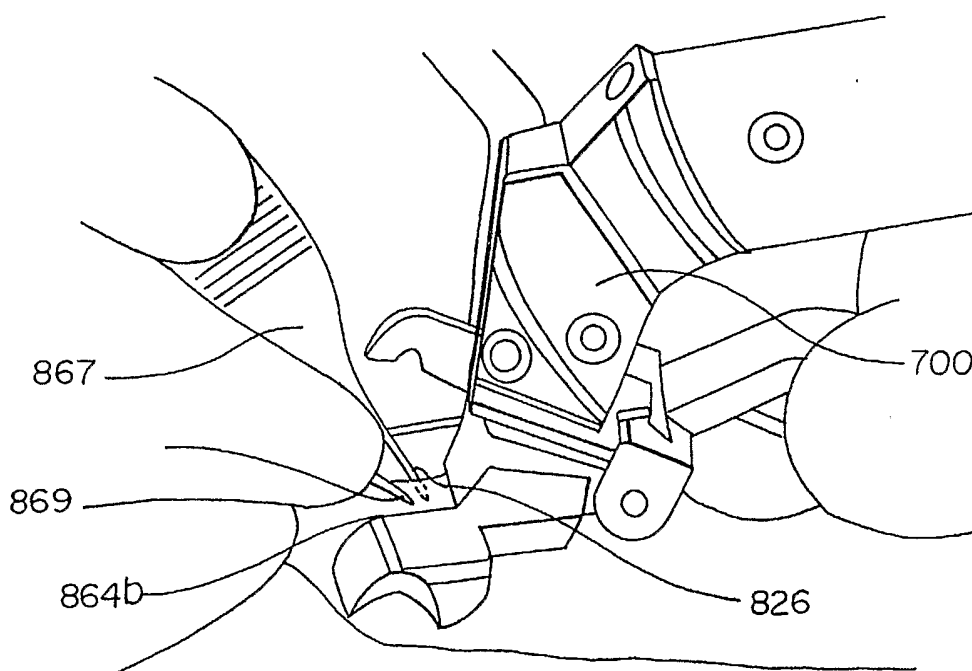

Fig. 59

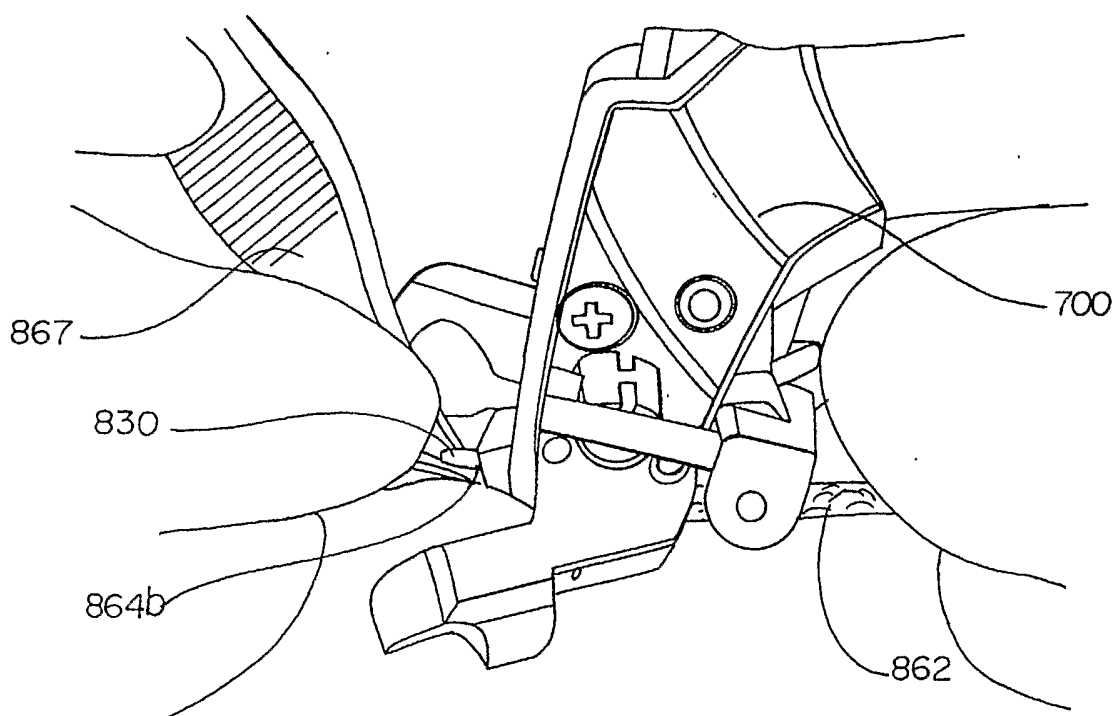

Fig.60

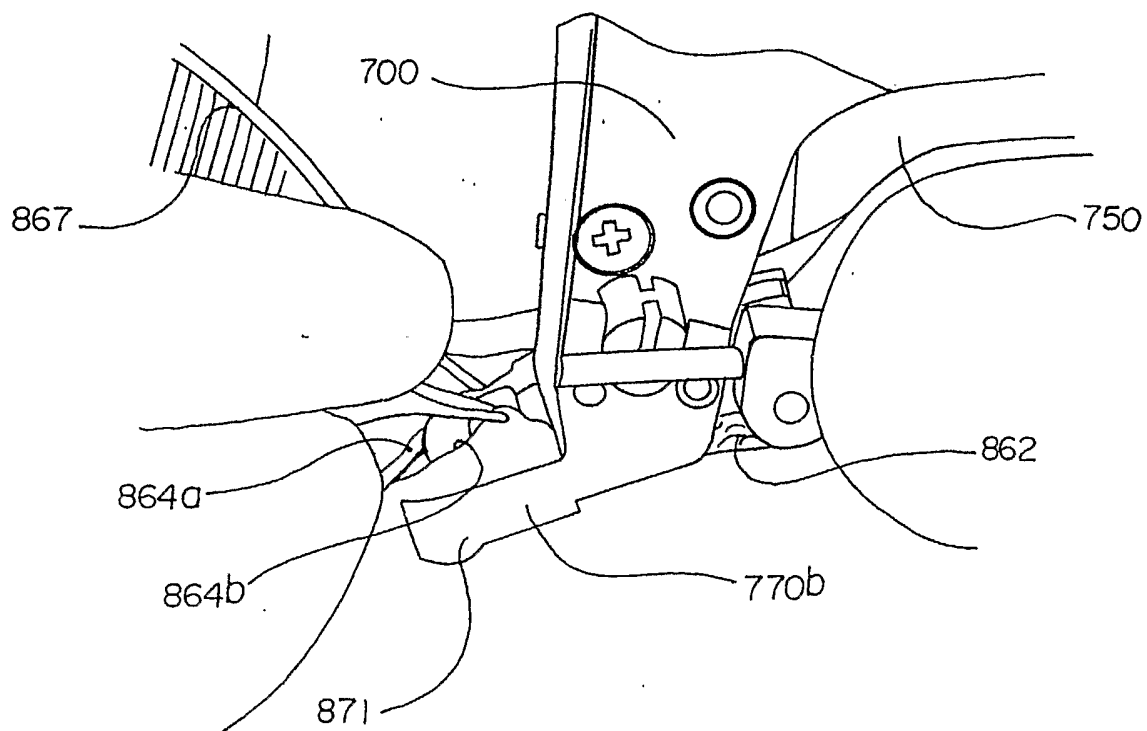

Fig. 61

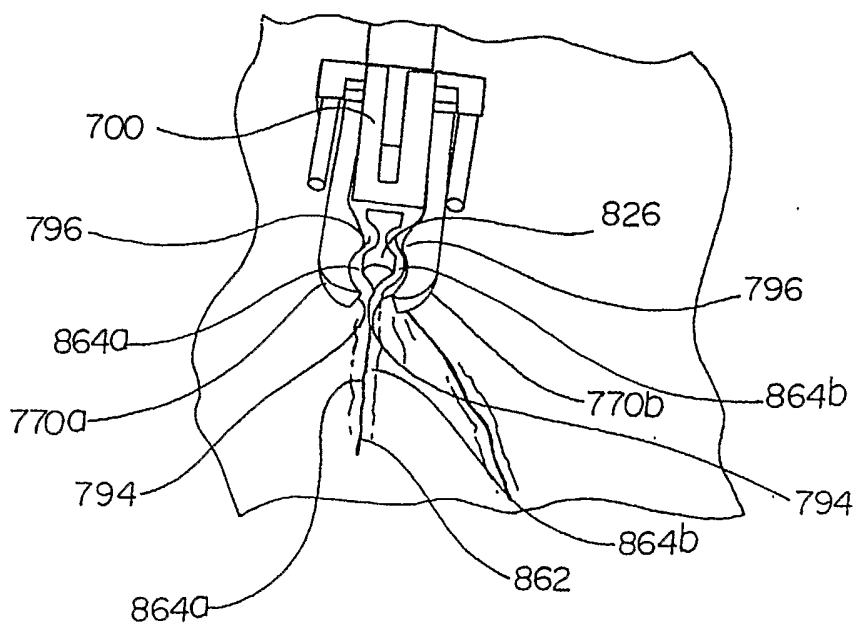

Fig. 62

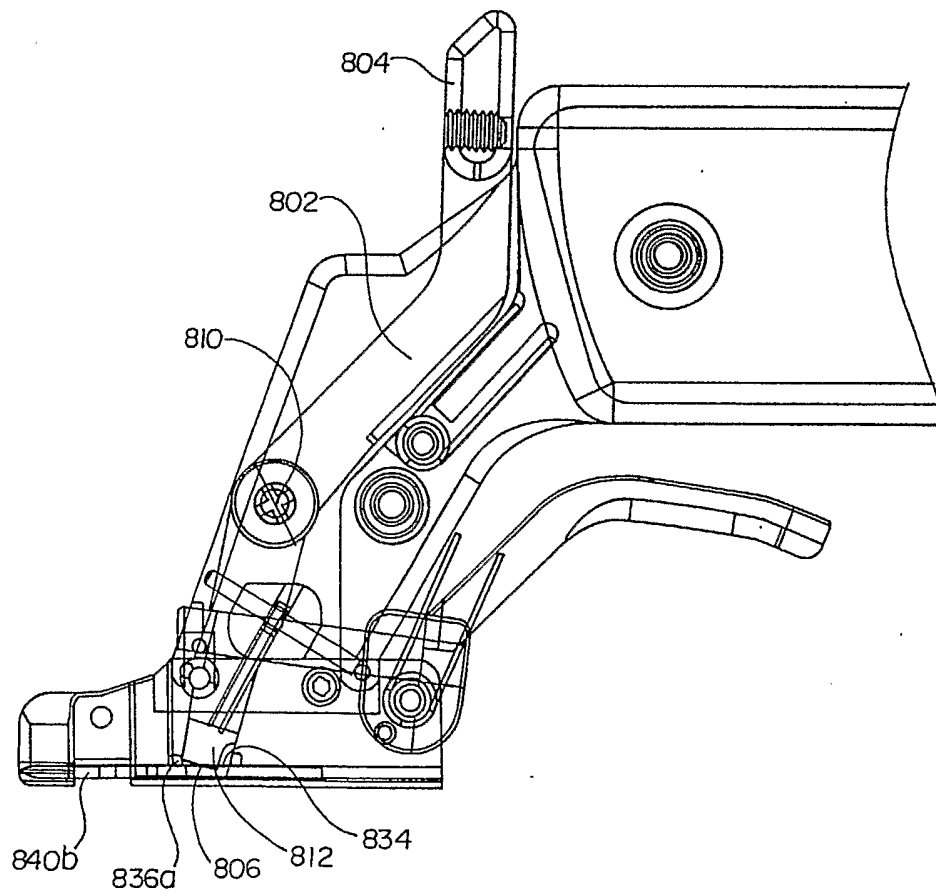
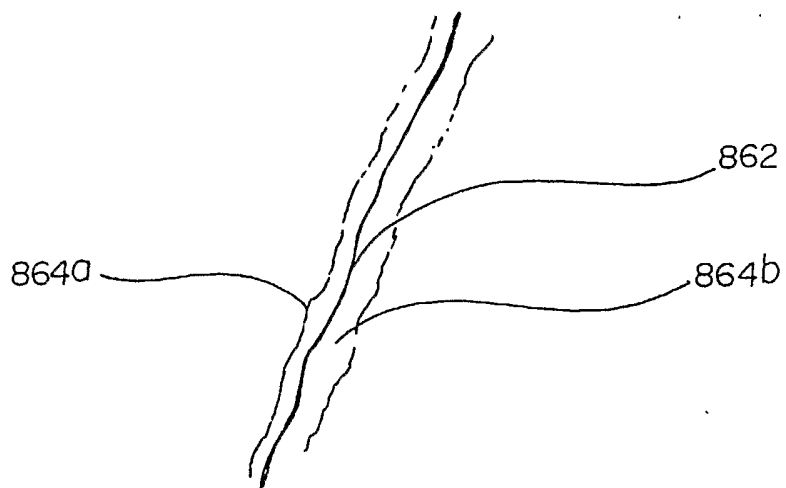

Fig. 63



47/51

Fig. 64

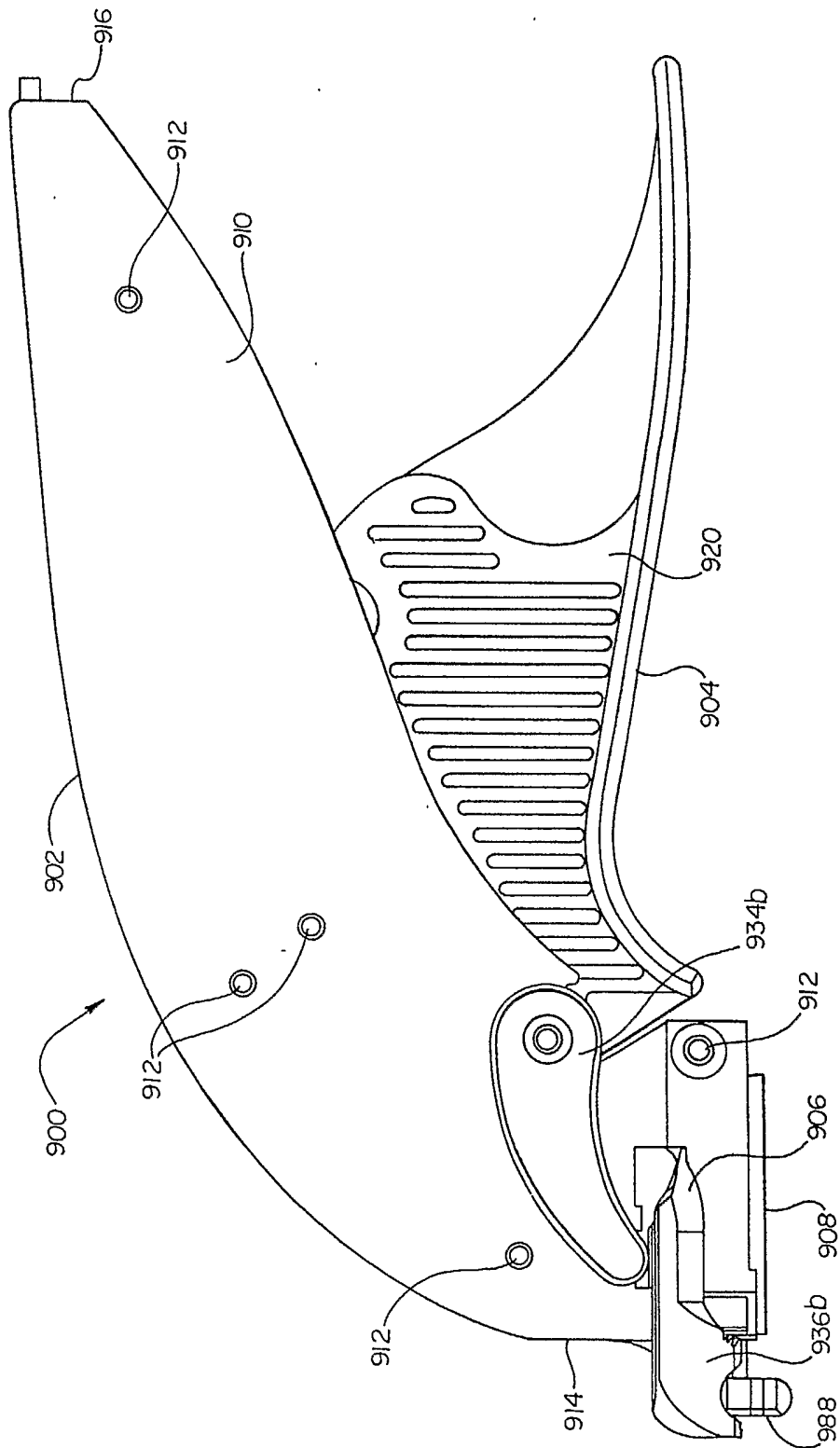

Fig.65

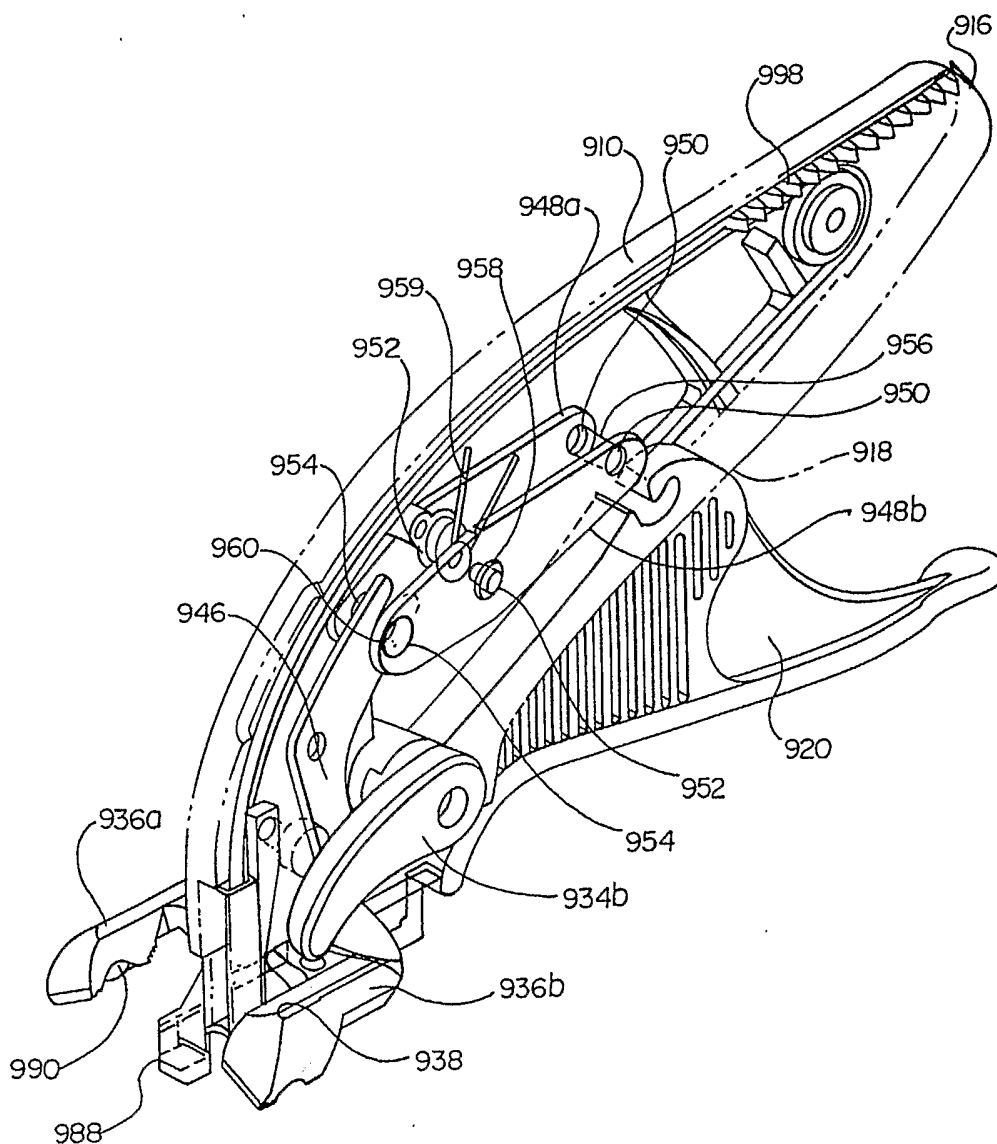
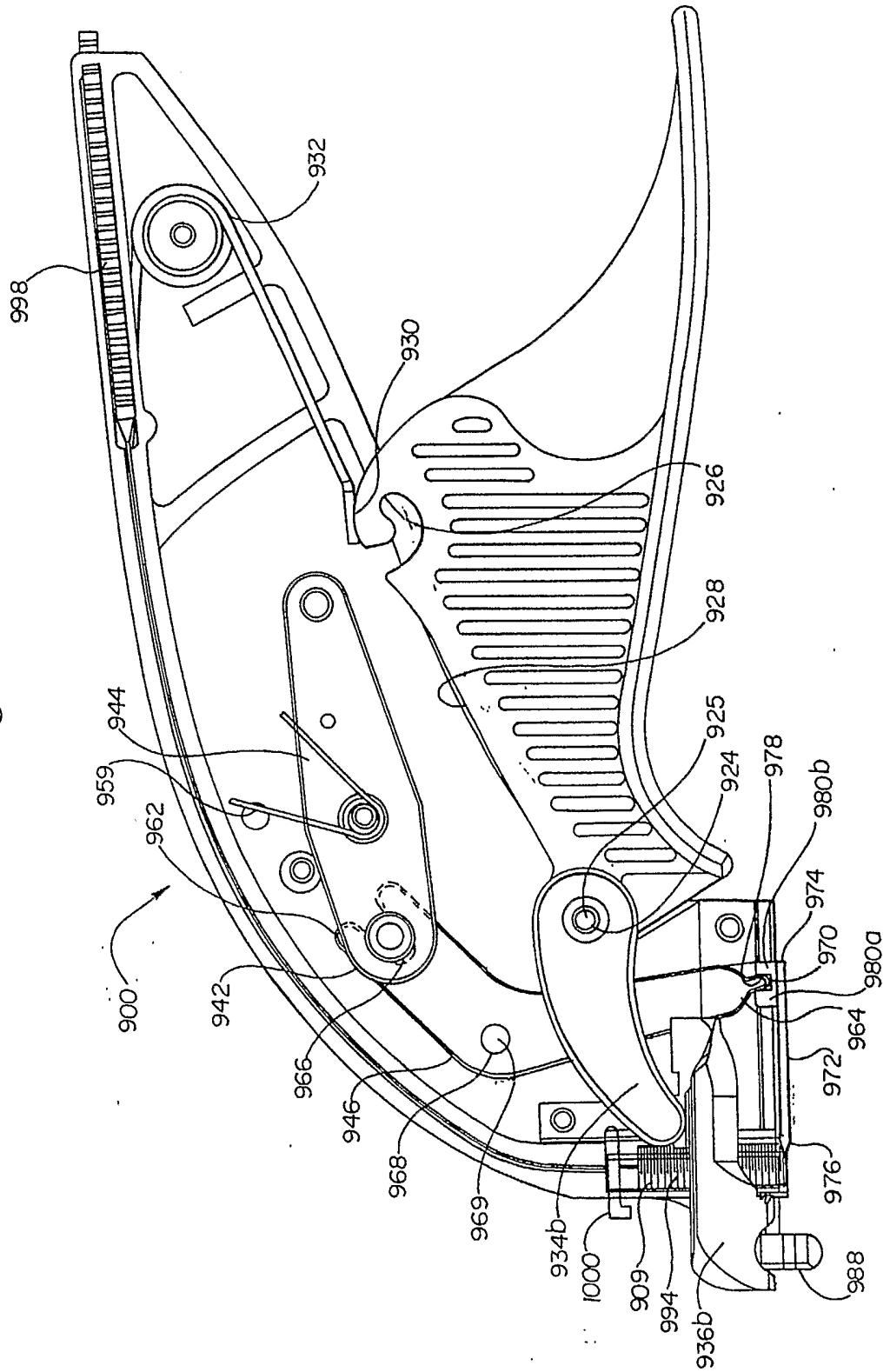
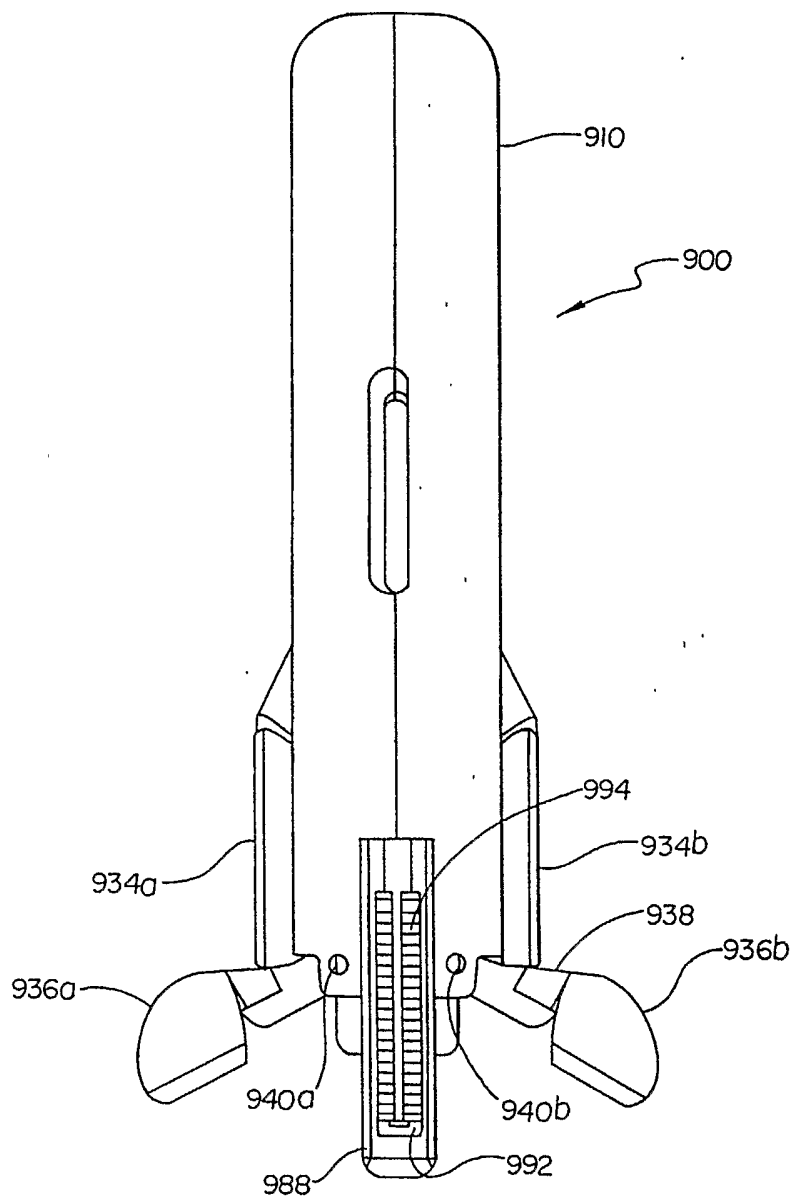

Fig.66



50/51

Fig. 67



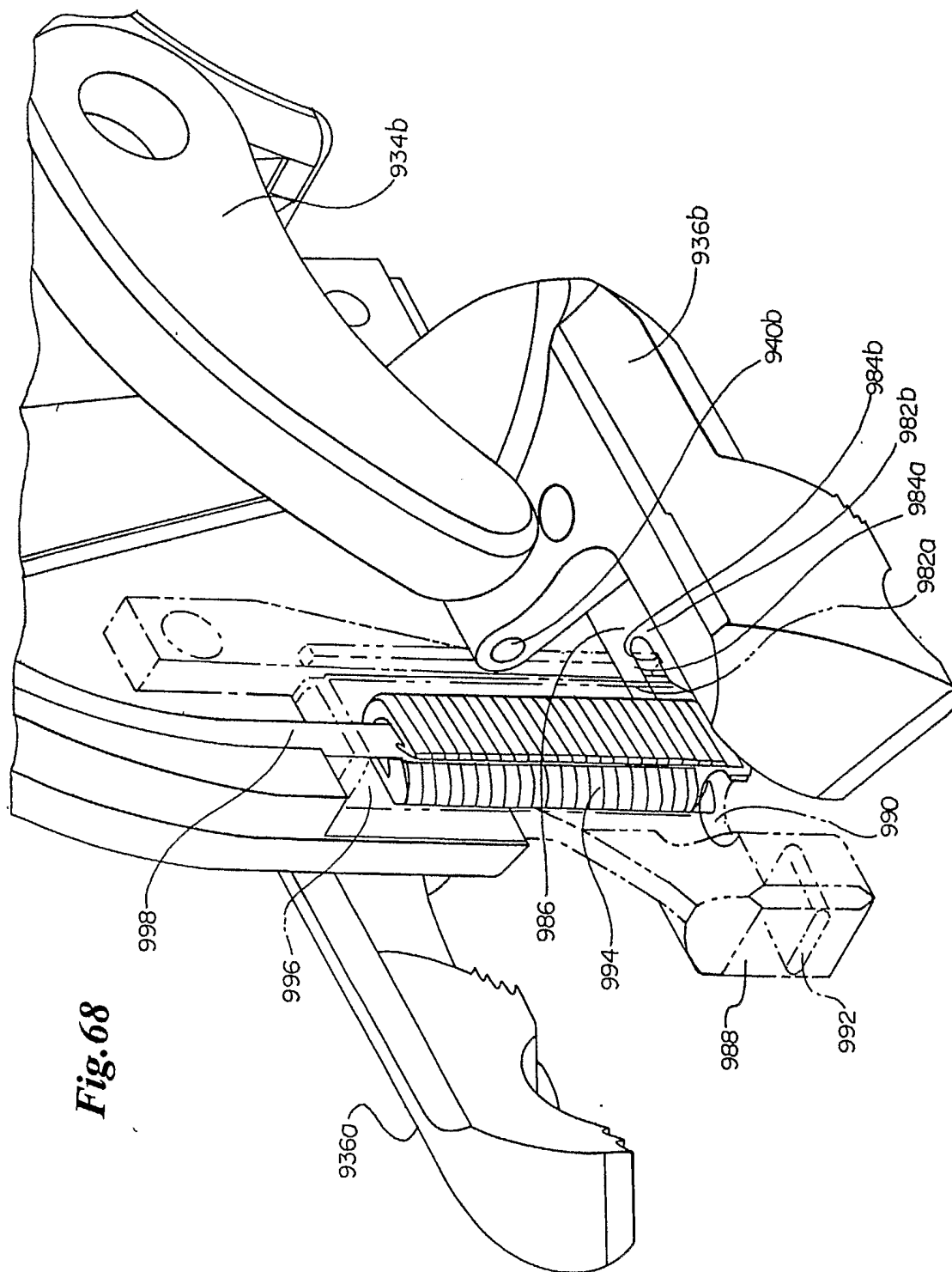

Fig. 68