

Street, & Stebbins

# Bradshaw & Crockett.

## Rotary Measure.

No. 108,871.

Patented Nov. 1, 1870.

Fig. 1.

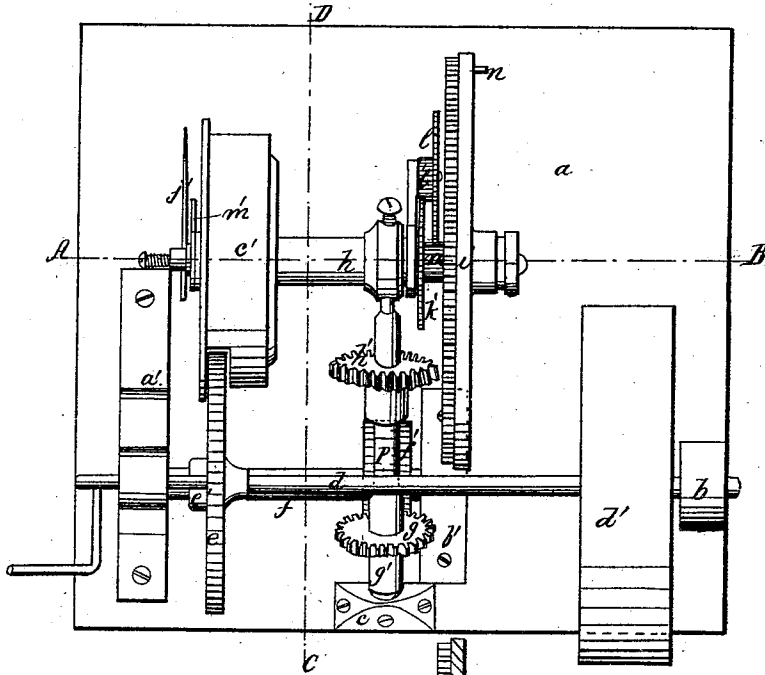
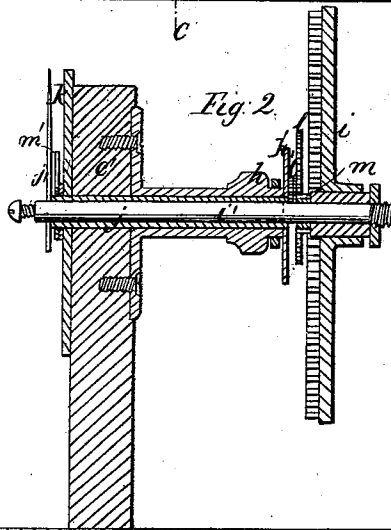

Fig. 2.



Witnesses;  
John E. Crane  
Wm. H. Brown

Inventors;  
John A. Bradshaw  
Selden S. Crockett

# Bradshaw & Crockett.

## Rotary Measure.

N<sup>o</sup> 108,871.

Patented Nov. 1, 1870.

Fig. 3.

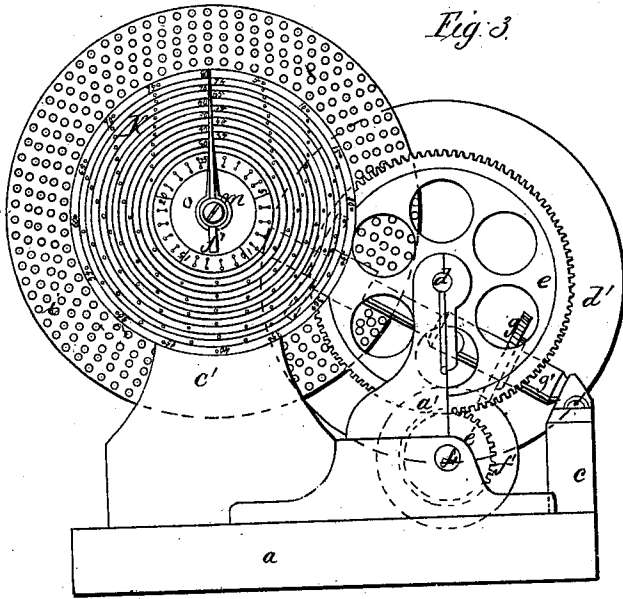
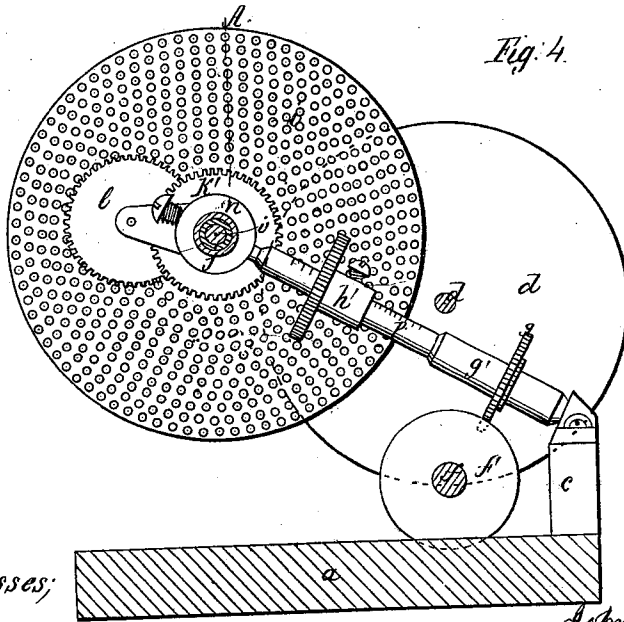

Fig. 4.



Witnesses:  
R. T. Rawson.  
Geo. C. Perry.

Inventors:  
John A. Bradshaw  
Seldon S. Crockett

# UNITED STATES PATENT OFFICE.

JOHN A. BRADSHAW AND SELDON L. CROCKETT, OF LOWELL, MASSACHUSETTS, ASSIGNORS TO SELDON L. CROCKETT.

## IMPROVEMENT IN MEASURING APPARATUS FOR LOOMS, &c.

Specification forming part of Letters Patent No. 108,871, dated November 1, 1870; antedated October 21, 1870.

*To all whom it may concern:*

Be it known that we, JOHN A. BRADSHAW and SELDON L. CROCKETT, both of Lowell, in the county of Middlesex and State of Massachusetts, have invented certain new and useful Improvements in Length-Indicators for Looms, Spinning-Frames, and Dressers, of which the following is a full, clear, and exact description, reference being had to the accompanying drawings, making part of this specification, in which—

Figure 1 represents a plan of our improved machine. Fig. 2 represents a section through line A B of Fig. 1. Fig. 3 represents an end elevation of Fig. 1, showing the double dial and other parts. Fig. 4 represents a section through line C D of Fig. 1.

The nature of our invention consists in providing a measuring-indicator that can be adapted to looms, spinning-frames, or dressers, and indicate at sight the number of yards of yarn spun, the number of yards and cuts of cloth in a web as woven, and the number of yards and cuts of warp dressed, without a change of gears, at the same time stopping the machine and allowing the operator to put in the cut-mark as required.

In the construction of our improved measuring apparatus for cotton machinery, *a* represents the base, on the top of which are secured the stands *a'*, *b*, *b'*, *c*, and *c'*. The stands *a'* and *b* are furnished near their tops with bearings for the reception of the shaft *d*, to which is firmly secured, near the stand *b*, the drum *d'*, over which the cloth, yarn, or warp passes, giving the required motion to the clock.

The device *d'*, above referred to, may represent the drying-drum or steam-cylinder of the dresser or roll connected with the loom or other machine to which the apparatus is applied. In constructing and in gearing the indicator the circumference of this drum or roll must be taken into consideration, and the said indicator so geared in relation to the circumference of such drum or roll that each revolution of the latter shall cause the mechanism to indicate a certain measurement of yarn or cloth which has passed over the drum or roll, or between it and another. It is intended that each yard of the moving circumferential sur-

face of the rotating roll shall be indicated on the dial or face of the indicator, regardless of the diameter or size of such roll or the distance round it, and this whether the roll is driven by the moving yarn or cloth, or either of the latter, or carried forward by the former.

Secured near the stand *a'* on the shaft *d* is the gear *e*, which gears into and connects with the gear *e'*, this gear *e'* being firmly secured to the shaft *f*, which is furnished with the required bearings, formed in the stands *a'* and *b'*. Secured to this shaft *f*, near the bearing *b'*, is the worm-gear *f'*. Connecting with this worm-gear *f'* is the bevel-gear *g*, which is firmly secured to the shaft *g'*, this shaft being placed on an angle, as shown, and furnished with the required bearings, formed in the stand *c* and in the shell *h*, this shell *h* being provided with a suitable flange, *c''*, at one end, by which it is firmly secured to the stand *c'*, on its inner side.

Upon the inclined shaft *g'*, and near its upper end, is a movable and adjustable gear, *h'*, which gears into the dial-gear *i* and gives it motion. One side of the shaft *g'* is flattened, marked and figured as a gage, by which to set or adjust the gear *h'* to any circle of teeth on the dial-gear. This dial-gear *i* in the present instance consists of a disk or plate with several circular series of pins projecting from one side thereof, each series containing a different number of such pins, which, for convenience, are employed to represent the teeth of so many circular gears, which, when combined, would be the equivalent for the plate and pins, and would produce the same result in the same way. The outside series of pins or teeth contains five in number more than the series next within it, the number of teeth or pins in each series next within decreasing in the same proportion.

The dial-gear *i* is secured to one end of the shaft *i'*, and is supported by the hollow shaft *j* and the shell *h*, the latter secured to the stand *c'* by a flange, *c''*, as clearly shown in Fig. 2 of the drawings. A face or dial, *K*, is fastened to the outside of the stand *c'*, and a hand or pointer, *j*, passes through the end of the shaft *i'* near the face *K* of the indicator. This dial or face *K* has circular dividing-lines which correspond with the several series of pins or teeth on the dial-gear, and it is otherwise

marked and figured, as shown, to represent or indicate the number of yards of cloth, yarn, or warp measured. The hand or pointer *j* is movable transversely and adjustable in length by a set-screw in the end of the shaft, and is intended to be set with its pointed end opposite any circular line on the face of the clock, so as to indicate by pointing to marks or figures on such line the number of yards of cloth or warp which have at any time passed the device *d'* or roll. The hand or pointer not only serves the purpose above mentioned, but it holds the shaft *i* and the hollow shaft *j* in position longitudinally.

When the apparatus is altered or adjusted to indicate any number of yards of cloth or warp to be cut, which is done by moving the gear *k* on the shaft *g'* and into contact with some other series of teeth or pins on the dial-gear, then the pointer *j* is moved and its point adjusted to that circular line on the face of the indicator which corresponds with the circular series of teeth or pins in the dial-gear with which the gear *k* is engaged, and this insures the certain movement of the pointer to indicate the measurement of yards.

Secured to the hollow shaft *j*, at its end near the dial-gear *i*, is the reducing-gear *k'*, which connects with the pinion *l'*, which is secured to the gear *l*, this gear *l* being provided with the requisite stud and bearings, which are secured to the end of the shell *h* and connect or gear into the pinion *m*, the latter being secured to the face of the dial-gear *i*, the shell *h* forming the required bearing for the shell-shaft *j*, through which it passes. On its end is secured the finger or pointer *m'*, which indicates or points out on the dial *o* the number of cuts to the web or beam. *n* is the stop-pin upon the back of the dial-gear *i*, which, when the pointer *j* travels the entire circumference of the outside dial, *k*, or while the pointer *m'* moves from one notch to another, operates the shipper, thus stopping the machine and allowing the operator to put in the cut-mark as required. This stop-pin *n* is of some importance when the indicator is used on a dresser. In the use of the common machine-indicators the manufacturer is subjected to many serious difficulties, especially when applied to dressers which indicate the measurement required on the same, as there are frequent changes of the number of yards of warp to the cut.

When the manufacturer requires a change in the number of yards of warp to the cut, with the use of the common indicators, they have to be taken apart and other gears substituted to make this change, which, if but for five yards, (more or less,) results in a great inconvenience and loss of time to the manufacturer, besides involving the necessity of keeping on hand a large lot of gears of various sizes to effect this change, and in many instances even this does not render the apparatus capable of accurate measurement. The indicators now in common use having but a simple dial, which indicates the number of yards

only of warp dressed, the overseer is obliged to keep his account daily in order to settle with the operatives. The operative, with the use of such indicator, can attend to but one machine to any advantage to the manufacturer, as the cut-marks have to be put in at just such a place or at the end of so many yards. These several serious difficulties are fully obviated by our improved indicator, which being thus constructed and applied to the appropriate machine and its several parts adjusted in position, is ready for use, motion being given to the same by aid of the material passing over the device *d'* or drum or roll, which, by aid of the gear *e*, communicates motion to the gear *e'*, giving the required motion to the worm-gear *f'*, transmitting the same to the gear *k'* by aid of the gear *g*, which revolves the dial-gear *i* and the shaft *i'*, to which the pointer *j* is secured, at the same time by aid of the pinion *m*. Reduced motion is communicated to the shell-shaft *j* by aid of the reducing-gears *k* and *l*, carrying with it the pointer *m'*. Thus while the pointer *j* is traveling once around the entire circumference of the dial *k* the pointer *m'* moves but one notch on the dial *o*, thus giving the required number of yards of warp dressed, and also the number of cuts. At the same time when the pointer *j* travels around the entire circumference of the dial *k* the pin *n* is brought into contact with the shipper, which detaches the driving device, thereby stopping the machine, where it remains at rest until the operative puts in the cut-mark. The machine is again set in motion and performs the same operation, as before stated. The overseer at a glance at the dial *o* can ascertain at any time the number of cuts of warp finished at the end of every day, week, or month, and also the number of yards over, (more or less.) When the overseer receives his orders to have any given number of yards of warp to the cut, by aid of the adjustable gear *k'* and the figured gage *p* on the shaft *g'* he is enabled to change the same at a moment's notice without taking the same apart or substituting any different gear.

A bevel-gear could be substituted for the dial-gear *i*, and a series of gears forming a cone-gear could be substituted for the adjustable gear *k'* and the same results be accomplished; but we prefer the dial-gear *i* and the gear *k'*, as shown in the drawings, which we consider the best and most simple mechanism for the purpose.

This device, when applied to cotton machinery, we inclose in a metallic case, thus keeping the working parts entirely free from dust, dirt, &c. Thus it will be seen that with our improvements we are enabled to furnish a machine that will accurately indicate all the measurements required on a dresser, loom, or spinning-frame without taking apart or changing the gears thereof, as is unavoidably the case in the common indicators now in use. Besides furnishing a reliable, cheap, strong, and durable measure-indicator, convenient

and desirable, it furnishes a stop to the machine, which will prevent any liability of getting a greater or lesser number of yards in a cut than is required.

It will be observed that the teeth or pins of the dial-gear *i* are not in radial rows, except on the key-line A. (Seen in Fig. 4.) Any change or adjustment of the gear *h'* from one series of pins or teeth to another should be made on this key-line, or radial row of pins or teeth, which is designed in the construction of the dial-gear, and in the arrangement of the teeth or pins, for the special purpose of the easy and certain adjustment of the gear *h'*, which would be difficult, uncertain, or quite impossible on any other radial line or part of the dial-gear.

We will here state that in measuring cloth as it is woven, or yarn as it is spun, or either, as otherwise fabricated, or to indicate and register the measurement of such cloth or yarn while in the state of progressive fabrication, and in the construction and arrangement of devices or mechanisms for indicating the accurate measurement or lengths of fabrics, yarns, or threads during such fabrication by the usual process, and in order that several or single quantities or pieces of cloth or yarn, or portions thereof, may have accurate and positive given or desired beginnings and endings indicated, (the ending of one portion being the beginning of the next,) which are necessary, whatever may be the length of each successive portion indicated, it is also necessary that the device or mechanism which controls or regulates such indicated measurement and such beginnings and endings of measurements or lengths should be so devised, constructed, and arranged that any and all changes and adjustments made to indicate different and less or greater lengths or measurements be made on one particular line or part of such controlling or regulating device, and on no other part thereof.

To accomplish the objects last above described, we construct the dial-gear *i* and arrange the teeth or pins thereof as clearly shown in the drawings, and, as before described, the head-pin in each row of such pins being on a line, and forming one radial row or a key-line, A. Now, it will be seen and understood that this key-line A or single radial row of pins is a matter of necessity, and not of choice, for where several successive circular series of pins or teeth are arranged one beyond another, as here shown each successive outer series must contain a greater number of such teeth than the series next within, and this makes the pitch of the pins or teeth in each series equal to or the same pitch of the teeth of the pinion which meshes into such teeth, otherwise they would not mesh together; and if all the pins or teeth were in radial rows only one circular series could be made to fit the pinion, since the same number of teeth to the inch are absolutely required in each circular series as in the pinion, and only one se-

ries of pins or teeth in any number of radial rows could possibly be available without changing the pinion or substituting a coarser or a finer toothed pinion when changing from one circular series of pins to another. Where the teeth or pins in each circular series are arranged promiscuously, or without regard to any one radial row or key-line for the ready and certain adjustment of the pinion, then the teeth or pins in each series must come opposite some portion of the spaces in each adjacent series; and this would render the moving of the pinion from one series to another exceedingly difficult, uncertain, or quite impossible, as any attempt to move the pinion from contact with the teeth of one series to the teeth of another would bring the pinion-teeth into contact with the teeth, instead of into the spaces between the teeth on the dial-gear.

We are aware that one end of the pinion-shaft might be movable by an adjustable box or bearing, and that by releasing this bearing the pinion could be lifted from one series of pins or teeth and placed in another series; but this would be objectionable, as such random adjustments would prevent accurate measurement, and no two portions of yarn or pieces or portion of fabric would be of the same length. Our dial-gear *i*, constructed as shown and described, with several circular series of teeth or pins, and each series beginning on a line which forms a radial row of pins or a key-line, A, on which to adjust the pinion for the certain indication of uniform lengths or measurement of yarn or cloth, is, in our opinion, the best and most reliable means for that purpose. We therefore disclaim all other devices which have not this principal and peculiar construction and this arrangement of teeth or pins; but

What we do claim, and desire to secure by Letters Patent, is—

1. The combination and arrangement of the gears *e e*, operated by the drum-shaft *d*, the gears *f' g*, and the variable gears *h' i*, with a suitable reducing-gear and index or indexes for measuring and indicating any desired lengths of yarn of warp, or of cloth, substantially in the manner shown and described.

2. In combination with the dial-gear *i* and the adjustable gear *h'*, the graduated shaft *g'*, for indicating the position of the said adjustable gear, and thus forming a gage of the scale of movement of the measuring apparatus, substantially as described.

3. In combination with the dial-gear *i*, the stop-pin *n*, for disengaging the driver and stopping the machine whenever the desired or predetermined lengths have been measured, substantially as described.

JOHN A. BRADSHAW.  
SELDON L. CROCKETT.

Witnesses:

JOHN E. CRANE,  
WM. H. BROWN.