

*W. R. Thomas,
Casting Car Wheels.*

N^o 70,290.

Patented Oct. 29, 1867.

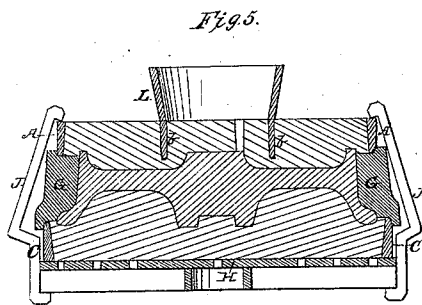
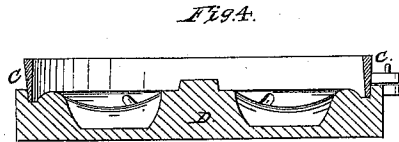
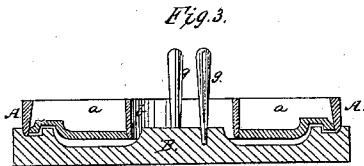
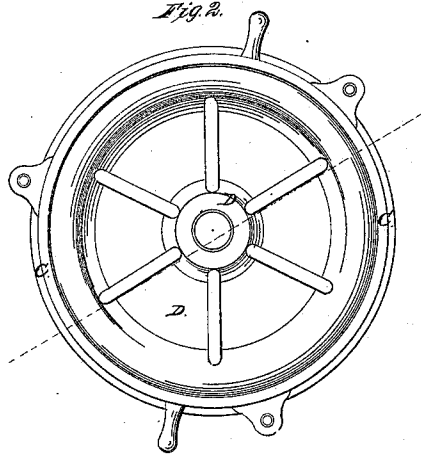
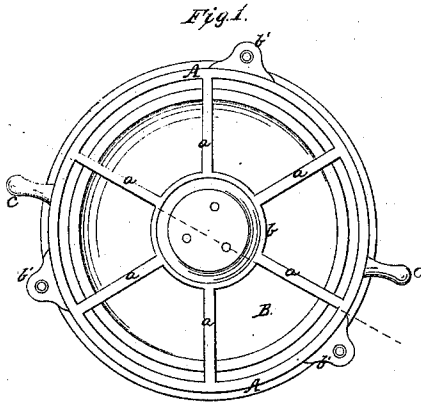

Witnesses:
Edu Schuyler,
J. W. Kingston.

Inventor:
W. R. Thomas
by
Mason Heinrich Hammer.

United States Patent Office.

W. R. THOMAS, OF CATASAUQUA, PENNSYLVANIA.

Letters Patent No. 70,290, dated October 29, 1867.

IMPROVEMENT IN FLASKS FOR CASTING CAR-WHEELS.

The Schedule referred to in these Letters Patent and making part of the same.

TO WHOM IT MAY CONCERN:

Be it known that I, W. R. THOMAS, of Catasauqua, in the county of Lehigh, and State of Pennsylvania, have invented a Mode of Casting Car-Wheels; and I do hereby declare that the following is a full, clear, and exact description thereof, reference being had to the accompanying drawings, making part of this specification, in which—

Figure 1 is a top view of the flask for producing the mould in sand of one side of a car-wheel.

Figure 2 is the flask for producing in sand the opposite side of the wheel.

Figures 3 and 4 are sectional views of the flasks of figs. 1 and 2.

Figure 5 is a diametrical section through the mould complete, showing a car-wheel cast in the same.

Similar letters of reference indicate corresponding parts in the several figures.

The object of this invention is to produce cast-metal car-wheels with chilled rims or peripheries in a more perfect and expeditious manner than has hitherto been effected, and to this end the nature of my invention consists in producing the wheels in moulds composed of sand and metal in such manner that the sand-moulds which produce the sides of the wheels are made in separate flasks, after which they are applied to a metal ring which produces the rim of the wheel, and at the same time chills and hardens it, as will be hereinafter described.

To enable others skilled in the art to understand my invention, I will describe its construction and operation.

In the accompanying drawings, A represents that portion of the cope or flask in which one side of the mould is produced in sand. It is constructed with radial strips, *a a*, secured at their inner ends to a concentric ring, *b*, and provided with perforated lugs *b'* and handles *c*, as shown in fig. 3. This flask or cope A is fitted upon a pattern, B, by means of studs on the latter entering the perforations through the lugs *b'*, and sand is rammed into said flask in the usual manner of making moulds for casting, after which the flask is removed and placed upon a metal chilling-ring, as shown in fig. 5. The flask C is designed for producing the mould in sand for the opposite side of the wheel, and in conjunction with this flask the pattern D is used, as shown in figs. 2 and 4. When this latter mould is produced, a bottom board, H, is placed on top of the flask C, and so as to turn it over in a position for receiving the chilling-ring and upper portion of the sand-mould upon it, as shown in fig. 5. The chilling-ring G is constructed with rebates on its upper and lower edges, which receive the edges of the flasks, as shown in fig. 5, and by means of the clamps J J the several parts composing the mould are firmly held together. The sprue-holes are made by the pins *g g*, shown in fig. 3, which pins are removed and a gate-box or pouring-gate, L, applied previously to pouring the metal into the mould. It will be seen by reference to fig. 5, that the upper and lower portions of the mould are composed of sand, and that these sections are made separately, that is to say, they are prepared in separate flasks, after which they are applied to the metal chilling-ring G, which forms the intermediate section of the mould, and produces the periphery of the wheel, at the same time chilling it, and rendering it very durable.

I am aware that the peripheries of car-wheels have been chilled in the act of producing the wheels previously to my invention, and therefore I do not claim broadly casting car-wheels with chilled peripheries.

What I claim as new, and desire to secure by Letters Patent, is—

The metal ring G, constructed with both an upper and lower shoulder for upper edge of the flask C, and lower edge of flask A to bear against, in combination with said flasks and with the clamps J J, constructed and applied as shown, all substantially as described.

Witnesses:

P. CLAY HAMERSLY,
J. W. FULLER, Jr.

W. R. THOMAS.