

April 10, 1951

C. G. TRANEFORS

2,548,753

BOOT OR THE LIKE

Filed Aug. 28, 1950

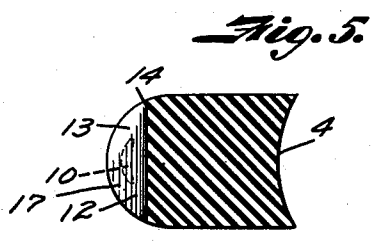
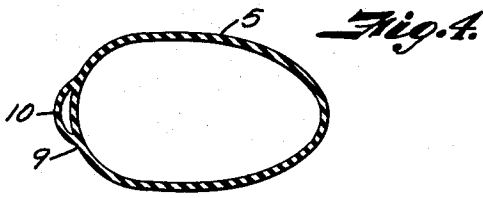
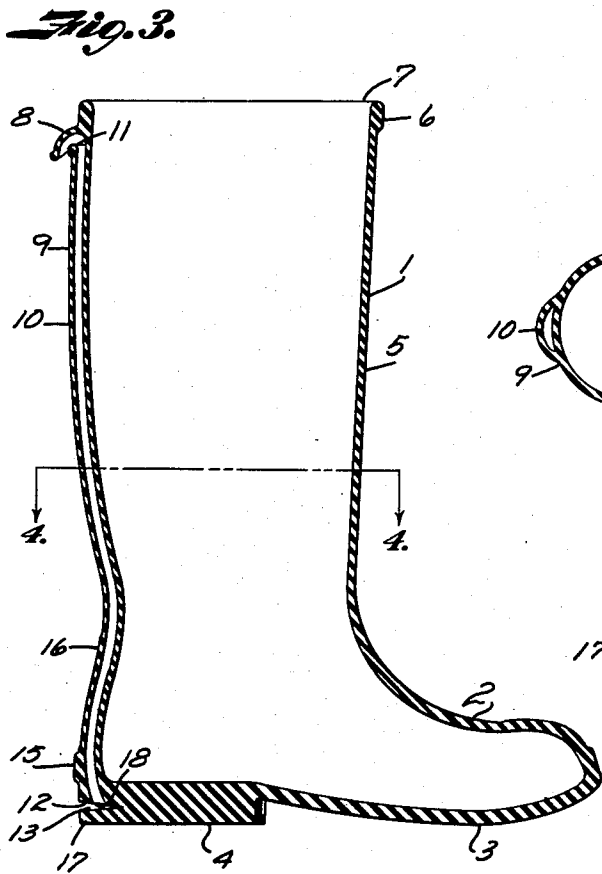
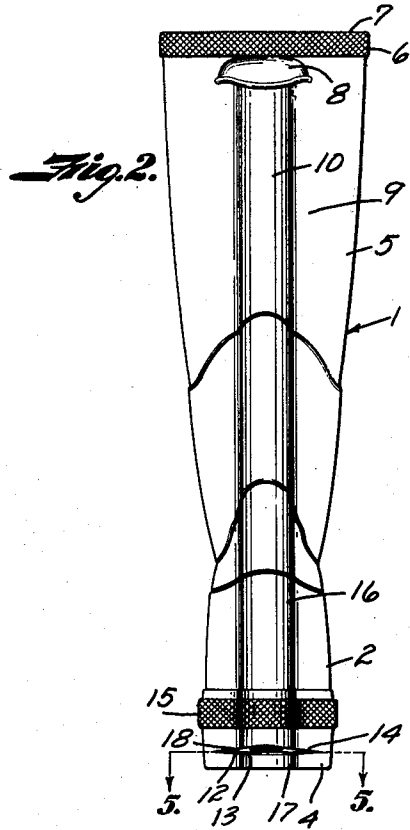
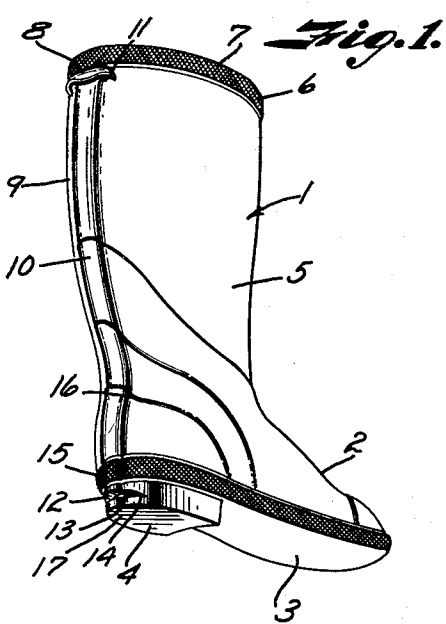

INVENTOR.
Carl Gustaf Tranefors
BY
Fickburn & Muller
ATTORNEYS.

UNITED STATES PATENT OFFICE

2,548,753

BOOT OR THE LIKE

Carl Gustaf Tranefors, Goteborg, Sweden, assignor to Elmer C. Rhoden, Kansas City, Mo.

Application August 28, 1950, Serial No. 181,854

3 Claims. (Cl. 36—1)

1 This invention relates to improvements in boots or the like, and has for its principal object to prevent a vacuum or suction effect created under the bottom or sole of the boot when walking in mud, clay, or mossy ground.

With ordinary boots or high top shoes, there is a tendency for the bottom of the shoe to suck when used in mud, clay or mossy ground, or in mud covered with water which is often the case with hip boots when the wearer is walking in water due to a vacuum being created under the boot sole when lifting the boot. The present invention is designed to obviate this undesirable feature in wearing boots or high top shoes.

Other objects of the invention are to provide a boot or shoe which will readily follow the foot when walking in mud, clay or mossy ground ordinarily having a tendency to create a vacuum or sucking action; to provide a boot of this character having a heel with a slit or recess forming a pocket in the rear thereof connecting with a tube extending upwardly from the pocket in the boot heel to a point near the top of the boot; to provide a heel for the boot which will act as a valve for the vent tube to break the vacuum created by the sucking action; and to provide a device of this character simple, economical to manufacture, and efficient in operation.

In accomplishing these and other objects of the present invention, I have provided improved details of structure, the preferred form of which is illustrated in the accompanying drawings, wherein:

Fig. 1 is a perspective view of a boot embodying the features of my invention.

Fig. 2 is a rear view thereof.

Fig. 3 is a vertical sectional view through the boot.

Fig. 4 is a cross-sectional view taken on a line 4—4, Fig. 3.

Fig. 5 is a cross-sectional view taken on line 5—5, Fig. 2, through the heel of the boot.

Referring more in detail to the drawings:

1 designates a boot embodying the features of my invention comprising a foot portion 2 having a sole 3, heel 4, leg portion 5 and top portion 6. The top 6 of the boot is provided with a rounded upper edge with a reinforcement 7 and the rear of the boot has a bracket or finger hold 8 for use in pulling the boot on the foot as is the usual practice. The finger hold 8 may be formed integrally with the top of the boot or otherwise secured thereto.

2 Extending vertically along the rear edge 9 of the boot is a passageway 10 which may be formed integrally with the boot or otherwise suitably secured thereto. The upper end is open as indicated at 11 and terminates under the finger hold 8 as best illustrated in Fig. 3. The rear portion of the heel of the shoe has a slit or slot 12 and is open to the outside of the heel. The slot extends substantially across the rear portion of the heel as best illustrated in Fig. 5, but not to the side edges thereof, and inwardly towards the front portion of the heel a substantial distance as indicated at 14. The upper face of the slit is hollowed out forming a pocket 13. The lower end of the passageway 10 terminates in the pocket or slotted portion of the heel and forms a passage from the outer portion of the heel to the upper end of the passageway.

20 The lower portion of the boot adjacent the heel may be reinforced as indicated at 15 and double strength around the ankle portion as indicated at 16, if desired, as is the usual practice.

25 When walking in mud, clay or mossy places or any similar soft place, a vacuum or suction is created under the heel 4 of the boot, as well as under the arch portion 16, and unless this vacuum is relieved, the boot will tend to pull away from the foot of the wearer, but when air is admitted under the heel of the boot or under the arch part of the sole, this vacuum will be alleviated to facilitate lifting of the boot from the mud.

35 In use of a boot constructed as described, the weight of the wearer on the boot in the mud will cause the opening 13 in the heel thereof to close, i. e. the flexible portion 17 will press upwardly against the underside 18 of the opening to close the opening. When the foot is lifted, the suction will cause the flexible heel portion to be flexed downwardly opening the opening 13 to allow air to pass down through the passage 10 under the heel and arch portion of the boot to release the vacuum that is formed thereabout.

45 It will be obvious from the foregoing that with the above improvements increased endurance may be attained due to lighter walking, noiseless walking on wet, mossy ground may be accomplished; wearing of hose is reduced and sore feet is greatly eliminated.

50 It will be obvious that the boot or shoe may be made from any suitable material, but preferably of rubber, although I do not wish to

3

be limited to that particular material, and it will be further obvious that the invention need not be limited to the form above described but may be changed without departing from the spirit of the invention.

What I claim and desire to secure by Letters Patent is:

1. A boot of the character described comprising, a foot portion, a heel and top portion, a pocket in said heel, and an air passageway extending upwardly along the back of said boot having its lower end opening into said pocket and its upper end terminating along said top portion, said opening in the heel extending substantially across the rear portion thereof forming a flexible portion on said heel adjacent said passageway whereby said flexible portion will act as a valve to open and close said passageway when the boot is in use.

2. A boot of the character described comprising, a foot portion, a heel and top portion, a finger hold on the rear of the top portion, a slot extending horizontally into the rear of said heel forming a pocket therein, and an air passageway extending upwardly along the back of said boot having its lower end terminating in said pocket and its upper end underneath said finger hold, said pocket extending forwardly of said opening of the passageway forming a flexible

4

portion on said heel adjacent said passageway whereby said flexible portion will act as a valve to open and close said passageway when the boot is in use.

3. A boot of the character described comprising, a foot portion, a heel and top portion, a finger hold on the rear top portion, a slot extending horizontally into the rear of said heel forming a pocket in said heel communicating with said slot, and an air passageway extending upwardly along the back of said boot having its lower end terminating in said pocket and its upper end underneath said finger hold, said slot extending forwardly of said opening of the passageway and said pocket forming a flexible portion on said heel adjacent said passageway whereby said flexible portion will act as a valve to open and close said passageway when the boot is in use.

CARL GUSTAF TRANEFORS.

REFERENCES CITED

The following references are of record in the file of this patent:

UNITED STATES PATENTS

Number	Name	Date
2,402,334	Marks	June 18, 1946