

No. 28,751.

PATENTED JUNE 19, 1860.

W. A. HERRICK.  
COUPLING AND UNCOUPLING CARS.

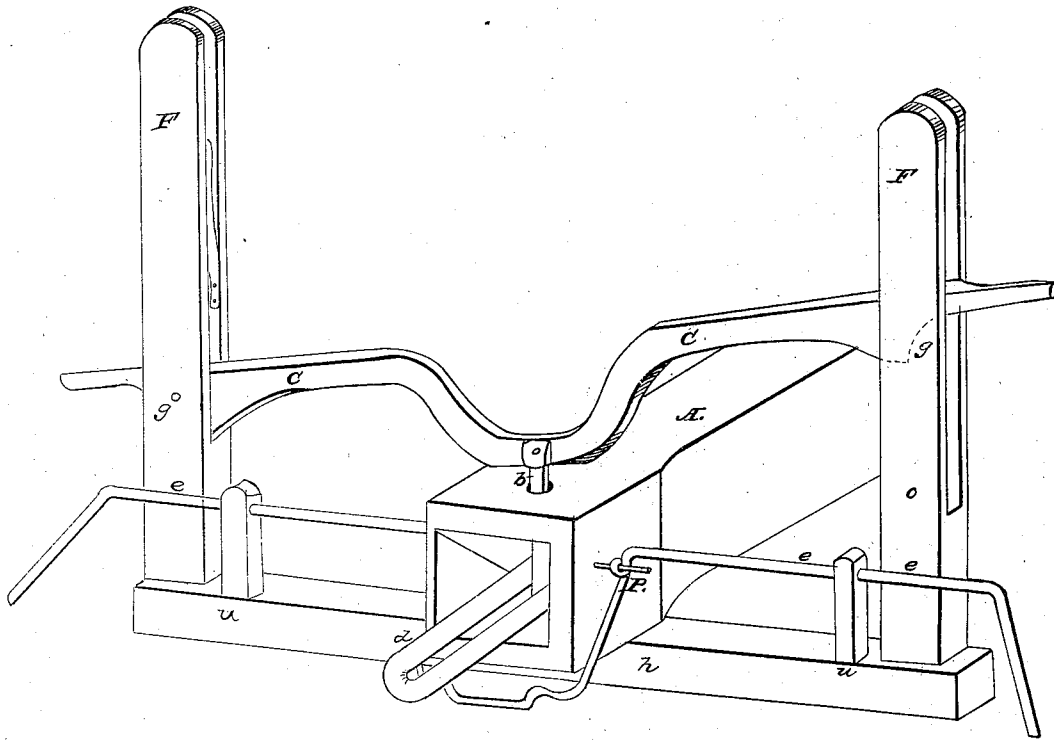

# UNITED STATES PATENT OFFICE.

WILLIAM A. HERRICK, OF LEEDS, MAINE.

## COUPLING AND UNCOUPLING CARS.

Specification of Letters Patent No. 28,751, dated June 19, 1860.

*To all whom it may concern:*

Be it known that I, WILLIAM A. HERRICK, of Leeds, in the county of Androscoggin and State of Maine, have invented a new and Improved Mode of Coupling and Uncoupling Cars; and I do hereby declare that the following is a full and exact description thereof, reference being had to the accompanying drawings and to the letters of reference marked thereon.

A, is the draw-bar.

b, is the shackle bolt.

c, c, is the lever for lifting and depressing the shackle bolt. This lever is curved downward in its middle part, where it is attached to the bolt, as shown in the drawing. The other ends pass through slots in the upper half of uprights F, F, attached to a cross bar or supporter h, said supporter being fastened to draw-bar by bolts. On one side of each slot is placed a spring which serves to hold the lever up, when it is raised to lift the bolt. There is a notch cut in the under part of the lever within the slot as shown by the dotted line at g. This notch when the lever is depressed rests upon a pin passing through the lower part of the slot.

d, is the link or shackle, one end held in its place by the bolt b, and the other hanging downward by its weight.

e, e, e, is a bent lever of round iron. This

lever may be called the adjusting lever. It has bent handles at each end, as represented, which act somewhat like cranks. The body of it is held in place by passing through small uprights u, u. Near the draw-bar the rod is twisted so as to make an eye, which plays on pin p, projecting at right angles to the sides of the draw-bar, on which pins it slides backward and forward at the will of the operator. The rod is then bent into a U form passing under the link or shackle. The office of this bent lever is to adjust the link, or shackle when coupling cars together. By turning the lever up or down, you elevate or depress the shackle and by sliding the lever, to, or from you, the shackle is moved to one side, or the other, and thus to the proper position for entering the cavity, or socket of the opposite draw-bar—all to be performed by the operator standing outside of the cars therefore out of harm's way.

What I claim as my improvement and for which I ask an exclusive right, is—

The combination and arrangement of the levers c, c, and e, e, constructed and operating substantially as described in the specification.

WILLIAM A. HERRICK.

Witnesses:

A. HERRICK,  
F. W. RIDLEY.