

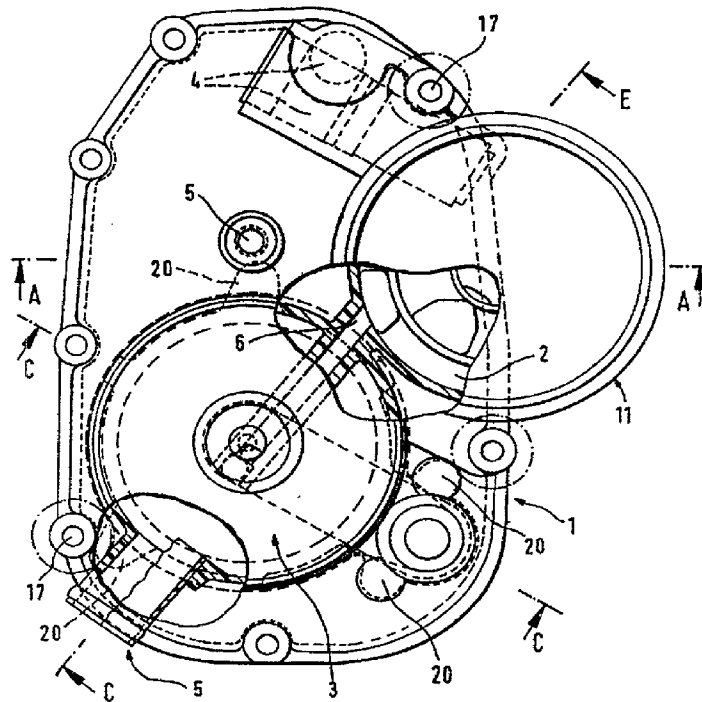

(72) SCHETTER, Martin, DE
(71) FILTERWERK MANN & HUMMEL GMBH, DE
(51) Int.Cl.⁶ F01M 1/10, F01M 11/03
(30) 1996/02/20 (196 06 182.2) DE
(54) **DISPOSITIF SEPARATEUR**
(54) **SEPARATOR**



(57) L'invention concerne un dispositif destiné à séparer les impuretés de l'huile lubrifiante d'un moteur à combustion interne, ce dispositif (1) comprenant au moins une cartouche filtrante (2), une centrifugeuse entraînée par la circulation de l'huile et au moins un conduit d'amenée (4) pour l'huile à purifier et au moins un conduit de dérivation (5) pour l'huile purifiée. La cartouche filtrante (2) et la centrifugeuse entraînée par la circulation d'huile lubrifiant sont disposées dans des boîtiers séparés, reliés par au moins un conduit d'huile communicant (6).

(57) The description relates to a device for separating impurities from the lubricating oil of an internal combustion engine, in which the device (1) has at least one filter insert (2), a centrifuge operable by the flow of lubricating oil and at least one discharge channel (5) for cleaned oil, in which the filter insert (2) and the centrifuge operable by the flow of oil are in separate housings linked by at least one communicating oil channel (6).



PCT WELTORGANISATION FÜR GEISTIGES EIGENTUM
Internationales Büro
INTERNATIONALE ANMELDUNG VERÖFFENTLICHT NACH DEM VERTRAG ÜBER DIE
INTERNATIONALE ZUSAMMENARBEIT AUF DEM GEBIET DES PATENTWESENS (PCT)

<p>(51) Internationale Patentklassifikation ⁶ : F01M 1/10, 11/03</p>	<p>A1</p>	<p>(11) Internationale Veröffentlichungsnummer: WO 97/31180 (43) Internationales Veröffentlichungsdatum: 28. August 1997 (28.08.97)</p>
<p>(21) Internationales Aktenzeichen: PCT/EP97/00537 (22) Internationales Anmeldedatum: 6. Februar 1997 (06.02.97) (30) Prioritätsdaten: 196 06.182.2 20. Februar 1996 (20.02.96) DE (71) Anmelder (für alle Bestimmungsstaaten ausser US): FILTERWERK MANN+HUMMEL GMBH [DE/DE]; Hindenburgstrasse 37-45, D-71631 Ludwigsburg (DE). (72) Erfinder; und (75) Erfinder/Anmelder (nur für US): SCHETTER, Martin [DE/DE]; Flurweg 7, D-74354 Besigheim (DE). (74) Anwalt: VOTH, Gerhard; Filterwerk Mann+Hummel GmbH, Postfach 409, D-71631 Ludwigsburg (DE).</p>	<p>(81) Bestimmungsstaaten: BR, CA, CN, CZ, HU, JP, KR, MX, US, europäisches Patent (AT, BE, CH, DE, DK, ES, FI, FR, GB, GR, IE, IT, LU, MC, NL, PT, SE). Veröffentlicht <i>Mit internationalem Recherchenbericht. Vor Ablauf der für Änderungen der Ansprüche zugelassenen Frist. Veröffentlichung wird wiederholt falls Änderungen eintreffen.</i></p>	

(54) Title: SEPARATOR

(54) Bezeichnung: ABTRENNVORRICHTUNG

(57) Abstract

The description relates to a device for separating impurities from the lubricating oil of an internal combustion engine, in which the device (1) has at least one filter insert (2), a centrifuge operable by the flow of lubricating oil and at least one discharge channel (5) for cleaned oil, in which the filter insert (2) and the centrifuge operable by the flow of oil are in separate housings linked by at least one communicating oil channel (6).

(57) Zusammenfassung

Beschrieben wird eine Vorrichtung zum Abtrennen von Verunreinigungen aus dem Schmieröl einer Verbrennungskraftmaschine, wobei die Vorrichtung (1) wenigstens einen Filtereinsatz (2), eine mittels durchströmenden Schmieröls antreibbare Zentrifuge und mindestens einen Zuleitungskanal (4) für zu reinigendes Schmieröl und mindestens einen Ableitungskanal (5) für gereinigtes Schmieröl aufweist, wobei der Filtereinsatz (2) und die mittels durchströmendem Schmieröls antreibbare Zentrifuge in separaten, wenigstens mittels einem kommunizierenden Schmierölkanal (6) verbundenen Gehäusen befindlich sind.

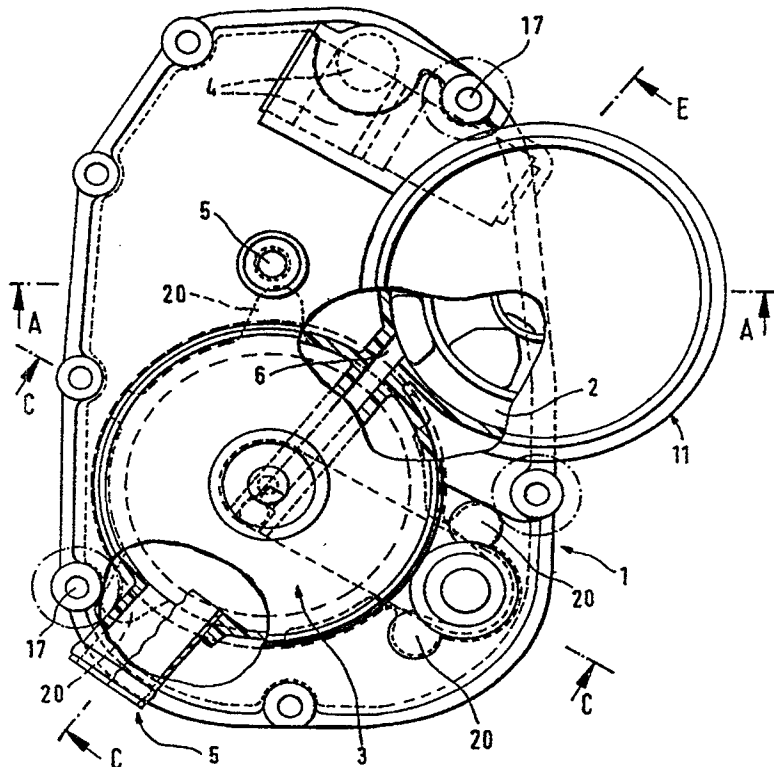

Separator Device

The invention relates to an apparatus for separating impurities from the lubricant oil of an internal combustion engine.

Such apparatus are known, for example in German Patent 43 06 431. If it is desired to use such apparatus, for example in crowded engine compartments of internal combustion engines, it is a disadvantage that often the necessary space is not available for it. It might be possible to mount such an apparatus outside of the engine compartment. This, however, is complicated, inasmuch as it would involve the additional expense of conduits and the necessary pumps; therefore it would increase the cost of the apparatus. But also the maintenance and the replacement of parts would make it impractical.

The invention is therefore addressed to the problem of improving an apparatus of the kind described above so as to have an apparatus which is easy to set up, flexible in application and design, as well as inexpensive.

This problem is solved by the invention by providing an apparatus comprising at least one filter insert, a centrifuge that can be driven by flowing lubricant oil, and at least one inlet passage for lubricant oil to be cleaned and at least one outlet passage for cleaned lubricant oil, wherein the filter insert and the centrifuge driven by flowing lubricant oil are located in separate housings connected by a communicating lubricant oil passage.

Thus it becomes possible to arrange the two functional units, filter insert and centrifuge, at nearly any desired place in the engine compartment of an internal combustion engine. Suitably, an effort should be made to keep the lengths of the flow passages short so as to keep the pressure losses low.

Advantageously, provision can be made for a pressure regulating valve to be contained in at least one of the communicating lubricant oil passages. This will assure for example that optimum working conditions will prevail in the centrifuge.

In an additional advantageous embodiment provision can be made for the centrifuge and/or the filter insert to be situated in the area of an operating element of the internal

combustion engine. This assures that so-called functional units can be formed, capable of acting in concert on elements involved in control, regulation and power. This applies in the same degree to housing walls that can be used in common.

Another advantageous embodiment provides that the functional element is the crankcase venting valve, which is suitable because of its geometrical configuration.

Advantageously it is possible to provide for the centrifuge and/or filter insert and the functional element to have at least one common housing side. By the formation of functional units that use, for example, common housing sides, a weight-saving effect can be achieved. The spatial requirements can thus also be reduced.

Another advantageous embodiment provides for the longitudinal axes of filter and centrifuge to be arranged parallel to one another.

In another advantageous embodiment of the invention, the filter is removable and replaceable with the filter housing open. This facilitates maintenance and filter element replacement.

In another advantageous embodiment, the passage feeding the apparatus is the same as the passage feeding the centrifuge. In this variant the centrifuge is operated on the raw oil side.

In another advantageous embodiment of the invention, the outlet passage of the apparatus is the same as the passage feeding the centrifuge. In this case the centrifuge is operated on the clean oil side.

These and other features of preferred embodiments of the invention will be found not only in the claims but also in the description and the drawings, it being possible for the individual features to be realized individually or together in the form of sub-combinations in the embodiment of the invention and in other fields, and can be advantageous as well as independently patentable embodiments for which protection is hereby claimed.

Embodiments of the invention are depicted in the drawings and are further explained

below. The drawings show:

Figure 1 a top view of the apparatus,

Figure 2 a view from below,

Figure 3 a section along line C-C,

Figure 4a, b a section along line A-A,

Figure 5 a section along line C-E,

Figure 6a, b a section along line C-E.

The apparatus 1, which is shown in Figures 1 and 2, comprises a filter insert 2, which is to be seen in Figures 1, 4a and 4b, and a centrifuge rotor 10 illustrated in Figure 3, which, as shown in Figure 1, are connected together by a communicating lubricant oil passage 6. The apparatus 1 is fastened to the internal combustion engine by means of housing mounting bores 17 and screws not shown. Both the filter insert 2 and the centrifuge rotor 10 are situated in separate housings. The housing 11 of filter insert 2, which is shown in Figures 1, 2, 4a and 4b, has an inlet passage 4 shown in Figures 1, 2 and 4b, through which raw oil enters in the case where the centrifuge is fed on the clean oil side, and the raw oil, after passing the filter insert 2, flows through the communicating lubricant oil passage represented in Figures 1, 2, 3, 5 6a and 6b, into the centrifuge rotor 10 through the inlet 22 integrated into the centrifuge shaft 24 and arrives at the inlet opening 28 provided in the centrifuge rotor 10 and shown in Figure 3. It is also shown in Figure 3 how the oil entering the centrifuge rotor 0 is carried through a hollow centrifuge shaft 24, whereby the centrifuge shaft 24 is anchored in the centrifuge housing 3 and centrifuge housing cover 21 such that, in connection with the sealing centrifuge bearing 25 the oil can pass only through the centrifuge rotor nozzle 26 into the space surrounding the centrifuge rotor in the centrifuge housing 3. From there the filtered and centrifuged oil leaves the apparatus 1 through the outlet passage 5 situated on the housing 3 and represented in Figures 1, 2, 3, 4a, 4b, 6a and 6b, doing so without pressure.

The centrifuge housing 3 is arranged on the internal combustion engine in such a manner, as represented in Figure 3, that the crankcase venting valve 8, which has a coil spring 13 communicating with a valve plate 23 and shown also in Figures 5 and 6a, and is vented through the vent passage 12 shown in Figures 2, 3, 5 and 6a, and the centrifuge housing 3 have a common housing wall 9, which is additionally visible in Figures 5 and 6a. The crankcase housing vent valve 8, which is additionally shown in Figures 5, 6a and 6b, has contact, through connecting opening 14 which appears in Figure 3, with the crankcase, not shown, of the internal combustion engine. The centrifuge housing 3 is fastened to the apparatus 1 by means of the centrifuge housing fasteners 20 shown in Fig. 1 and Fig. 2. Both the housing 11 of filter insert 2, and that of centrifuge 3 can be opened (Figs. 3 and 4) such that, after both the filter housing cover 16 represented in Figures 4a and 4b and the centrifuge housing cover 21 are removed, the filter insert 2 or centrifuge rotor 10 can be removed from their open housings and replaced. The housing covers 16 and 21 are fastened to the housings by means of screws or snap fasteners, such that in the operating state no oil can leave the housing interiors, as is represented for example by gasket 27 in Figure 4a.

In the lubricant oil passage 6 communicating with the housings of the filter insert 2 and the centrifuge 3 there is a pressure regulating valve 7 which is shown in Figure 5 and is in the form of a ball-and-spring valve.

In an alternative embodiment, the apparatus 1, as represented in Fig. 4b, has two filter inserts 2 which are accommodated in a single housing such that they can be exchanged after the housing is opened. The filter inserts 2 are sealed in the installed state by means of the filter gasket 19 represented in Figures 4a and 4b from the filter chamber drain opening 18 which is shown in Figure 2. When the filter inserts 2 are exchanged, the oil present in the filter chamber can flow back by gravity into the crankcase. The filter inserts 2 have, as shown in Figures 4a and 4b, filter by-pass valves 15 which prevent interruption of the oil pressure when the filter is clogged.

In another alternative embodiment, the centrifuge is fed on the raw oil side, as represented in Figure 6a. The feeding of the centrifuge fed on the clean oil side is shown for comparison in Figure 6b. In the embodiments described above the centrifuge is operated in a by-pass stream, the oil leaves the centrifuge by gravity, and the centrifuged oil flows for example into the oil pan, which is not shown.

Reference Numeral List

- 1 Apparatus
- 2 Filter Insert
- 3 Centrifuge Housing
- 4 Inlet Passage
- 5 Outlet Passage
- 6 Communicating Lubricating Oil Passage
- 7 Pressure Regulating Valve
- 8 Crankcase Ventilation Valve
- 9 Common Housing Wall
- 10 Centrifuge Rotor
- 11 Housing for Filter Insert
- 12 Venting Passage
- 13 Screw Spring
- 14 Connecting Opening
- 15 Filter Bypass Valve
- 16 Filter Housing Cover
- 17 Housing Attachment Bore
- 18 Filter Chamber Discharge Opening
- 19 Filter Seal
- 20 Centrifuge Housing Mount
- 21 Centrifuge Housing Cover
- 22 Feed
- 23 Valve Plate
- 24 Centrifuge Axis
- 25 Centrifuge Bearing
- 26 Centrifuge Rotor Nozzle
- 27 Seal
- 28 Feed Opening in Centrifuge Rotor

Article 34 Amendment

New Main Claim

Apparatus for separating impurities from the lubricant oil of an internal combustion engine, wherein the apparatus (1) has at least one filter insert (2), a centrifuge drivable by means of flowing lubricant oil, and at least one inlet passage (4) for lubricant oil to be cleaned and at least one outlet passage (5) for cleaned lubricant oil, the filter insert (2) and the centrifuge drivable by means of flowing lubricant oil being in separate housings connected by means of a communicating lubricant oil passage and arranged side by side, whose central axes are parallel and which have at least one common housing area (9).

AMENDED SHEET

