



(22) Date de dépôt/Filing Date: 2005/02/10  
 (41) Mise à la disp. pub./Open to Public Insp.: 2005/09/24  
 (45) Date de délivrance/Issue Date: 2009/07/07  
 (30) Priorité/Priority: 2004/03/24 (JP2004-086006)

(51) Cl.Int./Int.Cl. *F23D 1/00* (2006.01),  
*F23L 13/06* (2006.01), *F23N 3/04* (2006.01)

(72) Inventeurs/Inventors:  
 YAMAMOTO, KENJI, JP;  
 OKAZAKI, HIROFUMI, JP;  
 ITOU, OSAMU, JP;  
 TANIGUCHI, MASAYUKI, JP;  
 YANO, TAKANORI, JP;  
 KIYAMA, KENJI, JP;  
 KURAMASHI, KOUJI, JP

(73) Propriétaire/Owner:  
 BABCOCK-HITACHI K.K., JP

(74) Agent: KIRBY EADES GALE BAKER

(54) Titre : BRULEUR, METHODE DE COMBUSTION DE COMBUSTIBLE ET METHODE DE MODIFICATION EN RATTRAPAGE DE CHAUDIERE

(54) Title: BURNER, FUEL COMBUSTION METHOD AND BOILER RETROFIT METHOD

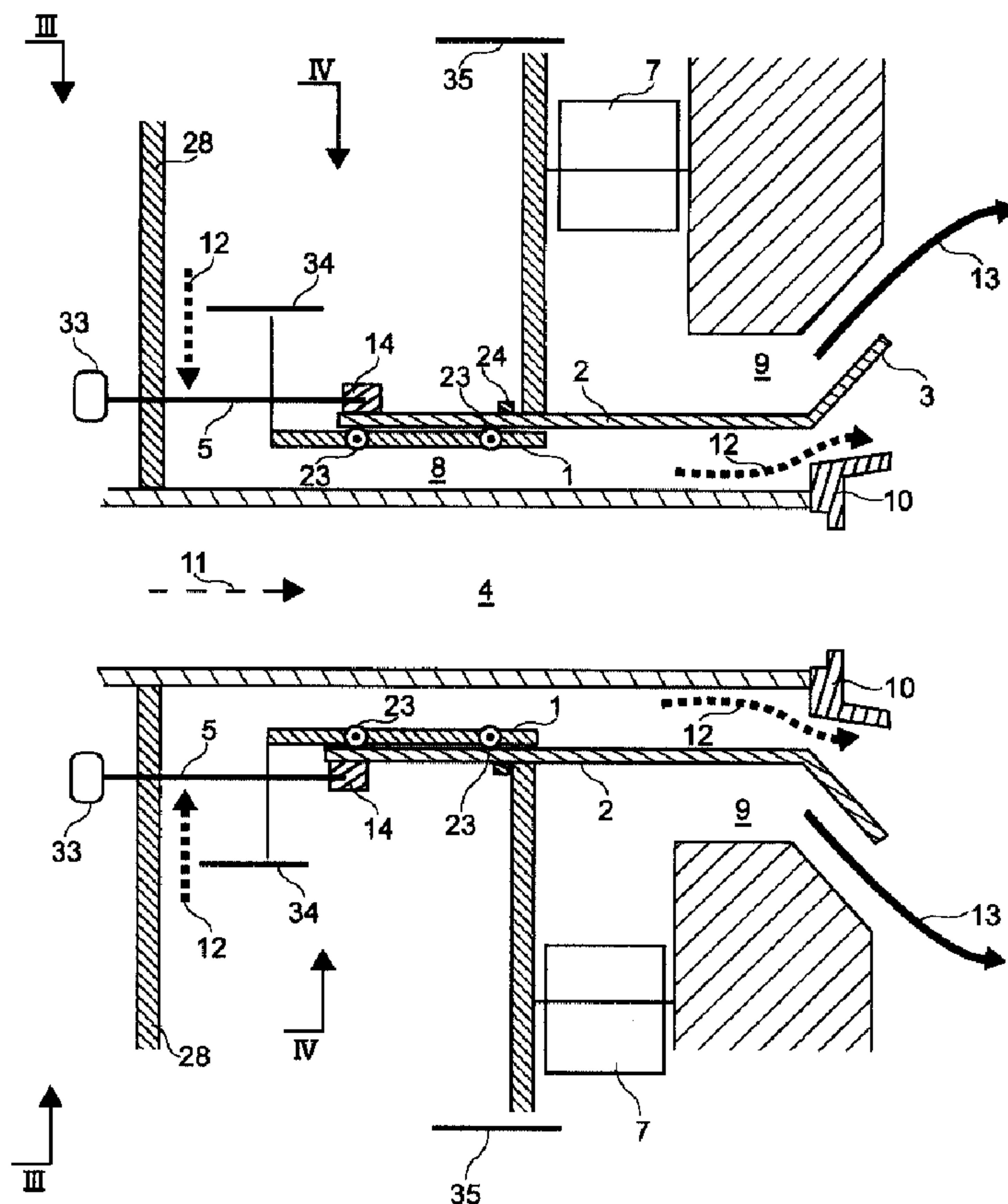

(57) Abrégé/Abstract:

A burner having a primary nozzle, a secondary nozzle and a tertiary nozzle, a partition wall partitioning the secondary nozzle and the tertiary nozzle and a flow path change member provided thereon. The partition wall is formed so as to be movable in parallel to

(57) **Abrégé(suite)/Abstract(continued):**

the burner axis to control jetting speeds and flow rates of secondary air and tertiary air whereby it is possible to cool the burner constituent members while reducing NOx. The partition wall is composed of a fixed wall and a movable wall. A bypass passage is formed through which tertiary air in the tertiary nozzle bypasses the tertiary nozzle to flow into the secondary nozzle or the primary nozzle.

**ABSTRACT**

A burner having a primary nozzle, a secondary nozzle and a tertiary nozzle, a partition wall partitioning the secondary nozzle and the tertiary nozzle and a flow path change member provided thereon. The partition wall is formed so as to be movable in parallel to the burner axis to control jetting speeds and flow rates of secondary air and tertiary air whereby it is possible to cool the burner constituent members while reducing NOx. The partition wall is composed of a fixed wall and a movable wall. A bypass passage is formed through which tertiary air in the tertiary nozzle bypasses the tertiary nozzle to flow into the secondary nozzle or the primary nozzle.

**BURNER, FUEL COMBUSTION METHOD AND  
BOILER RETROFIT METHOD**

**BACKGROUND OF THE INVENTION**

**TECHNICAL FIELD**

5           The present invention relates to a burner, a fuel combustion method by the burner, and a method of retrofitting a boiler provided with an existing burner.

**DESCRIPTION OF PRIOR ART**

10           For burners used for boilers or the like, it is required that they cope with load change, various coals, and reduce the concentration of nitrogen oxides (NO<sub>x</sub>), and unburned fuel, etc. In order to satisfy those requirements, various methods of controlling combustion conditions have been developed. For example, methods of apportioning a flow quantity of air between secondary air and tertiary air by air resistors, or changing swirl number, etc.

15           One method of controlling combustion conditions is by adjusting a secondary air flow rate and adjusting an air jetting direction by making a partition wall between secondary air and tertiary air movable as proposed in for example, Japanese Patent Document JP 60-26922 B published June 26, 1988.

20           JP 60-26922 B discloses that since it is possible to control the flow of secondary air by moving the partition wall in the burner axial direction, the secondary flame can burn under the best condition from a viewpoint of low NO<sub>x</sub> emission and combustion efficiency.

## SUMMARY OF THE INVENTION

Certain exemplary embodiments may provide a fuel combustion burner comprising a primary nozzle for supplying fuel and primary air, a secondary nozzle for supplying secondary air, provided outside said primary nozzle, and a tertiary nozzle for  
5 supplying tertiary air, provided outside said secondary nozzle so as to contact with the outside of said secondary nozzle, said secondary nozzle and said tertiary nozzle being partitioned by a partition wall, wherein: said primary nozzle has a stabilizer provided at an end thereof, said partition wall has thereon a flow path change member for  
10 changing a flow of tertiary air from a flow along an axis of the burner to an outward flow which jets the tertiary air, and said partition wall is movable in the burner axial direction allowing to a substantially closed condition of an outlet of said tertiary nozzle.

By moving the partition wall provided with the flow path change member in a direction parallel with the burner axis, a cross-sectional area of a tertiary air jet of the  
15 tertiary nozzle changes, and a flow rate and a flow speed of the tertiary air change. The change in flow rate of the tertiary air changes a flow rate and a flow speed of the secondary air. By the change in flow rate of the tertiary air or a flow rate of the secondary air, the combustion conditions change. As a result, it is possible to lower the temperatures of burner constituent components.

20 The burner of triple tube construction is constructed so that fuel is ignited with primary air to form a reducing flame and lower NO<sub>x</sub> emissions, and the secondary air and tertiary air are mixed with the reducing flame to burn the unburned fuel. The burner is known as an in-flame 2-stage combustion burner or an in-flame NO<sub>x</sub> reduction burner. In this burner, the delay in mixing of the tertiary air increases the  
25 region of the reducing flame, whereby low NO<sub>x</sub> emission is promoted. Many burners of this construction have a stabilizer provided at the outlet of the tubular primary nozzle, as shown in

JP 60-26922 B and in the present invention, also, it is possible to provide a stabilizer at the outlet of the primary nozzle. There is an inner flame stabilizing ring in which a ring-shaped projection is formed at the inside of the outlet of the tubular primary nozzle and an outer flame stabilizing ring in which a tubular projection is provided outside the outlet of the tubular primary nozzle in the burner axis direction. Provision of the stabilizer forms a flow recirculation region due to turbulent flow eddy in a wake flow thereof or in a flow downstream of the stabilizer. The flow recirculation involves fuel, for example, pulverized coal particles, to make them into flash points for high temperature gas and promote ignition of the pulverized coal. Here, the secondary air cools the stabilizer and adjusts a mixing ratio of fuel and air.

The flow path change member, that has a taper-shaped inclined plane so that the tertiary air flows, while changing gradually the flow direction from a flow parallel with the burner axis to an outward flow is desirable. The rear side, that is, the side in contact with the secondary air, of the flow path change member is desirable to be formed so that it is inclined along the plane of the tertiary nozzle. By forming the flow path change member in this manner, when the flow path change member is moved such that the tertiary air jet cross-sectional area becomes small, the secondary air jet cross-sectional area increases according to the movement thereof.

In order to make the partition wall move easily without making the burner construction complicated, it is desirable for the partition wall to be composed of a fixed wall and a movable wall, and for the movable wall to be slidable on the surface of the fixed wall. In addition, a portion of the tertiary air flows parallel with the burner axis and the fixed wall, as a portion of the parallel flow changes in direction outward as the movable wall, that is, the latter portion is a portion on which the flow path change member is provided. It is desirable for the fixed wall to provide guide rollers thereon. A stopper or stoppers may also be provided for stopping movement of the movable wall on the fixed wall and /or the movable wall. Since the flow path change member and the

partition wall in the vicinity of the flow path change member are apt to be heated to a high temperature, it is preferable to provide fins for cooling. As a means for moving the movable wall, a bar-shaped member is mounted on the movable wall for movement forward and backward in the burner axis direction by manual or automatic means.

5 Extension of one end of the bar-shaped member out of the wind box of the burner simplifies maintenance and reduces failure. The movable wall is moved by pulling and pushing the end of the bar-shaped member by hand. Further, it can easily be moved forward and backward by gears on the end portion of the bar-shaped member and a handle having another gear mounted thereon. Alternatively, by providing a motor or  
10 motors instead of the handle, it is possible to automatically move the moveable wall.

The burner according to the invention can be used for a burner using oil, gas, pulverized coal, etc. as fuel, particularly, it is suitable for a burner using pulverized coal. In a pulverized coal burner, sometimes combustion is assisted by providing an oil burner inside a primary nozzle.

15 For the burner according to an exemplary embodiment of the present invention, it is possible to add a tertiary air bypass mechanism by which a part of tertiary air is caused to bypass the tertiary nozzle into another nozzle. The tertiary air bypass mechanism is formed so that when the partition wall partitioning the secondary nozzle and the tertiary nozzle is moved to a predetermined position and a part of the tertiary air bypasses the  
20 tertiary nozzle into another nozzle. By making holes in the moveable wall and in the fixed wall so as to communicate with the above-mentioned hole when the movable wall is moved to the predetermined position, the part of the tertiary air can bypass the tertiary nozzle into the secondary nozzle. One hole formed in each of the fixed wall and the movable wall is sufficient. However, a plurality of holes in a circumferential direction  
25 can be provided in order to increase a flow rate of the tertiary air.

By forming a hole in the primary nozzle and connecting the hole with the hole formed in the fixed wall by a bypass pipe, it is possible to flow the tertiary air into the primary nozzle. By forming the bypass pipe so that the tertiary air flows along the inner wall of the primary nozzle and jets in the flow direction of fuel, it is possible to cool the stabilizer by the tertiary air flowing in the primary nozzle.

Certain exemplary embodiments may provide a fuel combustion method by a burner comprising a primary nozzle for supplying fuel and primary air, a secondary nozzle for supplying secondary air, provided outside said primary nozzle, a tertiary nozzle for supplying tertiary air, provided outside said secondary nozzle so as to contact with the outside of said secondary nozzle, a stabilizer provided at an end of said primary nozzle, said secondary nozzle and said tertiary nozzle being partitioned by a partition wall, and a flow path change member provided on said partition wall for changing a flow of the tertiary air from a flow along the burner axis to an outward flow, said partition wall being constituted to be movable in the burner axis direction, wherein: said partition wall is moved depending on one or more of a load change, a temperature at a burner axis end portion, properties of the fuel, a concentration of nitrogen oxides, a concentration of unburned fuel, and a fuel supply stoppage, said partition wall allowing adjustment of an outlet of said tertiary nozzle to a substantially closed condition. Preferably, a fuel combustion method, wherein at the time of stoppage of fuel supply to said burner, said partition wall is moved so that a cross-sectional area of a tertiary air jetting outlet of said tertiary nozzle becomes small, thereby increasing a flow rate of the secondary air from said secondary air nozzle. More preferably, a fuel combustion method, wherein said method further comprises step of moving said partition wall so that the cross-sectional area for jetting tertiary air of said tertiary nozzle decreases when a temperature of said flow path change member becomes higher than a set temperature during combustion of fuel by the burner, and increasing a flow speed of the tertiary air. Even more preferably, a fuel combustion method, wherein a part of the tertiary air supplied to said tertiary nozzle is caused to bypass a flow path of said tertiary nozzle into said secondary nozzle during stoppage

5a

of fuel supply to said burner. Still more preferably, a fuel combustion method, wherein a part of the tertiary air supplied to said tertiary nozzle is caused to bypass a flow path of said tertiary nozzle to flow along an inner wall of said primary nozzle during stoppage of fuel supply to said burner.

5           Certain other exemplary embodiments may provide a method of retrofitting a boiler having a burner which is provided on a furnace wall and comprises a primary nozzle for supplying fuel and primary air, a tubular secondary nozzle for supplying secondary air, provided outside said primary nozzle so as to enclose said primary nozzle, a tubular tertiary nozzle for supplying tertiary air, provided outside said  
10 secondary nozzle, a stabilizer provided at an end of said primary nozzle, a tubular partition wall fixed between said secondary nozzle and said tertiary nozzle, wherein said method comprises: removing at least an end portion of said partition wall; and providing, around the position of the removed portion of said partition wall, a tubular partition wall with a flow path change member for changing a flow of tertiary air from  
15 a flow along the burner axis to an outward flow so as to be movable in the burner axial direction, said tubular partition wall allowing adjustment of an outlet of said tubular tertiary nozzle to a substantially closed condition.

Still yet another aspect of the present invention is a method of reducing the tertiary air jet cross-sectional area to increase the momentum of tertiary air and increasing the quantity of tertiary air in the case where the NO<sub>x</sub> concentration is high or low combustibility fuel is used.

5 Another aspect of the present invention is a method of retrofitting a boiler provided with an existing burner having a tubular partition wall which partitions a secondary nozzle and a tertiary nozzle wherein a part or all of the partition wall is removed and a tubular partition wall provided with a flow path change member arranged so as the fixed partition wall is movable.

10 The burner according to an exemplary embodiment of the present invention is the in-flame 2-stage combustion type which provides for excellent reduction of NO<sub>x</sub>. It is possible to suppress ash deposit on the burner or damage of the burner due to heat while reducing NO<sub>x</sub>. By fixing the jet direction of tertiary air to a constant outward direction and changing the momentum of the tertiary air, the size or region of flow recirculation  
15 can be optimized, and it is possible to improve the combustion conditions. Even if a flow rate of tertiary air is kept constant, it is possible to make the flow speed at a downstream end of a guide sleeve high so that the guide sleeve can be cooled. By controlling independently the momentum and the flow rate of the tertiary air, the size of flame and the size of flow recirculation determined mainly by the momentum, and the size of a  
20 reducing region determined by the flow rate can be controlled independently, and favourable combustion conditions can be maintained.

#### **BRIEF DESCRIPTION OF THE DRAWINGS**

Fig. 1 is a sectional view of a burner of an embodiment of the present invention;

25 Fig. 2 is a sectional view showing the burner of the embodiment of the present invention shown in Fig. 1 in use;

Fig. 3 is a sectional view taken along III-III of the burner of Fig. 1;

Fig. 4 is a sectional view taken along IV-IV of the burner of Fig. 1;

Fig. 5 is a sectional view of the burner of another embodiment of the present invention;

5 Fig. 6 is a sectional view of the burner shown in Fig. 5 in use;

Fig. 7 is a schematic diagram of a construction of a controller for the burner according to the present invention;

Fig. 8 is a sectional view of the burner of another embodiment of the present invention;

10 Fig. 9 is a sectional view of the burner of another embodiment of the present invention;

Fig. 10 is a sectional view of the burner of another embodiment of the present invention;

15 Fig. 11 is a sectional view of the burner of another embodiment of the present invention;

Fig. 12 is a sectional view of the burner of another embodiment of the present invention;

Fig. 13 is a sectional view of the burner taken along XIII-XIII of Fig. 12;

Fig. 14 is a sectional view of the burner taken along XIV-XIV of Fig. 12;

20 Fig. 15 is a sectional view of the burner taken along XV-XV of Fig. 12;

Fig. 16 is a sectional view of the burner of another embodiment of the present invention;

Fig. 17 is a sectional view of the burner taken along XVII-XVII of Fig. 16;

Fig. 18 is a sectional view of the burner taken along XVIII-XVIII of Fig. 16; and

5 Fig. 19 is a graph showing conditions that the flow rates of fuel and air supplied from the burner change according to burner loads.

### **DETAILED DESCRIPTION OF EMBODIMENTS OF THE INVENTION**

The burner and the method of using the burner according to the present invention will be explained, referring to the Drawings.

#### **10 EMBODIMENT 1**

Figs. 1, 2, 3 and 4 are sectional views showing an embodiment of the burner according to the present invention. The burner has a triple tube construction composed of a primary nozzle 4, a secondary nozzle 8 and a tertiary nozzle 9. Primary air and pulverized coal flow from the primary nozzle 4 as shown by an arrow 11. In the present  
15 embodiment, the case where pulverized coal is used as fuel is shown, however, the case where oil, gas or the like is used is also the same as the above-mentioned case. The primary nozzle 4 is tubular and its cross-section is shaped in circle or square. A partition wall is provided between the secondary nozzle 8 and the tertiary nozzle 9, and the partition wall is composed of a fixed wall 1 and a movable wall 2. A guide sleeve 3 is  
20 provided at an end portion of the movable wall 2. The guide sleeve 3 serves to change the flow of tertiary air outwardly.

Secondary air flows from the secondary nozzle 8 shown by arrow 12. Further, the tertiary air flows from the tertiary nozzle 9 shown by arrow 13. The movable wall 2 is connected to movement control rods 5 at connection portions 14, and handles 33 for operating are provided out of a wall 28 of a wind box.

5 A stabilizer 10 having a tubular shape is provided on an end of the primary nozzle 4. An air resistor (or air resistors) 7 is provided upstream of the tertiary nozzle 9. Further, a tertiary damper 35 and a secondary damper 34 are provided upstream of the tertiary nozzle 9 and the secondary nozzle 8, respectively.

10 By moving the movable wall 2 and the guide sleeve 3 provided on the end thereof, forward and backward in a parallel direction to the burner axis, the flow rate and flow speed of the tertiary air, the flow rate and flow speed of the secondary air and a ratio of the tertiary air flow rate and the secondary air flow rate are changed whereby it is possible to control the combustion conditions. This is the same as changing a ratio of tertiary air momentum and secondary air momentum. In the present invention, by  
15 keeping a jet angle of the tertiary air constant and changing an outlet cross-sectional area for the tertiary air, it is possible to change the flow rate and flow speed of the tertiary air. By always directing the tertiary air outward, the size of the flow recirculation formed downstream of the stabilizer 10 and the guide sleeve 3 can always be increased so that the combustion conditions can be kept ideal. The momentum of the tertiary air is a main  
20 factor for determining the size of flame and the size of flow recirculation and the flow rate of the tertiary air is a main factor for determining the size of a reducing region. Since the momentum and the flow rate of tertiary air can be controlled independently, it is possible to make a combustion condition suitable for improving flame stabilization and NOx reduction. Further, it is possible to change independently the momentum of tertiary  
25 air and the flow rate of secondary air, whereby the secondary air can be used for cooling of the stabilizer 10, air supply to the fuel flowing in the primary nozzle, etc.

Fig. 3 shows a III-III sectional view of Fig. 1. Fig. 4 shows a IV-IV sectional of Fig. 1. Rollers 23 are mounted so that the movable wall 2 moves smoothly. In this embodiment, four (4) movement control rods 5 are provided, and they are suitable for parallel movement of the movable wall 2 to the burner axis. The rollers 23 are mounted on the fixed wall 1, but they also can be mounted on the movable wall 2.

The temperature of the movable wall 2 may rise when the flow rate of tertiary air is low. Damage due to burning or deformation is apt to occur when the temperature of the member rises higher than sustainable tolerances. Therefore a material of high heat resistance for the movable wall 2 should be utilized.

A method of adjusting a burner at the time of trial operation is discussed below. Immediately after the burner is installed on the boiler, an intended flow rate may not be achieved. This may be caused by manufacturing errors of the burner, asymmetry of upstream ducts, setting errors of the resistors, the dampers installed on the burner, etc. Further, in some cases, it is necessary to set a flow rate of air according to deviation of fuel for each burner. Therefore, by adjusting the air resistor 7 of the tertiary nozzle 9, the tertiary damper 35, the secondary damper 34 and the movable wall 2, combustion conditions suitable for reduction of NO<sub>x</sub>, CO, unburned fuel, soot, corrosion, and the metal temperature of the burner part are achieved. Examples of the adjusting method are described below.

**Example 1**

In the case where flame stability is poor, the following operations are conducted to improve the flame stability:

(1.1) In the case where the momentum of tertiary air is low:

5           The movable wall 2 is moved to a near side or to the left side in Fig. 1 to  
make the flow path area of the tertiary nozzle narrow. Under this condition, the  
pressure loss of the tertiary air increases so that a flow rate of the tertiary air  
decreases and a flow rate of the secondary air increases. In order not to change  
these flow rates, the air resistor 7 or the tertiary damper 35 of the tertiary nozzle 9  
10 is opened, or, the secondary damper 34 is closed to stop the secondary air flow.  
By increasing the momentum of the tertiary air, a flow recirculation region  
downstream of the stabilizer 10 enlarges and flame stability is increased.

(1.2) In the case where the momentum of secondary air is low:

15           The flow rate of secondary air is increased, by closing the air resistor 7 of  
the tertiary nozzle 9 to increase air swirling or moving the movable wall 2 to the  
near side to make the flow speed of the tertiary air high. The increase in flow rate  
and momentum of the secondary air makes the flow recirculation region  
downstream of the stabilizer 10 larger and raises the flame stability. However,  
when the secondary air increases too much, in some cases the flow recirculation is  
20 decreased. An optimum flow rate exists for the secondary air.

In Fig. 2, by having moved the movable wall 2, the minimum flow path area between the stabilizer 10 and the guide sleeve 3 has been widened. Therefore, there is the possibility that the jetting flow speed of the secondary air decreases. When the flow speed is low, a cooling effect of the stabilizer 10 decreases, so that it is beneficial  
5 for the stabilizer 10 to extend in the moving direction of the movable wall 2 so that it does not change the minimum flow path area even if the movable wall 2 is moved.

### Example 2

In the case where the concentration of NO<sub>x</sub> is high, the following method is performed:

10 (2.1) Increasing the stability of the flame decreases the concentration of NO<sub>x</sub>.

(2.2) In the case where the flame is sufficiently stabilized, and it is desired to further reduce the concentration of NO<sub>x</sub>, it is effective to delay mixing of the air. In order to delay the mixing of air, it is effective to decrease the flow rate of the secondary air and increase the flow rate of the tertiary air. To perform this, the secondary  
15 damper 34 is closed, or the movable wall 2 is moved so that the tertiary air outlet is opened. Further, it can be achieved by increasing the momentum of tertiary air. The delay of mixing of air can also be attained by closing the air resistor 7 of the tertiary nozzle 9 and increasing swirling of tertiary air. In this case, it is necessary to close the secondary damper 34 so that the flow rate of the tertiary air does not decrease.

**Example 3**

In the case where unburned fuel is significant, the following method is performed:

(3.1) There is a possibility that unburned fuel could significantly increase without conducting flame stability. Therefore, it is effective to take a setting similar to  
5 the setting for improvement on flame stability.

(3.2) In the case where the flame is sufficiently stabilized, it is desired to further reduce the unburned fuel, it is effective to increase secondary air. In this case, there is a possibility that the momentum of tertiary air decreases and the flame stability decreases when the secondary damper 34 is opened. Therefore, it is effective to increase the flow  
10 speed of tertiary air by moving the movable wall 2 to the near side or to make the swirling stronger by closing the air resistor 7 of the tertiary nozzle 9.

(3.3) For reduction of unburned fuel, it is effective to raise the burner air ratio. The flow rate of air increases by raising the burner air ratio, mixing of air and fuel improves, and the concentration of NOx increases. In order to reduce the concentration  
15 of NOx, the method described in the example 2 can be applied.

**Example 4**

To reduce corrosion, adjustment is conducted by the following method:

(4.1) Low air flow around the wall makes the concentration of gas and corrosion speed higher. To supply air around the wall, it is effective to increase the flow  
20 rate of tertiary air. Therefore, it is effective to open the movable wall 2 to make the flow path area of the tertiary nozzle 9 wider as to increase the tertiary air flow rate. Further, increasing air circulation around the wall by increasing the momentum of tertiary air is possible by closing the secondary damper 34.

(4.2) Since it is also possible to decrease the flame stability and to decrease reducing gas, it is possible to perform an operation reverse to that in the example 1.

(4.3) The reducing gas and corrosion can be reduced, also by increasing air quantity to the burner close to the wall that is apt to corrode. Therefore, it is effective to  
5 adjust air distribution by adjusting the movable wall 2, the resistor, and the damper for each burner to increase the air quantity.

### **Example 5**

In the case where it is desired to greatly change the type of fuel used, adjustment is conducted by the following method:

10 (5.1) When the type of fuel is greatly changed, or pulverization and an amount of volatile matters in the fuel changes, it is better to change the damper opening, the position of the movable wall 2 and the setting of the air resistor 7 in order to keep the flame stabilized and reduce NO<sub>x</sub>. In the case where fuel is changed from a fuel of high combustibility to a fuel of low combustibility, there is a possibility that the flame stability  
15 decreases. In this case, it is better to make adjustments to improve the flame stability.

(5.2) Low fuel combustibility can result in an increased concentration of NO<sub>x</sub> therefore requiring adjustments to reduce NO<sub>x</sub>.

### **Example 6**

In the case where ash is deposited in the fuel, the following method can be  
20 performed:

(6.1) In the case where the flame stability is high and ashes in the fuel melt and deposit around the burner, the movable wall 2 is moved forward (to the opposite side to the near side) to increase the outlet cross-sectional area for tertiary air, decrease the flow

speed of the tertiary air and reduce the flame stability. By operating in this way, the combustion temperature decreases, so that deposition of ashes is reduced. At the same time, secondary air also increases, the temperature around the stabilizer 10 decreases and the ashes can be prevented from melting.

- 5           (6.2) In the case where molten ash deposits on the wall of boiler, it is beneficial to supply air around the wall. Therefore, it is better to operate so that air is supplied around the wall by moving the movable wall 2 to the near side to change the jetting direction of tertiary air outwardly.

#### **Example 7**

- 10           In the case where the temperature of the stabilizer 10 is high, the following operation is conducted:

15           When the temperature of the stabilizer 10 is high, it is effective to increase the flow speed of secondary air. In order to increase the flow rate of secondary air, the tertiary damper 35 or the air resistor 7 is closed. In this case, there is such a possibility that the momentum of tertiary air decreases and the stabilization of flame decreases. Therefore, the movable wall 2 is moved to the near side instead of closing the tertiary damper 35 and the air resistor 7 keeping both the flame stabilized and reducing the temperature.

#### **Example 8**

- 20           Decreasing the minimum load of the boiler is conducted as follows:

Boiler load is not always 100% but it is changed according to power demands. If it can be run at a very low load, the operation efficiency of the boiler increases. Usually, burners are designed so that the performance is optimal at 100% load. When the load is low, respective flow rates of fuel and air entering the furnace from the burner decrease,

so that there is a possibility that the air momentum becomes unbalanced and the flame stability decreases. For example, when the momentum of tertiary air is low, it is effective to increase the momentum by moving the movable wall 2 to the near side. This operation is the same as the method of increasing the stability of the flame as described in the  
5 example 1. However, when the stability of the flame is increased under the low load operation, in some cases, the combustibility becomes low at a high load. It is better to set in such a range of operation such that the combustibility does not become low even at a high load.

## EMBODIMENT 2

10 Fig. 5 is a sectional view of another embodiment of the burner according to the present invention. The present embodiment 2 differs from the embodiment 1 in that motor boxes 6 are provided and the movement of the movable wall 2 is electrically driven. Further, in Fig. 5, although the motor boxes 6 are installed inside the wind box, it is possible to install them outside the wind box. Further, an air resistor 15 is provided in  
15 the secondary nozzle 8. It is possible to control the flow rate and swirling force by combining the air resistor 15 and the secondary damper 34.

A benefit of driving the movable wall 2 by the motor 6 is that the movable wall 2 is controlled according to the algorithm of combustion adjustment described in the embodiment 1, and an optimum combustion condition can be maintained. As explained  
20 below it is possible to provide a suitable operation condition by changing flow rate conditions.

In some cases, the burner is out of service without fuel being supplied. Under such a condition, there is a possibility that the out of service burner being heated by radiant heat from other burners and the temperatures of the guide sleeve 3, the  
25 stabilizer 10, etc. rise. To prevent this phenomenon, it is necessary to supply air to the

burner even when it is out of service. When a flow rate of air to be supplied to the out of service burner is large, an air adjustment quantity is small. Therefore, it is necessary to reduce the flow rate of air to be supplied to the out of service burner. When the flow rate is decreased under the condition that the movable wall 2 is fixed, the flow speeds of tertiary air and secondary air decrease, and it is impossible to sufficiently cool the guide sleeve 3 and the stabilizer 10.

In the present invention, the burner is adjusted to the condition as shown in Fig. 6 when the burner is out of service. That is, the movable wall 2 is moved to the rear side, the jet portion area of tertiary air is almost zero. Since the flow speed at the end of the guide sleeve 3 is high, the guide sleeve 3 can be cooled even with a small quantity of tertiary air. Further, by increasing the flow rate of secondary air, it is possible to increase the flow speed of secondary air and effectively cool the stabilizer 10. Since secondary air is lower in flow rate than tertiary air, it is possible to decrease the whole air flow rate even if the secondary air is increased.

In the above-described embodiments, the tertiary nozzle is provided with the air resistor 7. However, it is possible to form it without provision of such an air resistor 7. The air resistor 7 is for controlling a combustion field by swirling the tertiary air, because in the present invention the same effect can be attained by moving the movable wall 2 forward and backward in the burner axis direction. Further, the air resistor 15 of the secondary nozzle is not essential. In this case, the secondary damper 34 is necessary because any method of adjusting a flow rate of secondary air is not available.

A construction of a controller used for the embodiment 2 is shown in Fig. 7. The controller 101 receives signals from measuring instrument and sends signals for moving movable parts of the burner 102. For example, signals for driving a movable wall moving motor 111, an air resistor 7, driving motor 112, a tertiary damper driving motor 113, a secondary damper driving motor 114, an air resistor 15, driving motor 115,

etc. are provided. The controller 101 has software incorporated for realizing the method described in embodiment 1. The measuring instrument installed in the burner includes a flame detector 107, a temperature detector or thermometer 108 for burner metal, a pressure gauge 109 for combustion air, a flow meter 110 for burner air, etc. The measuring instrument mounted on a boiler 116 includes a temperature detector or thermometer 103 for steam, an ash deposition sensor 104, an NOx sensor 105, an unburned fuel sensor 106 for measuring CO concentration and unburned components of solids, etc. For example, in order to examine the stability of the flame, the flame detector 107 is used. A flame detector that can detect luminous intensity can be utilized. It is possible to evaluate the stability of the flame by the luminous intensity and change in operation conditions. The NOx sensor 105 can be installed at a downstream side of the boiler 116, at which the reaction has terminated. It is beneficial to install a plurality of the NOx sensors and adjust the movable wall 2, the resistor and the damper for each burner while examining concentration distribution of NOx. The unburned fuel sensor 105 can be installed at a downstream side of the boiler 116 as installation of the NOx sensor.

### **EMBODIMENT 3**

Figs. 8, 9, 10 and 11 are sectional views showing another embodiment of the burner according to the present invention. In an example of Fig. 8, holes 16, 32 for tertiary air bypass are formed in the fixed wall 1 and the movable wall 2 of the partition wall partitioning the secondary nozzle 8 and the tertiary nozzle 9, respectively, and tertiary air flows through those holes into the secondary nozzle 8 as shown by an arrow 17, bypassing the tertiary nozzle 9. In this case, the tertiary air flows into the secondary nozzle under the condition that the movable wall 2 is moved to the near side and fuel supply is out of service as shown in Fig. 8. With this construction, even in the case where the movable wall 2 has been moved to the near side and the secondary air has been stopped, air is automatically supplied into the secondary nozzle 8 and it is possible

to prevent the temperature of the stabilizer 10 from rising. It is possible to make the flow rate larger by providing not only one hole 16, 32 for tertiary air bypass but a plurality of the holes 16, 32.

5 Fig. 9 shows an example in which the tertiary air bypasses the tertiary nozzle 9 and is supplied to the primary nozzle. In this example, holes are formed in the tubular wall of the primary nozzle 4, and bypass pipes 18 connect between the holes provided in the fixed wall 1 and the holes formed in the primary nozzle. In the case where the burner is out of service, little air is supplied to the primary nozzle, and the inner side of the stabilizer cannot be cooled.

10 In the case where the concentration of oxygen in the air carrying fuel is low, it is beneficial to decrease the tertiary air jet sectional area of the tertiary nozzle 9 by moving the movable wall 2 to the near side, to increase the flow rate of bypass air. When lignite is used, the fuel easily ignites and is carried with flue gas. When the burner load is high, even if the oxygen concentration of primary air is low, stable combustion is possible  
15 because the gas temperature is high inside the combustion apparatus, for example, the boiler. However, when the load decreases, the gas temperature inside the combustion apparatus decreases and unburned fuel increases and is carried with flue gas unless the oxygen concentration of the primary air increases. In such a low load case, tertiary air flows into the primary nozzle 4 to enable stable combustion. Although a construction  
20 such that tertiary air always bypasses and flows into the primary nozzle 4 is also considered, combustion is promoted when the load is high and the possibility of an explosion and ash deposit becomes high, therefore as the load decreases, the air flow should be increased.

25 Fig. 10 shows an example in which bypassed secondary air is supplied to the primary nozzle. In this example, holes are formed in the tube wall of the primary nozzle 4, and air is supplied from the secondary nozzle to the primary nozzle through

bypass pipes 18. In the case where the burner is out of service, the movable wall 2 is moved to the near side and the air resistor 15 is closed whereby secondary air is supplied along the wall of the primary nozzle.

Further, in a similar manner to the example of Fig. 9, when the oxygen  
5 concentration of the primary air is low, it is possible to effect stable combustion by increasing the flow rate of bypass air. When it is desired to decrease the combustion speed, the pressure at the intake port of bypass air is lowered. For example, the movable wall 2 is moved to widen the jet area of tertiary air, or open the air resistor 15.

Fig. 11 shows an example where bypassed tertiary air is used for cooling a  
10 pulverized coal concentrator 20 provided inside the primary nozzle 4. The pulverized coal concentrator 20 is formed so as to gradually narrow the flow path of the primary nozzle toward a downstream side and gradually widen the flow path toward a further downstream side as shown in Fig. 11, and serves to increase the pulverized coal concentration on the wall side of the primary nozzle. In the out of service condition, the  
15 flow rate of primary air is small, so that it is difficult to cool the pulverized coal concentrator 20. Therefore, a construction is required such that tertiary air flows to the pulverized coal concentrator 20 under the out of service condition. In Fig. 11, bypass tubes 19 are provided, and each of the bypass tubes 19 connects the hole of the fixed wall 1 and the hole of the primary nozzle 4 and is extended to the pulverized coal  
20 concentrator 20. The air used for cooling the pulverized coal concentrator 20 is jetted into the furnace from the end of the pulverized coal concentrator 20.

In some instances, the pulverized coal burner is provided with an oil burner formed so as to spray oil 21 for assisting combustion from an atomizer 31 as shown in Fig. 11. By moving the movable wall 2, it is possible to change a ratio of the flow rate of  
25 air flowing in a central portion of the burner and the flow rate of air flowing outside thereof. Thereby it is possible to control NO<sub>x</sub> and soot.

**EMBODIMENT 4**

Fig. 12 is a sectional view of a burner of another embodiment of the present invention. In this embodiment, the motor boxes 6 are mounted out of the wall 28 of the wind box. The secondary air and tertiary air are at a temperature of 300°C or more, and in some cases it includes ash. When the motor boxes 6 are mounted in such a location, they may become inoperable and difficult to repair. Further, in the present embodiment, the fixed wall 1 is shorter than that in Fig. 5. With this construction, even if a portion close to the end of the movable wall 2 is deformed by heat, a portion contacting with the fixed wall 1 is disposed in a deeper bowel of the burner, reducing the possibility that movement is obstructed.

Further, a stopper 2 on movable wall 2 is provided to prevent excessive forward movement due to sensor failure, etc. Although not shown in Fig. 12, in a similar manner, a stopper can be provided to limit movement of movable wall 2 to the near side.

Further, in Fig. 12, the cooling efficiency is raised by providing cooling fins 22 on the movable wall 2 and the guide sleeve 3. The cooling fins 22 also serve to increase the strength.

In Fig. 12, temperature detectors of thermostats 29 are mounted on the guide sleeve 3 and the stabilizer 10, respectively. The position of the movable wall 2 can be controlled, based on values of the thermostats. In this case, when the temperature of the end of the guide sleeve is higher than a limit value, the flow speed of the tertiary air is slow, such that the operation that the flow rate of the secondary air is reduced and the flow speed of the tertiary air is raised. When the temperature of the stabilizer is higher than a limit value, the operation condition of the example 7 of the embodiment 1 can be taken. In the case where the temperatures of the guide sleeve and the stabilizer are higher than the limit values, respectively, the quantity of the whole air can be increased.

Figs. 13, 14 and 15 are a sectional view taken along XIII-XIII, XIV-XIV and XV-XV of Fig. 12, respectively and show various configuration examples. The configurations shown in Figs. 13 to 15 can be used for not only the burner of Fig. 12, but the burner of Fig. 1. Fig. 13 shows an example where four movement control rods 5 are moved by gears 26 and power transmission shafts 27 driven by one motor 25. This enables reducing the number of motors and allows the displacements of the movement control rods 5 to be equal. Fig. 14 is an example where the motor 25 shown in Fig. 13 is not utilized and the movement control rods 5 are moved by rotation of a manual handle 27. Fig. 15 shows an example where four motors 25 are used and even if one of the motors 25 is out of order and the rods 5 can be driven by the other motors.

#### **EMBODIMENT 5**

Figs. 16, 17 and 18 are sectional views of another embodiment of the burner according to the present invention. Fig. 17 is a sectional view taken along XVII-XVII of Fig. 16, and Fig. 18 is a sectional view taken along XVIII-XVIII of Fig. 16. A difference from Fig. 1 is that the burner is not made of triple tubes, a primary nozzle 4 and a secondary nozzle 8 each are made of a square tube, and a tertiary nozzle 9 is separated into an upper portion and a lower portion. In this case, it is possible to make an optimum operational condition by moving a movable wall 2 having a guide sleeve 3 forward and backward in a similar manner to the embodiment 1. In the present embodiment, since the movable wall 2 is separated into an upper portion and a lower portion, it is possible that they are not moved forward and backward in an interlocked manner. Therefore, as shown in Fig. 17, it is possible to connect the movable walls 2 by connecting plates 36. In the present embodiment, as shown in Fig. 18, handles 33 are mounted at four positions, and the movable wall 2 is moved manually, however, it can be moved by a motor or motors as in the embodiment 2.

**EMBODIMENT 6**

An example of alternate uses of the burner according to the present invention will be explained. In Fig. 19, the x-axis defines the burner load. Air for cooling flows evenly at a burner load of 0%, and in this case, in order to cool the stabilizer 10, the movable wall 2 is moved so that the outlet of tertiary air becomes a condition near to full closing. For the coal firing burner, since combustion is assisted by oil at the time of a low load, oil and coal are supplied. When it reaches a state at which combustion can be performed with only coal, the flow rate of oil is reduced to zero. When the oil is burned, it is better to increase a flow rate of air at a position near to a central portion to which oil is supplied, so that the movable wall 2 is moved to the near side so that the outlet of tertiary air is nearly closed. A flow rate of supplied air is increased as a flow rate of coal increases. Since stable combustion can be performed even if the momentum of tertiary air is low, the movable wall 2 is moved to the near side to increase the size of the tertiary air outlet to nearly fully open.

The present invention makes it possible to cool the burner while reducing NOx by controlling the combustion condition optimum. The possibility of utility of the burner according to the present invention is large to make thermal failure of the burner less.

The embodiments of the invention in which an exclusive property or privilege is claimed are defined as follows:

1. A fuel combustion burner comprising a primary nozzle for supplying fuel and primary air, a secondary nozzle for supplying secondary air, provided outside said primary nozzle, and a tertiary nozzle for supplying tertiary air, provided outside said secondary nozzle so as to contact with the outside of said secondary nozzle, said secondary nozzle and said tertiary nozzle being partitioned by a partition wall, wherein:  
said primary nozzle has a stabilizer provided at an end thereof, said partition wall has thereon a flow path change member for changing a flow of tertiary air from a flow along an axis of the burner to an outward flow which jets the tertiary air, and said partition wall is movable in the burner axial direction allowing to a substantially closed condition of an outlet of said tertiary nozzle.
2. The fuel combustion burner according to claim 1, wherein said partition wall has a guide sleeve as said flow path change member at an end thereof.
3. The fuel combustion burner according to claim 1, wherein said primary nozzle is a nozzle constituted so as to pneumatically transfer fuel with the primary air.
4. The fuel combustion burner according to claim 1, wherein said partition wall is provided thereon with a bypass mechanism for allowing a part of the tertiary air to bypass said tertiary nozzle into one of said primary nozzle and said secondary nozzle when said partition wall is moved to a predetermined position.
5. The fuel combustion burner according to claim 1, wherein said partition wall is composed of a fixed wall and a movable wall, said flow path change member is provided on said movable wall.
6. The fuel combustion burner according to claim 5, wherein holes for allowing tertiary air to bypass are formed in said fixed wall and said movable wall, respectively.

7. The fuel combustion burner according to claim 6, wherein said primary nozzle has a hole formed in an outer wall thereof, and a bypass pipe is provided between said hole formed in said fixed wall and said hole formed in said outer wall of said primary nozzle so that tertiary air passes through said holes formed in said fixed wall and said  
5 movable wall flows into said primary nozzle.
8. The fuel combustion burner according to claim 7, wherein said bypass pipe has a jet outlet formed so that the tertiary air flowed into said primary nozzle flows along an inner wall of said primary nozzle.
9. The fuel combustion burner according to claim 7, wherein said primary nozzle  
10 is a nozzle for supplying pulverized coal, said primary nozzle has a pulverized coal concentrator provided inside for narrowing a cross-sectional area of a flow path and concentrating the pulverized coal, and said bypass pipe is extended to said pulverized coal concentrator so that the tertiary air flowed into said primary nozzle flows along the surface of said pulverized coal concentrator.
- 15 10. The fuel combustion burner according to claim 1, wherein fins for cooling said flow path change member and said partition wall in the vicinity of said flow path change member are provided on said flow path change member and said partition wall in the vicinity of said flow path change member.
- 20 11. The fuel combustion burner according to claim 5, wherein said partition wall is constituted so that said movable wall slides on said fixed wall, and guide rollers for guiding said movable wall are provided on said fixed wall.
12. The fuel combustion burner according to claim 5, wherein a stopper for stopping said movable wall is provided on at least one of said fixed wall and said movable wall.
- 25 13. The fuel combustion burner according to claim 1, wherein a wind box for supplying secondary air and tertiary air is provided, and a mechanism for moving said partition wall is arranged outside said wind box.

14. A fuel combustion method by a burner comprising a primary nozzle for supplying fuel and primary air, a secondary nozzle for supplying secondary air, provided outside said primary nozzle, a tertiary nozzle for supplying tertiary air, provided outside said secondary nozzle so as to contact with the outside of said secondary nozzle, a stabilizer provided at an end of said primary nozzle, said secondary nozzle and said tertiary nozzle being partitioned by a partition wall, and a flow path change member provided on said partition wall for changing a flow of the tertiary air from a flow along the burner axis to an outward flow, said partition wall being constituted to be movable in the burner axis direction, wherein:
- 10           said partition wall is moved depending on one or more of a load change, a temperature at a burner axis end portion, properties of the fuel, a concentration of nitrogen oxides, a concentration of unburned fuel, and a fuel supply stoppage, said partition wall allowing adjustment of an outlet of said tertiary nozzle to a substantially closed condition.
- 15    15. The fuel combustion method according to claim 14, wherein at the time of stoppage of fuel supply to said burner, said partition wall is moved so that a cross-sectional area of a tertiary air jetting outlet of said tertiary nozzle becomes small, thereby increasing a flow rate of the secondary air from said secondary air nozzle.
- 20    16. The fuel combustion method according to claim 14, wherein said method further comprises step of moving said partition wall so that the cross-sectional area for jetting tertiary air of said tertiary nozzle decreases when a temperature of said flow path change member becomes higher than a set temperature during combustion of fuel by the burner, and increasing a flow speed of the tertiary air.
- 25    17. The fuel combustion method according to claim 14, wherein a part of the tertiary air supplied to said tertiary nozzle is caused to bypass a flow path of said tertiary nozzle into said secondary nozzle during stoppage of fuel supply to said burner.

18. The fuel combustion method according to claim 14, wherein a part of the tertiary air supplied to said tertiary nozzle is caused to bypass a flow path of said tertiary nozzle to flow along an inner wall of said primary nozzle during stoppage of fuel supply to said burner.

- 5 19. A method of retrofitting a boiler having a burner which is provided on a furnace wall and comprises a primary nozzle for supplying fuel and primary air, a tubular secondary nozzle for supplying secondary air, provided outside said primary nozzle so as to enclose said primary nozzle, a tubular tertiary nozzle for supplying tertiary air, provided outside said secondary nozzle, a stabilizer provided at an end of  
10 said primary nozzle, a tubular partition wall fixed between said secondary nozzle and said tertiary nozzle, wherein said method comprises:
- removing at least an end portion of said partition wall; and
  - providing, around the position of the removed portion of said partition wall, a tubular partition wall with a flow path change member for changing a flow of tertiary  
15 air from a flow along the burner axis to an outward flow so as to be movable in the burner axial direction, said tubular partition wall allowing adjustment of an outlet of said tubular tertiary nozzle to a substantially closed condition.

FIG. 1

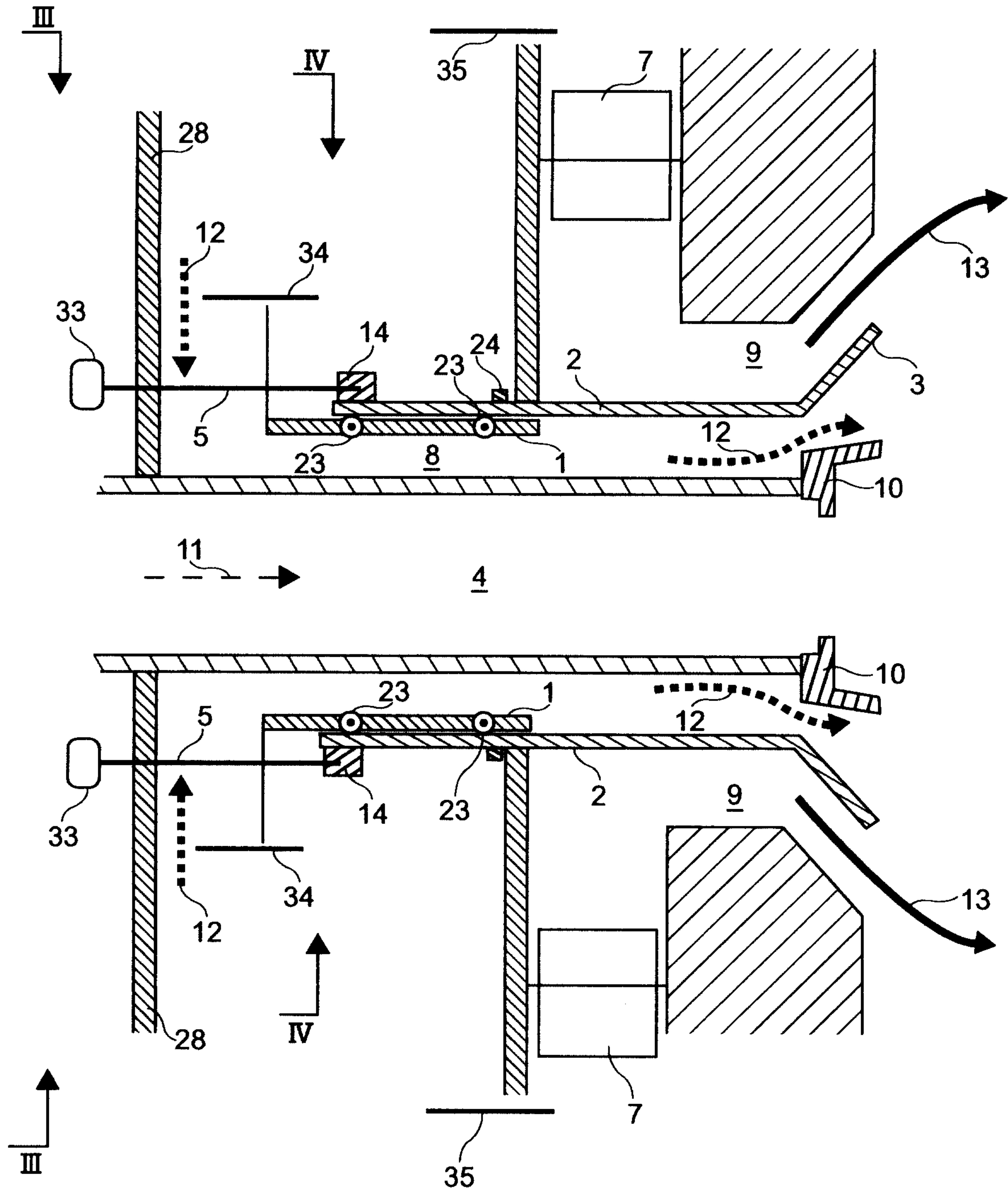
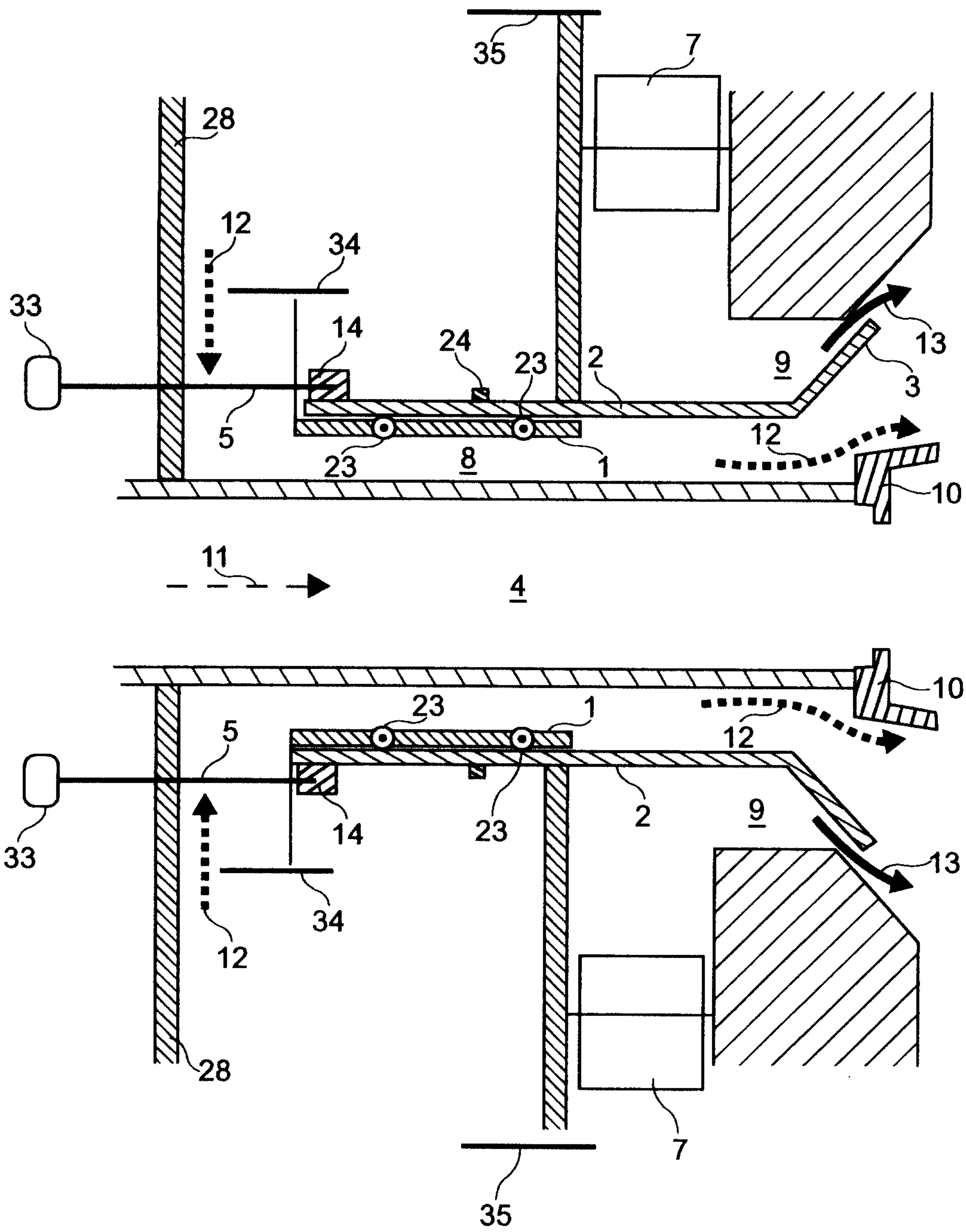
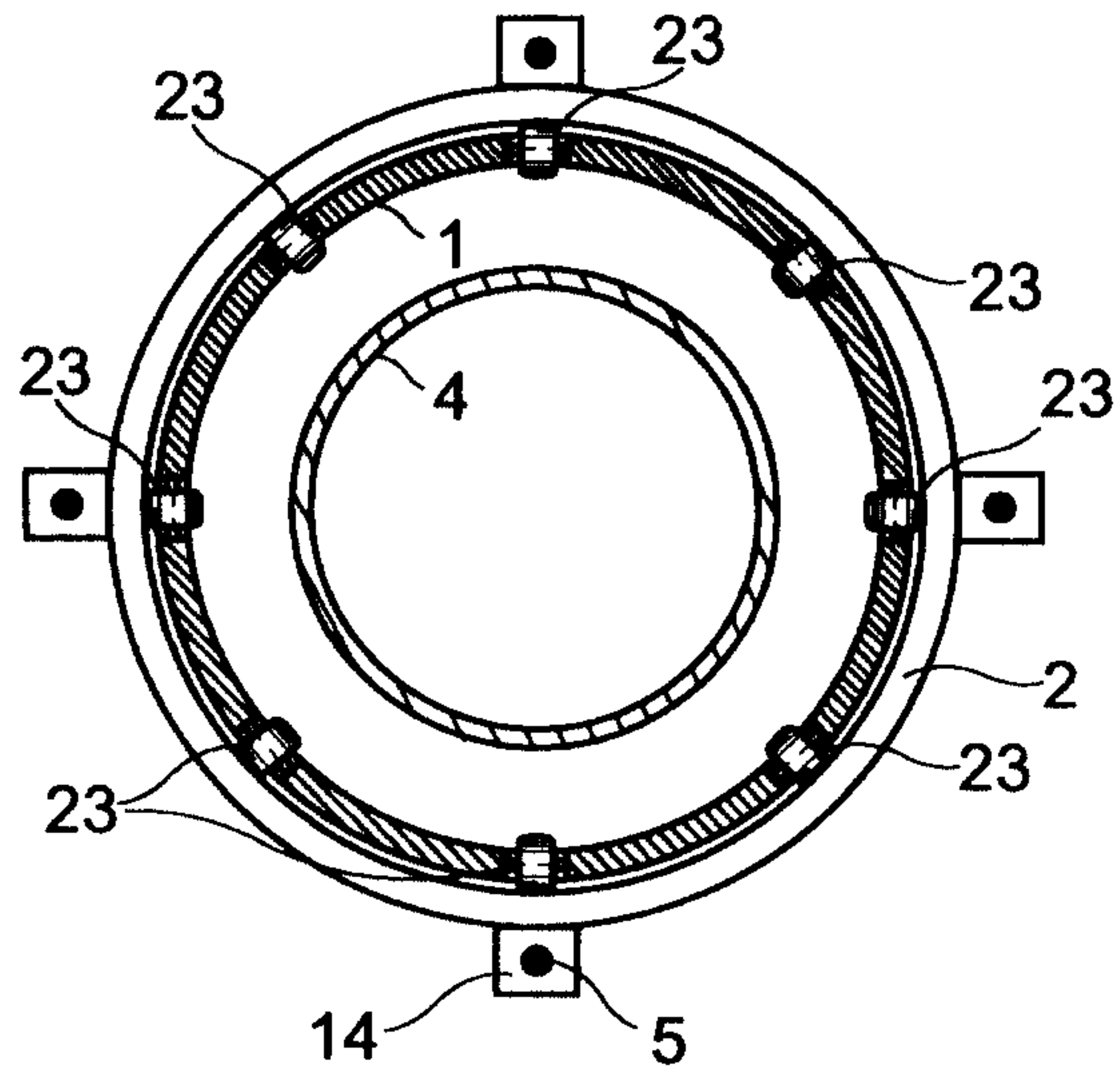

FIG. 2



**FIG. 3**



**FIG. 4**

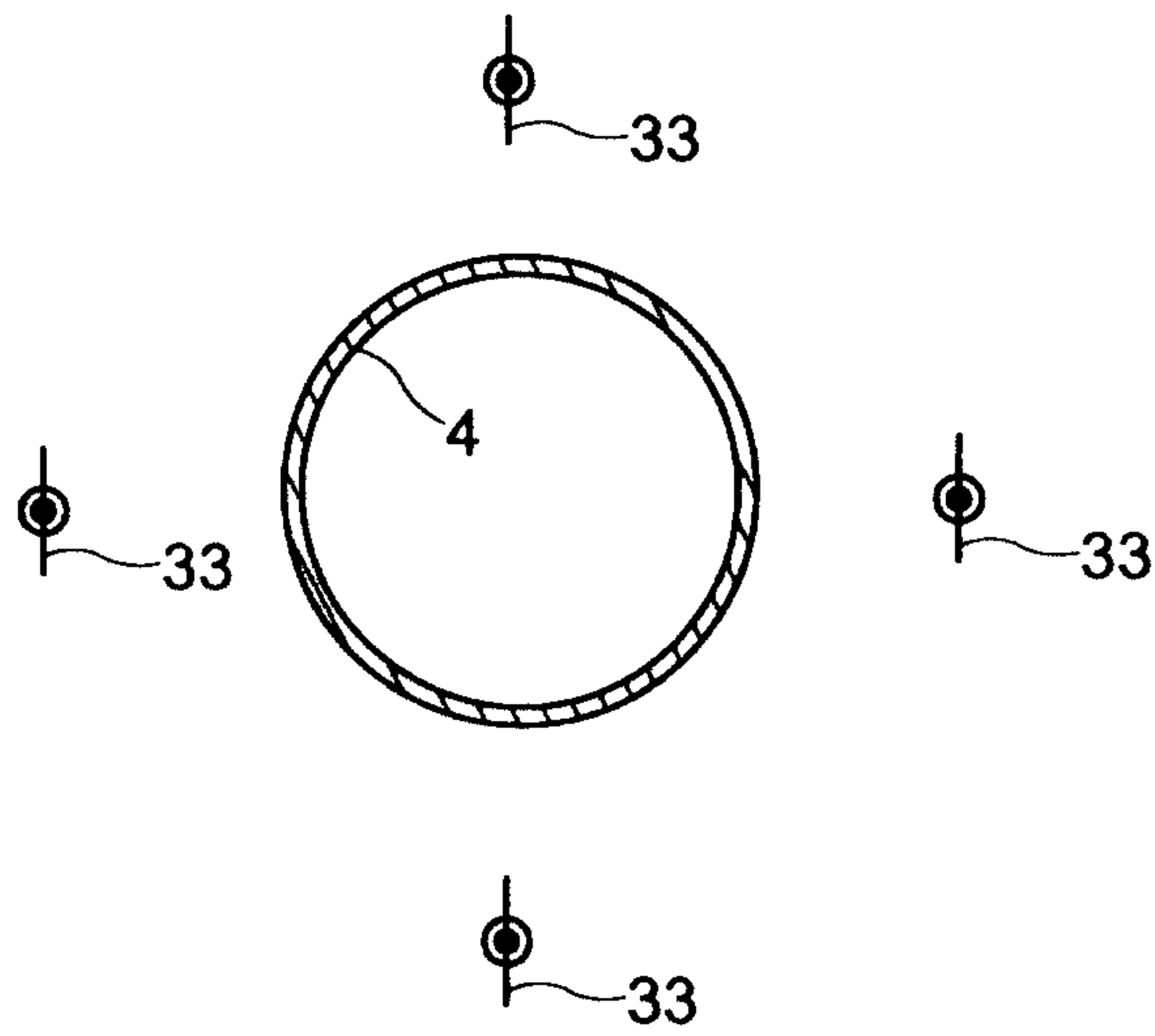

FIG. 5

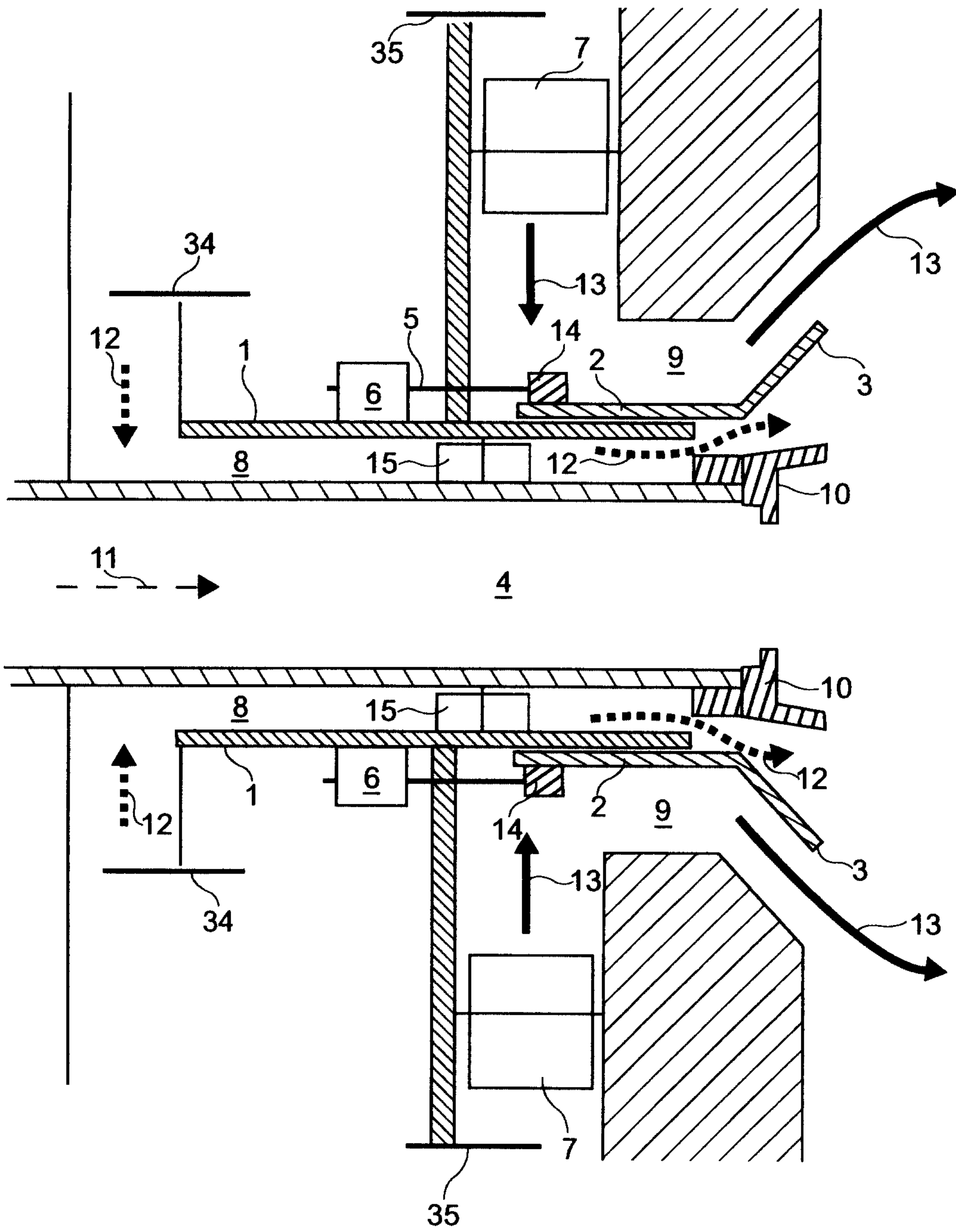
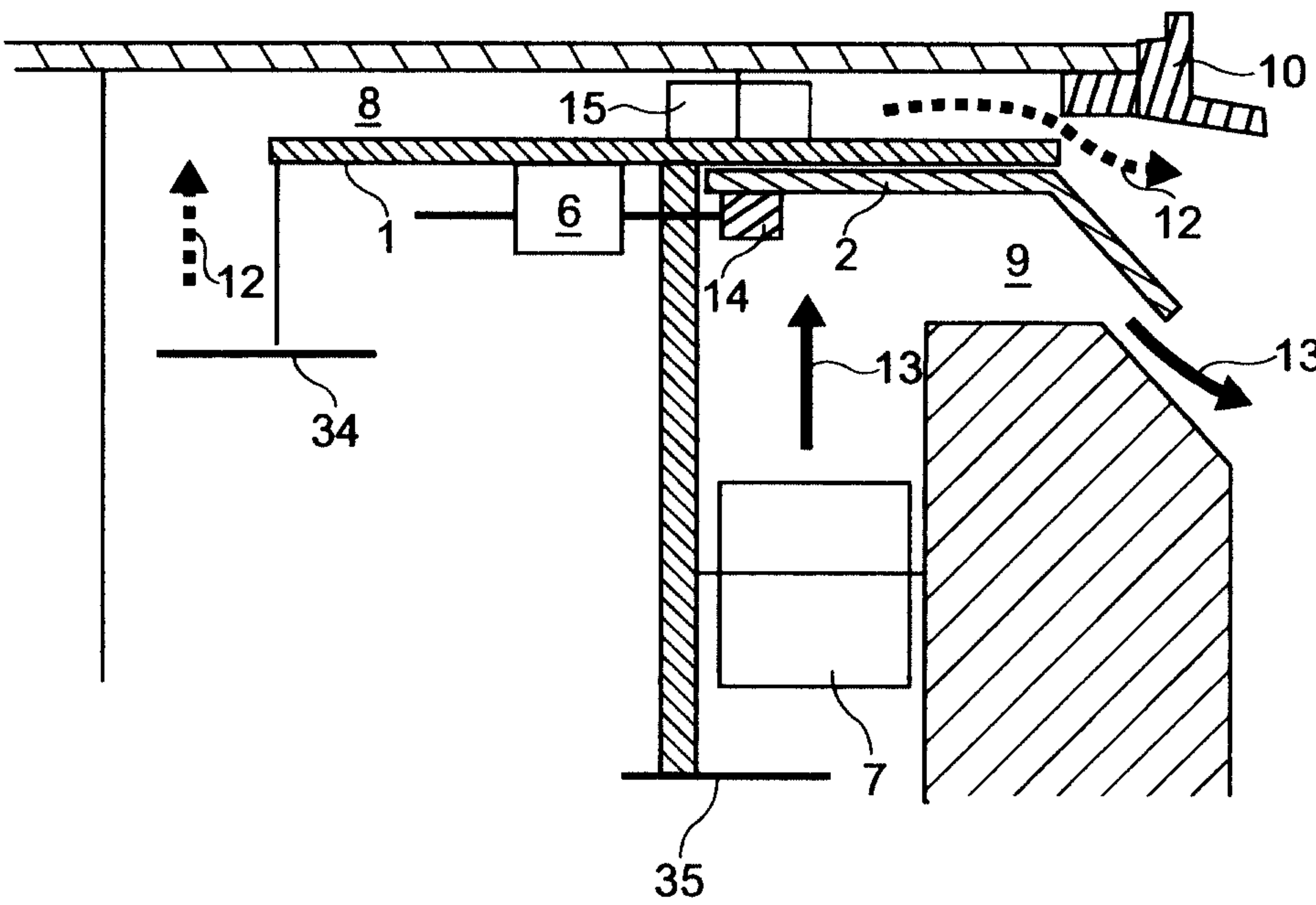
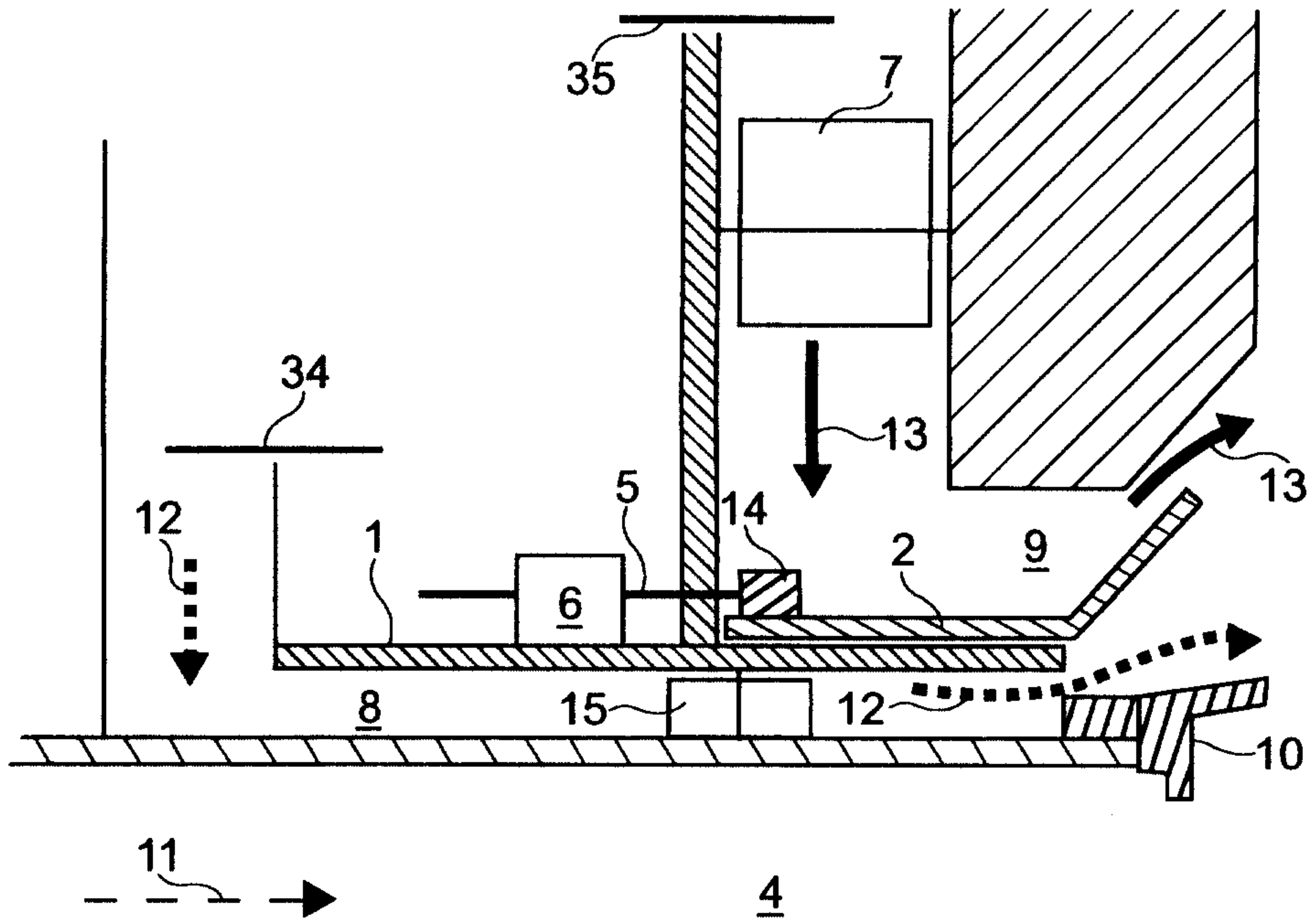

FIG. 6



**FIG. 7**

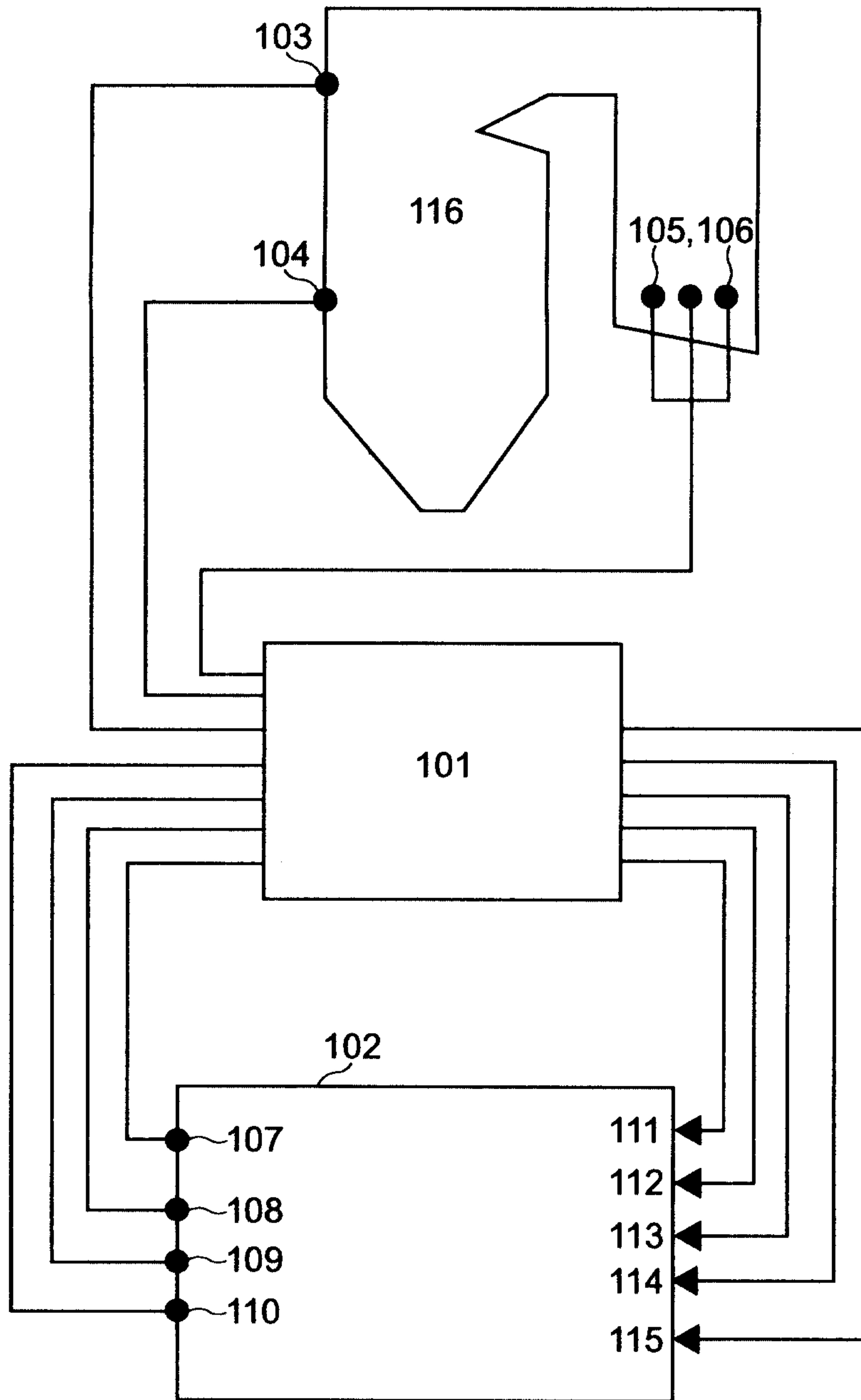



FIG. 9

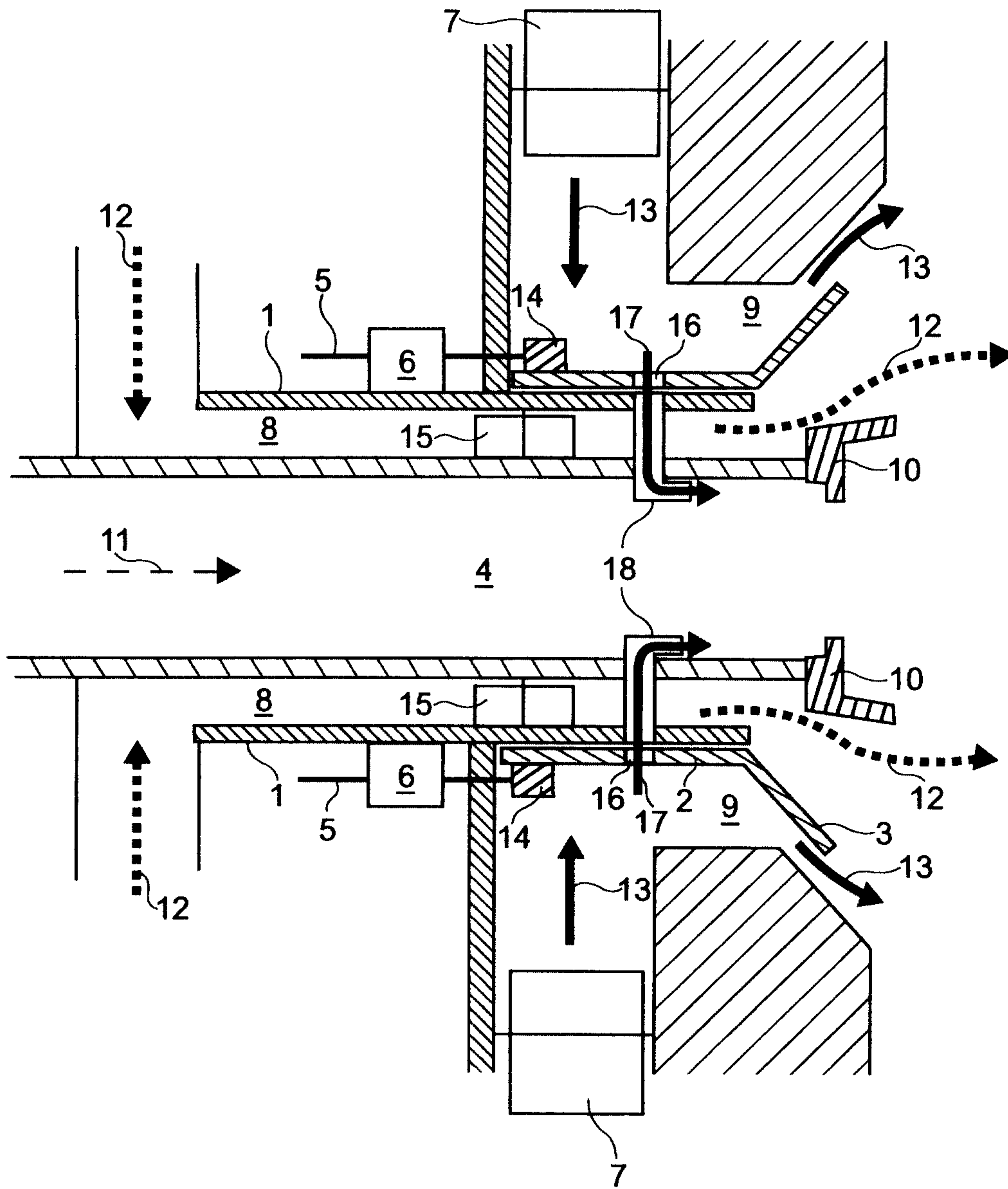



FIG. 11

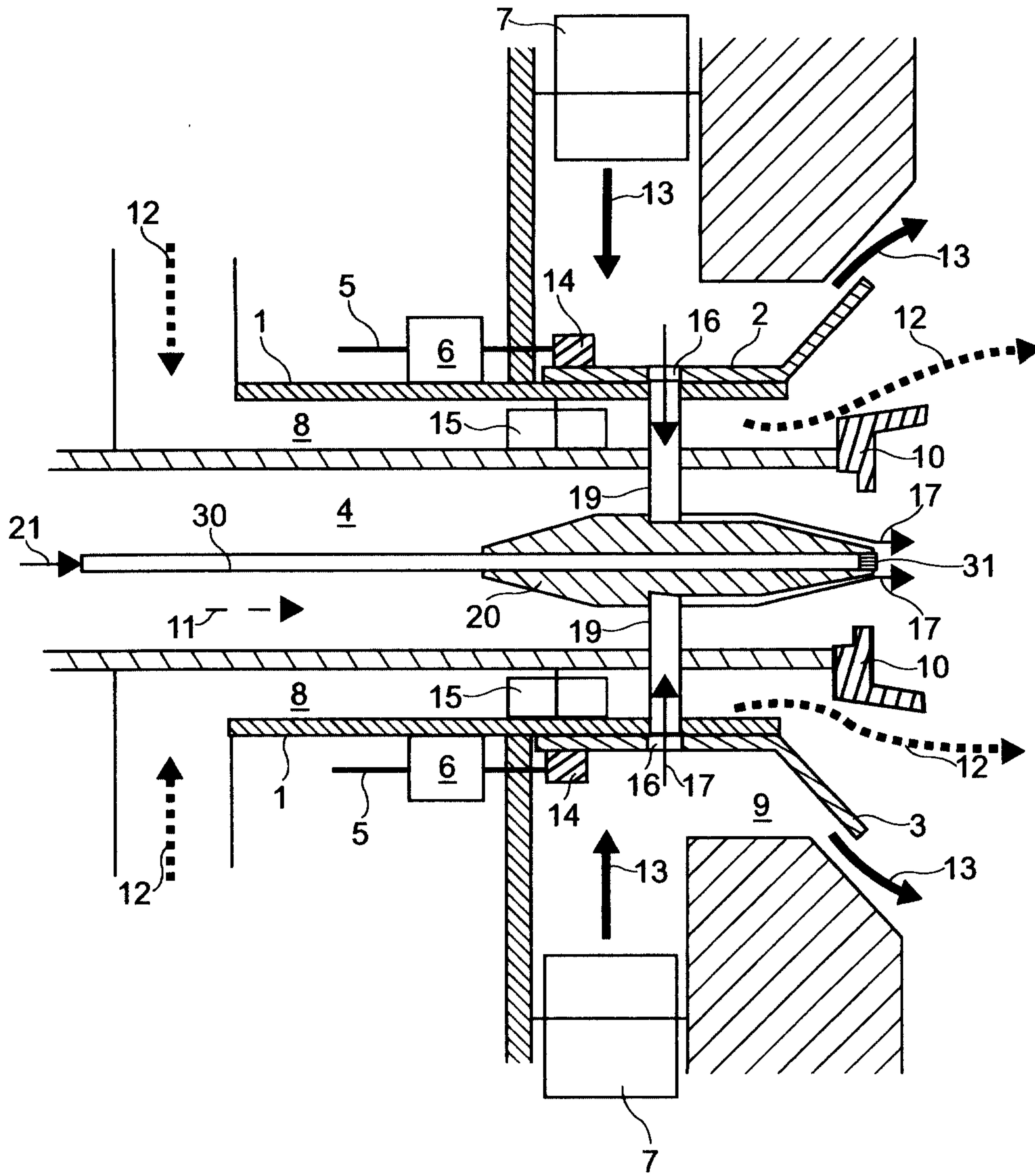
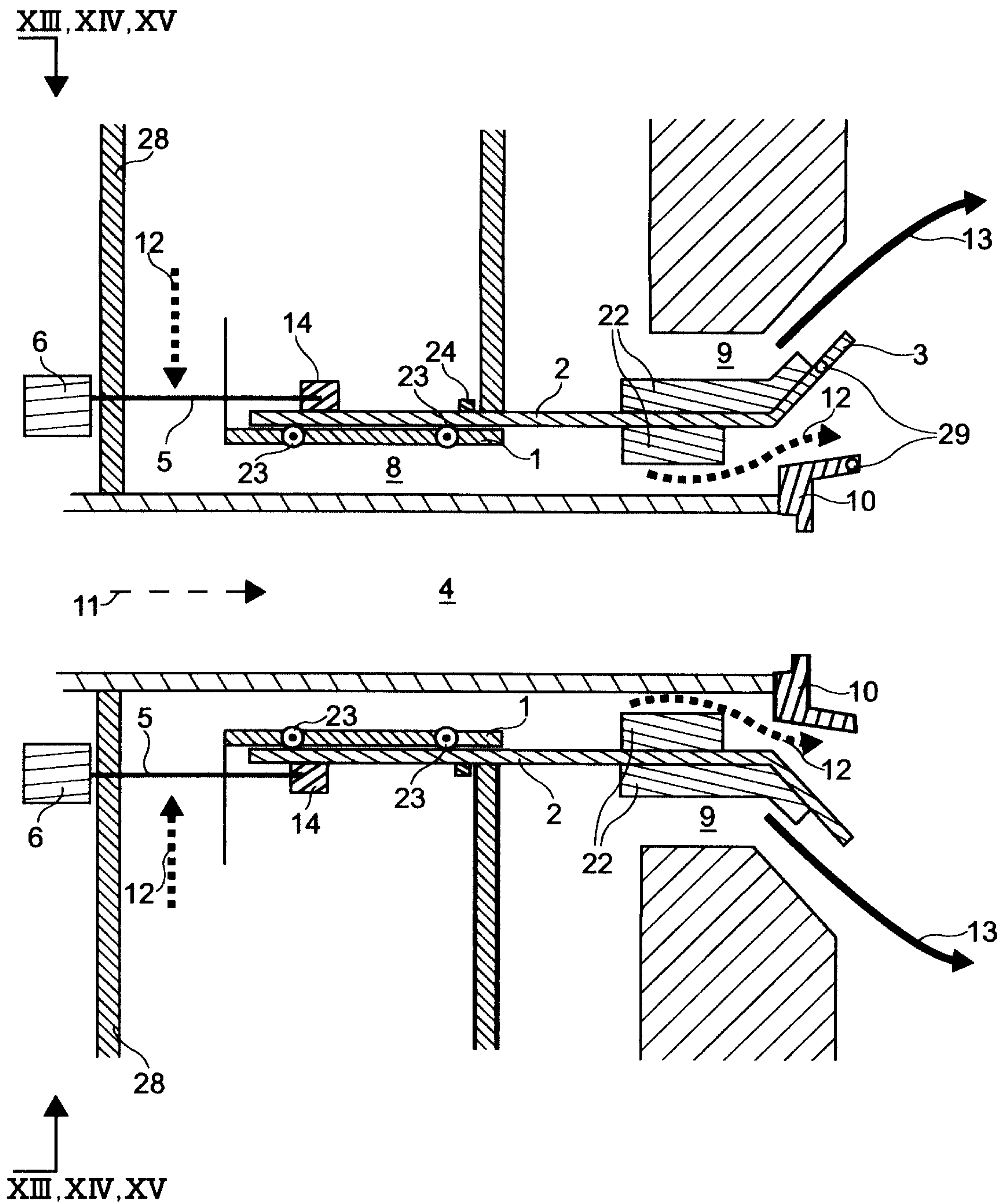
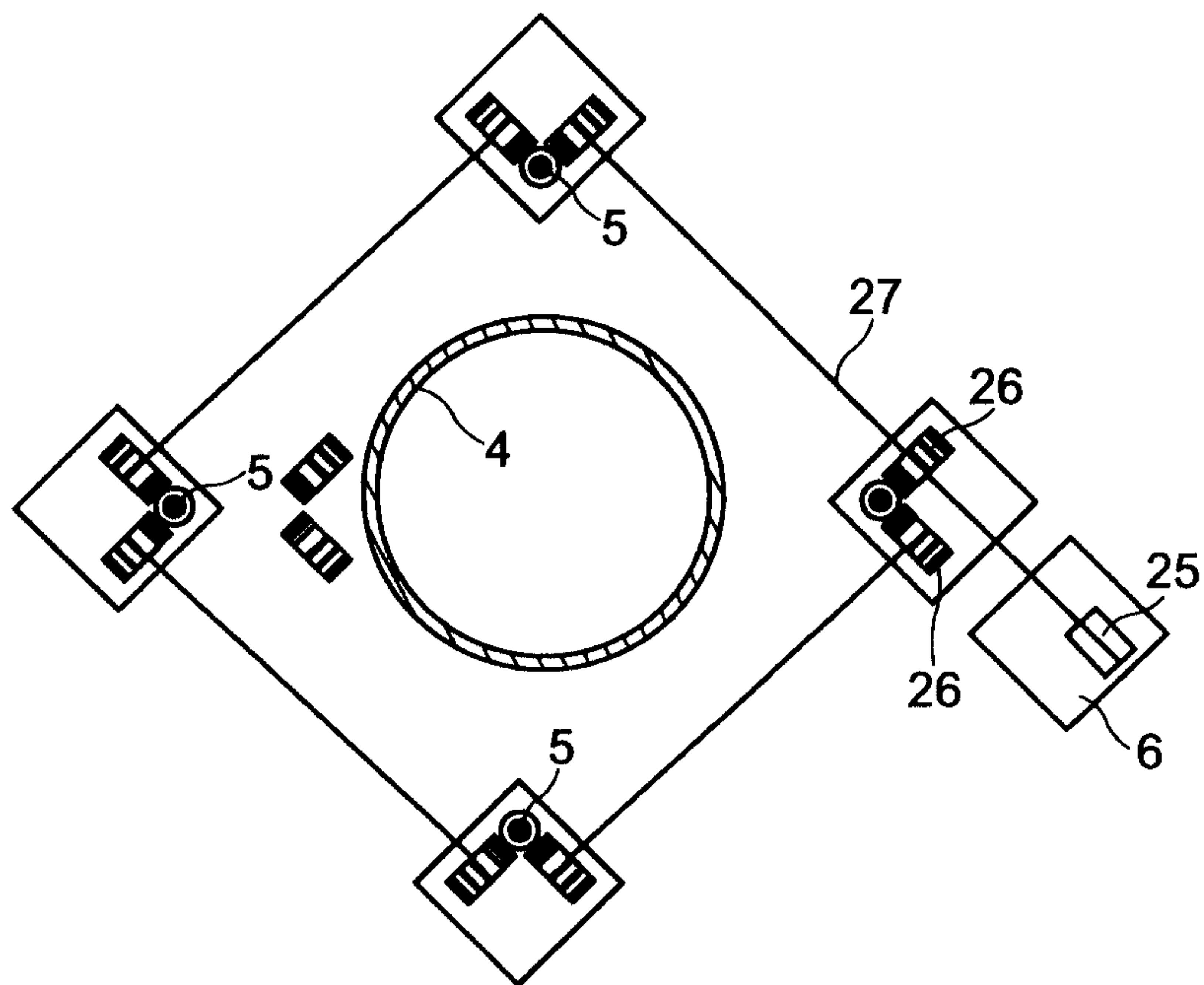

FIG. 12



**FIG. 13**



**FIG. 14**

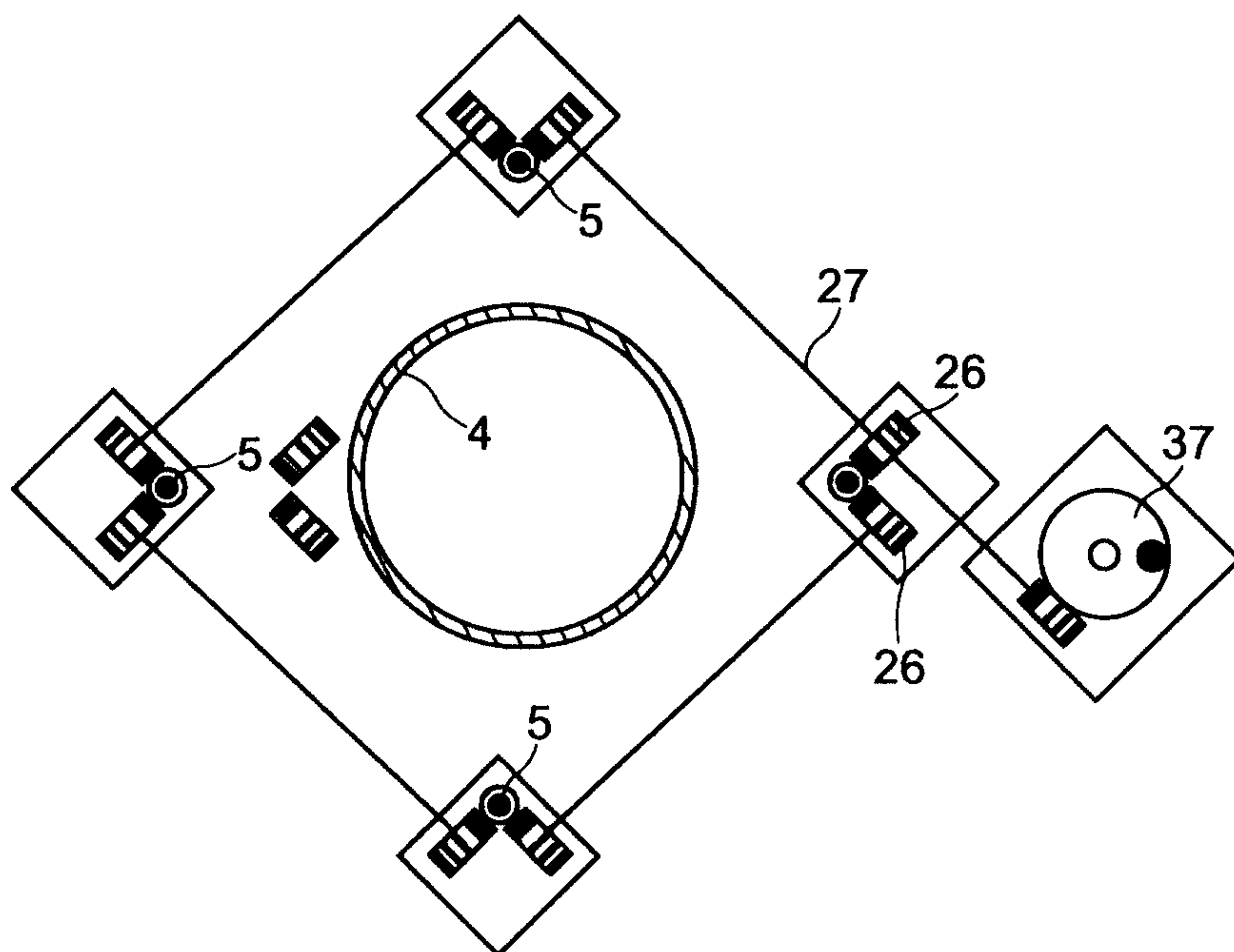

**FIG. 15**

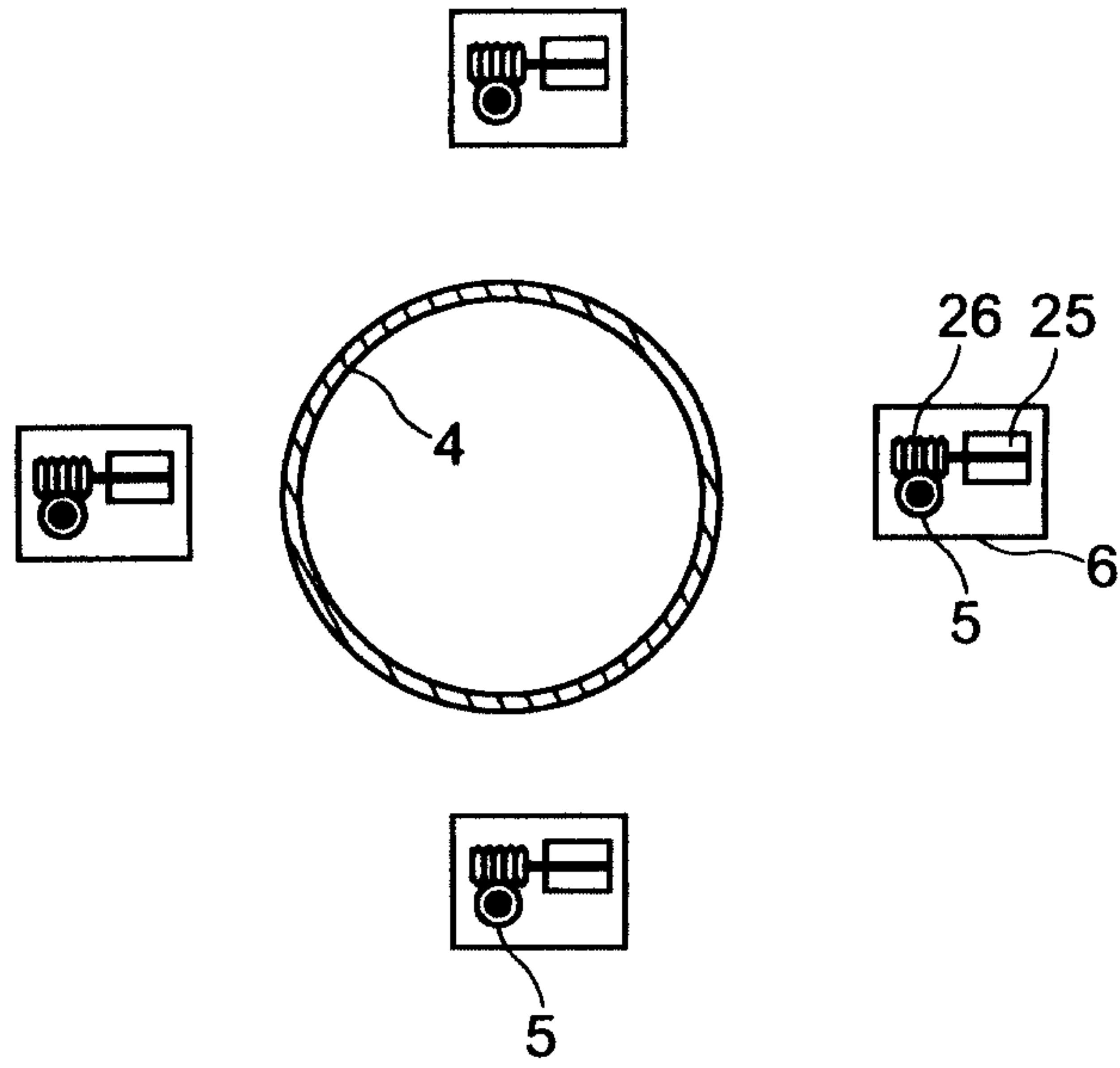
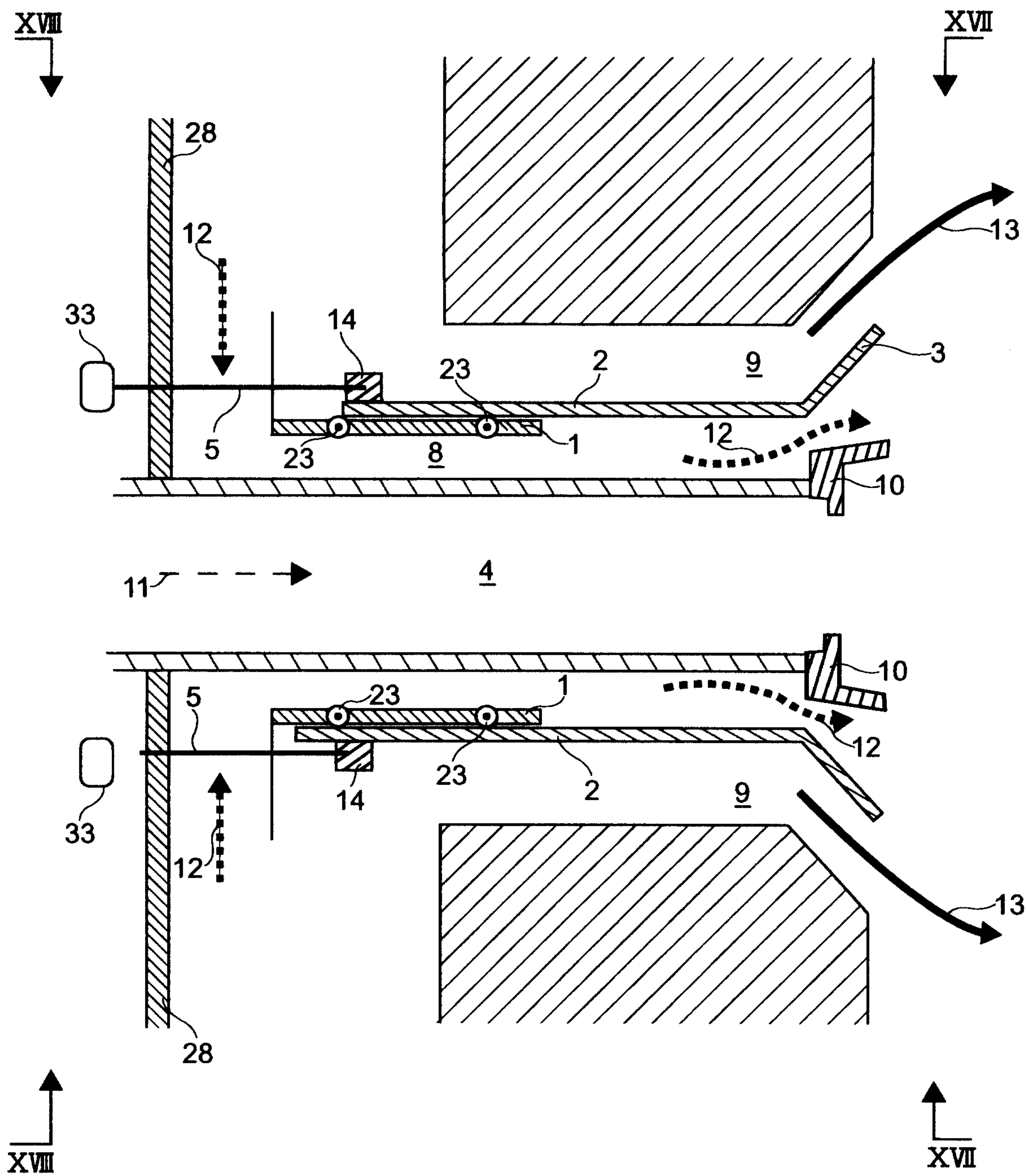
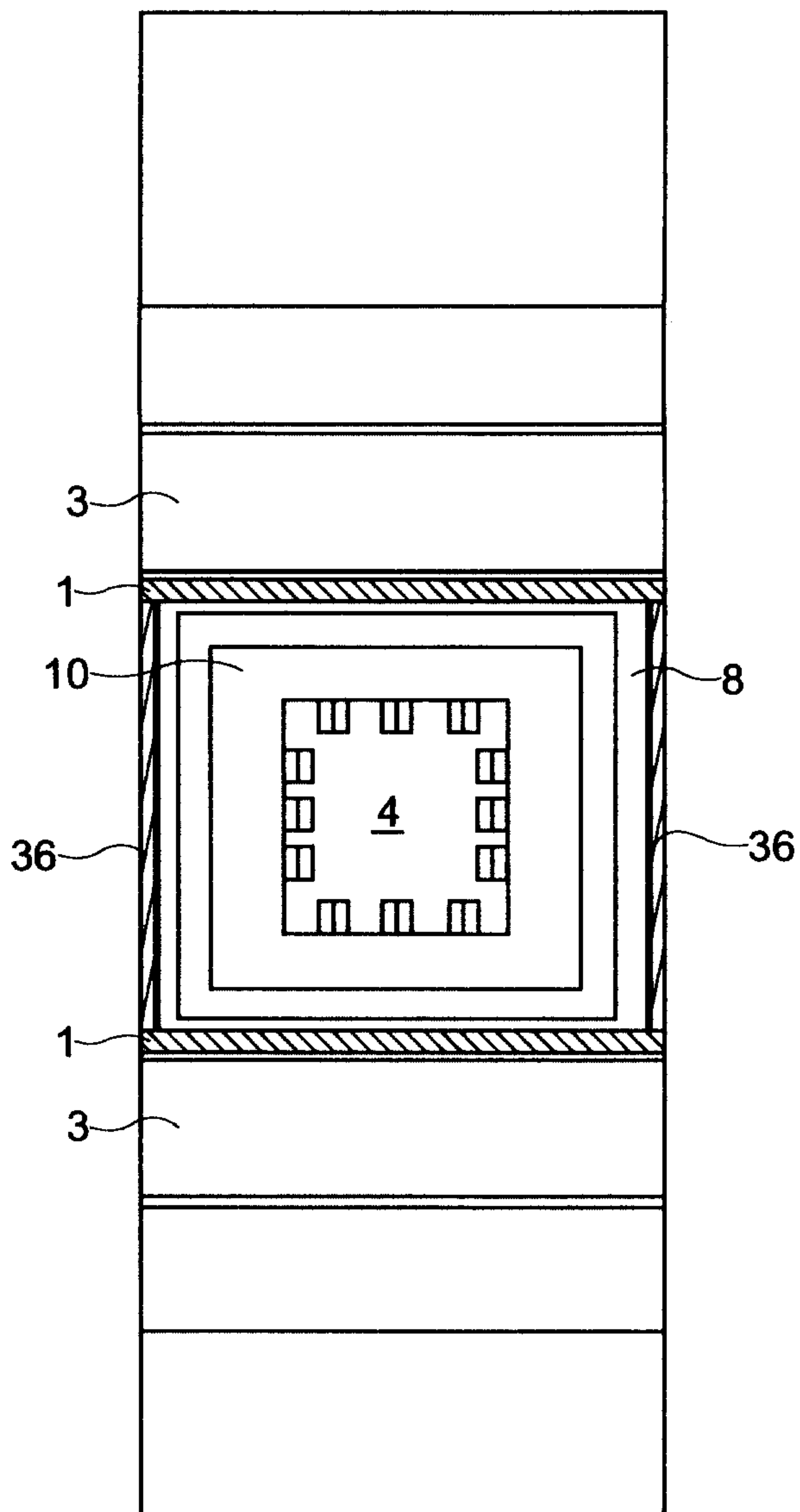

FIG. 16



**FIG. 17**



**FIG. 18**

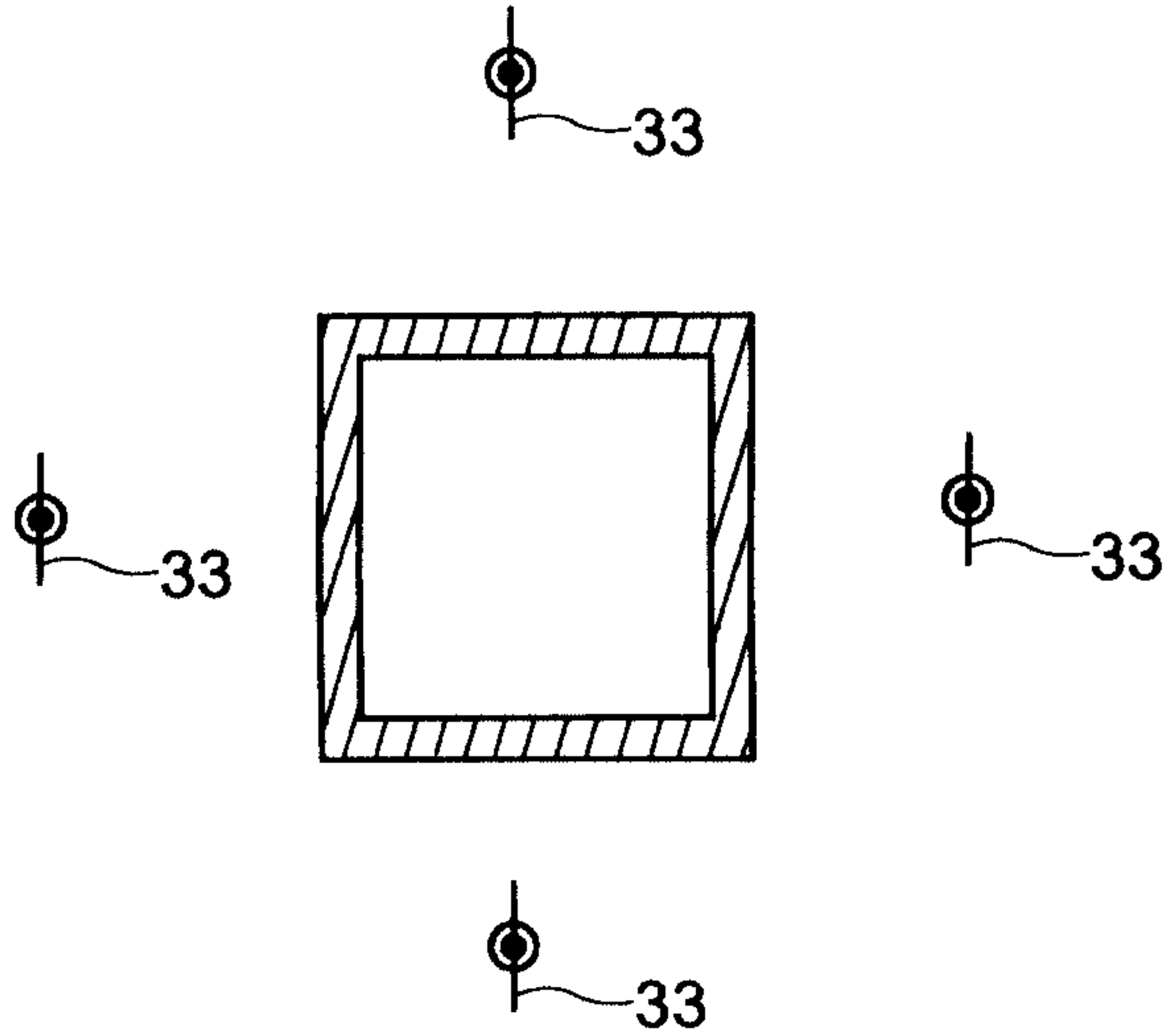

**FIG. 19**

