



(86) **Date de dépôt PCT/PCT Filing Date:** 2003/06/19  
(87) **Date publication PCT/PCT Publication Date:** 2004/02/05  
(45) **Date de délivrance/Issue Date:** 2016/04/26  
(85) **Entrée phase nationale/National Entry:** 2005/01/25  
(86) **N° demande PCT/PCT Application No.:** SE 2003/001055  
(87) **N° publication PCT/PCT Publication No.:** 2004/011051  
(30) **Priorité/Priority:** 2002/07/29 (US60/398,825)

(51) **Cl.Int./Int.Cl. A61L 27/30** (2006.01),  
**A61L 27/28** (2006.01), **A61L 27/34** (2006.01),  
**A61L 27/50** (2006.01)  
(72) **Inventeur/Inventor:**  
FORSELL, PETER, CH  
(73) **Propriétaire/Owner:**  
PROSTHESICA AG, CH  
(74) **Agent:** FETHERSTONHAUGH & CO.

(54) **Titre : IMPLANT DURABLE**  
(54) **Title: DURABLE IMPLANT**

(57) **Abrégé/Abstract:**

An implant (2) for use inside a human body comprises a biocompatible self-supporting base material (12), such as silicone, having surfaces exposed to aggressive body cells, when the implant is implanted in the human body. A cell barrier coating (14), such as Parylene<sup>®</sup> or a biocompatible metal, is coated on the surfaces of the base material to prevent body cells from breaking down the base material.



## (12) INTERNATIONAL APPLICATION PUBLISHED UNDER THE PATENT COOPERATION TREATY (PCT)

(19) World Intellectual Property  
Organization  
International Bureau



(43) International Publication Date  
5 February 2004 (05.02.2004)

PCT

(10) International Publication Number  
**WO 2004/011051 A1**

- (51) International Patent Classification<sup>7</sup>: **A61L 27/30**, 27/34
- (21) International Application Number: PCT/SE2003/001055
- (22) International Filing Date: 19 June 2003 (19.06.2003)
- (25) Filing Language: English
- (26) Publication Language: English
- (30) Priority Data: 60/398,825 29 July 2002 (29.07.2002) US
- (71) Applicant (for all designated States except US): **POTENCIA MEDICAL AG** [CH/CH]; Zugerstrasse 74, CH-6341 Baar (CH).
- (72) Inventor; and
- (75) Inventor/Applicant (for US only): **FORSELL, Peter** [SE/CH]; Aegeristrasse 66, CH-6300 Zug (CH).
- (74) Agent: **HAGSTRÖM, Leif**; Bergenstråhle & Lindvall AB, P.O. Box 17704, S-118 93 Stockholm (SE).
- (81) Designated States (*national*): AE, AG, AL, AM, AT, AU, AZ, BA, BB, BG, BR, BY, BZ, CA, CH, CN, CO, CR, CU, CZ, DE, DK, DM, DZ, EC, EE, ES, FI, GB, GD, GE, GH, GM, HR, HU, ID, IL, IN, IS, JP, KE, KG, KP, KR, KZ, LC, LK, LR, LS, LT, LU, LV, MA, MD, MG, MK, MN, MW, MX, MZ, NI, NO, NZ, OM, PH, PL, PT, RO, RU, SC, SD, SE, SG, SK, SL, TJ, TM, TN, TR, TT, TZ, UA, UG, US, UZ, VC, VN, YU, ZA, ZM, ZW.
- (84) Designated States (*regional*): ARIPO patent (GH, GM, KE, LS, MW, MZ, SD, SL, SZ, TZ, UG, ZM, ZW), Eurasian patent (AM, AZ, BY, KG, KZ, MD, RU, TJ, TM), European patent (AT, BE, BG, CH, CY, CZ, DE, DK, EE, ES, FI, FR, GB, GR, HU, IE, IT, LU, MC, NL, PT, RO, SE, SI, SK, TR), OAPI patent (BF, BJ, CF, CG, CI, CM, GA, GN, GQ, GW, ML, MR, NE, SN, TD, TG).

**Published:**

— with international search report

For two-letter codes and other abbreviations, refer to the "Guidance Notes on Codes and Abbreviations" appearing at the beginning of each regular issue of the PCT Gazette.

(54) Title: DURABLE IMPLANT

(57) Abstract: An implant (2) for use inside a human body comprises a biocompatible self-supporting base material (12), such as silicone, having surfaces exposed to aggressive body cells, when the implant is implanted in the human body. A cell barrier coating (14), such as Parylene<sup>®</sup> or a biocompatible metal, is coated on the surfaces of the base material to prevent body cells from breaking down the base material.

WO 2004/011051 A1

23038-181

1

**DURABLE IMPLANT**

The present invention relates to an implant for use inside a human body.

There is a great variety of implants for use inside  
5 the human body. A typical biocompatible material generally  
used for making these implants is silicone. Making implants of  
silicone is most beneficial for reasons of production and  
function. However, It has been indicated that silicone might  
be involved in diseases that create fibrosis - such as SLE  
10 (Systemic Lupus Eromatodus), although there is no evidence that  
this is the case. It is established, however, especially from  
breast-implants, that silicone implants in the human body do  
not last forever - 50% of implanted silicone implants were  
broken after 15 years, according to a large article published  
15 in the Lancet a couple of years ago. This indicates that the  
human body, at least to some extent, might break down the  
silicone material. Many other materials used for implants like  
polyurethane, Teflon™ based material, or similar polymers, or  
combinations thereof, may have the same problem.

20 The object of the present invention is to provide a  
durable implant with a long lifetime.

Accordingly, the present invention provides an  
implant for use inside a human body comprising a composite  
structure adapted to extend around and constrict a tubular  
25 organ of the human body, comprising: a biocompatible self-  
supporting base material comprising a layer of polyurethane and  
a layer of silicone or a layer of silicone surrounded by a  
layer of polyurethane or a layer of polyurethane surrounded by

23038-181

1a

a layer of silicone, and having surfaces adapted to be exposed to aggressive body cells, when the implant is implanted in the human body, a cell barrier coating comprising a poly(p-xylylene) polymer or a biocompatible metal coating that  
5 is coated on said base material surfaces and adapted to prevent body cells from breaking down said base material when the implant is implanted in the human body or for improving at least one physical property of the constriction device other than the constriction device being self-supporting.

10           Generally, the base material comprises hard silicone, typically having a hardness of at least 60 Shore.

In research by the inventor he has found small histological silicone particles in the fat around implanted silicone implants. Based on these facts the inventor has  
15 concluded that the human body with the macrophages in the frontline slowly destroys silicone, which could explain the

occurrence of silicone particles in the fat surrounding the implants. It is well known that foreign material, like silicone, creates an active fibrosis surrounding the foreign material. Therefore, if histological particles were spread out  
5 these would most likely also create fibrosis around them. To prevent histological silicone particles from spreading in the human body, and perhaps follow the lymphatic passageway, the inventor has realized that a barrier coating, which cannot be penetrated by body cells would protect the silicone implant  
10 from the body cells.

Prefarably, the barrier coating comprises a Parylene™ coating, or a biocompatible metal coating, such as gold, silver or titanium.

Advantageously, the implant comprises a property  
15 improving means for improving at least one physical property of the implant other than self-supporting and cell barrier properties. For example, the property improving means may comprise a core of a viscoelastic material, such as silicone gel, cellulose gel or collagen gel, covered with the self-  
20 supporting base material.

The property improving means may also comprise a fatigue resistant material. For example, the base material may form a first layer covered with a second layer, such as a polyurethane layer, that is more fatigue resistant than the first layer.

25 The property improving means may also comprise gas, such as air, contained in a multiplicity of cavities formed in the base material to improve the flexibility of the base material. In this case, Teflon™ advantageously constitutes the base material. The cavities may be defined by net structures of the  
30 Teflon™ material.

In an embodiment of the invention, the base material forms an inflatable tubing. The tubing may have an inner surface defining the interior of the tubing, wherein the coating covers the inner surface. In accordance with an

alternative, the base material may form two coaxial tubular layers of the tubing and the property improving means may comprise a tubular intermediate layer of the viscoelastic material, which is located between the coaxial tubular layers.

5 In accordance with another alternative, the base material may form an outer tubular layer and an inner arcuate layer attached to the outer tubular layer, so that the outer and inner layers define a curved space extending longitudinally along the tubing, wherein the property improving means comprises  
10 viscoelastic material filling the space. In accordance with yet another alternative, the base material forms an inflatable tubing and the property improving means comprises a liquid impermeable coating coated on the base material. The coating may be coated on the external and/or internal surface of the  
15 tubing. Preferably, the liquid impermeable coating comprises a Parylene™ coating, or a biocompatible metal coating. Where hard silicone, which is a liquid semi-permeable material, constitutes the base material, the coating of Parylene™ or metal gives the advantage that the tubing may be inflated by  
20 hydraulic fluid under pressure without risking fluid diffusing through the silicone wall of the tubing.

The barrier coating may comprise a composite of different materials to achieve the cell-barrier protection as described above. There are several examples of such composite materials  
25 on the market, for example a composite of polyurethane and silicone called Elaston™.

The invention is described in more detail in the following with reference to the accompanying drawings, in which:

30 Figure 1 is a front view of an implant according to the present invention in the form of mechanical constriction device,

Figure 2 is an enlarged cross-section along the line II-II in Figure 1,

Figures 3 and 4 are modifications of the embodiment shown in Figure 2,

Figure 5 is a front view of an implant according to the invention in the form of a hydraulic constriction device,

5 Figure 6 is an enlarged cross-section along the line VI-VI in Figure 5,

Figures 7 -10 are modifications of the embodiment shown in Figure 6, and

10 Figure 11 is a modification of the embodiment shown in Figure 2.

Referring to the drawing figures, like reference numerals designate identical or corresponding elements throughout the several figures.

Figure 1 illustrates an implant according to the present invention in the form of a mechanical constriction device 2 comprising an elongate composite structure 4 adapted to extend around and constrict the stomach or esophagus of an obese patient to form a restricted stoma opening therein. Referring to Figure 2, the elongate composite structure 4 comprises a strong band 6 of nylon or the like, a tubular layer 8 of hard silicone, in which the band 6 slides, a soft layer 10 of a viscoelastic material, here a silicone gel having a hardness not more than 20 Shure, encircling the hard silicone layer 8, and a tubular layer 12 of a self-supporting base material of hard silicone having a hardness of at least 60 Shure, surrounding the soft silicon layer 10. A barrier coating 14 of Parylene™ or a biocompatible metal, such as gold, silver or titanium, is coated on the outer hard silicone layer 12 to prevent body cells from attacking the silicone. A coating of Teflon™ or the like may also be coated on the internal surface of the inner tubular hard silicone layer 8 to reduce the friction between the nylon band 6 and the layer 8. The constriction device 2 has an adjustment means 16 that can displace the end portions of the nylon band 6 relative to each

15  
20  
25  
30

other to either enlarge or constrict the stoma opening.

Figure 3 shows an elongate composite structure 18 similar to that of Figure 2, except that a layer 20 of a fatigue resistant material, here polyurethane, is applied on the hard  
5 silicone layer 12 along the inner side of the structure 18 that is intended to contact the stomach or esophagus. Alternatively, the layer 20 may be tubular and surround the layer 12.

Figure 4 shows a cross-section of an elongate composite structure 22 of an embodiment of the invention, in which the  
10 self-supporting base material comprises Teflon™. The base material forms a longitudinal cavity in which a strong nylon band 24 slides. Property improving means in the form of gas, here air, contained in a multiplicity of cavities 26 are formed in the base material to improve the flexibility  
15 thereof. The external surface of the composite structure is coated with a cell barrier coating.

Figure 5 shows an implant according to the invention in the form of a hydraulic constriction device 28 comprising an elongate composite structure in the form of an inflatable  
20 tubing 30, in which the base material of hard silicone forms an outer tubular layer 32 and an inner coaxial layer 34. A viscoelastic material, here soft silicone gel, forms an intermediate layer 36 located between the tubular layers 32,34. Four longitudinal partition walls 38 between the tubular layers  
25 32,34 divide the intermediate layer 36 into four sections to prevent the silicone gel from displacing in the circumferential direction of the tubing 30. (Also the embodiments according to Figures 2 and 3 may be provided with such longitudinal partition walls.) The outer layer 32 is coated with a barrier  
30 coating 40 of Parylene™ or metal. Also the inner layer 34 may be coated with a coating of Parylene™ or metal. If a Parylene™ or metal coating is chosen the composite structure will be completely liquid impermeable.

Figure 7 shows a tubing 42 similar to that of Figure 6,

except that an inner arcuate layer 44 is substituted for the inner tubular layer 34. The arcuate layer 44 is attached to the outer tubular layer 32, so that the outer tubular layer 32 and the arcuate layer 44 define a curved space extending  
5 longitudinally along the tubing 42. A viscoelastic material, here silicone gel 46, fills the space. In this embodiment there is no need for partition walls of the kind shown in the embodiment according to Figure 6. The tubing 42 is intended to be applied around the stomach or esophagus so that the space  
10 with the protecting soft silicone gel 46 is located close to the stomach or esophagus.

As taught by the embodiment of Figure 7, in the composite structures shown in Figures 2 and 3 the soft silicone gel may alternatively be applied in a longitudinal space close to the  
15 inner side of the elongate composite structure 4 and 18, respectively, that is intended to contact the stomach or esophagus.

In the same manner as described above in connection with the embodiment of Figure 3, a layer of a fatigue resistant  
20 material, here polyurethane, may be applied on the outer tubular layer 32 of hard silicone of the tubing 30 and 42, respectively, along the side of the tubing 30 and 42, respectively, that is intended to contact the stomach or esophagus, when the tubing 30 and 42, respectively, encircles  
25 the stomach or esophagus.

Figure 8 shows a cross-section of an elongate composite structure 48 of an embodiment of the invention, in which Teflon™ constitutes the self-supporting base material, which  
~~is formed to an inflatable tubing 50.~~ Property-improving means  
30 in the form of gas contained in a multiplicity of cavities 26 are formed in the base material to improve the flexibility of the tubing 50. The external surface of the composite structure is coated with a cell barrier coating.

Figure 9 shows a cross-section of a tubular composite

structure of an embodiment of the invention, in which the self-supporting base material 52 is made of a polymer material suited for implantation, for example silicone or polyurethane. A cell barrier coating 54, for example made of Parylene™ or metal, is applied on the external surface or on both the external and internal surfaces of the tubular structure

Figure 10 shows the same embodiment as Figure 9 except that the base material comprises a layer 56 of polyurethane surrounded by a layer 58 of silicone.

Figure 11 shows a cross-section of a mechanical constriction device of another embodiment of the invention, comprising a double-walled tubing 60 of a self-supporting base material of hard silicone. The tubing 60 has an external wall 62 and an internal wall 64 spaced from the external wall 62, partition walls 66 dividing the space between the external and internal walls 62 and 64, respectively, of the tubing 60 into longitudinal cells 68, which are filled with a soft viscoelastic material, for example silicone gel. The internal wall 64 is coated with a friction reducing coating 70, for example made of Teflon™ or the like. A strong band 72 of nylon or the like slides in the tubing 60 on the friction reducing coating 70 to enable adjustment of the constriction device in the same manner as described above in connection with the embodiment according to Figures 1 and 2. The external surface of the composite structure is coated with a cell barrier coating.

Although the present invention has been described in terms of particular embodiments, it is not intended that the invention be limited to those embodiments. Modifications of the embodiments within the spirit of the invention will be apparent to those skilled in the art. The scope of the invention is defined by the claims that follow.

23038-181

8

CLAIMS:

1. An implant for use inside a human body comprising a composite structure adapted to extend around and constrict a tubular organ of the human body, comprising:

5 a biocompatible self-supporting base material comprising a layer of polyurethane and a layer of silicone or a layer of silicone surrounded by a layer of polyurethane or a layer of polyurethane surrounded by a layer of silicone, and having surfaces adapted to be exposed to aggressive body cells,  
10 when the implant is implanted in the human body,

a cell barrier coating comprising a poly(p-xylylene) polymer or a biocompatible metal coating that is coated on said base material surfaces and adapted to prevent body cells from breaking down said base material when the implant is implanted  
15 in the human body or for improving at least one physical property of the constriction device other than the constriction device being self-supporting.

2. The implant according to claim 1, further comprising a viscoelastic material covered by the base material, which  
20 comprises silicone gel, cellulose gel or collagen gel.

3. The implant according to claim 2 further comprising a band of nylon and a second, tubular layer of silicone in which the band slides, the band of nylon and the second, tubular layer of silicone being surrounded by the layer of viscoelastic  
25 material.

4. The implant according to claim 3, wherein the viscoelastic material is a silicone gel having a hardness of not more than 20 Shore.

23038-181

9

5. The implant according to claim 2, wherein the base material of silicone is a hard silicone having a hardness of at least 60 Shore.

6. The implant according to claim 1, wherein the  
5 biocompatible metal forming the barrier coating is gold, silver or titanium.

7. The implant according to claim 3, further comprising a coating of lubricant on an internal surface of the inner tubular layer of silicone to reduce friction between the nylon band  
10 and the inner tubular layer of silicone.

8. The implant according to claim 7, wherein the coating of lubricant is polytetrafluoroethylene (PTFE).

1/2

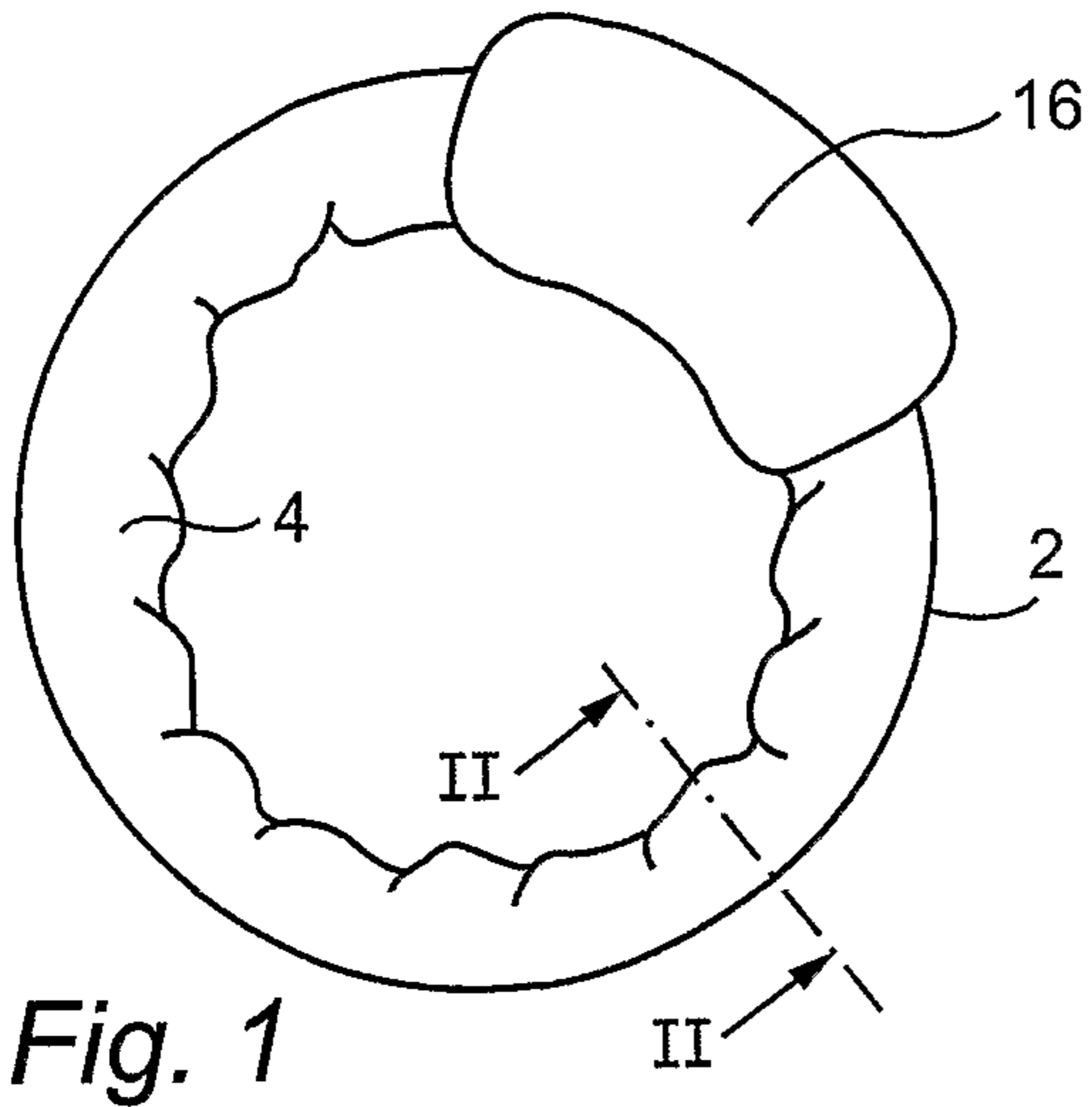

Fig. 1

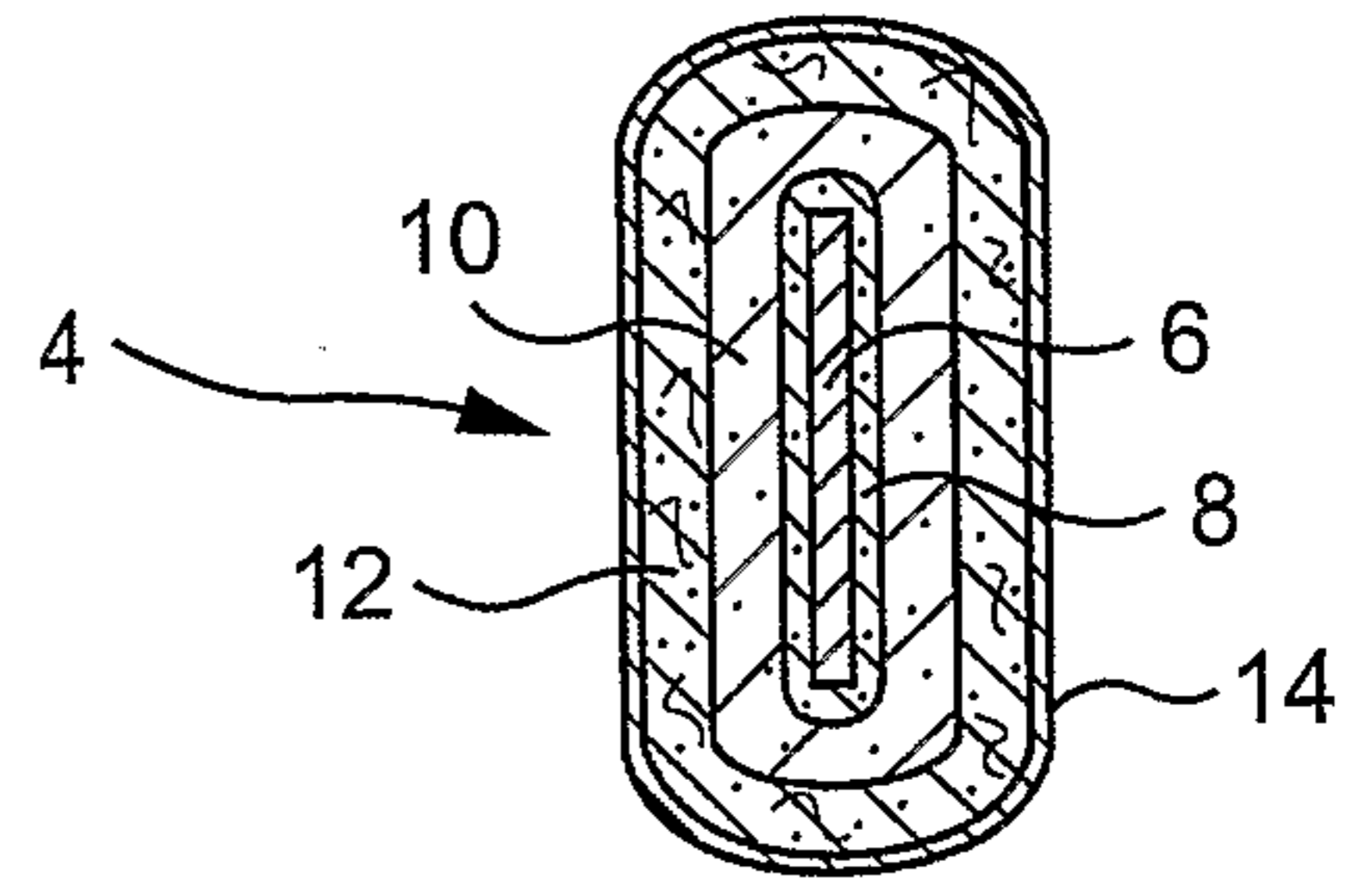

Fig. 2

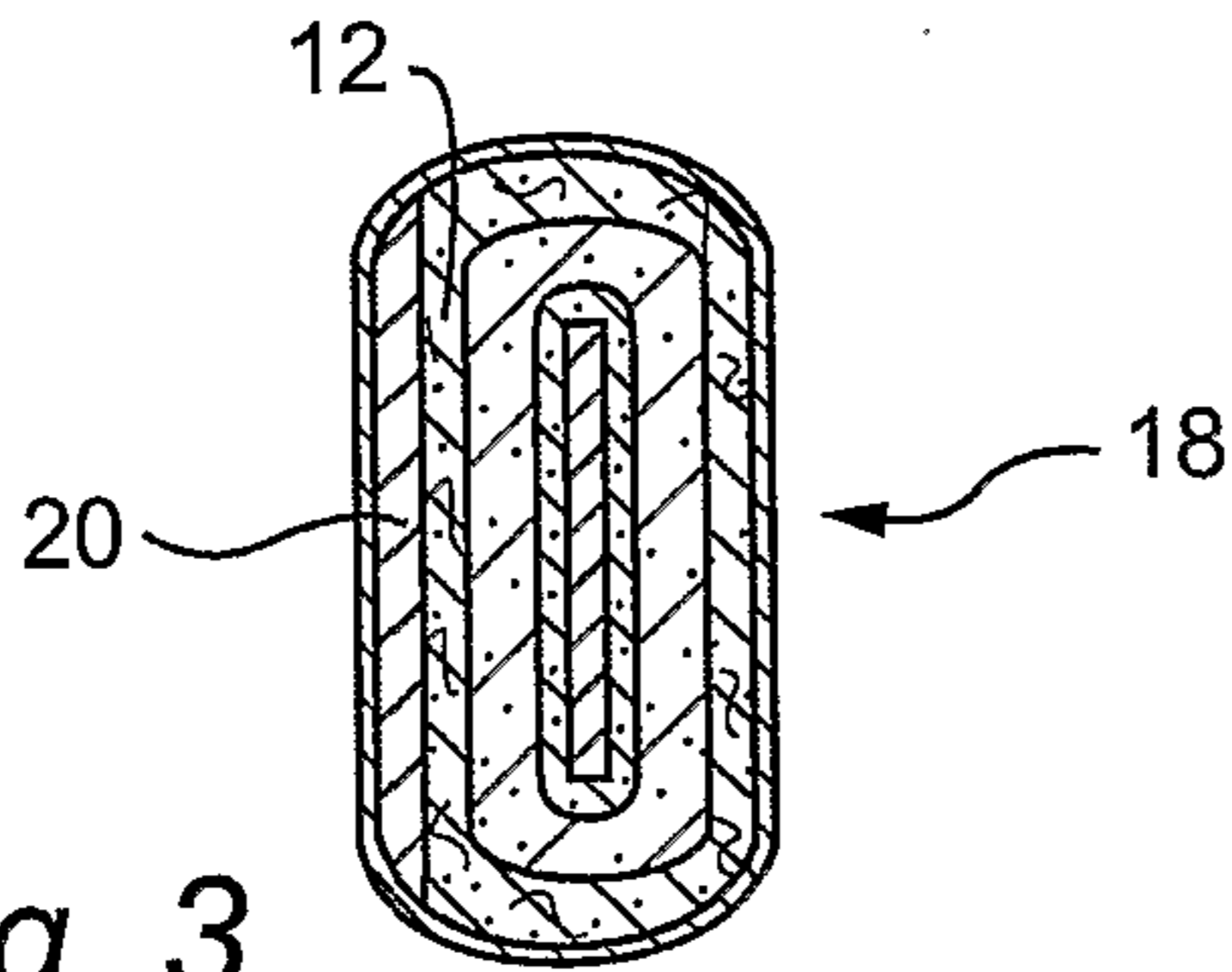

Fig. 3

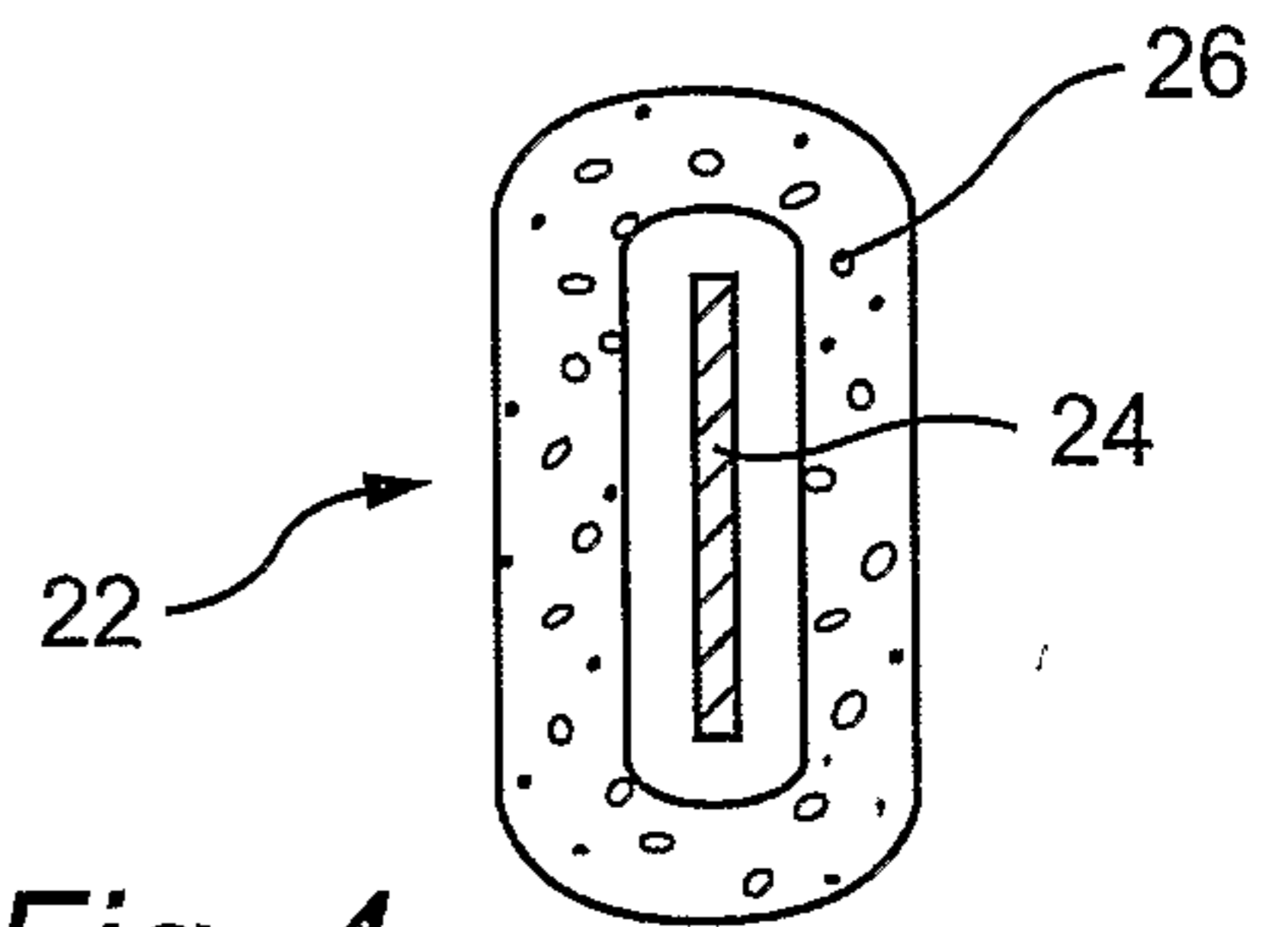

Fig. 4

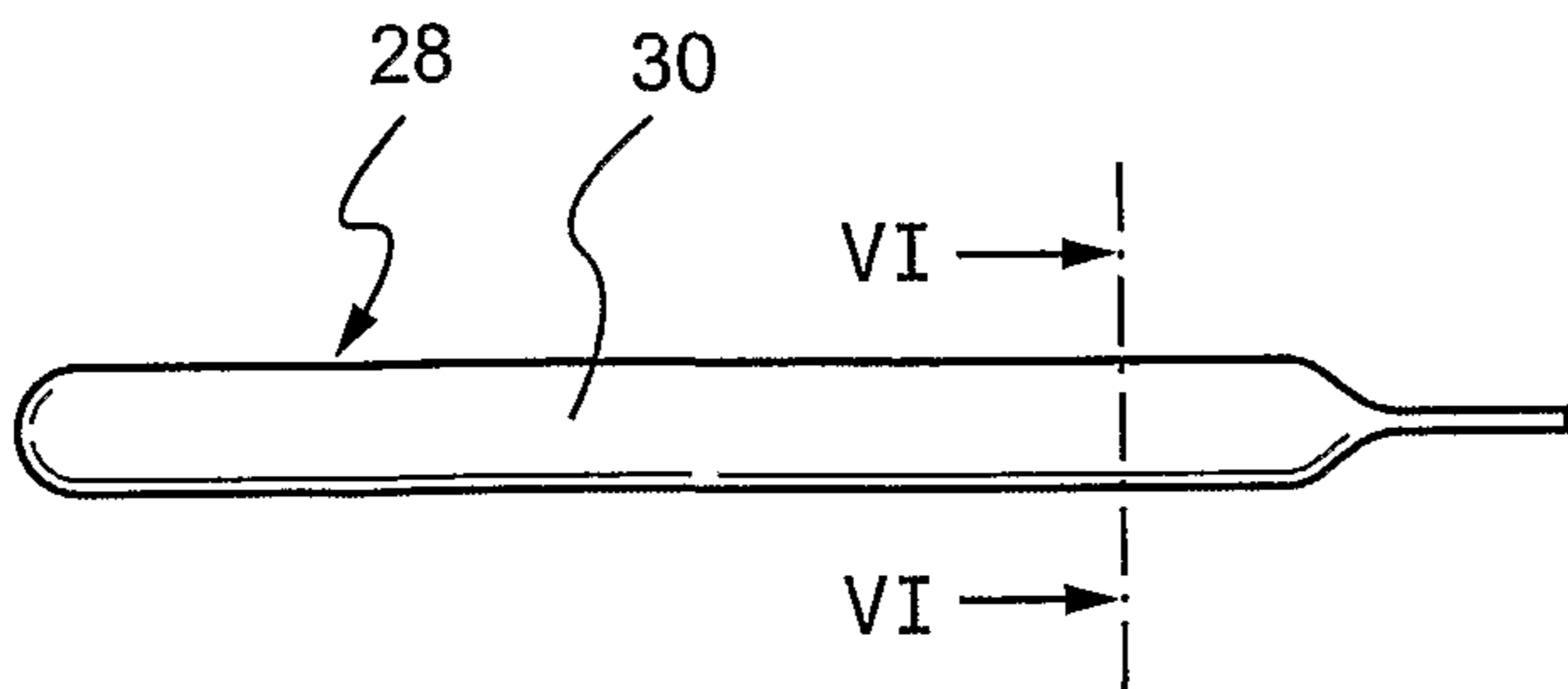

Fig. 5

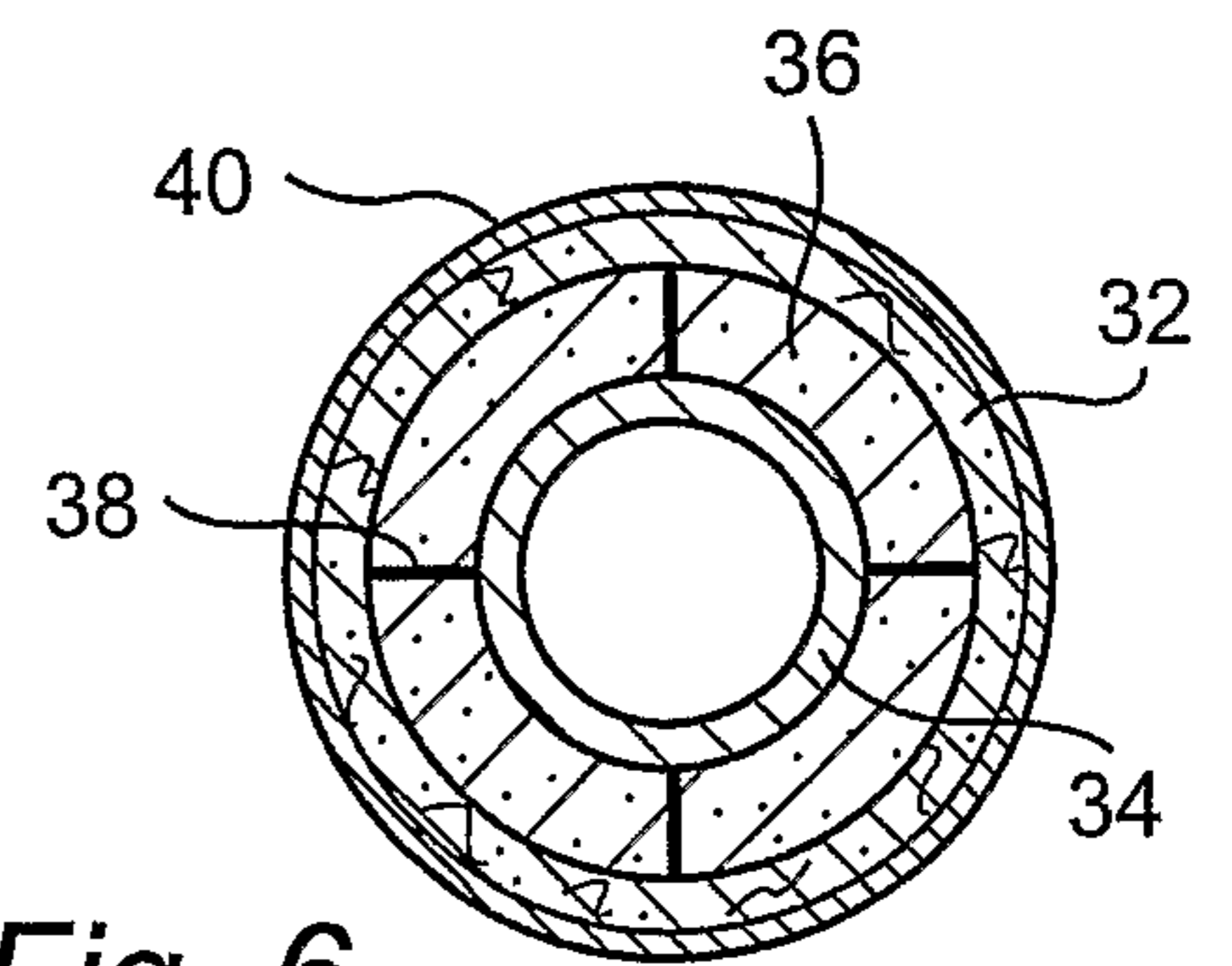

Fig. 6

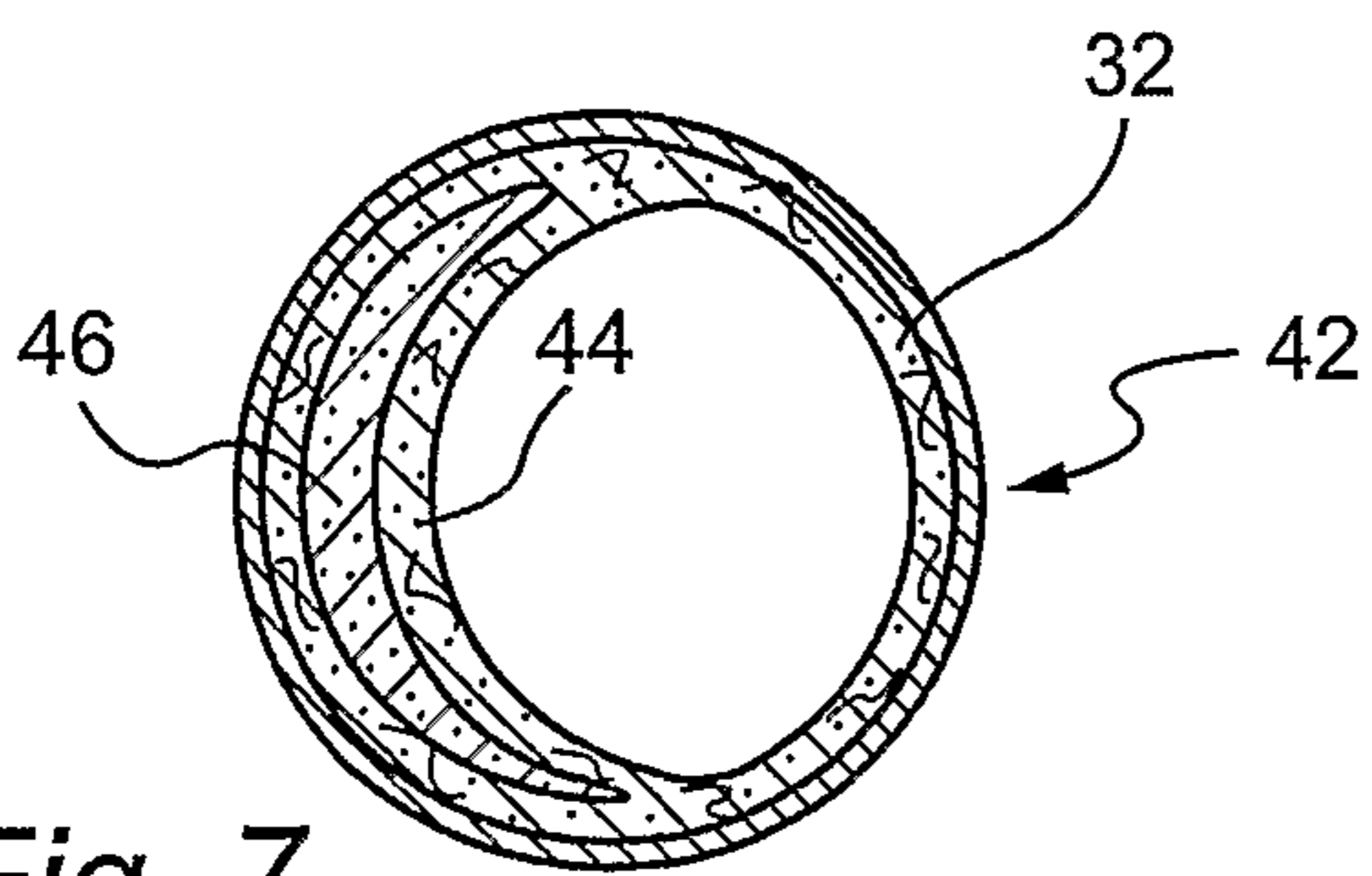

Fig. 7

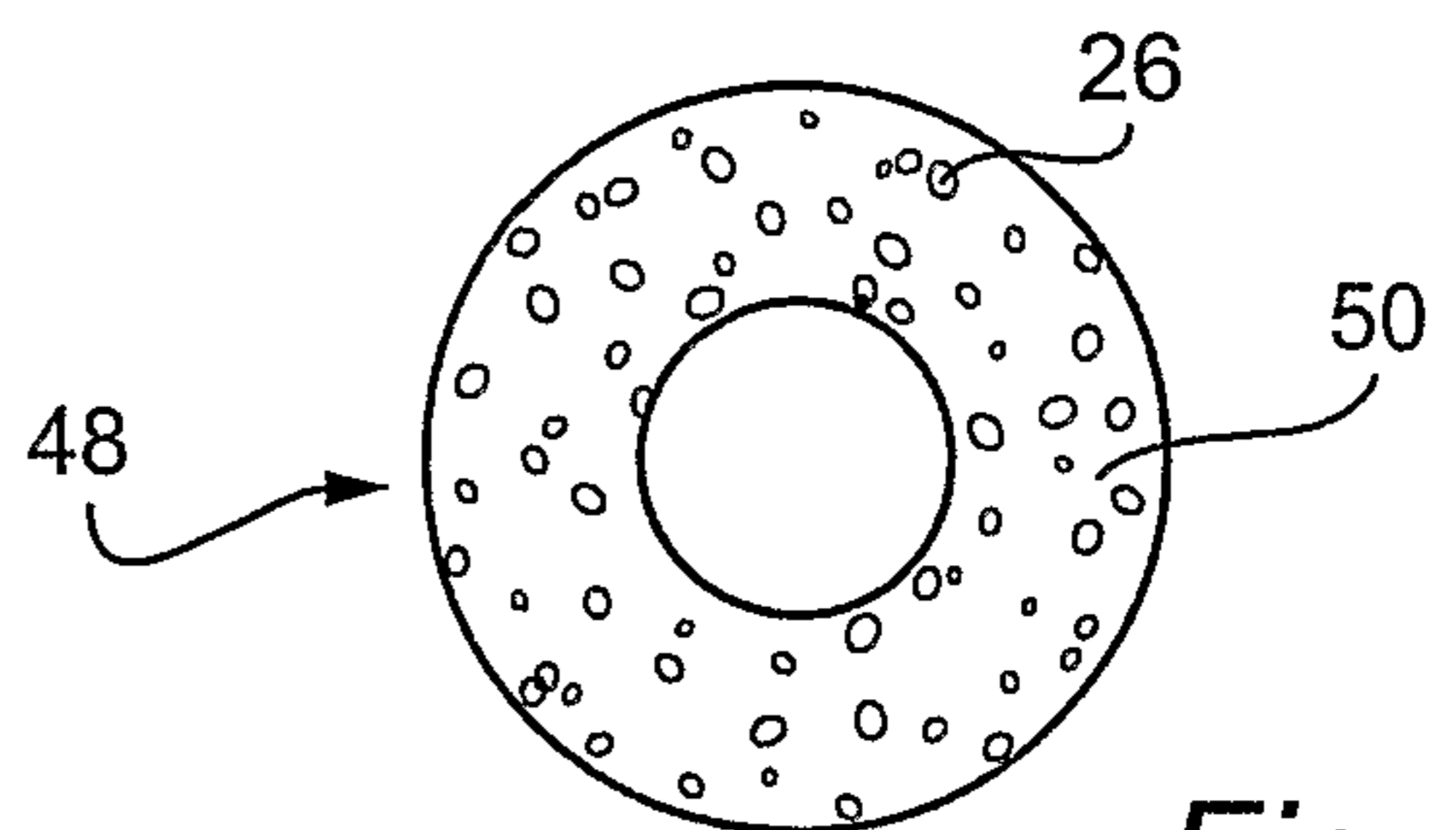

Fig. 8

2/2

Fig. 9

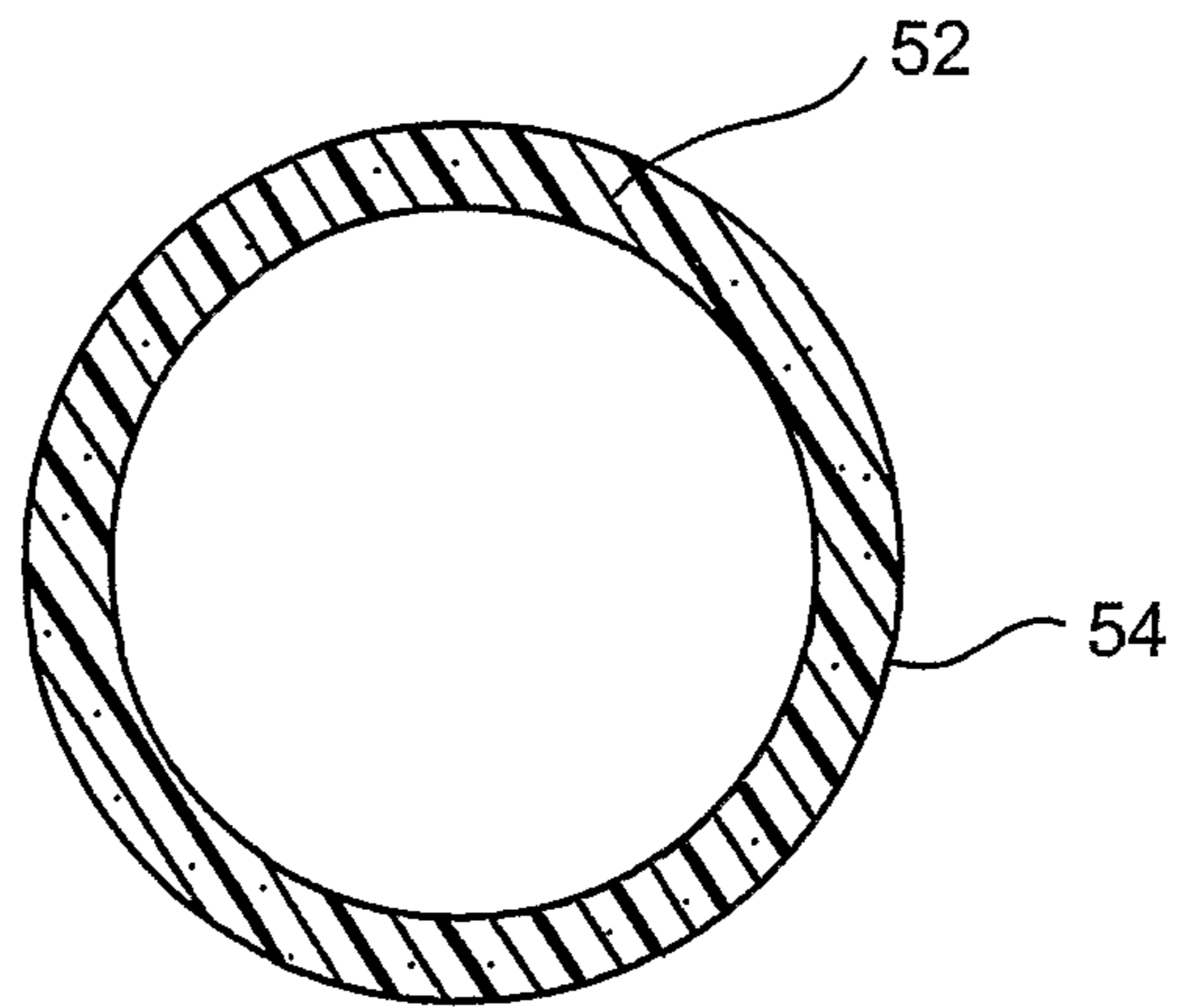

Fig. 10

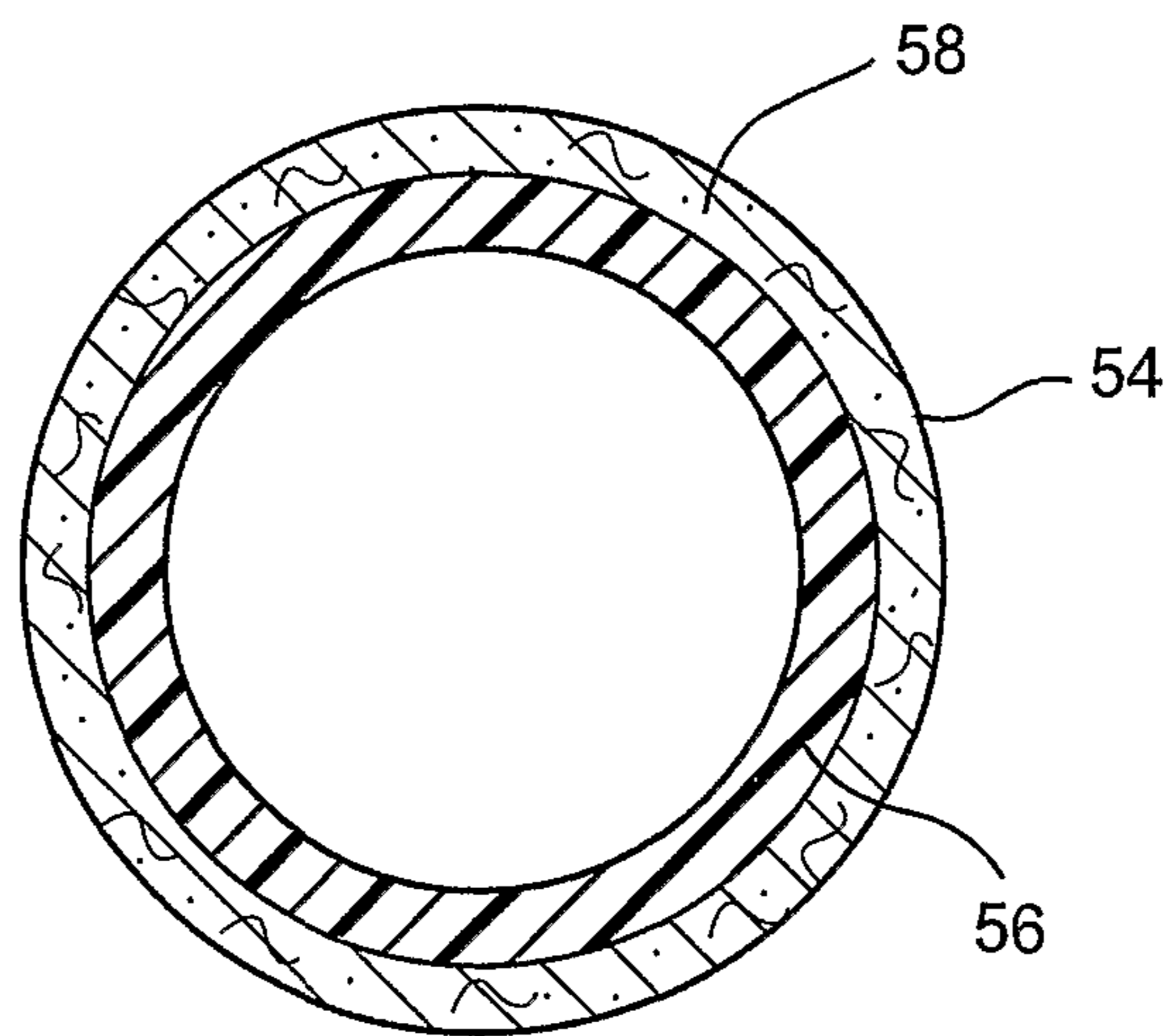

Fig. 11

