



(11) **EP 2 138 662 A2**

(12) **EUROPEAN PATENT APPLICATION**

(43) Date of publication:
30.12.2009 Bulletin 2009/53

(51) Int Cl.:
E05F 15/04^(2006.01) E05F 3/06^(2006.01)

(21) Application number: **09163898.1**

(22) Date of filing: **26.06.2009**

(84) Designated Contracting States:
AT BE BG CH CY CZ DE DK EE ES FI FR GB GR HR HU IE IS IT LI LT LU LV MC MK MT NL NO PL PT RO SE SI SK TR

(72) Inventor: **Yu, Rick**
Shetou Township, Changhua County (TW)

(30) Priority: **27.06.2008 TW 97124352**

(74) Representative: **Beck & Rössig**
European Patent Attorneys
Cuvilliesstrasse 14
81679 München (DE)

(71) Applicant: **Taiwan Fu Hsing Industrial Co. Ltd.**
Province of China (TW)

(54) **Automatic door closer**

(57) An automatic door closer comprises a casting 10, a sliding assembly 20, a drive assembly 30, a tube shaped piston 41 and a first resilient member 51. The casting 10 has a front chamber 111, a rear chamber 113, a middle chamber 112 in communication with the front chamber 111 and the rear chamber 113, a shaft hole 12 penetrating the middle chamber 112 and a first oil passage 13. The first oil passage 13 has an oil inlet 13a in communication with the front chamber 111 and an oil outlet 13b in communication with the rear chamber 113. The sliding assembly 20 disposed within the middle chamber 112 of the casting 10 comprises a slider 21 disposed between the oil inlet 13a and the oil outlet 13b, a first roller 22 and a second roller 23, wherein the first and

second rollers 22, 23 arc disposed within the slider 21 respectively. The drive assembly 30 comprises a shaft 31 and an eccentric cam 32 coupled to the shaft 31, the shaft 31 is pivotally disposed within the shaft hole 12 of the casting 10, the eccentric cam 32 is located within the slider 21 and contacts against the first and second rollers 22, 23 of the sliding assembly 20. The tube shaped piston 41 disposed within the rear chamber 113 of the casting 10 has a first end portion 411 and a second end portion 412 opposite to the first end portion 411, the first end portion 411 is connected with the first roller 22. The first resilient member 51 is disposed within the front chamber 111 of the casting 10 serving for pushing the slider 21 of the sliding assembly 20 to move.

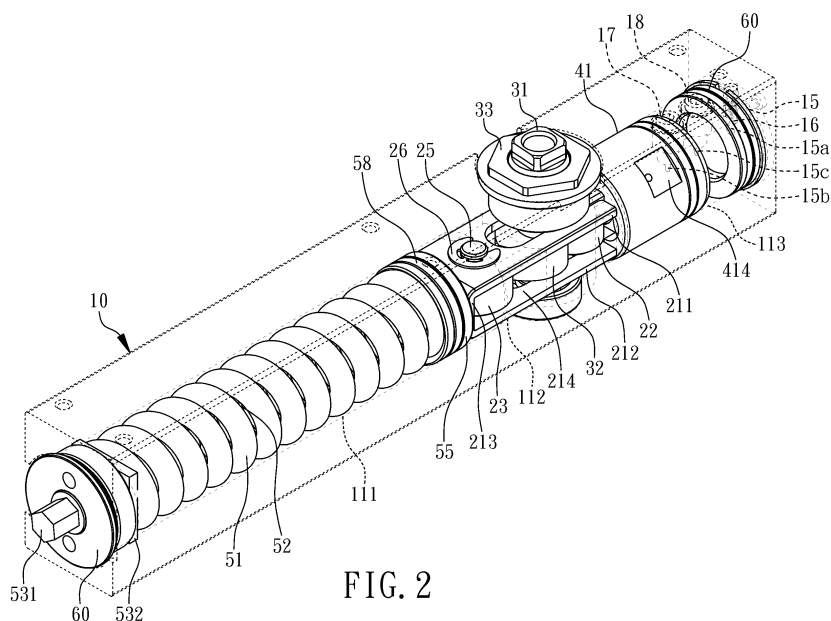

FIG. 2

EP 2 138 662 A2

Description

FIELD OF THE INVENTION

[0001] The present invention relates to a door closer, and more particularly to an automatic door closer, which applies sliding assembly and oil passage to enhance operating smooth.

BACKGROUND OF THE INVENTION

[0002] A door closer is typically used for providing a damping action against a door to generate a buffer effect when closing the door, and, a resilient member installed within the door closer can store energy during compression to automatically and slowly pull the door back and then restore a door-closing state when an exterior force is moved away from the door. For example, Taiwan Patent No. 428,658 discloses movement of a door closer which is performed by applying a wheel, a rack and a spring. However, the above-described door closer has a backlash when the wheel engages with the rack, and that backlash becomes larger and larger through long term attrition to make engagement of the wheel and the rack cause intermittent contact, which results in unsmooth operation of the door closer.

SUMMARY OF THE INVENTION

[0003] A primary object of the present invention is to provide an automatic door closer which overcomes the afore-described drawbacks inherent to the prior art.

[0004] This technical problem is solved by an automatic door closer according to claim 1. Advantageous embodiments are laid down in further claims.

[0005] The automatic door closer comprises a casting, a sliding assembly, a drive assembly, a tube shaped piston and a first resilient member. The casting has a front chamber, a rear chamber, a middle chamber in communication with the front chamber and the rear chamber, a shaft hole penetrating the middle chamber and a first oil passage. The first oil passage has an oil inlet in communication with the front chamber and an oil outlet in communication with the rear chamber. The sliding assembly disposed within the middle chamber of the casting comprises a slider disposed between the oil inlet and the oil outlet, a first roller and a second roller, wherein the first and second rollers are disposed within the slider respectively. The drive assembly comprises a shaft and an eccentric cam coupled to the shaft, the shaft is pivotally disposed within the shaft hole of the casting, the eccentric cam is located within the slider and contacts against the first and second rollers of the sliding assembly. The tube shaped piston disposed within the rear chamber of the casting has a first end portion and a second end portion opposite to the first end portion, the first end portion is connected with the first roller. The first resilient member is disposed within the front chamber of the casting serving

for pushing the slider of the sliding assembly to move.

[0006] Operating smooth of the automatic door closer can be improved via reciprocation of the slider and the tube shaped piston and action of the first oil passage according to the present invention.

DESCRIPTION OF THE DRAWINGS

[0007]

Fig.1 is a perspective exploded view of an automatic door closer in accordance with a preferred embodiment of the present invention.

Fig.2 is a perspective assembly view of the automatic door closer.

Fig.3 is a longitudinal section view of the automatic door closer.

Fig.4A-4B is an action transverse section view of the automatic door closer.

Fig.5 is a side view of the automatic door closer.

Fig.6A-6B is an action view of the automatic door closer taken along line A-A of Fig.5.

Fig.7 is another action view of the automatic door closer.

DETAILED DESCRIPTION OF THIS INVENTION

[0008] With reference to Fig.1, Fig.2 and Fig.3, an automatic door closer in accordance with a preferred embodiment of the present invention comprises a casting 10, a sliding assembly 20, a drive assembly 30, a piston assembly 40, an elastic assembly 50 and a pair of lid 60. The casting 10 is defined as a long oriented axis 10a and a short oriented axis 10b, where there are a front chamber 111, a rear chamber 113 and a middle chamber 112 in communication with the front chamber 111 and the rear chamber 113, which are located along the long oriented axis 10a. The casting 10 has a shaft hole 12 located along the short oriented axis 10b and penetrating the middle chamber 112. With reference to Fig.1 and Fig.6A, the front chamber 111, the middle chamber 112 and the rear chamber 113 are filled with hydraulic oil. There are disposed a first oil passage 13 in communication with the front chamber 111 and the rear chamber 113, a first check valve 14 located inside the first oil passage 13, a second oil passage 15 in communication with the rear chamber 113 and a second check valve 16 located inside the second oil passage 15 within the casting 10. The first oil passage 13 has an oil inlet 13a in communication with the front chamber 111 and an oil outlet 13b in communication with the rear chamber 113. The first check valve 14 is disposed adjacent to the oil outlet 13b of the first oil passage 13. The second oil passage 15 has an inlet 15a in communication with the rear chamber 113, a first outlet 15b and a second outlet 15c. The second check valve 16 is disposed adjacent to the inlet 15a of the second oil passage 15. In addition, the casting 10 further has a first speed control valve 17 disposed at the first

outlet 15b of the second oil passage 15 and a second speed control valve 18 disposed at the second outlet 15c of the second oil passage 15 applied for adjusting oil output of the first outlet 15b and the second outlet 15c respectively. With reference again to Fig.1, Fig.2 and Fig. 3, the sliding assembly 20 is movably disposed within the middle chamber 112 of the casting 10 and comprises a slider 21, a first roller 22 and a second roller 23, wherein the slider 21 has an upper plate 211, a lower plate 212 opposite to the upper plate 211, a side plate 213 coupling to the upper plate 211 and the lower plate 212 and a space 214 formed between the upper plate 211 and the lower plate 212. In this embodiment, the side plate 213 has an oil drain hole 213a, the first roller 22 is movably disposed within the space 214, besides, the upper plate 211 and the lower plate 212 have an open hole 211a, 212a formed thereon respectively and which are corresponding to each other. Each of the open holes 211 a, 212a corresponds to the shaft hole 12 of the casting 10, the first roller 22 corresponds to each of the open holes 211 a, 212a and the second roller 23 is fixed within the space 214 and adjacent to the side plate 213 of the slider 21. In this embodiment, the slider 21 further has a through hole 215 formed thereon and penetrating the upper plate 211 and the lower plate 212, the second roller 23 corresponds to the through hole 215. Furthermore, the sliding assembly 20 further comprises a second fixing unit 25 and an E shaped ring 26, wherein the second fixing unit 25 is inserted into the through hole 215 of the slider 21 and penetrates the second roller 23 so as to fix the second roller 23 into the space 214 of the slider 21. The E shaped ring 26 is fastened to one end of the second fixing unit 25 thereby preventing the second fixing unit 25 from slipping.

[0009] With reference again to Fig.1 and Fig.3, the drive assembly 30 comprises a shaft 31, an eccentric cam 32 coupled to the shaft 31 and a shaft cap 33. The shaft 31 is pivotally disposed within the shaft hole 12 of the casting 10 and inserted into the open holes 211a, 212a of the upper plate 211 and the lower plate 212 respectively, and preferably the shaft 31 is integrally formed with the eccentric cam 32 for enhancing structural strength of the shaft 31. The eccentric cam 32 is located within the space 214 of the slider 21 and contacts against the first roller 22 and the second roller 23 of the sliding assembly 20. The shaft cap 33 is disposed on the shaft 31 and tightly covers the shaft hole 12 of the casting 10. In this embodiment, the shaft 31 is coupled to the shaft hole 12 of the casting 10 by means of the shaft cap 33 and one end of the shaft 31 protrudes from the shaft cap 33 so as to couple a linking rod unit not shown in the drawings which is fixed on a door or a door frame. When the door is opened or closed, the linking rod unit drives the shaft 31 of the drive assembly 30 to rotate and the eccentric cam 32 rotates accompanying to the shaft 31, and then the rotating eccentric cam 32 pushes the first roller 22 and the second roller 23 which contact against the eccentric cam 32, when the eccentric cam 32 pushes

the second roller 23, the slider 21 will be moved from the middle chamber 112 to the front chamber 111. In this invention, the second roller 23 is fixed to the slider 21 via the second fixing unit 25 so that the slider 21 can be moved with the second roller 23 while the eccentric cam 32 pushes the second roller 23.

[0010] With reference again to Fig.1 and Fig.3, the piston assembly 40 is disposed and movable within the rear chamber 113 of the casting 10 and comprises a tube shaped piston 41 and a relief valve assembly 42 disposed within the tube shaped piston 41. The tube shaped piston 41 has an outside wall 41 a, a first end portion 411 coupled to the first roller 22, a second end portion 412 opposite to the first end portion 411, an axial oil passage 413 in communication with the first end portion 411 and the second end portion 412 and a transverse oil passage 414 in communication with the outside wall 41a and the axial oil passage 413. In this embodiment, the first end portion 411 has an upper protruding plate 411a, a lower protruding plate 411b opposite to the upper protruding plate 411a and a connecting hole 411c penetrating the upper protruding plate 411 a and the lower protruding plate 411b. The first roller 22 is located between the upper protruding plate 411a and the lower protruding plate 411b and corresponds to the connecting hole 411c. Besides, the upper protruding plate 411a and the lower protruding plate 411b are inserted into and axially movable within the open hole 211a of the upper plate 211 and the open hole 212a of the lower plate 212 respectively in this embodiment. In this embodiment, the sliding assembly 20 may further comprise a first fixing unit 24 for coupling the first end portion 411 of the tube shaped piston 41 to the first roller 22, wherein the first fixing unit 24 is inserted into the connecting hole 411 c of the first end portion 411 and penetrates the first roller 22, so that the first end portion 411 can be coupled to the first roller 22 via the first fixing unit 24 and the tube shaped piston 41 will be moved within the rear chamber 113 while the eccentric cam 32 pushes the first roller 22. In addition, the transverse oil passage 414 movably corresponds to the first outlet 15b or the second outlet 15c of the second oil passage 15. With reference again to Fig.1 and Fig.3, the relief valve assembly 42 disposed within the axial oil passage 413 of the tube shaped piston 41 comprises a valve carrier 421, a valve holder 422 inserted into the valve carrier 421 and a relief valve 423 disposed within the valve holder 422. In this embodiment, the valve holder 422 has an oil drain passage 422a and the relief valve 423 disposed within the oil drain passage 422a will close the oil drain passage 422a under normal operation. Besides, it further comprises a filter 43 disposed at one end of the valve carrier 421 in this embodiment applied for filtering impurity contained in the hydraulic oil and preventing impurity from entering the oil drain passage 422a to cause obstruction unable to function normally.

[0011] With reference again to Fig.1 and Fig.3, the elastic assembly 50 is disposed within the front chamber 111 of the casting 10 and contacts against the slider 21

of the sliding assembly 20. In this embodiment, the elastic assembly 50 is capable of adjusting opening/closing force with respect to the automatic door closer, which comprises a first resilient member 51 located at one side of the slider 21, a second resilient member 52 inserted into the first resilient member 51, an adjusting unit 53, a spring end cap 54 disposed at one end of the second resilient member 52, a rejecting unit 55 contacting against the side plate 213 of the slider 21, a third check valve 56 disposed within the rejecting unit 55, a stopper 57 able to limit the third check valve 56 and an oil ring 58 disposed around the rejecting unit 55. The first resilient member 51 has a first end 51a and a second end 51b contacted against the rejecting unit 55. The rejecting unit 55 is disposed and movable within the front chamber 111 of the casting 10 and has a surface 55a facing the first resilient member 51, a protruding pole 55b formed on the surface 55a, an outer wall 55c and an oil return passage 55d corresponding to the oil drain hole 213a. Or, the rejecting unit 55 is integrally formed with the side plate 213 of the slider 21 in another embodiment. One end of the second resilient member 52 is disposed on the protruding pole 55b of the rejecting unit 55 and contacts against the surface 55a of the rejecting unit 55. The adjusting unit 53 is disposed at one end of the front chamber 111 and coupled to the first end 51a of the first resilient member 51, and the spring end cap 54 is disposed between the adjusting unit 53 and the second resilient member 52. In this embodiment, the adjusting unit 53 comprises an adjusting screw 531 and an adjusting screw cap 532 coupled to the adjusting screw 531, the spring end cap 54 is disposed between the adjusting screw cap 532 of the adjusting unit 53 and the second resilient member 52, and the adjusting screw cap 532 contacts against the spring end cap 54. In this embodiment, The first resilient member 51 and the second resilient member 52 are utilized for pressuring the rejecting unit 55, and the adjusting screw 531 may adjust compressing force of not only the adjusting screw cap 532 against the first resilient member 51 but also the spring end cap 54 against the second resilient member 52 by pushing the spring end cap 54, thereby further achieving the efficiency of adjusting opening/closing force of the automatic door closer. Besides, when the slider 21 moves toward the front chamber 111, it compresses the first resilient member 51 and the second resilient member 52 by pushing the rejecting unit 55, contrarily, the first resilient member 51 and the second resilient member 52 may also allow the slider 21 to restore by pushing the rejecting unit 55. In addition, with reference again to Fig.1 and Fig.3, the third check valve 56 is disposed within the oil return passage 55d of the rejecting unit 55 and the stopper 57 penetrates the protruding pole 55b and the oil return passage 55d of the rejecting unit 55 to limit the third check valve 56 within the oil return passage 55d. The oil ring 58 is disposed around the outer wall 55c of the rejecting unit 55 capable of preventing the hydraulic oil from flowing between the outer wall 55c of the rejecting unit 55 and a front chamber

wall 111a of the front chamber 111. Besides, the pair of lid 60 seal the two ends of the casting 10 respectively to prevent the hydraulic oil from leaking.

[0012] The operating method of the automatic door closer will be described as follows by referring to Fig.4A, Fig.4B, Fig.5, Fig.6A and Fig.6B. Initially, with reference to Fig.4A and Fig.6A, when a door is opened by an exterior force, the eccentric cam 32 rotates to push the second roller 23 and drive the slider 21 moving toward the front chamber 111. Meantime, the slider 21 will push the rejecting unit 55 to compress the first resilient member 51 and the second resilient member 52. When the rejecting unit 55 makes a movement, the hydraulic oil inside the front chamber 111 flows into the oil inlet 13a of the first oil passage 13 to produce a hydraulic oil pressure inside the first oil passage 13 capable of making the first check valve 14 open. Next, the hydraulic oil will flow from the oil outlet 13b of the first oil passage 13 into the rear chamber 113 and push the tube shaped piston 41 to move toward the middle chamber 112. Contrarily, with referring to Fig.4B and Fig.6B, when the exterior force is released, both the first resilient member 51 and the second resilient member 52 push the rejecting unit 55 and the slider 21 and enable the eccentric cam 32 to rotate. Rotation of the eccentric cam 32 will push the first roller 22 and drive the tube shaped piston 41 to move toward the lid 60. Meantime, the hydraulic oil inside the rear chamber 113 is pushed by the tube shaped piston 41 to flow into the inlet 15a of the second oil passage 15 to produce a hydraulic oil pressure inside the second oil passage 15 capable of making the second check valve 16 open. Next, the hydraulic oil will flow from the first outlet 15b and the second outlet 15c of the second oil passage 15 into the transverse oil passage 414 and the axial oil passage 413 of the tube shaped piston 41 and through the middle chamber 112, the oil drain hole 213a of the side plate 213 of the slider 21 and the oil return passage 55d of the rejecting unit 55 in order, and finally flow back to the front chamber 111 to close the door. In this embodiment, the hydraulic oil first flows from the first outlet 15b of the second oil passage 15 into the transverse oil passage 414 and the axial oil passage 413 of the tube shaped piston 41 and following the tube shaped piston 41 moves gradually toward the lid 60, which makes the first outlet 15b of the second oil passage 15 close. Meantime, the hydraulic oil changes to flow from the second outlet 15c of the second oil passage 15 into the transverse oil passage 414 and the axial oil passage 413 of the tube shaped piston 41. Furthermore, when the hydraulic oil flows into the oil return passage 55d of the rejecting unit 55, the third check valve 56 will open allowing the hydraulic oil to flow smoothly back to the front chamber 111. Moreover, with reference to Fig.7, it is for designation that there is a maximum interval X between the surface 55a of the rejecting unit 55 and the oil inlet 13a of the first oil passage 13, the eccentric cam 32 has a rotation center O, a maximum radius R1 and a minimum radius R2, the maximum interval X must be greater than

a difference Y of the maximum radius R1 and the minimum radius R2 $X > Y$ so as to prevent the rejecting unit 55 from obstructing motion of oil passage when rejecting unit 55 moves in this embodiment.

[0013] In addition, the hydraulic oil flows slowly back to the front chamber 111 during door-closing process, if the door is suddenly hit by an exterior force such as kicking the door during door-closing process, the door closer might cause damage because it is too late for the hydraulic oil to flow back. In order to solve this problem mentioned above, with reference again to Fig.4B and Fig. 6B, the relief valve 423 of the relief valve assembly 42 applied in this embodiment will open quickly when the door is suddenly hit by an exterior force during door-closing process to make the hydraulic oil located at the rear chamber 113 flow directly into the oil drain passage 422a of the valve holder 422 and through the middle chamber 112, the oil drain hole 213a of the side plate 213 of the slider 21 and the oil return passage 55d of the rejecting unit 55 in order, and finally flow quickly back to the front chamber 111. Accordingly, the hydraulic oil can flow quickly back as to prevent the door closer from damaging as well as operating smooth of automatic door closer can be improved via reciprocation of the slider 21 and the tube shaped piston 41 and action of the first oil passage 13 and the second oil passage 15 according to the present invention.

[0014] While the present invention has been particularly illustrated and described in detail with respect to the preferred embodiments thereof, it will be clearly understood by those skilled in the art that various changed in form and details may be made without departing from the spirit and scope of the present invention.

Claims

1. An automatic door closer comprising:

a casting (10) having a front chamber (111), a rear chamber (113), a middle chamber (112) in communication with the front chamber (111) and the rear chamber (113), a shaft hole (12) penetrating the middle chamber (112) and a first oil passage (13), the first oil passage (13) having an oil inlet (13a) in communication with the front chamber (111) and an oil outlet (13b) in communication with the rear chamber (113);
 a sliding assembly (20) disposed within the middle chamber (112) of the casting (10) comprising a slider (21) disposed between the oil inlet (13a) and the oil outlet (13b), a first roller (22) and a second roller (23) disposed within the slider (21) respectively;
 a drive assembly (30) comprising a shaft (31) and an eccentric cam (32) coupled to the shaft (31), wherein the shaft (31) is pivotally disposed within the shaft hole (12), the eccentric cam (32)

is located within the slider (21) and contacts against the first and second rollers (22, 23);
 a tube shaped piston (41) disposed within the rear chamber (113) of the casting (10) having a first end portion (411) and a second end portion (412) opposite to the first end portion (411), the first end portion (411) connecting with the first roller (22); and
 a first resilient member (51) disposed within the front chamber (111) of the casting (10).

2. The automatic door closer in accordance with claim 1, further comprising a first check valve (14) located within the first oil passage (13) and disposed adjacent to the oil outlet (13b) of the first oil passage (13).
3. The automatic door closer in accordance with claim 1, wherein it further has a second oil passage (15) disposed within the casting (10), the second oil passage (15) has an inlet (15a), a first outlet (15b) and a second outlet (15c) in communication with the rear chamber (113) respectively.
4. The automatic door closer in accordance with claim 3, further comprising a second check valve (16) located within the second oil passage (15) and disposed adjacent to the inlet (15a) of the second oil passage (15).
5. The automatic door closer in accordance with claim 3, wherein the tube shaped piston (41) has an outside wall (41a), an axial oil passage (413) in communication with the first and second end portions (411, 412) and a transverse oil passage (414) in communication with the outside wall (41a) and the axial oil passage (413), the transverse oil passage (414) of the tube shaped piston (41) movably corresponds to the first outlet (15b) or the second outlet (15c) of the second oil passage (15).
6. The automatic door closer in accordance with claim 1, wherein the slider (21) has an upper plate (211), a lower plate (212) opposite to the upper plate (211), a side plate (213) coupling to the upper plate (211) and the lower plate (212) and a space (214) formed between the upper plate (211) and the lower plate (212), the first roller (22) is movably disposed within the space (214), the second roller (23) is fixed within the space (214).
7. The automatic door closer in accordance with claim 6, wherein the upper plate (211) and the lower plate (212) of the slider (21) have an open hole (211a, 212a) formed thereon respectively and which are corresponding to each other, each of the open holes (211a, 212a) corresponds to the shaft hole (12) of the casting (10), the first roller (22) corresponds to each of the open holes (211 a, 212a).

8. The automatic door closer in accordance with claim 6, wherein the second roller (23) is adjacent to the side plate (213) of the slider (21).
9. The automatic door closer in accordance with claim 1, further comprising a relief valve assembly (42) which is disposed within the tube shaped piston (41) and comprises a valve carrier (421), a valve holder (422) inserted into the valve carrier (421) and a relief valve (423) disposed within the valve holder (422). 5
10
10. The automatic door closer in accordance with claim 9, wherein the valve holder (422) of the relief valve assembly (42) has an oil drain passage (422a) and the relief valve (423) is disposed within the oil drain passage (422a). 15
11. The automatic door closer in accordance with claim 1, further comprising a rejecting unit (55) disposed between the slider (21) and the first resilient member (51) and contacting against the slider (21). 20
12. The automatic door closer in accordance with claim 11, wherein the rejecting unit (55) has a surface (55a) facing the first resilient member (51), there is a maximum interval (X) between the surface (55a) and the oil inlet (13a) of the first oil passage (13), the eccentric cam (32) has a rotation center (O), a maximum radius (R1) and a minimum radius (R2), the maximum interval (X) is greater than a difference (Y) of the maximum radius (R1) and the minimum radius (R2). 25
30
13. The automatic door closer in accordance with claim 11, wherein the slider (21) has a side plate (213), the side plate (213) has an oil drain hole (213a), the rejecting unit (55) has an oil return passage (55d) corresponding to the oil drain hole (213a). 35
14. The automatic door closer in accordance with claim 11, further comprising a second resilient member (52) inserted into the first resilient member (51) and contacting against the rejecting unit (55). 40

45

50

55

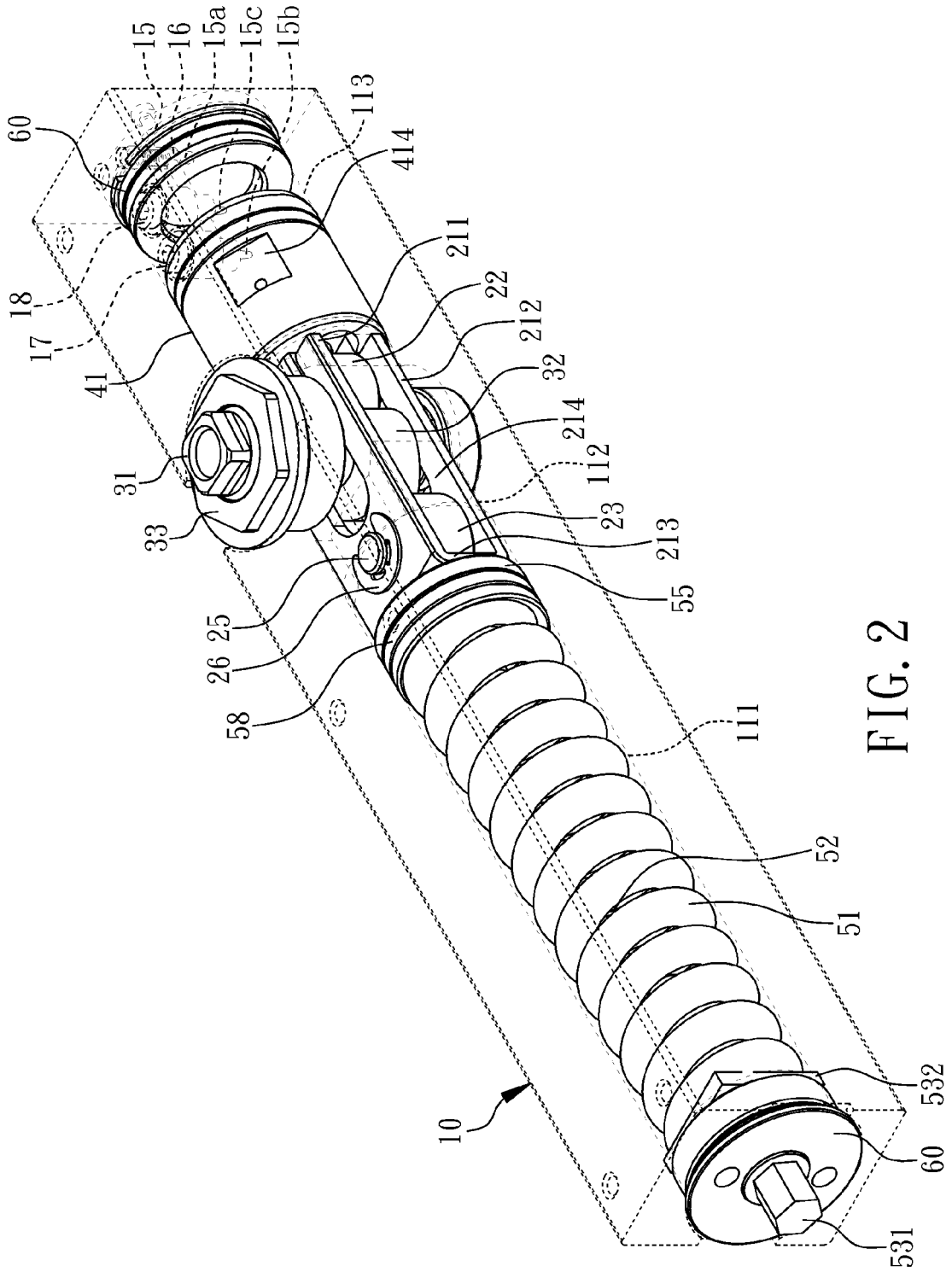

FIG. 2

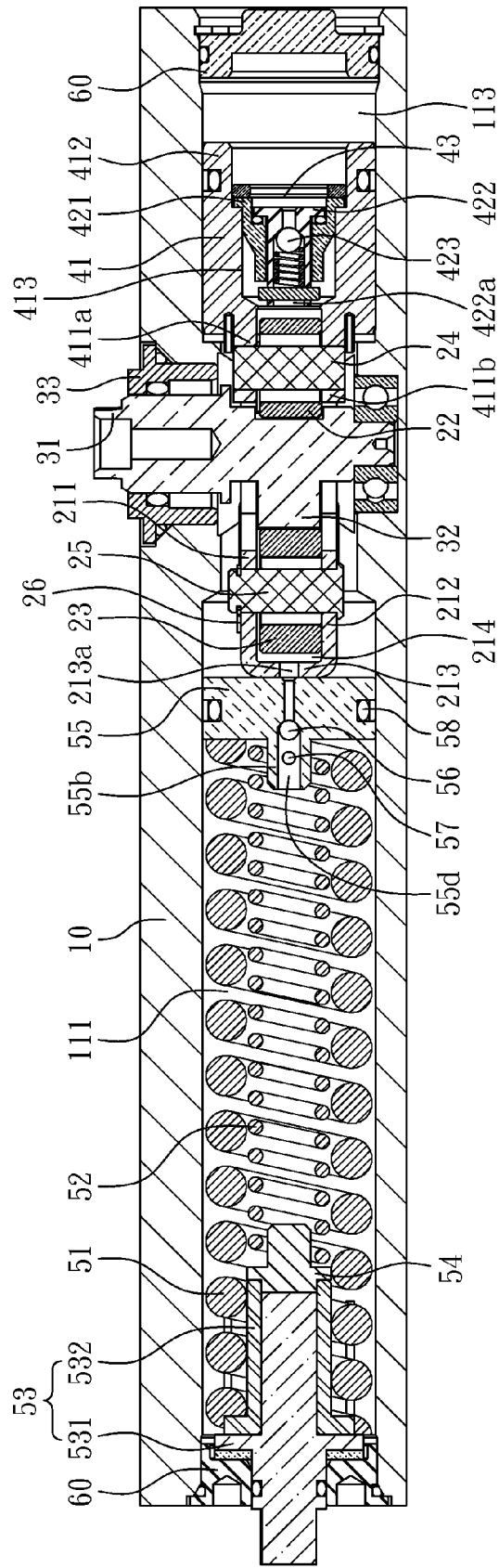

FIG. 3

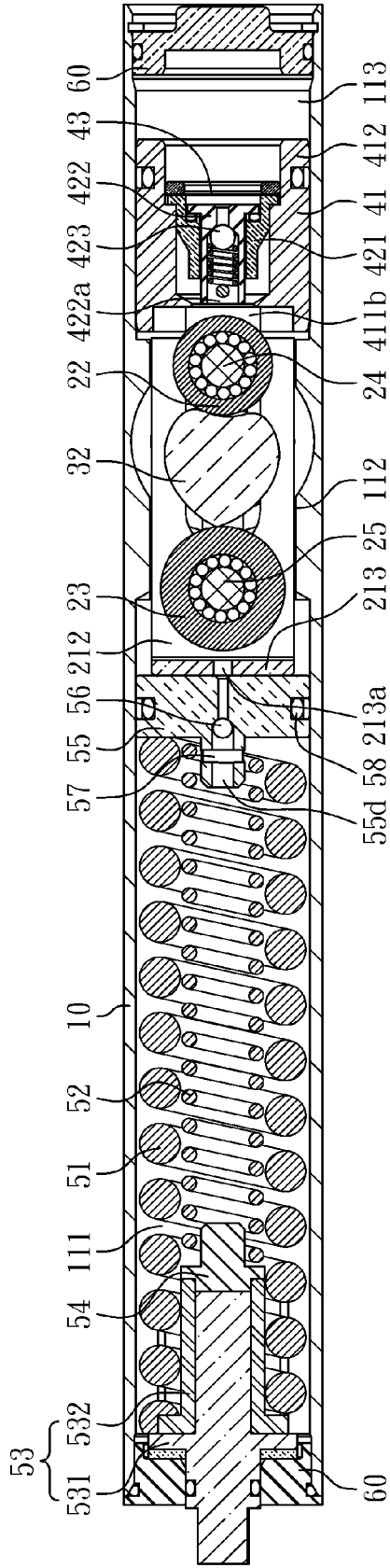

FIG. 4A

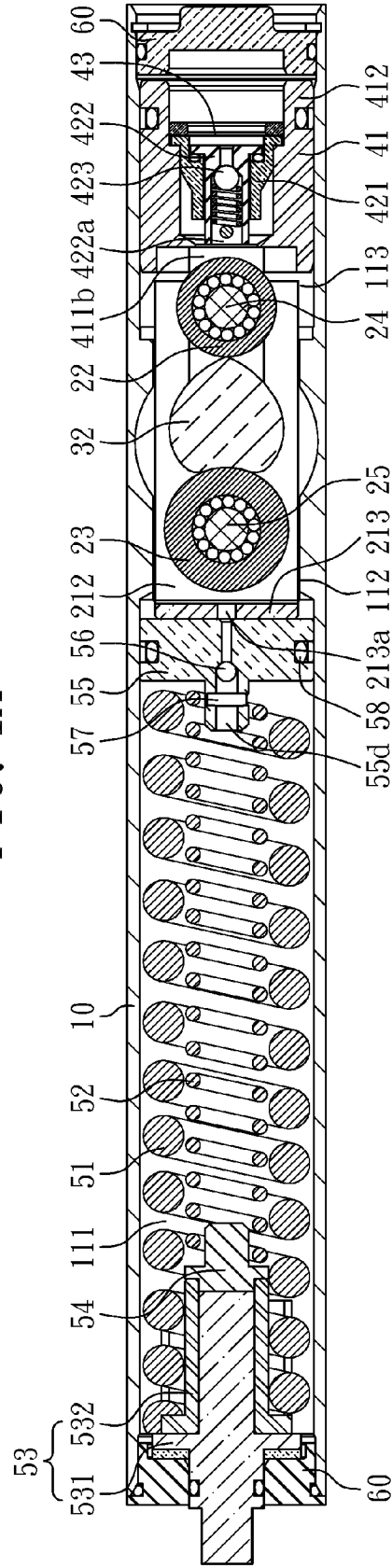

FIG. 4B

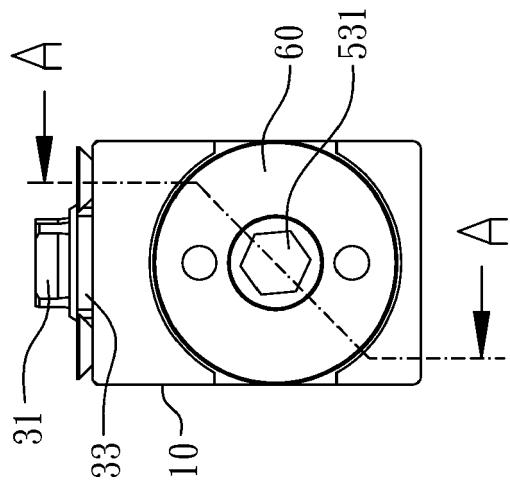

FIG. 5

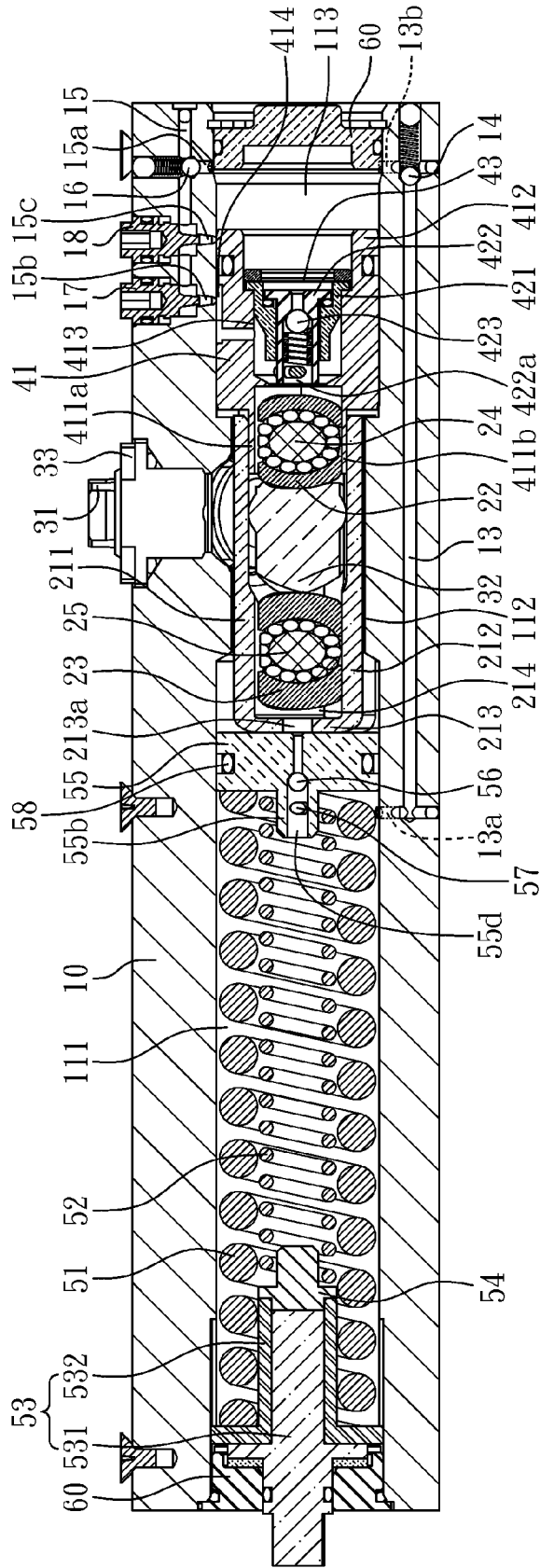

FIG. 6A

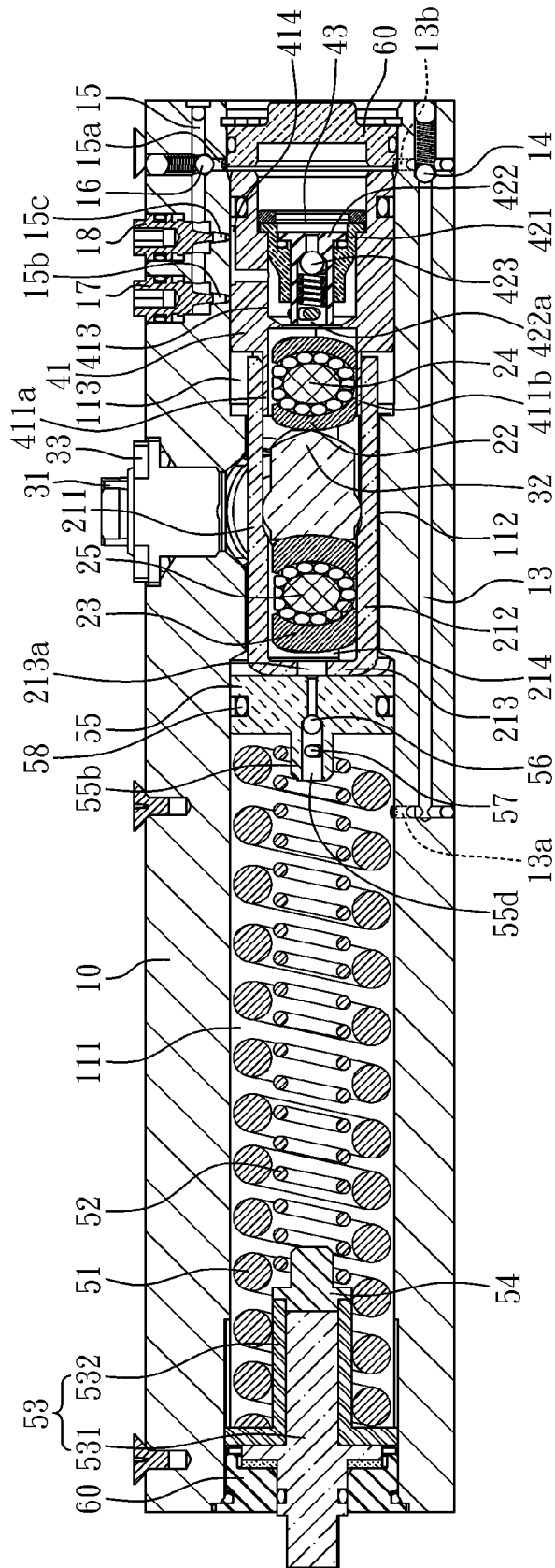

FIG. 6B

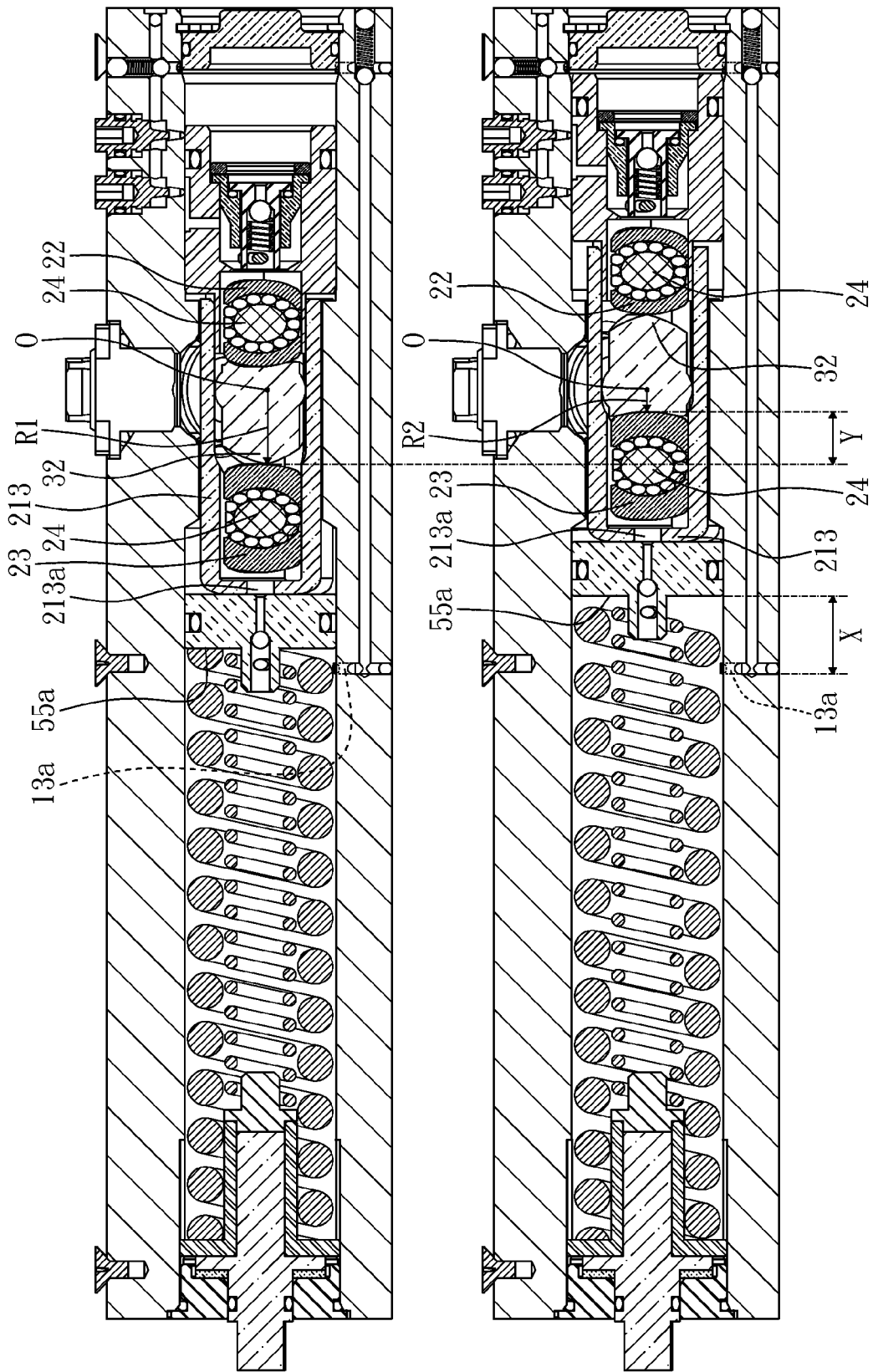

FIG. 7

REFERENCES CITED IN THE DESCRIPTION

This list of references cited by the applicant is for the reader's convenience only. It does not form part of the European patent document. Even though great care has been taken in compiling the references, errors or omissions cannot be excluded and the EPO disclaims all liability in this regard.

Patent documents cited in the description

- TW 428658 [0002]