



PATENT SPECIFICATION

(11) S83286

(21) Application No. S2002/0607

(22) Date of Filing of Application: 22/07/2002

(45) Specification Published: 11 February 2004

(51) Int. Cl.7 A47J 31/18 , A45F 3/16

(54) Title: Beverage brewing device

(72) Inventor: RIAD HOSEIN

(73) Patent Granted to: RIAD HOSEIN, British, 7 Woodstown Close, Knocklyon, Dublin 16,
Ireland

8020001
S83286

Title

Beverage brewing device

5 **Field of the Invention**

The present invention relates to brewing devices for use with beverages such as tea or coffee and which can be used to brew the tea or coffee in a controlled fashion, and which may be disposable.

10

Background to the Invention

Generally when making a cup of tea or coffee outside the home or away from “kitchen-type” facilities, it is difficult to make a satisfactory cup of tea or coffee. If making a cup of tea using a disposable cup and teabag, the user must remove and dispose of the teabag after brewing. This can be awkward, especially when travelling, for a number of reasons. Firstly, one is rarely provided with a spoon or other utensil suitable for lifting the teabag out of a cup of boiling liquid. The teabag then drips boiling water as it is being removed, which is messy, and finally, it can frequently be difficult to find a litter bin in which to dispose of the teabag. With a cup of freshly brewed coffee, one does not have the problem of attempting to dispose of the teabag, but one has the problem of the coffee grounds being present at the bottom of the cup, which is both unpleasant to drink and which means that the coffee can continue to brew and become extremely strong. The alternative is to use instant coffee which does not have the same flavour.

25

There have been various attempts in the art to overcome these problems. One of these is known from U.S. Patent No. 2,743,664 which discloses a disposable coffee brewer. Essentially, the brewer comprises a pair of nestable, disposable cups, the base of one cup comprising a chamber which can receive a charge of coffee, the base of the chamber comprising a filter material. To use the device, one cup is placed on top of the other and boiling water is poured into the top cup. As the boiling water passes through

30

the chamber of coffee and filter paper, it drips brewed coffee into the cup below. As mentioned above, the disadvantage of this arrangement is that one has to dispose of the dripping upper cup once the coffee is brewed.

5 Another attempt to overcome the problem is provided by U.S. Patent No. 6,038,963 which provides two cups, one nestable within the other. The tea or coffee grounds are placed in the base of one cup and hot water is added. The second cup has a filter which extends across the open bottom end of the cup, so that when the second cup is placed inside the first, the material being brewed is separated from the liquid which
10 flows through the filter and into the second cup. The problem with this device is that the hot water is still in contact with tea leaves or with the coffee grounds and so the beverage can continue to brew. For many people this is a disadvantage, since they wish to brew their beverage to a particular strength and wish to drink it at that strength, rather than have the beverage become stronger with time. Even if one were to use this device
15 with the tea or coffee in the inner cup which is simply lifted out of the outer cup by the user, there is still the problem of disposing of the inner cup which is dripping hot liquid.

Objects of the Invention

20 It is therefore an object of the invention to provide a beverage brewing device which allows the user to determine when the brewing process is to start and when it is to stop, in order to produce a beverage which is brewed to the strength which is satisfactory to the drinker. It is a further object to provide a beverage brewing device, such as a disposable cup, which avoids the need to remove a teabag or a filter chamber
25 from the cup after brewing, and thus does away with the need to dispose of a teabag or a filter cup. It is a further object to provide a device which allows a second cup of tea or coffee to be brewed from the same tea leaves or coffee grounds. It is a further object to provide a disposable cup which provides a good quality brew of tea, by preventing the user from using a spoon to squeeze a teabag in the cup to speed up the brewing, or to
30 squeeze the bag as it is being removed from the cup to remove excess water, since both of these actions can lead to a bitter cup of tea. It is another object to provide a brewing

device which could be used for any beverage which can be supplied in powder or granulate form, such as soups or powdered milk.

Summary of the Invention

5

According to the present invention there is provided a beverage brewing device comprising an outer cup having a base and a circumferential side wall formed integrally with the base and extending therefrom, and an inner cup having a base and a circumferential side wall formed integrally with the base and extending therefrom, the inner cup being dimensioned so that it can fit within the outer cup, the device being provided with at least one chamber adapted to retain a charge of beverage brewing material, the chamber having at least one port for communication with an internal volume of the device, and the other cup being provided with a perforate area, the perforate area being moveable between a position in which it overlies the communication port of the chamber and a position in which it is not aligned with the communication port.

10
15

Preferably, one cup is found with indented regions in the side wall so that when the two cups are nested together, the side wall of the other cup closes or seals the indented region to define the chamber.

20

Preferably one cup is provided with at least one protrusion in the side wall which projects into the internal volume, which defines the chamber when the device is assembled. Preferably, the cup is provided with two such protrusions so that the device may be provided with two chambers. It will be apparent, however, that the device could be provided with a plurality of such protrusions and chambers.

25

Suitably where the first cup is provided with two chambers the other cup is provided with two perforate areas on its side wall. If more than two chambers are provided then more than two perforate areas may be provided.

30

In a particularly preferred embodiment the outer cup is provided with a pair of indented regions and the inner cup is provided with a pair of perforate areas to define a pair of chambers. Suitably the pairs of indented regions are provided on opposite sides of the cups.

5

The perforate areas may comprise a single aperture or a plurality of apertures, the apertures being of sufficient size to allow free movement of water into and out of the chamber, but small enough to prevent the leaves, coffee grounds or the like from leaking from the chamber and into the internal volume of the cup.

10

In an alternative embodiment the device may be provided with a discrete chamber which is configured to fit into the outer cup and to rest in a base portion thereof, and which has at least one communication port on the surface thereof which in use does not abut the cup base, the inner cup having at least one aperture which can be positioned to align with the communication port in the chamber. Suitably the chamber has a plurality of communication ports and the base of the inner cup has a plurality of apertures. The apertures may be very small or a larger aperture may be provided which is covered with a fether or mesh to retain the tea leaves etc. in the chamber.

15

20

In a further embodiment, the inner and outer cups are formed with upstands on their bases which extend into the internal volume of each cup. One upstand may be provided with an indented region and the other upstand may be provided with the perforate area, such that on assembly of the cups together, a chamber is created.

25

The beverage brewing device may be made of any of a variety of materials such as paper, plastics material, or paper reinforced with a plastics material and the like.

30

Brief Description of the Drawings

The invention will now be described in greater detail with reference to the accompanying drawings in which:

5 Figure 1 is a perspective view of a first embodiment of a brewing device in accordance with the invention, showing the chamber and the inner cup being fitted into the outer cup

Figure 2 shows the device shown in Figure 1, with the chamber in position,

Figure 3 is a view from the top showing the two cup portions of the embodiment of

10 Figures 1 and 2 in the process of being rotated,

Figure 4 is an alternative embodiment of a device in accordance with the invention,

Figure 5 is an alternative embodiment of a device in accordance with the invention, and

Figure 6 is shows the device with the cups separated from one another.

Figure 7 is a cut-away of the device of Figure 5.

15

Detailed Description of the Drawings

As shown in Figure 1, the cup assembly comprises a first inner cup (1) and a second outer cup (2), the inner cup (1) being tightly nestable within the outer cup (2).

20 The inner cup (1) has a plurality of perforations (3) in its base (4). The assembly also comprises a discrete chamber or container (5) which is adapted to fit into the bottom of the outer cup (2) and which has a plurality of perforations (6) on the surface (7) which is uppermost when the container is placed in the cup (2). In use, this container (5) can be filled prior to use with loose tea leaves, teabags or with ground coffee. As shown in

25 Figure 2, to use the brewing device, a container (5) is placed at the bottom of the outer cup (2). The inner cup (1) is then inserted into the outer cup (2) so that the perforations (3 and 6) are aligned and boiling water is then poured into the cup. There is therefore free passage of water into the container (5) to brew the tea or coffee and movement of that water out into the inner cup (1).

30 When the inner cup is inserted into the outer cup, the two cups are locked together at the rim so that they are free to turn relative to each other, but cannot be pulled apart. Both the inner and outer cups are provided on their upper edges with a lip,

the lips being dimensioned so that the lip of the inner cup (1) can rest on the rim of the outer cup (2). The lip of the inner cup (1) fits over the rim of the outer cup (2) when the device is assembled, so that the two cups are locked securely together. The overhanging rim of the inner cup has a groove over its entire length that locks against the rim of the outer cup. This is a safety mechanism to ensure that the two cups do not separate when the user is drinking. It also serves as a barrier to prevent liquid travelling up between the cups and leaking out, and also to ensure that when one cup is being rotated relative to the other, the two cups move in only one plane and so do not twist apart.

The brewing process can be accelerated and generally improved by swirling the cup or stirring the cup contents, which serves to draw out the brewed beverage from the container or chamber (5). Once the user has determined that the tea or coffee is of a strength to their liking, the inner cup (1) is rotated relative to the outer cup (2), so that the perforations (3) in the base (4) of the inner cup (1) no longer overlie the perforations (6) on the top surface (7) of the container (5). This is shown in greater detail in Figure 3 in which the perforations (3 and 6) are shown partially aligned. When the inner cup (1) is rotated sufficiently far so that there is a complete mis-alignment of the perforations (3 and 6), no further brewing of the tea or coffee can take place. The user is then free to drink the beverage without its strength being altered.

When the two cups (1 and 2) are assembled together they form a tight fit, so that the pocket or chamber (5) can be securely closed off from the water when the cups are rotated relative to each other.

In the alternative embodiment shown in Figure 4, the brewing device also comprises an inner (1) and an outer cup (2). The base (8) of the outer cup (2) is provided with an upstand (9) which extends into the volume (10) of the cup (2). In this particular embodiment, the upstand (9) is frustoconical in shape and is formed with a pair of protruding sections on its outer surface which define a pair of indented channels (11). The base (4) surface of the inner cup (1) is formed with a complementary upstand (12), such that when the inner cup (1) is positioned inside the outer cup (2), the two upstands (9 and 12) are aligned, with the upstand (12) of the inner cup (1) surrounding the upstand (9) of the outer cup (2). The upstand (9) is shorter than the upstand (12) so

that when the cups are nested together, the upper flat surfaces (14) of both upstands make contact and the bases (4 and 8) also make contact. The upstand (12) of the inner cup (1) is provided with a number of perforations (13) which can be aligned with the indented channel (11) in the upstand (9) of the outer cup (2). In that position, brewing
5 of tea or coffee can take place. When the user is satisfied with the strength of the beverage, the inner cup (1) can be rotated relative to the outer cup (2) to stop the brew.

The protrusions are hollow so that one assembled cup can be placed inside another assembled cup, with the outside surface of the protrusions of one cup in contact with the inner surface of the protrusions of the second cup.

10

Another embodiment of the cup assembly is shown in Figure 5, which also comprises an outer cup (2) and an inner cup (1). Both the inner and outer cups are provided on their upper edges with a lip (15), the lips (15) being dimensioned so that the lip of the inner cup (1) can rest on the rim (17) of the outer cup (2). The lip (15) of the
15 inner cup (1) fits over the rim (17) of the outer cup (2) when the device is assembled, so that the two cups are locked securely together.

20

The overhanging rim of the inner cup has a groove over its entire length that locks against the rim of the outer cup. This is a safety mechanism to ensure that the two cups do not separate when the user is drinking. It also serves as a secondary barrier to prevent liquid travelling up between the cups and leaking out, and also to ensure that when one cup is being rotated relative the other, the two cups move in only one plane and so do not twist apart.

25

The outer cup (2) is formed with a pair of lateral indented sections (16) along its outer surface which project into the inside of the cup, and can abut the outside wall of the inner cup when the device is assembled. The indented sections (16) extend along the lower region of the outer cup (2) thus defining an internal ledge (18) in the cup. These indented sections (16) serve to define a pair of lateral channels or pockets (19) on
30 the inner side surfaces of the outer cup (2). When assembled together the inner cup closes off the channels or pockets (19) to form the chamber. Figure 6 shows the two cups when separated from one another.

The inner cup (1) is formed with two sections of different diameters, the lower section being narrow enough to fit into the inner cup (1) between the indented sections and the upper section being as wide as the outer cup (2). The two sections of different diameters are joined by a flange (20) which can rest upon the internal ledges (18) of the outer cup (2) when the two cup sections are nested together. The flange (20) of the inner cup (1) thus closes the upper region of the chamber and prevents boiling water travelling up to the rim between the two cups.

The indented regions of the outer cup (2) have the additional advantage that they give the user an improved grip on the cup when the two cups are being twisted relative to each other.

The lower section of the inner cup (1) is provided with two areas of perforations (3), one on either side of the cup, opposite each other. The areas of perforations (3) are sized such that the inner cup (1) can be twisted so that the perforations (3) are aligned with the chambers and then twisted further so that the perforations (3) are aligned with the indented sections and there is no overlap with the chambers. In this way rotation of the inner cup (1) can open and close the chambers to allow water in or to shut off the chamber from the water. This is shown most clearly in Figure 7 which is a cut away view of the lower portion of the cups showing the chamber with the perforations (3) in the closed position.

To use this embodiment, tea leaves, coffee grounds or a teabag are placed in the chambers and the inner cup (1) is placed within the outer cup (2). The tea, etc. could be placed in the chamber during the manufacture but could also be placed there by the user. If the device were made of a durable material such as polypropylene plastic, the device would be suitable for use on picnics and the like, since it could be cleaned after use and then reused.

When the beverage is to be brewed, water is added to the cup with the perforations (3) aligned with the pockets. The water may either be boiling water, or cold

water can be used and the water heated in a microwave oven. The beverage is then allowed to brew for a time determined by the drinker. To stop the brewing process the drinker rotates the inner cup (1) so that the perforations (3) overlie the indented sections and the water supply to the pockets is cut off. The user can then add milk and sugar as
5 desired. The brewed tea or coffee thus remains at the strength the drinker was happy with, and there is no need to remove a wet tea bag since the tea bag is retained in the pocket. Clearly loose tea or coffee grounds are also retained in the pocket and so don't float in the cup. Furthermore it is possible to make a second cup of tea or coffee from the tea or coffee remaining in the pocket, by twisting the inner cup (1) so that the
10 perforations (3) overlie the pocket again and the brewing process can be repeated by adding fresh water. This second brew is successful because the pocket is closed off when milk is added to the cup and so milk fat, which would interfere with the brewing process, never comes into contact with the tea or coffee.

15 The words "comprises/comprising" and the words "having/including" when used herein with reference to the present invention are used to specify the presence of stated features, integers, steps or components but does not preclude the presence or addition of one or more other features, integers, steps, components or groups thereof.

Claims

1. A beverage brewing device comprising an outer cup having a base and a circumferential side wall formed integrally with the base and extending therefrom,
5 and an inner cup having a base and a circumferential side wall formed integrally with the base and extending therefrom, the inner cup being dimensioned so that it can fit within the outer cup, one cup being provided with at least one chamber adapted to retain a charge of beverage brewing material, the chamber having at least one port for communication with an internal volume of the device, and the other cup being
10 provided with a perforate area, the perforate area being moveable between a position in which it overlies the communication port of the chamber and a position in which it is not aligned with the communication port.
2. A beverage brewing device as claimed in claim 1 wherein the perforate area
15 comprises at least one aperture, the aperture being of sufficient size to allow free movement of water into and out of the chamber.
3. A beverage brewing device as claimed in any preceding claim wherein one cup
20 is provided with at least one protrusion in the side wall which projects into the internal volume , which defines a chamber in the side wall of the cup.
4. A beverage brewing device as claimed in claim 1 or 2 wherein the device is
provided with a discrete chamber which is configured to fit into the outer cup and to rest in a base portion thereof, and which has at least one communication port on the
25 surface thereof which in use does not abut the cup base, the inner cup having at least one aperture which can be positioned to align with the communication port in the chamber.
5. A beverage brewing device substantially as described herein with reference to
30 any one of the accompanying drawings.

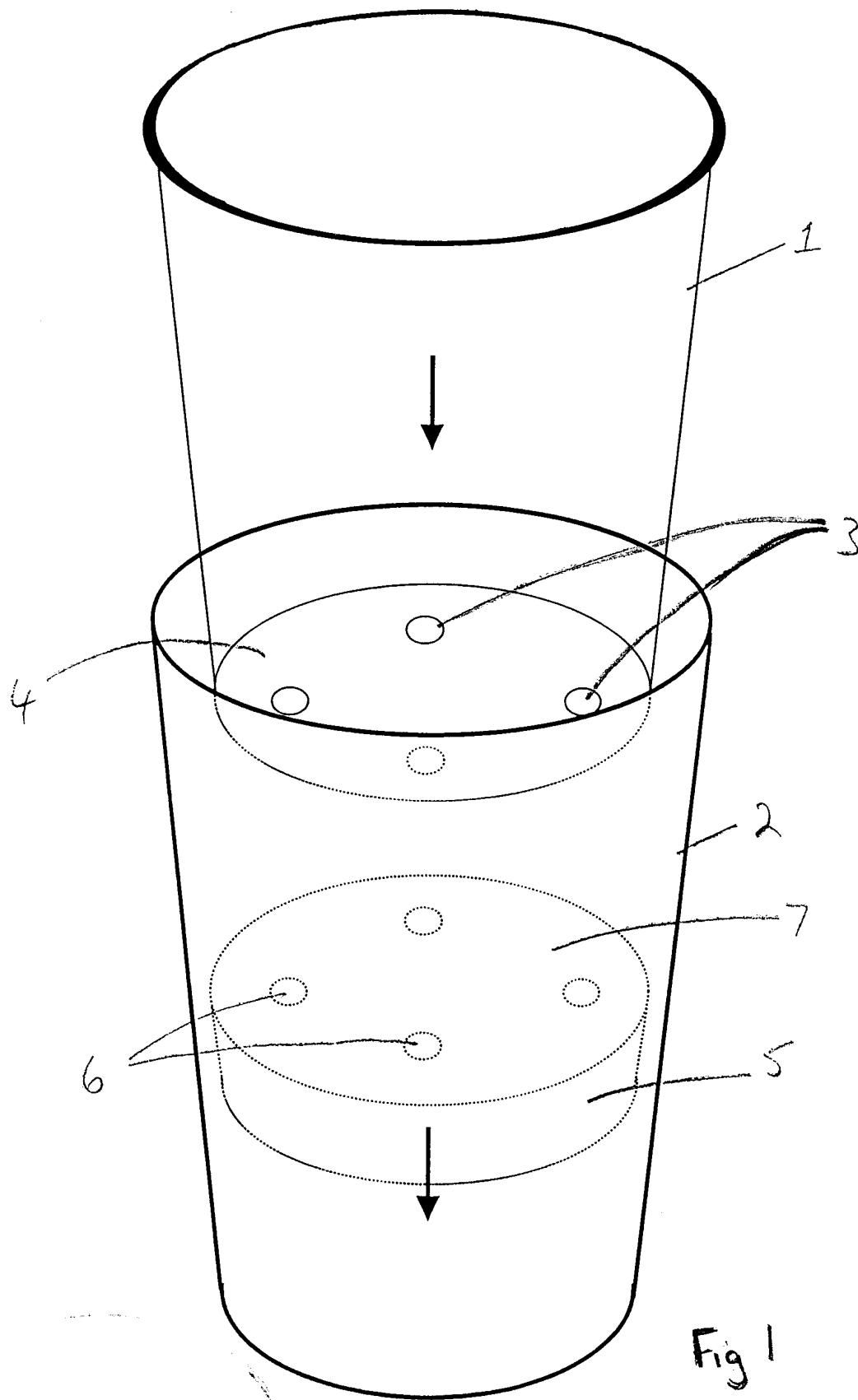

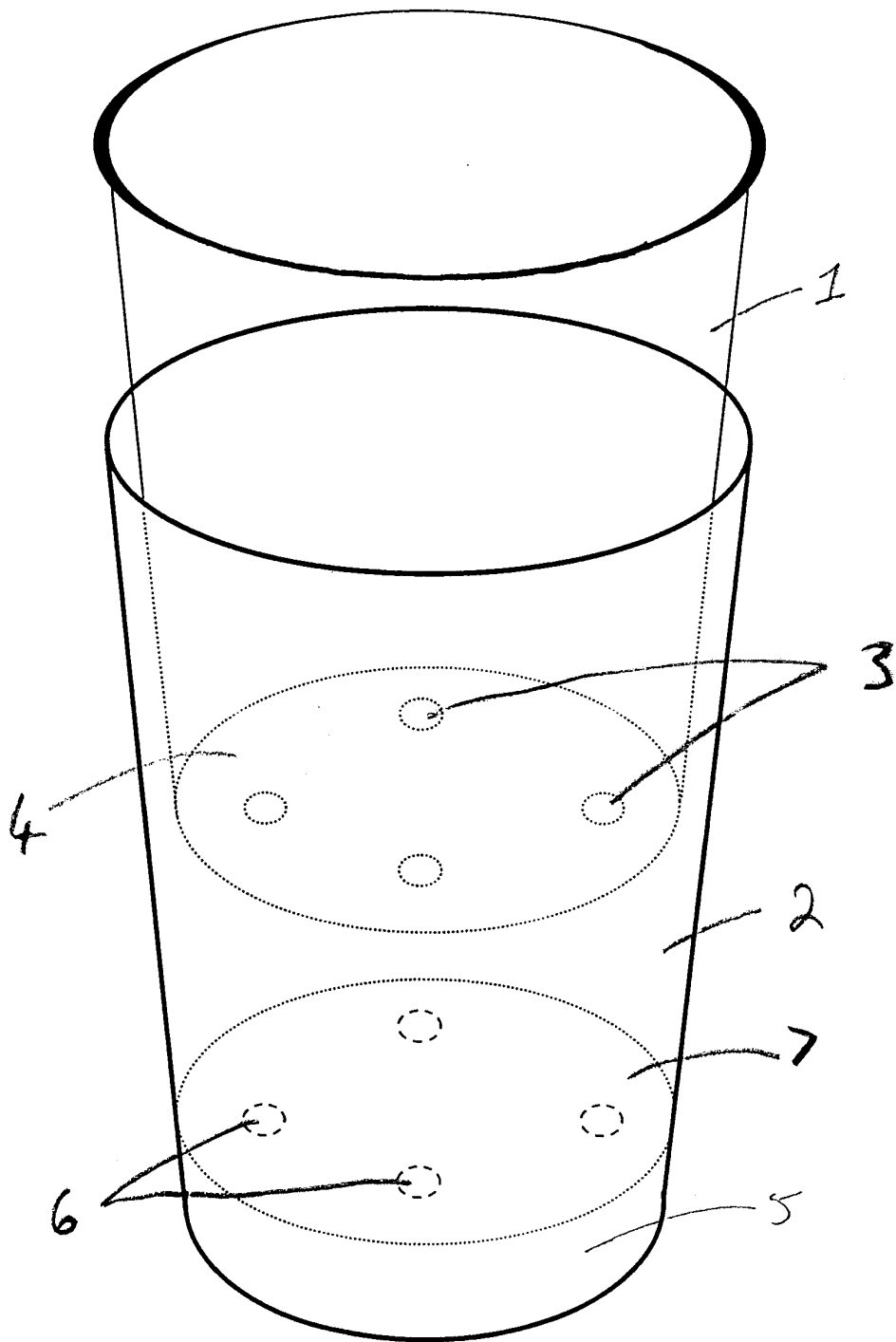

Fig 2

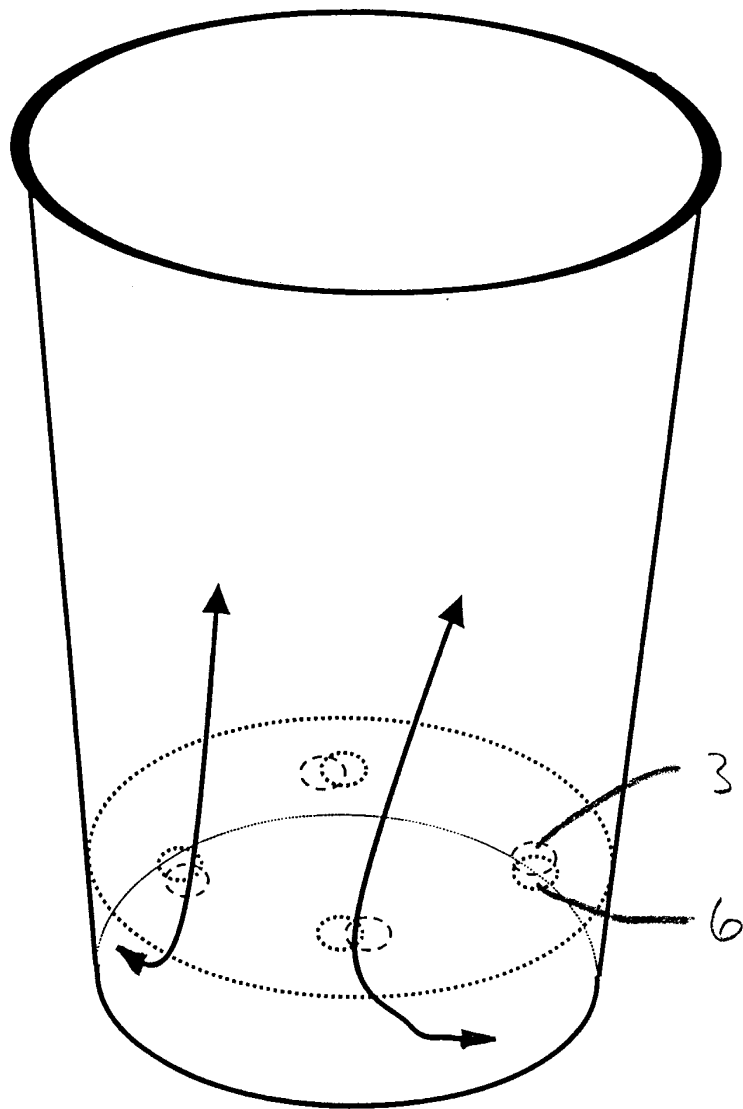

Fig 3

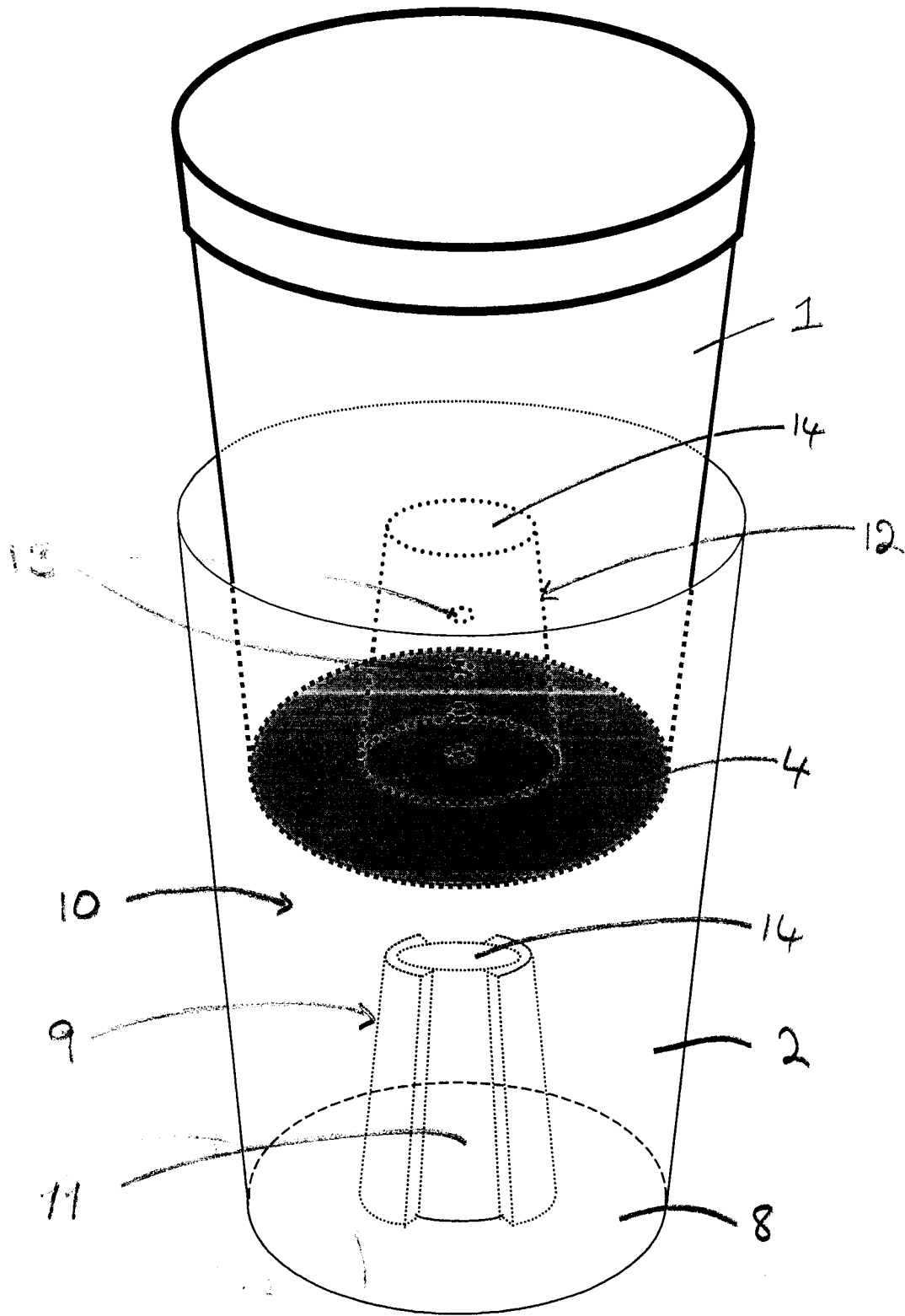

Fig 4.

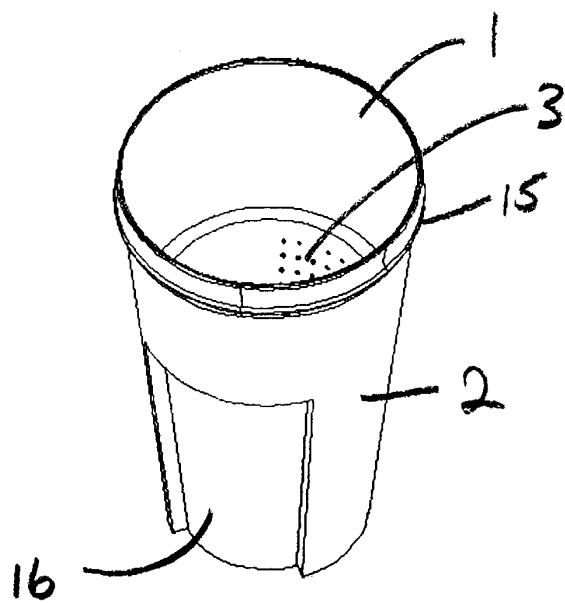

Fig 5

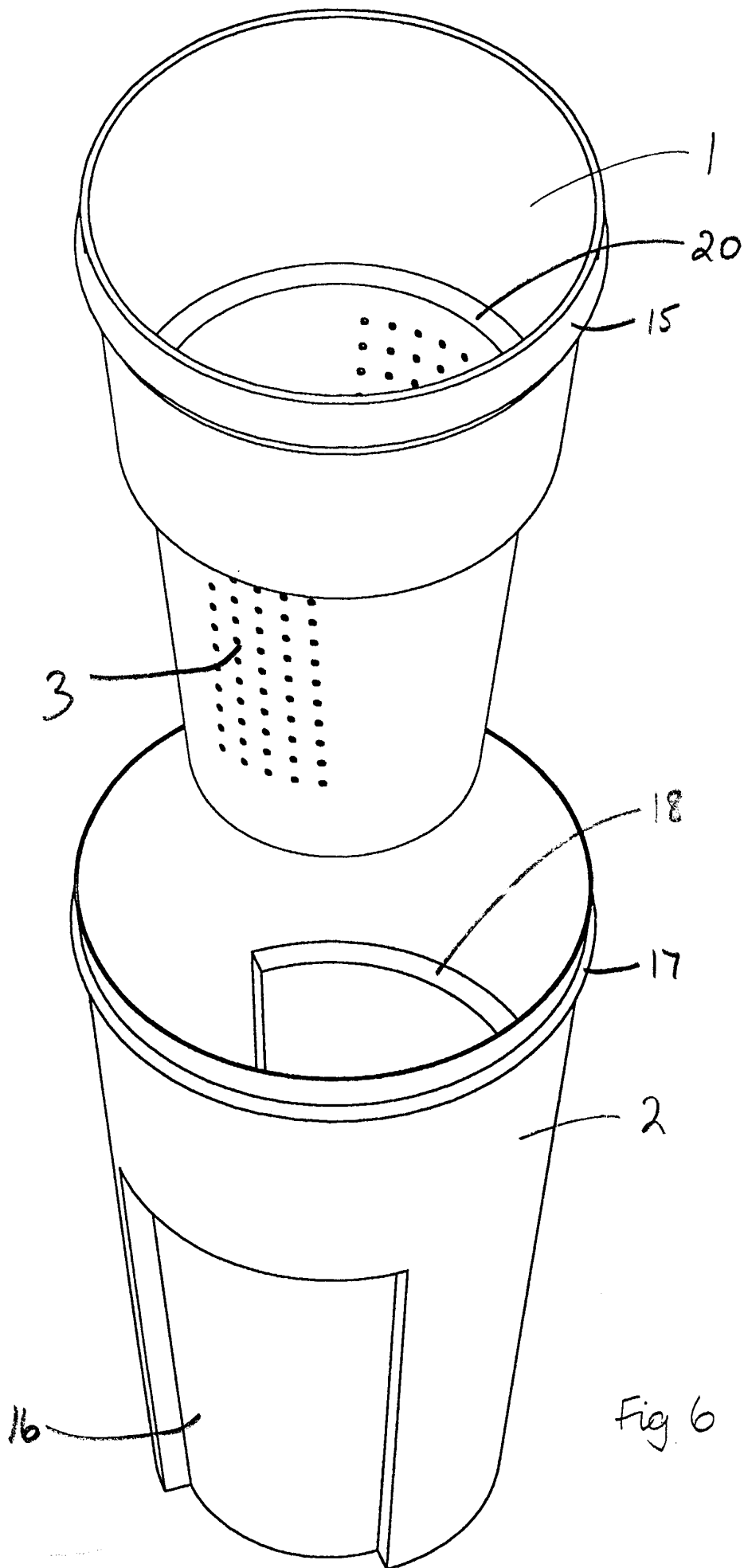

Fig 6

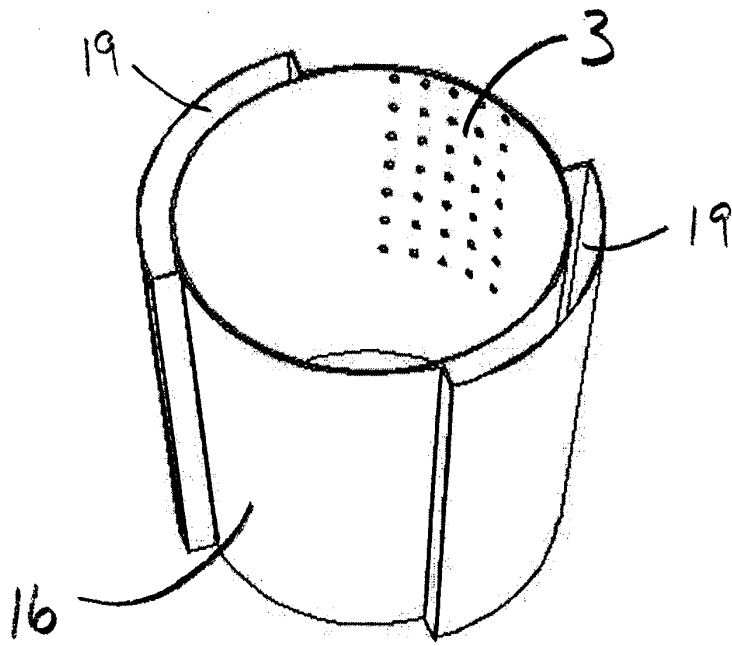

Fig. 7.