

(19)



(11)

EP 3 375 953 B1

(12)

EUROPEAN PATENT SPECIFICATION

(45) Date of publication and mention of the grant of the patent:
23.10.2019 Bulletin 2019/43

(51) Int Cl.:
E04G 1/14 (2006.01) *E04G 5/00 (2006.01)*
E04G 5/04 (2006.01) *E04G 5/06 (2006.01)*
E04G 5/16 (2006.01) *E04G 7/30 (2006.01)*
E04G 7/34 (2006.01) *E04G 7/32 (2006.01)*
E04G 1/15 (2006.01) *E04G 1/34 (2006.01)*

(21) Application number: **18162036.0**

(22) Date of filing: **15.03.2018**

(54) SWING GIRDER AND SCAFFOLD SYSTEM WITH SUCH SWING GIRDER AND A METHOD OF ERECTING THE SCAFFOLD SYSTEM

SCHWENKBARER TRÄGER UND GERÜSTSYSTEM MIT EINEM SOLCHEN SCHWENKBAREN TRÄGER UND VERFAHREN ZUM ERRICHTEN EINES SOLCHEN GERÜSTSYSTEMS

POUTRE PIVOTANTE ET SYSTÈME D'ÉCHAFAUDAGE AVEC UNE TELLE POUTRE PIVOTANTE ET PROCÉDÉ DE MONTAGE DU SYSTÈME D'ÉCHAFAUDAGE

(84) Designated Contracting States:
AL AT BE BG CH CY CZ DE DK EE ES FI FR GB GR HR HU IE IS IT LI LT LU LV MC MK MT NL NO PL PT RO RS SE SI SK SM TR

(30) Priority: **15.03.2017 NL 2018515**

(43) Date of publication of application:
19.09.2018 Bulletin 2018/38

(73) Proprietor: **Scafom Holding B.V.**
6021 PZ Budel (NL)

(72) Inventor: **Brinkmann, Franciscus Jozef Leonardus Hubertus**
6021 PZ Budel (NL)

(74) Representative: **V.O.**
P.O. Box 87930
Carnegieplein 5
2508 DH Den Haag (NL)

(56) References cited:
WO-A1-2013/066859 CA-A1- 2 740 549
KR-A- 20100 037 242 US-A1- 2005 217 936

EP 3 375 953 B1

Note: Within nine months of the publication of the mention of the grant of the European patent in the European Patent Bulletin, any person may give notice to the European Patent Office of opposition to that patent, in accordance with the Implementing Regulations. Notice of opposition shall not be deemed to have been filed until the opposition fee has been paid. (Art. 99(1) European Patent Convention).

DescriptionFIELD

[0001] The invention relates to a swing girder according to claim 1, a scaffold system according to claim 9 with such a swing girder and a method of erecting a scaffold system according to claim 14. The invention according to claim 1 relates to a swing girder that is suitable for application in a scaffold system where the scaffolds are provided at regular distances with ring-shaped rosettes having coupling recesses. Such a scaffold system is marketed by Scafom-rux under the brand name Ringscaff.

BACKGROUND

[0002] The Ringscaff system of Scafom-rux is described extensively in "The Ringscaff erection manual complete" of May 2011, downloadable via this link: <http://www.scafom-rux.com/uploads/documents/Handlei-dingen/2011-05-01-The-Ringscaff-erection-manual-complete.pdf>, which, inter alia on p. 73, accurately describes the configuration of the rosettes with coupling recesses, which rosettes are connected with the standards at regular distances. Further, on p. 74, the body, implemented as a casting, of a fixed ledger-wedge coupling is described, and described on p. 77 is the design of the wedge which is movably connected with the body of the ledger-wedge coupling. Page 72 shows a plan view and a side view of a node point where five horizontal ledgers are attached with a ledger-wedge coupling to the annular rosette of a standard.

[0003] CA 02740549 shows in Figure 3 a horizontal girder of the fixed type of which a lower girder coupling is not a wedge coupling but a coupling with a downwardly extending pin which can be inserted into an opening of a rosette of a standard.

[0004] WO 2013/066859 A1 shows in Figure 3 a horizontal swing girder. The known swing girder has the features described in the pre-characterizing portion of claim 1. In the known swing girder, the two fixed rosette couplings are implemented as conventional ledger-wedge couplings of which the body implemented as a casting is fixedly connected, by welding, with the respective first ends of the top tube and the bottom tube of the swing girder. The swing connector assembly of the known swing girder is implemented as two conventional ledger-wedge couplings of which the body implemented as a casting is pivotably connected via a bracket with the respective second ends of the top tube and the bottom tube of the swing girder.

[0005] A swing girder is intended to enable erection of cantilever platforms or of suspended platforms, allowing the platform to be created from an already erected scaffold, for example, for forming a working platform under a bridge or roof construction.

SUMMARY

[0006] A disadvantage of the known swing girder is that it is cumbersome to mount, so that mounting is time consuming and also brings safety risks. When the known swing girder is to be attached to a standard, two scaffolders should work together. This is because the swing girder has to be held by a first scaffolder while by a second scaffolder the lower pivotable ledger-wedge coupling is slid onto a rosette and the wedge is placed through a coupling recess in the rosette. These operations have to be done about 0.5 meters below the level of the floor which the scaffolder is on, so that, actually lying on the scaffold floor, he has to position the pivotable ledger-wedge coupling concerned and then place the wedge and strike it. Next, the second scaffolder can also position the upper pivotable ledger-wedge coupling by tilting the swing girder and by pivoting the upper pivotable ledger-wedge coupling relative to the associated rosette into the correct position so that the wedge can be placed through a coupling recess. After this, with the aid of a hammer, both wedges can be struck to fixedly connect the pivotable ledger-wedge couplings with the standard concerned.

[0007] The invention contemplates a swing girder that can be connected with a standard more easily, more particularly, if so desired, can be connected with a standard by just one scaffolder.

[0008] To this end, the invention provides a swing girder according to claim 1. More particularly, the invention provides a swing girder for use in a scaffold system of the ring scaffold type including standards having, arranged at regular distances, ring-shaped rosettes with coupling recesses. The swing girder according to the invention comprises:

- an upper chord or top-girder of which a top-girder axis extends in a swing girder plane in a swing girder main direction;
- a lower chord or bottom-girder of which a bottom-girder axis L2 extends parallel to the swing girder main direction in the swing girder plane;
- a number of connecting tubes which interconnect the top-girder and the bottom-girder with each other;
- two fixed rosette couplings, which are fixedly connected respectively with a first end of the top-girder and a first end of the bottom-girder;
- a swing connector assembly which comprises two pivotable rosette couplings which are connected respectively with a second end of the top-girder and a second end of the bottom-girder in a manner pivotable around a pivoting axis S.

[0009] The swing girder is characterized, according to the invention, in that a lower of the two pivotable rosette couplings is a pivotable girder-support coupling which includes a support plate extending perpendicular to the swing girder plane and the pivoting axis, which is con-

nected with the second end of the bottom-girder in a manner pivotable around the pivoting axis, wherein the pivotable girder-support coupling includes at least one positioning pin connected with the support plate, which is at a side of the support plate facing away from the top-girder.

[0010] Assembling a swing girder according to the invention may, if so desired, be carried out by a single scaffolder. The scaffolder places the at least one positioning pin of the pivotable girder-support coupling in a coupling opening of a rosette of a standard, with the support plate resting on the rosette, so that a large part of the weight of the swing girder at that moment is taken up by the respective rosette. The scaffolder can carry out this operation while standing. In any case, the scaffolder does not need to reach about 0.5 meters below the scaffold floor to perform the operation there and so does not need to lie down as described above in the discussion of the disadvantages of the known swing girder. Assembling the swing girder according to the invention is therefore more favorable from an ergonomic viewpoint. Moreover, assembly of the swing girder according to the invention can be carried out much faster because fewer operations are required. Moreover, as the scaffolder does not need to lie down or get down on his knees to carry out operations about 0.5 meters below the scaffold floor, he himself can continue to support the swing girder, so that a second scaffolder need not necessarily be present during placement of the swing girder according to the invention. After positioning of the girder-support coupling on a lower-situated rosette, the scaffolder proceeds to tilt the swing girder into a position in which the swing girder plane extends substantially vertically. The higher-situated rosette can then be simply coupled with the upper of the two pivotable rosette couplings.

[0011] The swing connector assembly further comprises a connecting rod which connects the two pivotable rosette couplings with each other, so that the two pivotable rosette couplings always have the same pivoted position around the pivoting axis relative to the swing girder plane. This in contrast to the swing girder known from WO 2013/066859 A1 where pivotable rosette couplings are connected with the top-girder and bottom-girder pivotably independently of each other. The effect achieved by the connecting rod is that the pivoted position of the two pivotable rosette couplings is always the same relative to the swing girder plane. This, in turn, simplifies coupling of the upper pivotable rosette coupling with a rosette because the upper coupling automatically has the right pivoted position after placement of the at least one positioning pin of the lower pivotable rosette coupling in a coupling recess of the associated rosette. Moreover, the connecting rod effects a better distribution of the forces on the two pivotable rosette couplings and the rosettes coupled thereto during mounting and swinging of the swing girder. This is of importance because during mounting and swinging of the swing girder, the interplay of forces on the rosette couplings and the rosettes con-

nected therewith is different than in the eventually mounted condition of the swing girder. The effect achieved by the connecting rod is that the forces on the two pivotable rosette couplings and the two rosettes connected therewith are approximately equally distributed.

[0012] The invention also provides a scaffold system according to claim 9. Such a scaffold system comprises:

- standards which are provided at regular distances with ring-shaped rosettes which are each provided with coupling recesses;
- ledgers which are provided at the ends with ledger-wedge couplings, each ledger-wedge coupling comprising a body provided with a receiving gap in which a ring-shaped rosette is receivable and each ledger-wedge coupling including a wedge which is movably connected with the body of the ledger coupling and which can be inserted through a coupling recess in the ring-shaped rosette and be struck for fixation and for forming a force-transmitting connection between the ledger and the standard; and
- swing girders according to the invention, with the distance between the top-girder and the bottom-girder of the swing girder substantially corresponding to the distance between two neighboring rosettes on the standards.

[0013] Such a scaffold system provides the possibility of erecting a cantilever platform with the aid of swing girders in a simple manner. The platform may then be realized by a single scaffolder. This in contrast to prior art scaffold systems with swing girders.

[0014] Finally, the invention provides a method of erecting a suspended platform according to claim 14. More particularly, the method according to the invention comprises:

- providing a scaffold system according to the combination of claims 12 and 13;
- stably setting up the pair of first standards utilizing either the suspension means thereof or the base jacks thereof and interconnecting the first standards of the pair with at least one ledger;
- connecting the swing connector assembly of the first swing girder with a first of the pair of first standards;
- attaching a hanging standard provided with suspension means to the fixed girder-support coupling and the fixed girder-wedge coupling of the first swing girder;
- connecting the swing connector assembly of the second swing girder with a second of the pair of first standards;
- attaching a hanging standard provided with suspension means to the fixed girder-support coupling and the fixed girder-wedge coupling of the second swing girder;
- swinging out the first swing girder and the second swing girder, and placing the diagonal brace for fix-

ation of the first swing girder in a position in which the main direction of the top-girder of the first swing girder extends perpendicular to the at least one ledger which connects the two standards of the pair of first standards with each other;

- placing the floor parts on the two swing girders;
- connecting the end girder with the rosettes of the two hanging standards; and
- attaching the suspension means of the two hanging standards to an overhead construction such as a bridge, roof or beam.

[0015] Such a method of erecting a platform that is at least in part suspended from an overhead construction, such as a bridge, a roof or a beam, can be carried out particularly fast and, if desired, even by a single scaffold-er. This is the consequence of the particular configuration of the swing girders according to the invention which are used in carrying out the method according to the invention.

[0016] Further embodiments of the invention are described in the subclaims and will be further clarified hereinafter on the basis of an example, with reference to the drawing.

BRIEF DESCRIPTION OF THE DRAWINGS

[0017]

Fig. 1 shows a perspective view of an example of a swing girder;

Fig. 2 shows a side view of the example of a swing girder represented in Figure 1, which is mounted between two standards;

Fig. 3 shows the swing connector assembly of the swing girder shown in Figure 1, in more detail in perspective;

Fig. 4 shows an example of an end girder;

Fig. 5 shows detail V of Figure 4;

Fig. 6 shows the first mounting operation of coupling the swing connector assembly of a swing girder with a standard;

Fig. 7 shows a conventional scaffold with a swing girder attached to the left-hand standard of the scaffold, the upper girder-wedge coupling fixed with a wedge;

Fig. 8 shows that a hanging standard has been mounted at the other end of the swing girder and thereupon safety ledgers have been mounted to the hanging standard;

Fig. 9 shows that a second swing girder has been attached to the right-hand standard of the conventional ring scaffold and that a diagonal brace has been arranged between a rosette of the first hanging standard and a rosette of the right-hand standard of the conventional ring scaffold;

Fig. 10 shows that the floor parts have been placed on the swing girders;

Fig. 11 shows that the end girder has been mounted as well as two safety ledgers which bound a remote end of the suspended platform; and

Fig. 12 shows a detail of an upper part of the suspension means and the associated fastening means for attachment to an overhead construction, in particular an I-beam.

DETAILED DESCRIPTION

[0018] The invention provides a swing girder 10 for use in a scaffold system of the ring scaffold type including standards 12, 112 having, arranged at regular distances, ring-shaped rosettes 14 (see Figure 2 and Figures 7-11) with coupling recesses 18 (see, for example, Figure 12). In most general terms, the swing girder 10, of which an example is shown in Figures 1 and 2, comprises an upper chord or top-girder 20 of which a top-girder axis L1 extends in a swing girder main direction, as well as a lower chord or bottom-girder 22 of which a bottom-girder axis L2 extends parallel to the swing girder main direction in the swing girder plane. The top-girder 20 and the bottom-girder 22 are mutually interconnected by a number of connecting tubes 24. The swing girder 10 has two fixed rosette couplings 26, 34 which are fixedly connected respectively with a first end of the top-girder 20 and a first end of the bottom-girder 22. Further, the swing girder 10 has a swing connector assembly 38 which comprises two pivotable rosette couplings 40, 48 which are connected respectively with a second end of the top-girder 20 and a second end of the bottom-girder 22 in a manner pivotable around a pivoting axis S. According to the invention, a lower of the two pivotable rosette couplings 40, 48 is a pivotable girder-support coupling 48 which includes a support plate 50, extending perpendicular to the swing girder plane and the pivoting axis, which is connected with the second end of the bottom-girder 22 in a manner pivotable around the pivoting axis (see Figure 3). The pivotable girder-support coupling 48 includes at least one positioning pin 52, connected with the support plate 50, which is on a side of the support plate 50 facing away from the top-girder 20.

[0019] The advantages of a thus-implemented swing girder have already been described hereinabove in the section of the description headed "Summary" and which is referred to here.

[0020] In an embodiment, of which an example is shown in the figures (see in particular Figure 3), the swing connector assembly 38 may further comprise a connecting rod 54 which connects the two pivotable rosette couplings 40, 48 with each other, so that the two pivotable rosette couplings 40, 48 always have the same pivoted position around the pivoting axis S relative to the swing girder plane. As already indicated above under the heading "Summary", such a connecting rod provides the advantage that the forces exerted on the pivotable rosette couplings and the associated rosettes during mounting and pivoting of the swing girder 10 are distributed better

over the two pivotable rosette couplings 40, 48 and the associated rosettes 14.

[0021] In an embodiment, of which an example is shown in the figures (see Figure 3), an upper of the two second rosette couplings 40, 48 can be a pivotable girder-wedge coupling 40 comprising a body 42 which is connected with a second end of the top-girder 20 in a manner pivotable around a pivoting axis, wherein the pivoting axis S extends in the swing girder plane and extends perpendicular to the top-girder axis L1, wherein the body 42 of the pivotable girder-wedge coupling 40 includes a receiving gap 44 which extends perpendicular to the swing girder plane and the pivoting axis S, and wherein the pivotable girder-wedge coupling 40 includes a wedge 46 which is movably connected with the body 42 of the pivotable girder-wedge coupling 40, wherein the pivotable girder-wedge coupling 40 provides a force-transmitting connection with a standard 12 when the wedge 46 is in a fixation condition.

[0022] A thus-implemented upper pivotable rosette coupling 40 provides for simple assembly. After the pivotable girder-support coupling 48 has been placed by way of the positioning pin 52 on a rosette 14 and rests thereon, the scaffolder can tilt the swing girder 10 into a vertical position (see Figure 6) so that the rosette 14 with which the pivotable girder-wedge coupling 40 is to be connected, is received in the receiving gap 44. The scaffolder then only needs to place the wedge 46 in the body 42, so that it extends through a coupling recess 18 of the respective rosette 14. After this operation, the swing girder 10 cannot fall down anymore and the wedge 46 then only needs to be struck with a hammer to establish a force-transmitting connection between the girder-wedge coupling 40 and the rosette 14 and fix these relative to each other. The condition then realized is shown in Figure 7.

[0023] After the attachment of the swing connector assembly 38 of the swing girder 10 to a standard 12, the scaffolder can attach, at the end with the two fixed rosette couplings 26, 34, a hanging standard 112 having therein premounted suspension means 120-126 (see Figures 8 and 12). To enable a simple attachment of the hanging standard 112, whereby the scaffolder does not need to stoop or go down on his knees to perform operations about 0.5 meters below the scaffold floor that he is on, according to an embodiment, of which an example is shown in the figures, a lower of the two fixed rosette couplings 26, 34 can be a fixed girder-support coupling 34. To that effect, see for example Figure 1, but Figure 5, while showing the fixed rosette couplings of an end girder 72, is also illustrative of this. Also this fixed girder-support coupling 34 then includes a support plate 36 extending perpendicular to the swing girder plane, which is fixedly connected with a first end of the bottom-girder 22. The girder-support coupling 34 then includes at least one positioning pin 38 connected with the support plate, which pin is on the side of the support plate 36 facing away from a top-girder 20. In this embodiment, an upper of the two

fixed rosette couplings 26, 34 is preferably implemented as a fixed girder-wedge coupling 26 which includes a body 28 which is fixedly connected with a first end of the top-girder 20. The body 28 has a receiving gap 30 which extends perpendicular to the swing girder plane. Further, the fixed girder-wedge coupling 26 includes a wedge 32 which is movably connected with the body 28 of the fixed girder-wedge coupling 26. The fixed girder-wedge coupling 26 provides a force-transmitting connection with a standard 12 when the wedge 32 is in a fixation condition.

[0024] When connecting a hanging standard 112 with the thus-implemented fixed rosette couplings 26, 34, a lower rosette 114 is first brought under the support plate 36 and moved up, so that the positioning pin 38 is received in the coupling recess of the lower rosette 114. Then, the scaffolder tilts the hanging standard 112 into a vertical position so that the higher-situated rosette 114 is received in the receiving gap 30 of the fixed girder-wedge coupling 26. Next, the scaffolder only needs to place the wedge 32 in the body 28 so that it extends through the coupling recess of the respective rosette 114. The hanging standard 112 now cannot fall anymore. To realize a fixed, force-transmitting connection, the scaffolder only needs to strike the wedge 32 in place with the aid of a hammer and the hanging standard 112 is fixedly connected with the swing girder 10. After these operations, the situation in Figure 8 has been reached.

[0025] In an embodiment, of which an example is shown in the figures, the pivotable girder-wedge coupling 40 may, as is clearly visible in Figures 1-3, comprise a U-shaped bracket 56 which includes two bracket legs 56a and a bracket body 56b. The bracket body 56b is fixedly connected with the body 42 of the pivotable girder-wedge coupling 40. In this embodiment, also the pivotable girder-support coupling 48 comprises a U-shaped bracket 58 which includes two bracket legs 58a and a bracket body 58b. The bracket body 58b is fixedly connected with the support plate 50 of the pivotable girder-support coupling 48. The earlier-mentioned connecting rod 54 interconnects the two U-shaped brackets 56, 58.

[0026] In a further elaboration of this embodiment, of which an example is shown in the figures, the top-girder 20 and the bottom-girder 22 may each be tubular. The second end of the top-girder 20 may then be received between the legs 56a of the U-shaped bracket 56 of the pivotable girder-wedge coupling 40. The second end of the bottom-girder 22 may then be received between the legs 58a of the U-shaped bracket 58 of the pivotable girder-support coupling 48. The two second ends of the top-girder 20 and the bottom-girder 22 may then be each provided with a hole which forms a passage. The swing connector assembly 38 can comprise a hinge pin 60 (see Figure 2) which extends along the pivoting axis S through the bracket legs 56a, 58a and the passages of the two second ends to form the pivotable connections between the body 42 of the pivotable girder-wedge coupling 40 and the top-girder 20 and between the support plate 50 of the pivotable girder-support coupling 48 and the bot-

tom-girder 22. The hinge pin 60 then forms the pivot of the swing connector assembly 38.

[0027] In an embodiment, of which an example is shown in the figures, the hinge pin 60 can extend through the connecting rod 54 which connects the pivotable girder-wedge coupling 40 with the pivotable girder-support coupling 48. The connecting rod 54 protects the hinge pin 60 from damage, for example when the swing girders 10 are stacked onto each other for storage.

[0028] In an embodiment, of which an example is shown in the figures, the at least one positioning pin 38, connected with the support plate 36 of the fixed girder-support coupling 34, and being on the side of the support plate 36 facing away from the top-girder 20, can comprise three positioning pins 38 (see Figure 1, in which one of the three positioning pins is visible).

[0029] Three positioning pins 38 provide for a stable positioning of the support plate 36 of the fixed girder-support coupling 34 relative to the rosette 14 on which the support plate 36 rests, in that each positioning pin 38 can be received in an associated coupling recesses 18 or in that, for example, outer positioning pins 38 abut against the circumferential edge of a coupling opening.

[0030] In an embodiment, of which an example is shown in the figures, the at least one positioning pin 52 connected with the support plate 50 of the pivotable girder-support coupling 48, and being on the side of the support plate 50 facing away from the top-girder 20, can comprise three positioning pins 52 (see also Figure 1, in which these three positioning pins 52 are visible).

[0031] Three positioning pins 52 can effect a more defined positioning of the support plate 50 relative to a rosette 14, for instance because each positioning pin 52 extends through a coupling opening 18 of the respective rosette 14. This minimizes the chance of the support plate 50 shifting relative to the rosette 14 during swinging of the swing girder 10, and forces that the support plate 50 exerts on the rosette 14 can be properly transmitted.

[0032] The invention also provides a scaffold system which comprises standards 12, 112 which are provided at regular distances with ring-shaped rosettes 14 which are each provided with coupling recesses 18. The scaffold system also comprises ledgers 62 which are provided at the ends with ledger-wedge couplings 64. As is known per se from, for example, the above-mentioned "Ringscaff erection manual complete", each ledger-wedge coupling comprises a body which is provided with a receiving gap in which a ring-shaped rosette 14 is receivable, and each ledger-wedge coupling 64 includes a wedge which is movably connected with the body of the ledger coupling 64 and which can be inserted through a coupling recess 18 in the ring-shaped rosette 14 and be struck for fixation and for forming a force-transmitting connection between the ledger 62 and the standard 12. The scaffold system is characterized according to the invention by swing girders 10 according to the invention, various embodiments of which have been described hereinabove. The distance between the top-girder 20 and

the bottom-girder 22 of the swing girder 10 substantially corresponds to the distance between two neighboring rosettes 14 or 14' on the standards 12 or 112. With the aid of such a scaffold system, a suspended platform can be built in a rapid and user-friendly manner. If desired, such a suspended platform can even be realized by a single scaffolder.

[0033] In an embodiment, of which an example is shown in the figures, the scaffold system may further include at least one end girder 72. An example of the end girder 72 is shown in detail in Figures 4 and 5. Such an end girder 72 comprises a upper chord or top-girder 74 of which a top-girder axis L3 extends in an end girder plane in an end girder main direction. Further, the end girder 72 comprises a lower chord or bottom-girder 76 of which a bottom-girder axis L4 extends parallel to the end girder main direction in the end girder plane. The top-girder 74 and the bottom-girder 76 are mutually interconnected by a number of connecting tubes 78. Further, the end girder 72 is provided with two end girder wedge couplings 80 which each include a body 82 which is fixedly connected with a first and a second end of the top-girder 74, respectively. Just as with a ledger-wedge coupling known per se, each body 82 is provided with a receiving gap 84. This receiving gap 84 extends perpendicular to the end girder plane. Each end girder wedge coupling 80 furthermore includes a wedge 86 which is movably connected with the body 82 of the end girder wedge coupling 80. Each end girder wedge coupling 80 provides a force-transmitting connection with a standard 112 connected therewith when the wedge 86 is in a fixation condition. Finally, the end girder 72 is provided with two end girder support couplings 88 each including a support plate 90 which extends perpendicular to the end girder plane and is fixedly connected with a first and a second end of the bottom-girder 76, respectively. Each end girder support coupling 88 includes at least one positioning pin 92 connected with the support plate 90 and which is on a side of the support plate 90 facing away from the top-girder 74.

[0034] In an embodiment, of which an example is shown in the figures, the scaffold system (see Figure 11) comprises, for forming a suspended platform, at least two swing girders 10, 10' according to any one of claims 3-8. That is, swing girders 10, 10' provided at a first end with a fixed girder-support coupling 34 and a fixed girder-wedge coupling 26 and provided at the second end with a pivotable girder-support coupling 48 and a pivotable girder-wedge coupling 40. Further, the scaffold system may include at least one end girder 72 as described above and a pair of first standards 12, 12' which are each provided with either suspension means or a base jack 70 for supporting the respective standard 12, 12'. Base jacks 70 are known per se from the "Ringscaff erection manual complete" already mentioned above. With each standard 12, 12' of the pair of first standards, a swing connector assembly 38, 38' of an associated swing girder 10, 10' of the two swing girders may be connected. The scaffold system according to this embodiment may fur-

ther comprise two hanging standards 112, 112' which are provided with suspension means for attaching the two hanging standards 112, 112' to an overhead construction, such as a bridge, a roof or a beam. Each of the two hanging standards 112, 112' is then connected with the fixed girder-support coupling 34, 34' and the fixed girder-wedge coupling 26, 26' of an associated swing girder 10, 10' of the two swing girders 10, 10'. Furthermore, each end of the end girder 72 is connected with one of the hanging standards 112, 112'. Finally, this embodiment of the scaffold system comprises floor parts 94 which rest on and extend transversely to the two swing girders 10, 10'.

[0035] In an embodiment, of which an example is shown in the figures, this embodiment of the scaffold system may include a diagonal brace 96 (see Figure 9) which connects a rosette 114 of a hanging standard 112 as mentioned with a rosette 14' of standard 12' of the pair of first standards 12, 12' mentioned. The length of the diagonal brace 96 is such that in mounted condition of the diagonal brace 96, the main direction of the top-girder 20 of the swing girder 10 that is connected with the respective hanging standard 112 extends perpendicular to the ledger 62 which extends between the two standards 12, 12' of the pair of first standards 12, 12'.

[0036] In an embodiment, of which an example is shown in the figures (see in particular Figures 8 and 12), the suspension means of a hanging standard 112 can comprise a rod 120 which is provided with outer thread and which extends through the hanging standard 112. Further, the suspension means 120-134 in this embodiment comprise a supporting nut 122 which in mounted condition supports an underside of the hanging standard 112. A first lock nut 124 locks the position of the supporting nut 122 on the rod 120. The suspension means further comprise a rotatable turnbuckle 126 which is provided with inner thread by which it is connected with an upper end of the rod 120. With the aid of a second lock nut 128, the position of the rotatable turnbuckle 126 on the rod 120 is locked. Finally, the suspension means comprise fastening means 130, 132, 134 with which the rotatable turnbuckle 126 is rotatably connected and which are configured for attachment of the rotatable turnbuckle 126 to an overhead structure such as a bridge or roof or beam. The fastening means 130-134 can comprise, for example, a suspension eye 130 through which a suspension rod 132 has been passed. The suspension rod 132 can be connected using clamps 134 with, for example, an I-beam, as shown in Figure 12. It will be clear that other types of fastening means for connecting the turnbuckle 126 with an overhead construction are also possible. The suspension eye 130, the suspension rod 132 and the clamps 134 as shown merely serve as examples. With the aid of the turnbuckle 126 which is rotatably connected with the fastening means, in the example shown being rotatably connected with the suspension eye 130, the height of the suspended scaffold platform to be created can be set, so that the platform can be properly horizon-

tally aligned.

[0037] The invention also provides a method of erecting a suspended platform. The various steps of the method are shown in the exemplary Figures 6-12. The method comprises:

- providing a scaffold system according to the combination of claims 12 and 13, that is, a scaffold system of which various embodiments have been described hereinabove and which in any case comprises: two of the described swing girders 10, 10', a pair of first standards 12, 12', two hanging standards 112, 112', suspension means 120-134, a diagonal brace 96, and a horizontal ledger 62.

The method further comprises:

- stably setting up the pair of first standards 12, 12' utilizing either the suspension means thereof or the base jacks 70 thereof and mutually connecting the first standards 12, 12' of the pair with at least one ledger 62;
- connecting the swing connector assembly 38 of the first swing girder 10 with a first 12 of the pair of first standards 12, 12' (see Figures 6 and 7);
- attaching a hanging standard 112 provided with suspension means to the fixed girder-support coupling 34 and the fixed girder-wedge coupling 26 of the first swing girder 10 (see Figure 8);
- connecting the swing connector assembly 38' of the second swing girder 10' with a second 12' of the pair of first standards 12, 12' (see Figure 9);
- attaching a hanging standard 112' provided with suspension means to the fixed girder-support coupling 34' and the fixed girder-wedge coupling 26' of the second swing girder 10' (see Figure 9);
- swinging out the first swing girder 10 and the second swing girder 10', and placing the diagonal brace 96 for fixation of the first swing girder 10 in a position in which the main direction of the top-girder 20 of the first swing girder 10 extends perpendicular to the at least one ledger 62 which connects the two standards 12, 12' of the pair of first standards with each other (see Figure 9);
- placing the floor parts 94 on the two swing girders 10, 10' (see Figure 10);
- connecting the end girder 72 with the rosettes 114, 114' of the two hanging standards 112, 112' (see Figure 11); and
- attaching the suspension means 120-134 of the two hanging standards 112, 112' to an overhead construction such as a bridge, roof or beam (see Figure 12).

[0038] All these operations can be carried out without the scaffolder needing to perform any operations for which he has to reach about 0.5 meters below the scaffold floor he is on. It is possible, if so desired, for all these

operations to be carried out by a single scaffolder. Moreover, the operations can be carried out relatively quickly because, compared with the known swing girder, there is only half the number of girder-wedge couplings to be positioned, wedges to be placed and struck with a hammer.

[0039] To enhance safety further, in an embodiment of the method, of which an example is shown in the figures, the method can further comprise:

- prior to the swinging out of a first and second swing girder 10, 10', connecting with the hanging standards 112, 112' at least one safety ledger 140, 140' to a rosette 114, 114' which is above the rosettes 114, 114' with which the respective swing girder 10, 10' is connected with the hanging standard 112, 112' (see Figure 8);
- after swinging out of the respective swing girder 10, 10', connecting the at least one safety ledger 140, 140' with a rosette 14, 14' of the standard 12, 12' of the pair of first standards 12, 12' with which the respective swing girder 10, 10' is connected.

[0040] This way, therefore, the safety ledgers 140, 140' can be arranged directly, even before swinging out the swing girder 10, 10', so that before the floor parts 94 are placed, the safety ledgers 140, 140', such as, for example, a safety ledger at knee height and a safety ledger 140 at hip height, are already present. The safety ledgers 140, 140' are then directly available for attaching thereto a life line which scaffolders are obliged to work with during erection of a scaffold.

[0041] In an embodiment of the method, of which an example is shown in the figures, the method can further comprise:

- directly before or directly after placing of the end girder 72, attaching at least one safety ledger 142 which extends between the two hanging standards 112, 112' and which is connected with the rosettes 114, 114' of the hanging standards 112, 112' that are above the rosettes 114, 114' of the hanging standards 112, 112' with which the end girder 72 is connected.

It will be clear that this step, too, contributes to a further enhancement of safety.

[0042] In an embodiment of the method, of which an example is shown in the figures, connecting the swing connector assembly 38 of the first swing girder 10 with a first 12 of the pair of standards 12, 12' and/or connecting the swing connector assembly 38' of the second swing girder 10' with a second 12' of the pair of standards 12, 12' can comprise:

- inserting the at least one positioning pin 52 of the pivotable girder-support coupling 48 into a first rosette 14, 14' of a respective standard 12, 12' (see

Figure 6);

- tilting the respective swing girder 10, 10' into a position in which the swing girder plane extends substantially vertically and an upper rosette 14, 14' is received in the receiving gap 44 of the pivotable girder-wedge coupling 40 (see Figure 6);
- inserting the wedge 46 of the pivotable girder-wedge coupling 40 through a coupling recess 18 of the upper rosette 14 and striking the wedge 46 with the aid of a hammer.

[0043] Thus connecting the swing connector assembly 38 of a swing girder 10 with a standard 12, 12' can, if desired, be carried out by a single scaffolder and provides a safe and quick way of attaching a swing girder 10, 10' to a standard 12, 12'. The activities can all be carried out by a scaffolder from a standing position, which is particularly favorable from an ergonomic viewpoint.

[0044] In an embodiment of the method, of which an example is shown in the figures, connecting the end girder 72 with the rosettes 114, 114' of the two hanging standards 112, 112' can comprise:

- inserting the positioning pins 92 of the two end girder support couplings 88 into two rosettes 114, 114' of the two hanging standards 112, 112' that are positioned at an equal level;
- tilting the end girder 72 into a position in which the end girder plane extends substantially vertically and the two upper rosettes 114, 114' of the respective hanging standards 112, 112' are received in the receiving gaps 84 of two associated end girder wedge couplings 80;
- inserting the wedge 86 of each end girder wedge coupling 80 through a coupling recess 18 of the associated upper rosette 114, 114' and striking the wedge 86 with the aid of a hammer.

[0045] This method of placing an end girder 72, too, is favorable from an ergonomic viewpoint and can be carried out by a single scaffolder.

[0046] The various embodiments described hereinabove can be used independently of each other and combined with each other in different ways, according to the claims. The reference numerals in the detailed description and the claims do not limit the description of the embodiments and the claims and are for clarification only.

Claims

1. A swing girder (10) for use in a scaffold system of the ring scaffold type including standards (12, 112) having, arranged at regular distances, ring-shaped rosettes (14) with coupling recesses (18), the swing girder (10) comprising:

- a top-girder (20) of which a top-girder axis (L1) extends in a swing girder plane in a swing girder main direction;
- a bottom-girder (22) of which a bottom-girder axis (L2) extends parallel to the swing girder main direction in the swing girder plane;
- a number of connecting tubes (24) which interconnect the top-girder (20) and the bottom-girder (22) with each other;
- two fixed rosette couplings (26, 34) which are fixedly connected respectively with a first end of the top-girder (20) and a first end of the bottom-girder (22);
- a swing connector assembly (38) which comprises two pivotable rosette couplings (40, 48) which are connected respectively with a second end of the top-girder (20) and a second end of the bottom-girder (22) in a manner pivotable around a pivoting axis (S);

characterized in that

- a lower of the two pivotable rosette couplings (40, 48) is a pivotable girder-support coupling (48) which includes a support plate (50) extending perpendicular to the swing girder plane and the pivoting axis (S) which is connected with the second end of the bottom-girder (22) in a manner pivotable around the pivoting axis (S), wherein the pivotable girder-support coupling (48) includes at least one positioning pin (52) connected with the support plate (50), which is at a side of the support plate (50) facing away from the top-girder (20);

wherein the swing connector assembly (38) further comprises:

- a connecting rod (54) which connects the two pivotable rosette couplings (40, 48) with each other, so that the two pivotable rosette couplings (40, 48) always have the same pivoted position around the pivoting axis (S) relative to the swing girder plane.

2. The swing girder (10) according to claim 1,

- wherein an upper of the two pivotable rosette couplings (40, 48) is a pivotable girder-wedge coupling (40) which includes a body (42) which is connected with a second end of the top-girder (20) in a manner pivotable around a pivoting axis, wherein the pivoting axis (S) extends in the swing girder plane and extends perpendicular to the top-girder axis (L1), wherein the body (42) of the pivotable girder-wedge coupling (40) is provided with a receiving gap (44) which extends perpendicular to the swing girder plane and the

pivoting axis (S), and wherein the pivotable girder-wedge coupling (40) includes a wedge (46) which is movably connected with the body (42) of the pivotable girder-wedge coupling (40), wherein the pivotable girder-wedge coupling (40) provides a force-transmitting connection with a standard (12) when the wedge (46) is in a fixation condition.

3. The swing girder according to claim 2, wherein a lower of the two fixed rosette couplings (26, 34) is a fixed girder-support coupling (34) which includes a support plate (36) extending perpendicular to the swing girder plane, which is fixedly connected with a first end of the bottom-girder (22), wherein the girder-support coupling (34) includes at least one positioning pin (38) connected with the support plate, which is at the side of the support plate (36) facing away from a top-girder (20); and wherein an upper of the two fixed rosette couplings (26, 34) is a fixed girder-wedge coupling (26) which includes a body (28) which is fixedly connected with a first end of the top-girder (20), wherein the body (28) is provided with a receiving gap (30) which extends perpendicular to the swing girder plane, wherein the fixed girder-wedge coupling (26) includes a wedge (32) which is movably connected with the body (28) of the fixed girder-wedge coupling (26), wherein the fixed girder-wedge coupling (26) provides a force-transmitting connection with a standard (12) when the wedge (32) is in a fixation condition.

4. The swing girder according to claim 2 or 3, wherein the pivotable girder-wedge coupling (40) comprises a U-shaped bracket (56) including two bracket legs (56a) and a bracket body (56b), wherein the bracket body (56b) is fixedly connected with the body (42) of the pivotable girder-wedge coupling (40), wherein the pivotable girder-support coupling (48) comprises a U-shaped bracket (58) including two bracket legs (58a) and a bracket body (58b), wherein the bracket body (58b) is fixedly connected with the support plate (50) of the pivotable girder-support coupling (48), wherein the connecting rod (54) interconnects the two U-shaped brackets (56, 58).

5. The swing girder according to claim 4, wherein the top-girder (20) and the bottom-girder (22) are each tubular, wherein the second end of the top-girder (20) is received between the legs (56a) of the U-shaped bracket (56) of the pivotable girder-wedge coupling (40), wherein the second end of the bottom-girder (22) is received between the legs (58a) of the U-shaped

- bracket (58) of the pivotable girder-support coupling (48),
 wherein the two second ends of the top-girder (20) and the bottom-girder (22) are each provided with a hole which forms a passage,
 wherein the swing connector assembly (38) comprises a hinge pin (60) which extends along the pivoting axis (S) through the bracket legs (56a, 58a) and the passages of the two second ends for forming the pivotable connections between the body (42) of the pivotable girder-wedge coupling (40) and the top-girder (20) and between the support plate (50) of the pivotable girder-support coupling (48) and the bottom-girder (22).
6. The swing girder according to claim 5, wherein the hinge pin (60) extends through the connecting rod (54) which connects the pivotable girder-wedge coupling (40) with the pivotable girder-support coupling (48).
7. The swing girder according to Claim 3 or claims 4-6 when dependent on claim 3, wherein the at least one positioning pin (38) connected with the support plate (36) of the fixed girder-support coupling (34), which is at the side of the support plate (36) facing away from the top-girder (20), comprises three positioning pins (38).
8. The swing girder according to any one of claims 2-7, wherein the at least one positioning pin (52) connected with the support plate (50) of the pivotable girder-support coupling (48), which is at the side of the support plate (50) facing away from the top-girder (20), comprises three positioning pins (52).
9. A scaffold system comprising:
- standards (12, 112) which are provided at regular distances with ring-shaped rosettes (14) which are each provided with coupling recesses (18);
 - ledgers (62) which are provided at the ends with ledger-wedge couplings (64), each ledger-wedge coupling comprising a body which is provided with a receiving gap in which a ring-shaped rosette (14) is receivable and each ledger-wedge coupling (64) including a wedge which is movably connected with the body of the ledger coupling (64) and which can be inserted through a coupling recess (18) in the ring-shaped rosette (14) and be struck for fixation and for forming a force-transmitting connection between the ledger (62) and the standard (12);
 - swing girders (10), according to any one of the preceding claims, wherein the distance between the top-girder (20) and the bottom-girder (22) of the swing girder (10) substantially corresponds to the distance between two neighboring rosettes (14 or 14') on the standards (12 or 112).
10. The scaffold system according to claim 9, further including at least one end girder (72) which comprises:
- a top-girder (74) of which a top-girder axis (L3) extends in an end girder plane in an end girder main direction;
 - a bottom-girder (76) of which a bottom-girder axis (L4) extends parallel to the end girder main direction in the end girder plane;
 - a number of connecting tubes (78) which interconnect the top-girder (74) and the bottom-girder (76) with each other;
 - two end girder wedge couplings (80) which each include a body (82) which is fixedly connected respectively with a first and a second end of the top-girder (74), wherein each body (82) is provided with a receiving gap (84) which extends perpendicular to the end girder plane, wherein each end girder wedge coupling (80) includes a wedge (86) which is movably connected with the body (82) of the end girder wedge coupling (80), wherein each end girder wedge coupling (80) provides a force-transmitting connection with an associated standard (112) when the wedge (86) is in a fixation condition;
 - two end girder support couplings (88) which each include a support plate (90) extending perpendicular to the end girder plane, which is fixedly connected respectively with a first and a second end of the bottom-girder (76), wherein each end girder support coupling (88) includes at least one positioning pin (92) connected with the support plate (90), which is at a side of the support plate (90) facing away from the top-girder (74).
11. The scaffold system according to claim 10, which for forming a suspended platform comprises at least:
- two of said swing girders (10, 10') according to any one of claims 4-8;
 - an end girder as mentioned (72);
 - a pair of first standards (12, 12') which are each provided with either suspension means or a base jack (70) to support the respective standard (12, 12'), wherein with each standard (12, 12') of the pair of first standards a swing connector assembly (38, 38') of an associated swing girder (10, 10') of the two swing girders is connected;
 - two hanging standards (112, 112') provided with suspension means for attaching the two hanging standards (112, 112') to an overhead construction, such as a bridge, a roof or a beam,

- wherein each of the two hanging standards (112, 112') is connected with the fixed girder-support coupling (48, 48') and the fixed girder-wedge coupling (40, 40') of an associated swing girder (10, 10') of said two swing girders, wherein each end of the end girder (72) is connected with one of said hanging standards (112, 112'); and
- floor parts (94) which rest on and extend transversely to the two swing girders (10, 10').
- 12.** The scaffold system according to claim 11, comprising:
- a diagonal brace (96) which connects a rosette (114) of a hanging standard (112) with a rosette (14') of standard (12') of said pair of first standards (12, 12'), and the length of which is such that in mounted condition of the diagonal brace (96) the main direction of the top-girder (20) of the swing girder (10) which is connected with the respective hanging standard (112) extends perpendicular to the ledger (62) which extends between the two standards (12, 12') of the pair of first standards (12, 12').
- 13.** The scaffold system according to claim 11 or 12, wherein the suspension means of a hanging standard (112) comprise:
- a rod (120) which is provided with outer thread and which extends through the hanging standard (112);
 - a support nut (122) which in mounted condition supports an underside of the hanging standard (112);
 - a first lock nut (124) which locks the position of the support nut (122) on the rod (120);
 - a rotatable turnbuckle (126) which is provided with inner thread and is therewith connected with an upper end of the rod (120);
 - a second lock nut (128) which locks the position of the rotatable turnbuckle (126) on the rod (120);
 - fastening means (130, 132, 134) with which the rotatable turnbuckle (126) is rotatably connected and which are configured for attachment of the rotatable turnbuckle (126) to an overhead construction such as a bridge or roof or beam.
- 14.** A method of erecting a suspended platform, comprising:
- providing a scaffold system according to the combination of claims 12 and 13;
 - stably setting up the pair of first standards (12, 12') utilizing either the suspension means thereof or the base jacks (70) thereof and interconnecting the first standards (12, 12') of the pair with at least one ledger (62);
 - connecting the swing connector assembly (38) of the first swing girder (10) with a first (12) of the pair of first standards (12, 12');
 - attaching a hanging standard (112) provided with suspension means to the fixed girder-support coupling (34) and the fixed girder-wedge coupling (26) of the first swing girder (10);
 - connecting the swing connector assembly (38') of the second swing girder (10') with a second (12') of the pair of first standards (12, 12');
 - attaching a hanging standard (112') provided with suspension means to the fixed girder-support coupling (34') and the fixed girder-wedge coupling (26') of the second swing girder (10');
 - swinging out the first swing girder (10) and the second swing girder (10'), and placing the diagonal brace (96) for fixation of the first swing girder (10) in a position in which the main direction of the top-girder (20) of the first swing girder (10) extends perpendicular to the at least one ledger (62) which connects the two standards (12, 12') of the pair of first standards with each other;
 - placing the floor parts (94) on the two swing girders (10, 10');
 - connecting the end girder (72) with the rosettes (114, 114') of the two hanging standards (112, 112'); and
 - attaching the suspension means of the two hanging standards (112, 112') to an overhead construction such as a bridge, roof or beam.
- 15.** The method according to claim 14, comprising:
- prior to swinging out a first and second swing girder (10, 10'), connecting with the hanging standards (112, 112') at least one safety ledger (140, 140') to a rosette (114, 114') which is above the rosettes (114, 114') with which the respective swing girder (10, 10') is connected with the hanging standard (112, 112');
 - after swinging out the respective swing girder (10, 10'), connecting the at least one safety ledger (140) with a rosette (14, 14') of the standard (12, 12') of the pair of first standards (12, 12') with which the respective swing girder (10, 10') is connected.
- 16.** The method according to claim 14 or 15, comprising:
- directly before or directly after placing the end girder (72), attaching at least one safety ledger (142) which extends between the two hanging standards (112, 112') and which is connected with the rosettes (114, 114') of the hanging

standards (112, 112') that are above the rosettes (114, 114') of the hanging standards (112, 112') with which the end girder (72) is connected.

17. The method according to any one of claims 14-16, wherein connecting the swing connector assembly (38) of the first swing girder (10) with a first (12) of the pair of standards (12, 12') and/or connecting the swing connector assembly (38') of the second swing girder (10') with a second (12') of the pair of standards (12, 12') comprises:

- inserting the at least one positioning pin (52) of the pivotable girder-support coupling (48) into a first rosette (14, 14') of a respective standard (12, 12');
- tilting the respective swing girder (10, 10') into a position in which the swing girder plane extends substantially vertically and an upper rosette (14, 14') is received in the receiving gap (44) of the pivotable girder-wedge coupling (40);
- inserting the wedge (46) of the pivotable girder-wedge coupling (40) through a coupling recess (18) of the upper rosette (14) and striking the wedge (46) with the aid of a hammer.

18. The method according to any one of claims 14-17, wherein connecting the end girder (72) with the rosettes (114, 114') of the two hanging standards (112, 112') comprises:

- inserting the positioning pins (92) of the two end girder support couplings (88) into two rosettes (114, 114') of the two hanging standards (112, 112') that are positioned at an equal level;
- tilting the end girder (72) into a position in which the end girder plane extends substantially vertically and the two upper rosettes (114, 114') of the respective hanging standards (112, 112') are received in the receiving gaps (84) of two associated end girder wedge couplings (80);
- inserting the wedge (86) of each end girder wedge coupling (80) through a coupling recess (18) of the associated upper rosette (114, 114') and striking the wedge (86) with the aid of a hammer.

Patentansprüche

1. Schwenkträger (10) zur Verwendung in einem Gerüstsystem vom Ringgerüsttyp, umfassend Ständer (12, 112) mit in regelmäßigen Abständen angeordneten ringförmigen Rosetten (14) mit Kupplungsaussparungen (18), wobei der Schwenkträger (10) Folgendes umfasst:

- einen Oberträger (20), von dem sich eine Ober-

trägerachse (L1) in einer Schwenkträgerebene in einer Schwenkträgerhaupttrichtung erstreckt;

- einen Unterträger (22), dessen Unterträgerachse (L2) sich parallel zur Schwenkträgerhaupttrichtung in der Schwenkträgerebene erstreckt;

- eine Anzahl von Verbindungsrohren (24), die den Oberträger (20) und den Unterträger (22) miteinander verbinden;

- zwei feste Rosettenkupplungen (26, 34), die jeweils mit einem ersten Ende des Oberträgers (20) und einem ersten Ende des Unterträgers (22) fest verbunden sind;

- eine Schwenkverbinderanordnung (38), die zwei schwenkbare Rosettenkupplungen (40, 48) umfasst, die jeweils mit einem zweiten Ende des Oberträgers (20) und einem zweiten Ende des Unterträgers (22) schwenkbar um eine Schwenkachse (S) verbunden sind;

dadurch gekennzeichnet, dass

- eine untere der beiden schwenkbaren Rosettenkupplungen (40, 48) eine schwenkbare Trägerstützkupplung (48) ist, die eine sich senkrecht zur Schwenkträgerebene und der Schwenkachse (S) erstreckende Stützplatte (50), die mit dem zweiten Ende des Unterträgers (22) auf um die Schwenkachse (S) schwenkbare Weise verbunden ist, wobei die schwenkbare Trägerstützkupplung (48) wenigstens einen mit der Stützplatte (50) verbundenen Positionierstift (52) aufweist, der sich auf einer dem Oberträger (20) abgewandten Seite der Stützplatte (50) befindet;

wobei die Schwenkverbinderanordnung (38) ferner Folgendes umfasst:

- eine Verbindungsstange (54), die die beiden schwenkbaren Rosettenkupplungen (40, 48) miteinander verbindet, so dass die beiden schwenkbaren Rosettenkupplungen (40, 48) immer die gleiche geschwenkte Position um die Schwenkachse (S) in Bezug auf Schwenkträgerebene haben.

2. Schwenkträger (10) nach Anspruch 1,

- wobei eine obere der beiden schwenkbaren Rosettenkupplungen (40, 48) eine schwenkbare Trägerkeilkupplung (40) ist, die einen Körper (42) aufweist, der mit einem zweiten Ende des Oberträgers (20) schwenkbar um eine Schwenkachse verbunden ist, wobei sich die Schwenkachse (S) in der Schwenkträgerebene erstreckt und sich senkrecht zur Oberträgerachse (L1) erstreckt, wobei der Körper (42) der

- schwenkbaren Trägerkeilkupplung (40) mit einem sich senkrecht zur Schwenkträgerebene und zur Schwenkachse (S) erstreckenden Aufnahmespalt (44) versehen ist, und wobei die schwenkbare Trägerkeilkupplung (40) einen mit dem Körper (42) beweglich verbundenen Keil (46) der schwenkbaren Trägerkeilkupplung (40) aufweist, wobei die schwenkbare Trägerkeilkupplung (40) eine kraftübertragende Verbindung mit einem Ständer (12) bereitstellt, wenn sich der Keil (46) in einem Befestigungszustand befindet.
3. Schwenkträger nach Anspruch 2, wobei eine untere der beiden festen Rosettenkupplungen (26, 34) eine feste Trägerstützkupplung (34) ist, die eine sich senkrecht zur Schwenkträgerebene erstreckende Stützplatte (36) aufweist, die mit einem ersten Ende des Unterträgers (22) fest verbunden ist, wobei die Trägerstützkupplung (34) wenigstens einen Positionierstift (38) aufweist, der mit der Stützplatte verbunden ist, die sich auf der Seite der Stützplatte (36) befindet, die von einem Oberträger (20) abgewandt ist; und wobei eine obere der beiden festen Rosettenkupplungen (26, 34) eine feste Trägerkeilkupplung (26) ist, die einen Körper (28) aufweist, der mit einem ersten Ende des Oberträgers (20) fest verbunden ist, wobei der Körper (28) mit einem Aufnahmespalt (30) versehen ist, der sich senkrecht zur Schwenkträgerebene erstreckt, wobei die feste Trägerkeilkupplung (26) einen Keil (32) aufweist, der beweglich mit dem Körper (28) der festen Trägerkeilkupplung (26) verbunden ist, wobei die feste Trägerkeilkupplung (26) eine kraftübertragende Verbindung mit einem Ständer (12) bereitstellt, wenn sich der Keil (32) in einem Befestigungszustand befindet.
4. Schwenkträger nach Anspruch 2 oder 3, wobei die schwenkbare Trägerkeilkupplung (40) eine U-förmige Halterung (56) mit zwei Halterungsschenkeln (56a) und einem Halterungskörper (56b) umfasst, wobei der Halterungskörper (56b) fest mit dem Körper (42) der schwenkbaren Trägerkeilkupplung (40) verbunden ist, wobei die schwenkbare Trägerstützkupplung (48) eine U-förmige Halterung (58) mit zwei Halterungsschenkeln (58a) und einem Halterungskörper (58b) umfasst, wobei der Halterungskörper (58b) fest mit der Stützplatte (50) der schwenkbaren Trägerstützkupplung (48) verbunden ist, wobei die Verbindungsstange (54) die beiden U-förmigen Halterungen (56, 58) miteinander verbindet.
5. Schwenkträger nach Anspruch 4, wobei der Oberträger (20) und der Unterträger (22) jeweils rohrförmig sind, wobei das zweite Ende des Oberträgers (20) zwischen den Schenkeln (56a) der U-förmigen Halterung (56) der schwenkbaren Trägerkeilkupplung (40) aufgenommen wird, wobei das zweite Ende des Unterträgers (22) zwischen den Schenkeln (58a) der U-förmigen Halterung (58) der schwenkbaren Trägerstützkupplung (48) aufgenommen wird, wobei die beiden zweiten Enden des Oberträgers (20) und des Unterträgers (22) jeweils mit einem Loch versehen sind, das einen Durchgang bildet, wobei die Schwenkverbinderanordnung (38) einen Gelenkstift (60) umfasst, der sich entlang der Schwenkachse (S) durch die Halterungsschenkel (56a, 58a) und die Durchgänge der beiden zweiten Enden erstreckt, um die schwenkbaren Verbindungen zwischen dem Körper (42) der schwenkbaren Trägerkeilkupplung (40) und des Oberträgers (20) sowie zwischen der Stützplatte (50) der schwenkbaren Trägerstützkupplung (48) und dem Unterträger (22) zu bilden.
6. Schwenkträger nach Anspruch 5, wobei sich der Gelenkstift (60) durch die Verbindungsstange (54) erstreckt, die die schwenkbare Trägerkeilkupplung (40) mit der schwenkbaren Trägerstützkupplung (48) verbindet.
7. Schwenkträger nach Anspruch 3 oder den Ansprüchen 4 bis 6, wenn abhängig von Anspruch 3, wobei der wenigstens eine Positionierstift (38) mit der Stützplatte (36) der festen Trägerstützkupplung (34) verbunden ist, die sich an der dem Oberträger (20) abgewandten Seite der Stützplatte (36) befindet, drei Positionierstifte (38) umfasst.
8. Schwenkträger nach einem der Ansprüche 2 bis 7, wobei der wenigstens eine Positionierstift (52) mit der Stützplatte (50) der schwenkbaren Trägerstützkupplung (48) verbunden ist, die sich an der dem Oberträger (20) abgewandten Seite der Stützplatte (50) befindet, drei Positionierstifte (52) umfasst.
9. Gerüstsystem, umfassend:
- Ständer (12, 112), die in regelmäßigen Abständen mit ringförmigen Rosetten (14) versehen sind, die jeweils mit Kupplungsausnehmungen (18) versehen sind;
 - Leisten (62), die an den Enden mit Leisten-Keil-Kupplungen (64) vorgesehen sind, wobei jede Leisten-Keil-Kupplung einen Körper aufweist, der mit einem Aufnahmespalt versehen ist, in dem eine ringförmige Rosette (14) aufnehmbar ist, und jede Leisten-Keil-Kupplung (64) einen Keil umfasst, der mit dem Körper der Leistenkupplung (64) beweglich verbunden ist, der durch eine Kupplungsausnehmung (18) in der ringförmigen Rosette (14) eingesetzt wer-

den kann und zur Befestigung und zum Bilden einer kraftübertragenden Verbindung zwischen der Leiste (62) und dem Ständer (12) geschlagen werden kann;

Schwenkträger (10) nach einem der vorhergehenden Ansprüche, wobei der Abstand zwischen dem Oberträger (20) und dem Unterträger (22) des Schwenkträgers (10) im Wesentlichen dem Abstand zwischen zwei benachbarten Rosetten (14 oder 14') auf den Ständern (12 oder 112) entspricht.

10. Gerüstsystem nach Anspruch 9, das ferner wenigstens einen Endträger (72) aufweist, der Folgendes umfasst:

- einen Oberträger (74), von dem sich eine Oberträgerachse (L3) in einer Endträgerenebene in einer Endträgerhaupttrichtung erstreckt;
- einen Unterträger (76), dessen Unterträgerachse (L4) sich parallel zur Endträgerhaupttrichtung in der Endträgerenebene erstreckt;
- eine Anzahl von Verbindungsrohren (78), die den Oberträger (74) und den Unterträger (76) miteinander verbinden;
- zwei Endträgerkeilkupplungen (80), die jeweils einen Körper (82) aufweisen, der mit einem ersten und einem zweiten Ende des Oberträgers (74) fest verbunden ist, wobei jeder Körper (82) mit einem Aufnahmespalt versehen ist (84), der sich senkrecht zur Endträgerenebene erstreckt, wobei jede Endträgerkeilkupplung (80) einen Keil (86) aufweist, der beweglich mit dem Körper (82) der Endträgerkeilkupplung (80) verbunden ist, wobei jede Endträgerkeilkupplung (80) eine kraftübertragende Verbindung mit einem zugeordneten Ständer (112) bereitstellt, wenn sich der Keil (86) in einem Befestigungszustand befindet;
- zwei Endträgerstützkupplungen (88), die jeweils eine sich senkrecht zur Endträgerenebene erstreckende Stützplatte (90) aufweisen, die jeweils mit einem ersten und einem zweiten Ende des Unterträgers (76) fest verbunden ist, wobei jede Endträgerstützkupplung (88) wenigstens einen Positionierstift (92) aufweist, der mit der Stützplatte (90) verbunden ist, die sich auf einer Seite der vom Oberträger (74) abgewandten Stützplatte (90) befindet.

11. Gerüstsystem nach Anspruch 10, das zum Bilden einer hängenden Bühne wenigstens Folgendes umfasst:

- zwei der Schwenkträger (10, 10') nach einem der Ansprüche 4 bis 8;
- ein Endträger wie erwähnt (72);
- ein Paar erster Ständer (12, 12'), die jeweils

entweder mit Aufhängungsmitteln oder einem Fußspindel (70) versehen sind, um den jeweiligen Ständer (12, 12') zu unterstützen, wobei mit jedem Ständer (12, 12') von dem Paar erster Ständer eine Schwenkverbinderanordnung (38, 38') eines zugeordneten Schwenkträgers (10, 10') der beiden Schwenkträger verbunden ist;

- zwei hängende Ständer (112, 112'), die mit Aufhängemitteln zum Anbringen der beiden hängenden Ständer (112, 112') an einer Überkopfkonstruktion wie einer Brücke, einem Dach oder einem Balken versehen sind,

wobei jeder der beiden hängenden Ständer (112, 112') mit der festen Trägerstützkupplung (48, 48') und der festen Trägerkeilkupplung (40, 40') eines zugeordneten Schwenkträgers (10, 10') der beiden Schwenkträger verbunden ist, wobei jedes Ende des Endträgers (72) mit einem der hängenden Ständer (112, 112') verbunden ist; und

- Bodenteile (94), die auf den beiden Schwenkträgern (10, 10') aufliegen und sich quer dazu erstrecken.

12. Gerüstsystem nach Anspruch 11, umfassend:

- eine Diagonalstrebe (96), die eine Rosette (114) eines hängenden Ständers (112) mit einer Rosette (14') eines Ständers (12') von dem Paar erster Ständer (12, 12') verbindet, und deren Länge derart ist, dass, im montierten Zustand der Diagonalstrebe (96), sich die Haupttrichtung des Oberträgers (20) des Schwenkträgers (10), der mit dem jeweiligen hängenden Ständer (112) verbunden ist, senkrecht zur Leiste (62) erstreckt, die sich zwischen den beiden Ständern (12, 12') von dem Paar erster Ständer (12, 12') erstreckt.

13. Gerüstsystem nach Anspruch 11 oder 12, wobei die Aufhängungsmittel eines hängenden Ständers (112) Folgendes umfassen:

- eine Stange (120), die mit einem Außengewinde versehen ist und sich durch den hängenden Ständer (112) erstreckt;
- eine Stützmutter (122), die im montierten Zustand eine Unterseite des hängenden Ständers (112) stützt;
- eine erste Sicherungsmutter (124), die die Position der Stützmutter (122) auf der Stange (120) sichert;
- ein drehbares Spannschloss (126), das mit einem Innengewinde versehen ist und damit mit einem oberen Ende der Stange (120) verbunden ist;
- eine zweite Sicherungsmutter (128), die die

Position des drehbaren Spanschlusses (126) an der Stange (120) sichert;
 - Befestigungsmittel (130, 132, 134), mit denen das drehbare Spanschloss (126) drehbar verbunden ist und die zum Anbringen des drehbaren Spanschlusses (126) an einer Überkopfkonstruktion wie einer Brücke oder einem Dach oder einem Balken konfiguriert sind.

14. Verfahren zum Errichten einer hängenden Bühne, umfassend:

- Bereitstellen eines Gerüstsystems nach der Kombination der Ansprüche 12 und 13;
- Stabiles Einrichten des Paares erster Ständer (12, 12') unter Verwendung entweder seiner Aufhängungsmittel oder seiner Fußspindel (70) und Verbinden der ersten Ständer (12, 12') des Paares mit wenigstens einer Leiste (62);
- Verbinden der Schwenkverbinderanordnung (38) des ersten Schwenkträgers (10) mit einem ersten (12) von dem Paar erster Ständer (12, 12');
- Anbringen eines mit Aufhängungsmitteln versehenen hängenden Ständers (112) an der festen Trägerstützkupplung (34) und der festen Trägerkeilkupplung (26) des ersten Schwenkträgers (10);
- Verbinden der Schwenkverbinderanordnung (38') des zweiten Schwenkträgers (10') mit einer zweiten (12') von dem Paar erster Ständer (12, 12');
- Anbringen eines mit Aufhängungsmitteln versehenen hängenden Ständers (112) an der festen Trägerstützkupplung (34) und der festen Trägerkeilkupplung (26) des zweiten Schwenkträgers (10);
- Herausschwenken des ersten Schwenkträgers (10) und des zweiten Schwenkträgers (10') und Platzieren der Diagonalstrebe (96) zur Befestigung des ersten Schwenkträgers (10) in einer Position, in der sich die Hauptrichtung des Oberträgers (20) des ersten Schwenkträgers (10) senkrecht zu der wenigstens einen Leiste (62) erstreckt, die die zwei Ständer (12, 12') von dem Paar erster Ständer miteinander verbindet;
- Platzieren der Bodenteile (94) auf die beiden Schwenkträger (10, 10');
- Verbinden des Endträgers (72) mit den Rosetten (114, 114') der beiden hängenden Ständer (112, 112'); und
- Anbringen der Aufhängungsmittel der beiden hängenden Ständer (112, 112') an einer Überkopfkonstruktion wie einer Brücke, einem Dach oder einem Balken.

15. Verfahren nach Anspruch 14, umfassend:

- vor dem Herausschwenken eines ersten und eines zweiten Schwenkträgers (10, 10'), die mit den hängenden Ständern (112, 112') wenigstens eine Sicherheitsleiste (140, 140') mit einer Rosette (114, 114') verbinden, die sich oberhalb der Rosetten (114, 114') befindet, mit denen der jeweilige Schwenkträger (10, 10') mit dem hängenden Ständer (112, 112') verbunden ist;
- nach dem Herausschwenken des jeweiligen Schwenkträgers (10, 10') der wenigstens eine Sicherheitsleiste (140) mit einer Rosette (14, 14') der Ständer (12, 12') von dem Paar erster Ständer (12, 12') verbindet, mit dem der jeweilige Schwenkträger (10, 10') verbunden ist.

16. Verfahren nach Anspruch 14 oder 15, umfassend:

- unmittelbar vor oder unmittelbar nach dem Platzieren des Endträgers (72), Anbringen wenigstens einer Sicherheitsleiste (142), die sich zwischen den beiden hängenden Ständern (112, 112') erstreckt und die mit den Rosetten (114, 114') der hängenden Ständer (112, 112') verbunden ist, die sich über den Rosetten (114, 114') der hängenden Ständer (112, 112') befinden, mit denen der Endträger (72) verbunden ist.

17. Verfahren nach einem der Ansprüche 14 bis 16, wobei Verbinden der Schwenkverbinderanordnung (38) des ersten Schwenkträgers (10) mit einem ersten (12) von dem Paar von Ständern (12, 12') und/oder Verbinden der Schwenkverbinderanordnung (38') des zweiten Schwenkträgers (10') mit einem zweiten (12') von dem Paar von Ständern (12, 12') Folgendes umfasst:

- Einsetzen des wenigstens einen Positionierstiftes (52) der schwenkbaren Trägerstützkupplung (48) in eine erste Rosette (14, 14') eines jeweiligen Ständers (12, 12');
- Kippen des jeweiligen Schwenkträgers (10, 10') in eine Position, in der sich die Schwenkträgerebene im Wesentlichen vertikal erstreckt und eine obere Rosette (14, 14') im Aufnahmepalt (44) der schwenkbaren Trägerkeilkupplung (40) aufgenommen wird;
- Einsetzen des Keils (46) der schwenkbaren Trägerkeilkupplung (40) durch eine Kupplungsausnehmung (18) der oberen Rosette (14) und Schlagen des Keils (46) mit Hilfe eines Hammers.

18. Verfahren nach einem der Ansprüche 14 bis 17, wobei das Verbinden des Endträgers (72) mit den Rosetten (114, 114') der zwei hängenden Ständer (112, 112') Folgendes umfasst:

- Einsetzen der Positionierstifte (92) der beiden

Endträgerstützkupplungen (88) in zwei Rosetten (114, 114') der beiden hängenden Ständer (112, 112'), die auf gleicher Höhe positioniert sind;

- Kippen des Endträgers (72) in eine Position, in der sich die Endträgerebene im Wesentlichen vertikal erstreckt und die beiden oberen Rosetten (114, 114') der jeweiligen hängenden Ständer (112, 112') in den Aufnahmespalten (84) von zwei zugeordneten Endträgerkeilkupplungen (80) aufgenommen werden;
- Einsetzen des Keils (86) jeder Endträgerkeilkupplung (80) durch eine Kupplungsausnehmung (18) der zugeordneten oberen Rosette (114, 114') und Schlagen des Keils (86) mit Hilfe eines Hammers.

Revendications

1. Poutrelle pivotante (10) destinée à être utilisée dans un système d'échafaudage du type à bague comportant des montants (12, 112) ayant, à intervalles réguliers, des rosaces en forme de bagues (14) ayant des évidements d'accouplement (18), la poutrelle pivotante (10) comprenant :

- une poutrelle supérieure (20) dont un axe de poutrelle supérieure (L1) s'étend dans un plan de poutrelle pivotante dans une direction principale de poutrelle pivotante ;
- une poutrelle inférieure (22) dont un axe de poutrelle inférieure (L2) s'étend parallèlement à la direction principale de poutrelle pivotante dans le plan de poutrelle pivotante ;
- un nombre de tubes de connexion (24) qui interconnectent la poutrelle supérieure (20) et la poutrelle inférieure (22) l'une à l'autre ;
- deux accouplements de rosace fixes (26, 34) qui sont connectés de manière fixe respectivement à une première extrémité de la poutrelle supérieure (20) et à une première extrémité de la poutrelle inférieure (22) ;
- un ensemble de connecteur pivotant (38) qui comprend deux accouplements de rosace pivotables (40, 48) qui sont connectés respectivement à une deuxième extrémité de la poutrelle supérieure (20) et à une deuxième extrémité de la poutrelle inférieure (22) de manière pivotable autour d'un axe de pivotement (S) ;

caractérisée en ce que

- un accouplement inférieur parmi les deux accouplements de rosace pivotables (40, 48) est un accouplement de support de poutrelle pivotable (48) qui comporte une plaque de support (50) s'étendant perpendiculairement au plan de

poutrelle pivotante et à l'axe de pivotement (S) qui est connectée à la deuxième extrémité de la poutrelle inférieure (22) de manière pivotable autour de l'axe de pivotement (S), dans lequel l'accouplement de support de poutrelle pivotable (48) comporte au moins un ergot de positionnement (52) connecté à la plaque de support (50), qui se trouve sur un côté de la plaque de support (50) qui n'est pas orienté vers la poutrelle supérieure (20) ;

dans laquelle l'ensemble de connecteur pivotant (38) comprend en outre :

- une tige de connexion (54) qui relie les deux accouplements de rosace pivotables (40, 48) l'un à l'autre, de sorte que les deux accouplements de rosace pivotables (40, 48) ont toujours la même position pivotée autour de l'axe de pivotement (S) par rapport au plan de poutrelle pivotante.

2. Poutrelle pivotante (10) selon la revendication 1, dans laquelle un accouplement supérieur parmi les deux accouplements de rosace pivotables (40, 48) est un accouplement à coin de poutrelle pivotable (40) qui comporte un corps (42) qui est connecté à une deuxième extrémité de la poutrelle supérieure (20) de manière pivotable autour d'un axe de pivotement, dans laquelle l'axe de pivotement (S) s'étend dans le plan de poutrelle pivotante et s'étend perpendiculairement à l'axe de poutrelle supérieure (L1), dans laquelle le corps (42) de l'accouplement à coin de poutrelle pivotable (40) est pourvu d'un espace récepteur (44) qui s'étend perpendiculairement au plan de poutrelle pivotante et à l'axe de pivotement (S), et dans laquelle l'accouplement à coin de poutrelle pivotable (40) comporte un coin (46) qui est connecté de manière mobile au corps (42) de l'accouplement à coin de poutrelle pivotable (40), dans laquelle l'accouplement à coin de poutrelle pivotable (40) fournit une connexion à transmission de force avec un montant (12) quand le coin (46) est dans un état de fixation.

3. Poutrelle pivotante selon la revendication 2,

dans laquelle un accouplement inférieur parmi les deux accouplements de rosace fixes (26, 34) est un accouplement de support de poutrelle fixe (34) qui comporte une plaque de support (36) s'étendant perpendiculairement au plan de poutrelle pivotante, qui est connectée de manière fixe à une première extrémité de la poutrelle inférieure (22), dans laquelle l'accouplement de support de poutrelle (34) comporte au moins un ergot de positionnement (38) connecté à la plaque de support, qui est du côté de la plaque de

- support (36) qui n'est pas orienté vers une poutrelle supérieure (20) ; et
 dans laquelle un accouplement supérieur parmi les deux accouplements de rosace fixes (26, 34) est un accouplement à coin de poutrelle fixe (26) qui comporte un corps (28) qui est connecté de manière fixe à une première extrémité de la poutrelle supérieure (20), dans laquelle le corps (28) est pourvu d'un espace récepteur (30) qui s'étend perpendiculairement au plan de poutrelle pivotante, dans laquelle l'accouplement à coin de poutrelle fixe (26) comporte un coin (32) qui est connecté de manière mobile au corps (28) de l'accouplement à coin de poutrelle fixe (26), dans laquelle l'accouplement à coin de poutrelle fixe (26) fournit une connexion de transmission à transmission de force avec un montant (12) quand le coin (32) est dans un état de fixation.
4. Poutrelle pivotante selon la revendication 2 ou 3, dans laquelle l'accouplement à coin de poutrelle pivotable (40) comprend un support en U (56) comportant deux branches de support (56a) et un corps de support (56b), le corps de support (56b) étant connecté de manière fixe au corps (42) de l'accouplement à coin de poutrelle pivotable (40), dans laquelle l'accouplement de support de poutrelle pivotable (48) comprend un support en U (58) comportant deux branches de support (58a) et un corps de support (58b), le corps de support (58b) étant connecté de manière fixe à la plaque de support (50) de l'accouplement de support de poutrelle pivotable (48), dans laquelle la tige de connexion (54) interconnecte les deux supports en U (56, 58).
5. Poutrelle pivotante selon la revendication 4, dans laquelle la poutrelle supérieure (20) et la poutrelle inférieure (22) sont tubulaires, dans laquelle la deuxième extrémité de la poutrelle supérieure (20) est reçue entre les branches (56a) du support en U (56) de l'accouplement à coin de poutrelle pivotable (40), dans laquelle la deuxième extrémité de la poutrelle inférieure (22) est reçue entre les branches (58a) du support en U (58) de l'accouplement de support de poutrelle pivotable (48), dans laquelle les deux deuxièmes extrémités de la poutrelle supérieure (20) et de la poutrelle inférieure (22) sont pourvues chacune d'un trou qui forme un passage, dans laquelle l'ensemble de connecteur pivotant (38) comprend un axe d'articulation (60) qui s'étend le long de l'axe de pivotement (S) à travers les branches de support (56a, 58a) et les passages des deux deuxièmes extrémités pour former les connexions pivotables entre le corps (42) de l'accouplement à coin de poutrelle pivotable (40) et la poutrelle supérieure (20) et entre la plaque de support (50) de l'accouplement de support de poutrelle pivotable (48) et la poutrelle inférieure (22).
6. Poutrelle pivotante selon la revendication 5, dans laquelle l'axe d'articulation (60) s'étend à travers la tige de connexion (54) qui relie l'accouplement à coin de poutrelle pivotable (40) à l'accouplement de support de poutrelle pivotable (48).
7. Poutrelle pivotante selon la revendication 3 ou selon les revendications 4 à 6 lorsqu'elles dépendent de la revendication 3, dans laquelle ledit au moins un ergot de positionnement (38) connecté à la plaque de support (36) de l'accouplement de support de poutrelle fixe (34), qui se trouve du côté de la plaque de support (36) qui n'est pas orienté vers la poutrelle supérieure (20), comprend trois ergots de positionnement (38).
8. Poutrelle pivotante selon l'une quelconque des revendications 2 à 7, dans laquelle ledit au moins un ergot de positionnement (52) connecté à la plaque de support (50) de l'accouplement de support de poutrelle pivotable (48), qui se trouve du côté de la plaque de support (50) qui n'est pas orienté vers la poutrelle supérieure (20), comprend trois ergots de positionnement (52).
9. Système d'échafaudage comprenant :
- des montants (12, 112) qui sont pourvus, à intervalles réguliers, de rosaces en forme de bagues (14) qui comportent des évidements d'accouplement (18) ;
 - des solives (62) qui sont pourvues aux extrémités d'accouplements à coin de solive (64), chaque accouplement à coin de solive comprenant un corps qui est pourvu d'un espace récepteur dans lequel peut être reçue une rosace en forme de bague (14) et chaque accouplement à coin de solive (64) comportant un coin qui est connecté de manière mobile au corps de l'accouplement de solive (64) et qui peut être inséré dans un évidement d'accouplement (18) formé dans la rosace en forme de bague (14) et qui peut être frappé pour être fixé et pour former une connexion à transmission de force entre la solive (62) et le montant (12) ;
 - des poutrelles pivotantes (10) selon l'une quelconque des revendications précédentes, dans lequel la distance qui sépare la poutrelle supérieure (20) de la poutrelle inférieure (22) de la poutrelle pivotante (10) correspond substantiel-

lement à la distance qui sépare deux rosaces voisines (14 ou 14') sur les montants (12 ou 112).

10. Système d'échafaudage selon la revendication 9, comportant en outre au moins une poutrelle d'extrémité (72) qui comprend :

- une poutrelle supérieure (74) dont un axe de poutrelle supérieure (L3) s'étend dans un plan de poutrelle d'extrémité dans une direction principale de poutrelle d'extrémité ;
- une poutrelle inférieure (76) dont un axe de poutrelle inférieure (L4) s'étend parallèlement à la direction principale de poutrelle d'extrémité dans le plan de poutrelle d'extrémité ;
- un nombre de tubes de connexion (78) qui interconnectent la poutrelle supérieure (74) et la poutrelle inférieure (76) l'une avec l'autre ;
- deux accouplements à coin de poutrelle d'extrémité (80) qui comportent chacun un corps (82) qui est connecté de manière fixe respectivement à une première et à une deuxième extrémité de la poutrelle supérieure (74), dans lequel chaque corps (82) est pourvu d'un espace récepteur (84) qui s'étend perpendiculairement au plan de poutrelle d'extrémité, dans lequel chaque accouplement à coin de poutrelle d'extrémité (80) comporte un coin (86) qui est connecté de façon mobile au corps (82) de l'accouplement à coin de poutrelle d'extrémité (80), dans lequel chaque accouplement à coin de poutrelle d'extrémité (80) fournit une connexion à transmission de force avec un montant associé (112) quand le coin (86) est dans un état de fixation ;
- deux accouplements de support de poutrelle d'extrémité (88) qui comportent chacun une plaque de support (90) s'étendant perpendiculairement au plan de poutrelle d'extrémité, qui est connectée de manière fixe respectivement à une première et une deuxième extrémité de la poutrelle inférieure (76), dans lequel chaque accouplement de support de poutrelle d'extrémité (88) comporte au moins un ergot de positionnement (92) connecté à la plaque de support (90), qui se trouve sur un côté de la plaque de support (90) qui n'est pas orienté vers la poutrelle supérieure (74).

11. Système d'échafaudage selon la revendication 10, qui pour former une plate-forme suspendue comprend au moins :

- deux desdites poutrelles pivotantes (10, 10') selon l'une quelconque des revendications 4 à 8 ;
- une poutrelle d'extrémité telle que mentionnée

(72) ;

- une paire de premiers montants (12, 12') qui sont pourvus chacun soit d'un moyen de suspension, soit d'un vérin de base (70) pour supporter le montant respectif (12, 12'), un ensemble de connecteur pivotant (38, 38') d'une poutrelle pivotante associée (10, 10') parmi les deux poutrelles pivotantes étant connecté à chaque montant (12, 12') de la paire de premiers montants ;
- deux montants suspendus (112, 112') pourvus d'un moyen de suspension pour fixer les deux montants suspendus (112, 112') sur une construction en hauteur, telle qu'un pont, un toit ou une poutre,

dans lequel chacun des deux montants suspendus (112, 112') est connecté à l'accouplement de support de poutrelle fixe (48, 48') et à l'accouplement à coin de poutrelle fixe (40, 40') d'une poutrelle pivotante associée (10, 10') parmi lesdites deux poutrelles pivotantes, dans lequel chaque extrémité de la poutrelle d'extrémité (72) est connectée à l'un desdits montants suspendus (112, 112') ; et

- des parties de plancher (94) qui reposent sur et s'étendent transversalement aux deux poutrelles pivotantes (10, 10').

12. Système d'échafaudage selon la revendication 11, comprenant :

- une contrefiche diagonale (96) qui relie une rosace (114) d'un montant suspendu (112) à une rosace (14') d'un montant (12') de ladite paire de premiers montants (12, 12'), et dont la longueur est telle que dans l'état monté de la contrefiche diagonale (96), la direction principale de la poutrelle supérieure (20) de la poutrelle pivotante (10) qui est connectée au montant suspendu respectif (112) s'étend perpendiculairement à la solive (62) qui s'étend entre les deux montants (12, 12') de la paire de premiers montants (12, 12').

13. Système d'échafaudage selon la revendication 11 ou 12, dans lequel le moyen de suspension d'un montant suspendu (112) comprend :

- une tige (120) qui est pourvue d'un filetage extérieur et qui s'étend à travers le montant suspendu (112) ;
- un écrou de support (122) qui, dans l'état monté, supporte une face inférieure du montant suspendu (112) ;
- un premier contre-écrou (124) qui bloque la position de l'écrou de support (122) sur la tige

(120) ;

- un tendeur à vis rotatif (126) qui est pourvu d'un filetage intérieur avec lequel il est connecté à une extrémité supérieure de la tige (120) ;
- un deuxième contre-écrou (128) qui bloque la position du tendeur à vis rotatif (126) sur la tige (120) ;
- un moyen de fixation (130, 132, 134) avec lequel le tendeur à vis rotatif (126) est connecté à rotation et qui est configuré pour la fixation du tendeur à vis rotatif (126) sur une construction en hauteur, telle qu'un pont, un toit ou une poutre.

14. Procédé pour ériger une plateforme suspendue, comprenant les étapes suivantes :

- fournir un système d'échafaudage selon la combinaison des revendications 12 et 13 ;
- monter de manière stable la paire de premiers montants (12, 12') en utilisant soit leurs moyens de suspension, soit leurs vérins de base (70) et en interconnectant les premiers montants (12, 12') de la paire avec au moins une solive (62) ;
- connecter l'ensemble de connecteur pivotant (38) de la première poutrelle pivotante (10) avec un premier montant (12) de la paire de premiers montants (12, 12') ;
- fixer un montant suspendu (112) pourvu d'un moyen de suspension à l'accouplement de support de poutrelle fixe (34) et à l'accouplement à coin de poutrelle fixe (26) de la première poutrelle pivotante (10) ;
- connecter l'ensemble de connecteur pivotant (38') de la deuxième poutrelle pivotante (10') avec un deuxième montant (12') de la paire de premiers montants (12, 12') ;
- fixer un montant suspendu (112') pourvu d'un moyen de suspension à l'accouplement de support de poutrelle fixe (34') et à l'accouplement à coin de poutrelle fixe (26') de la deuxième poutrelle pivotante (10') ;
- déployer la première poutrelle pivotante (10) et la deuxième poutrelle pivotante (10'), puis placer la contrefiche diagonale (96) pour fixer la première poutrelle pivotante (10) dans une position dans laquelle la direction principale de la poutrelle supérieure (20) de la première poutrelle pivotante (10) s'étend perpendiculairement à ladite au moins une solive (62) qui relie les deux montants (12, 12') de la paire de premiers montants l'un à l'autre ;
- mettre en place les parties de plancher (94) sur les deux poutrelles pivotantes (10, 10') ;
- connecter la poutrelle d'extrémité (72) aux rosaces (114, 114') des deux montants suspendus (112, 112') ; et
- fixer le moyen de suspension des deux mon-

tants suspendus (112, 112') à une construction en hauteur, telle qu'un pont, un toit ou une poutre.

15. Procédé selon la revendication 14, comprenant les étapes suivantes :

- avant le déploiement d'une première et d'une deuxième poutrelle pivotante (10, 10'), connecter avec les montants suspendus (112, 112') au moins une solive de sécurité (140, 140') à une rosace (114, 114') qui se trouve au-dessus des rosaces (114, 114') avec lesquelles la poutrelle pivotante respective (10, 10') est connectée au montant suspendu (112, 112') ;
- après le déploiement de la poutrelle pivotante respective (10, 10'), connecter ladite au moins une solive de sécurité (140) à une rosace (14, 14') du montant (12, 12') de la paire de premiers montants (12, 12') auquel la poutrelle pivotante respective (10, 10') est connectée.

16. Procédé selon la revendication 14 ou 15, comprenant l'étape suivante :

- directement avant ou directement après la mise en place de la poutrelle d'extrémité (72), fixer au moins une solive de sécurité (142) qui s'étend entre les deux montants suspendus (112, 112') et qui est connectée aux rosaces (114, 114') des montants suspendus (112, 112') qui sont au-dessus des rosaces (114, 114') des montants suspendus (112, 112') auxquels la poutrelle d'extrémité (72) est connectée.

17. Procédé selon l'une quelconque des revendications 14 à 16, dans lequel la connexion de l'ensemble de connecteur pivotant (38) de la première poutrelle pivotante (10) avec un premier montant (12) de la paire de montants (12, 12') et/ou la connexion de l'ensemble de connecteur pivotant (38') de la deuxième poutrelle pivotante (10') avec un deuxième montant (12') de la paire de montants (12, 12') comprend les opérations suivantes :

- insérer ledit au moins un ergot de positionnement (52) de l'accouplement de support de poutrelle pivotante (48) dans une première rosace (14, 14') d'un montant respectif (12, 12') ;
- incliner la poutrelle pivotante respective (10, 10') dans une position dans laquelle le plan de poutrelle pivotante s'étend substantiellement verticalement et une rosace supérieure (14, 14') est reçue dans l'espace récepteur (44) de l'accouplement à coin de poutrelle pivotante (40) ;
- insérer le coin (46) de l'accouplement à coin de poutrelle pivotante (40) dans un évidement d'accouplement (18) de la rosace supérieure

(14) puis frapper le coin (46) à l'aide d'un marteau.

18. Procédé selon l'une quelconque des revendications 14 à 17, dans lequel la connexion de la poutrelle d'extrémité (72) aux rosaces (114, 114') des deux montants suspendus (112, 112') comprend les opérations suivantes :

- insérer les ergots de positionnement (92) des deux accouplements de support de poutrelle d'extrémité (88) dans deux rosaces (114, 114') des deux montants suspendus (112, 112') qui sont positionnés à un niveau égal ;

- incliner la poutrelle d'extrémité (72) dans une position dans laquelle le plan de poutrelle d'extrémité s'étend substantiellement verticalement et les deux rosaces supérieures (114, 114') des montants suspendus respectifs (112, 112') sont reçues dans les espaces récepteurs (84) de deux accouplements à coin de poutrelle d'extrémité (80) associés ;

- insérer le coin (86) de chaque accouplement à coin de poutrelle d'extrémité (80) dans un évidement d'accouplement (18) de la rosace supérieure associée (114, 114') puis frapper le coin (86) à l'aide d'un marteau.

30

35

40

45

50

55

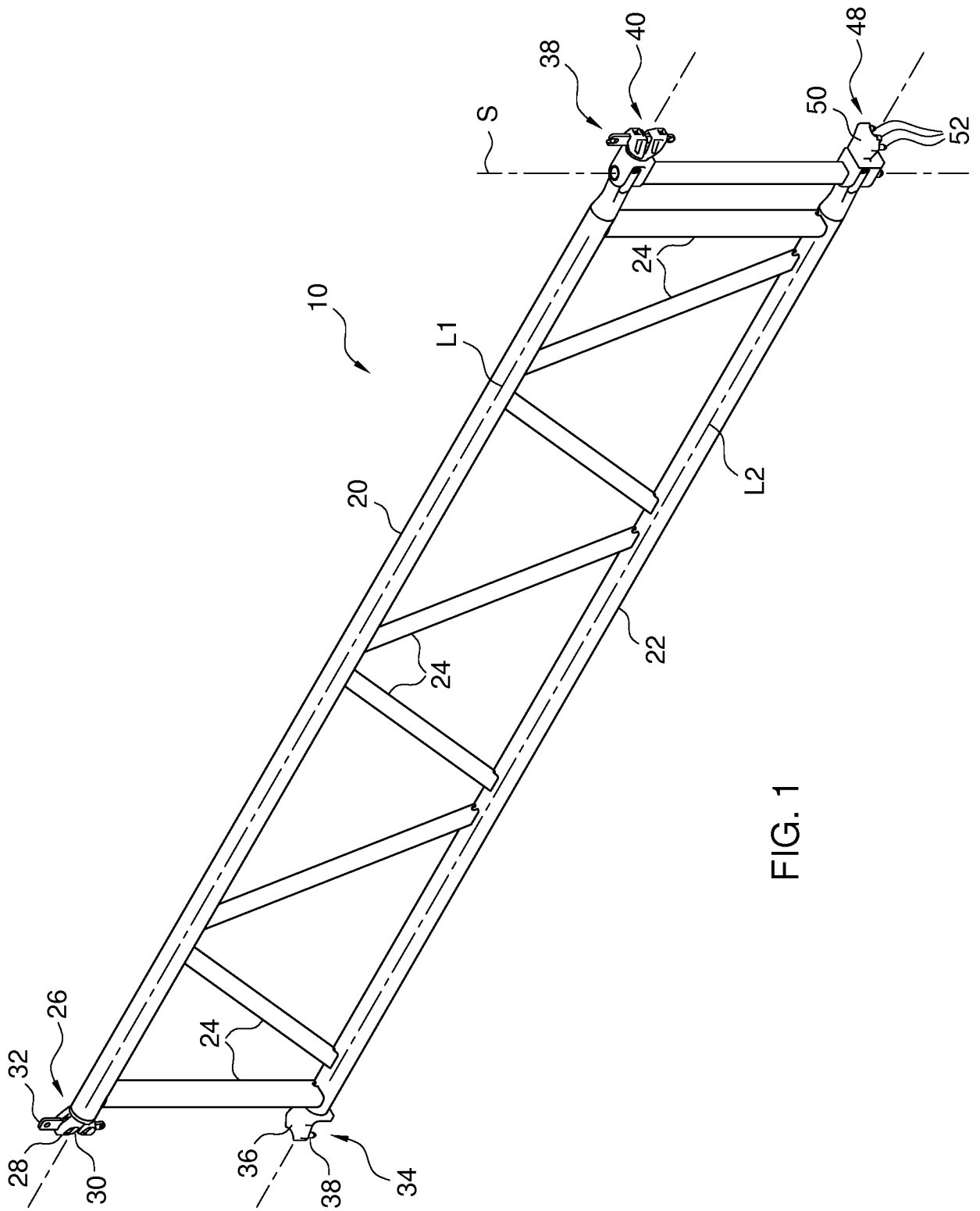

FIG. 1

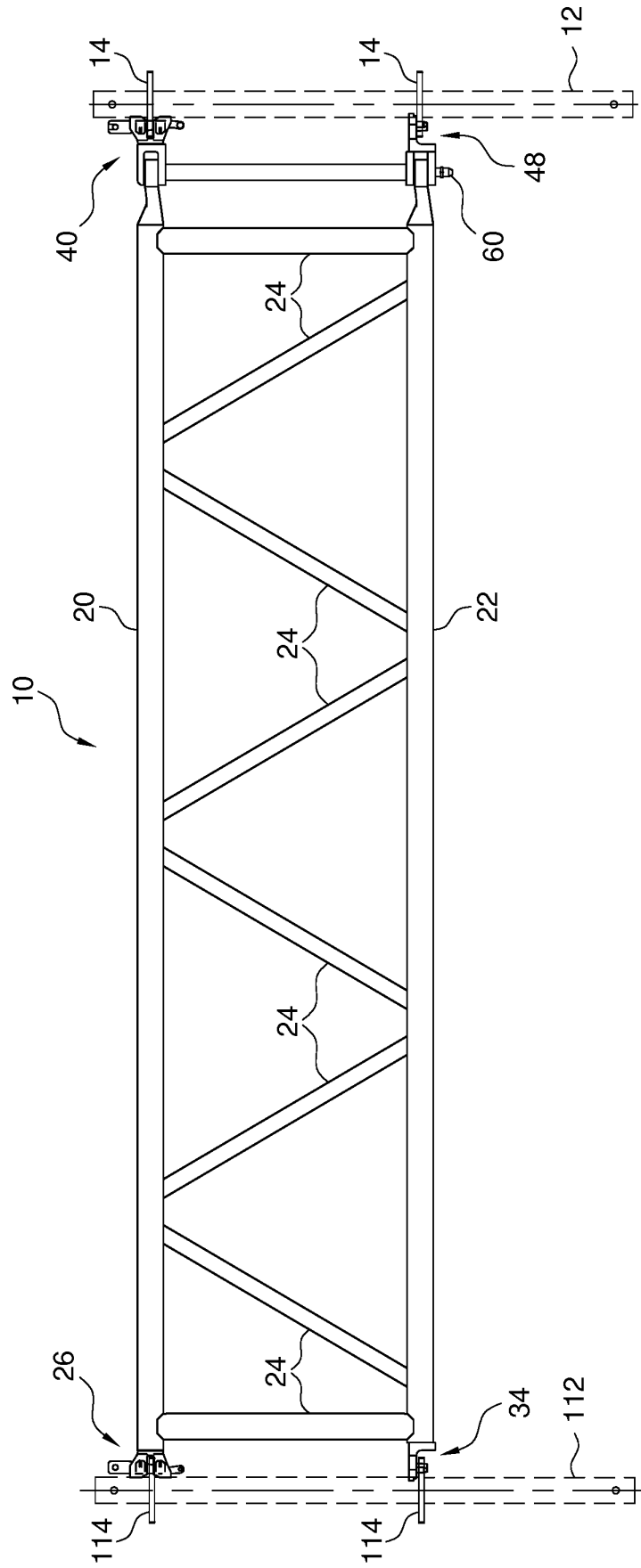

FIG. 2

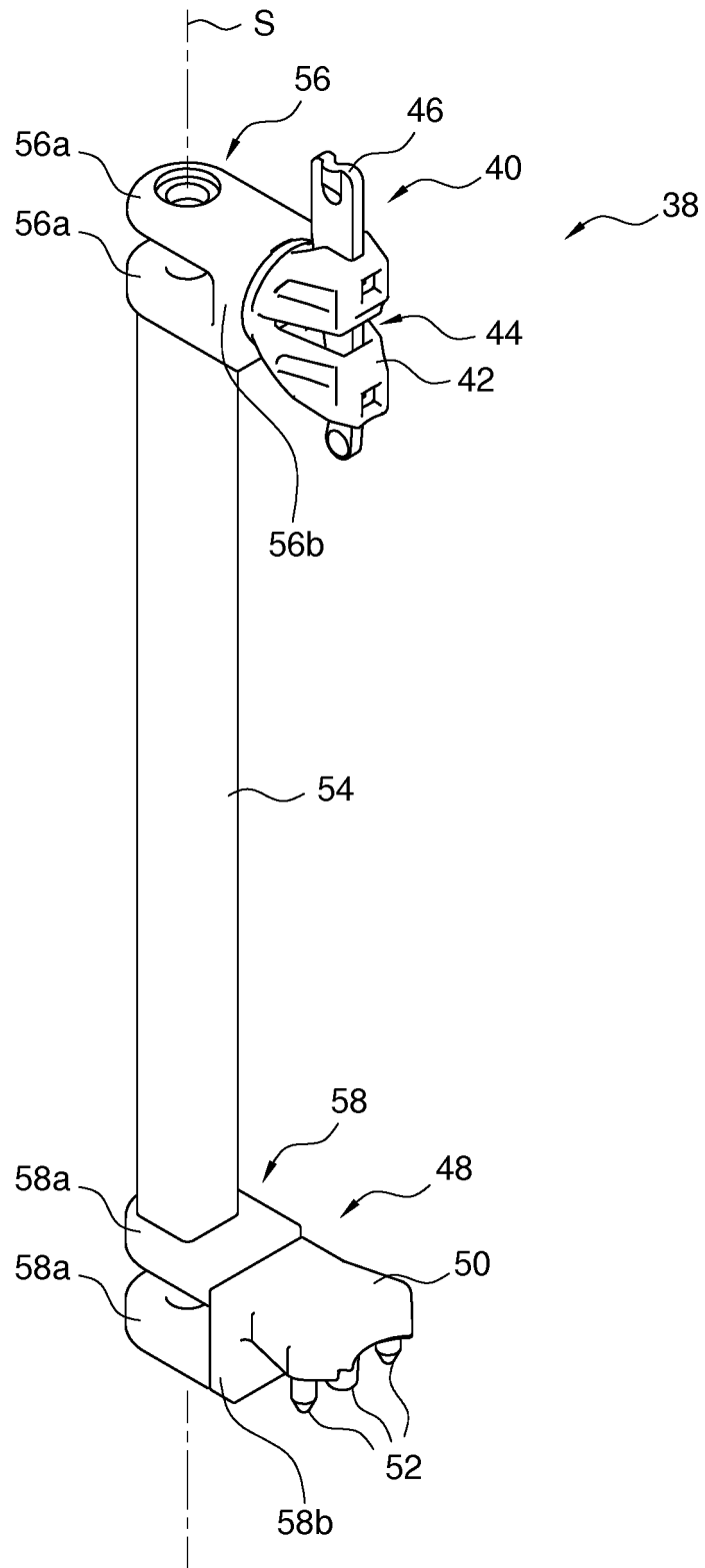

FIG. 3

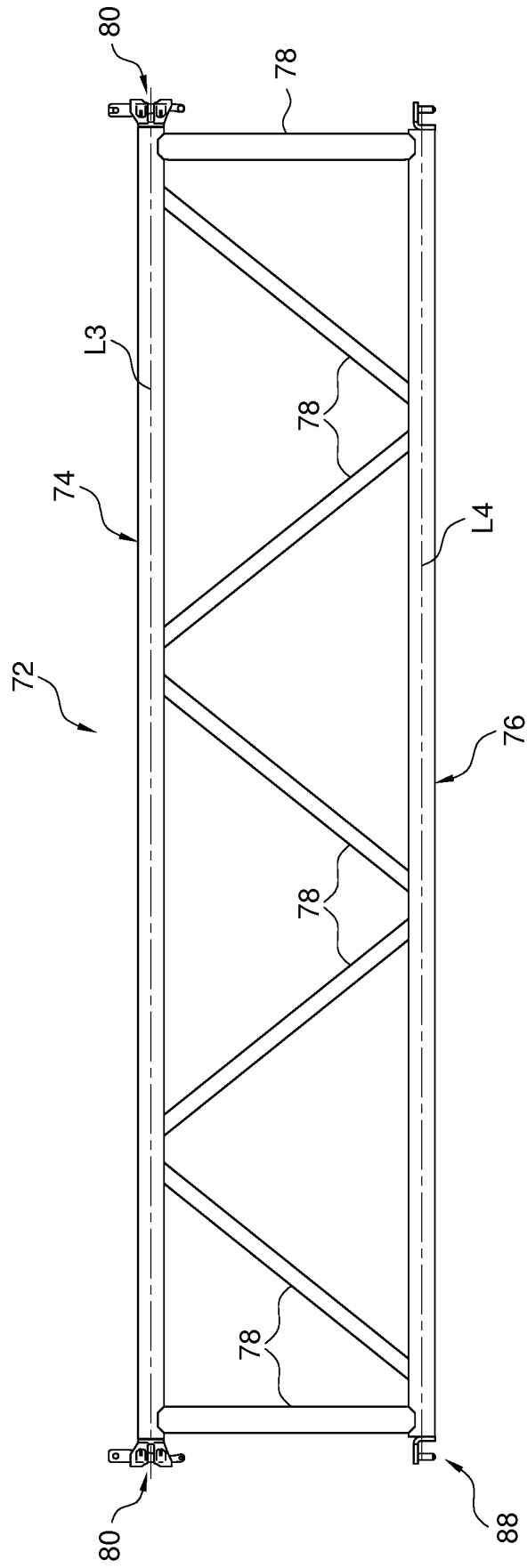

FIG. 4

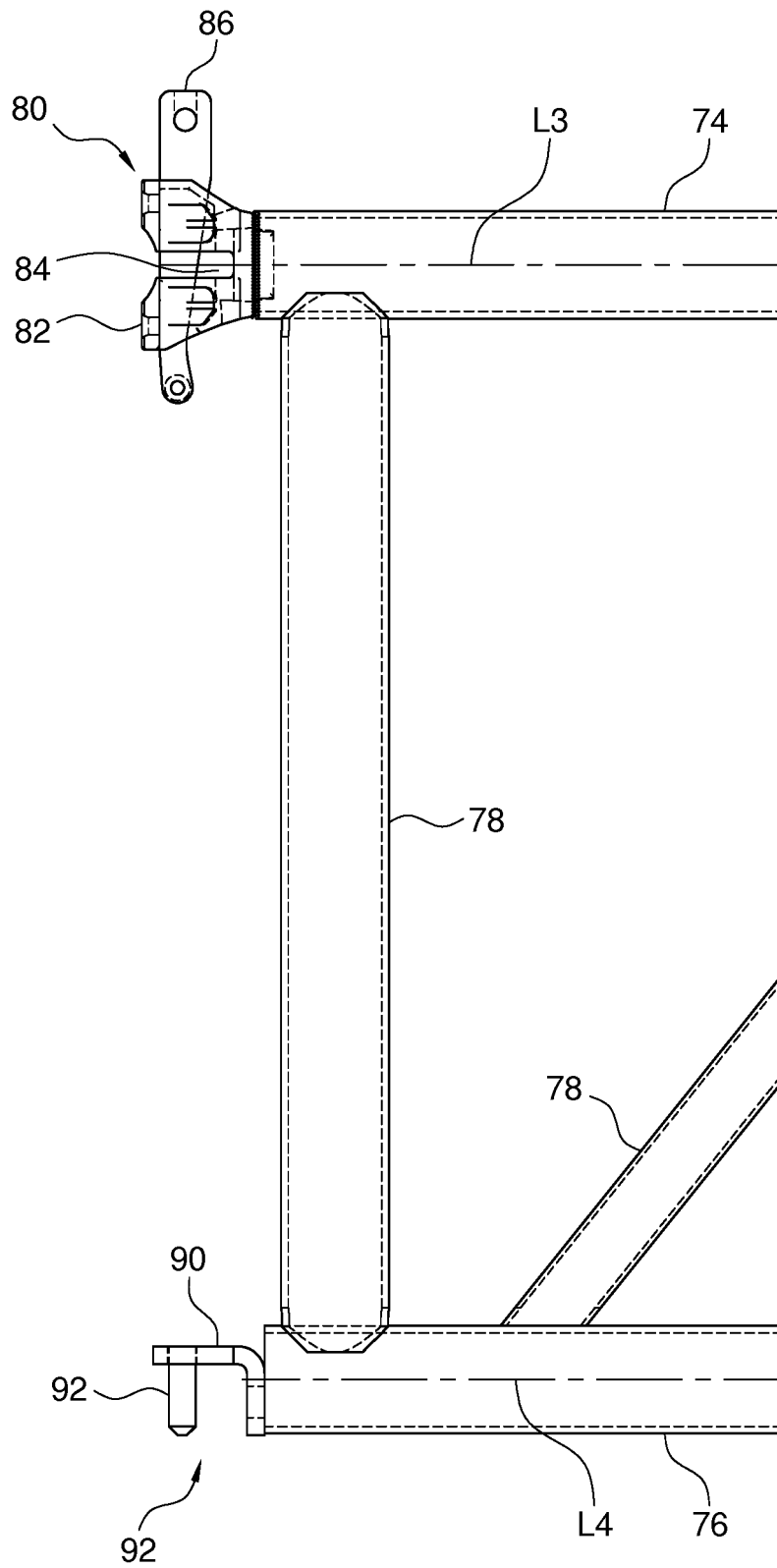

FIG. 5

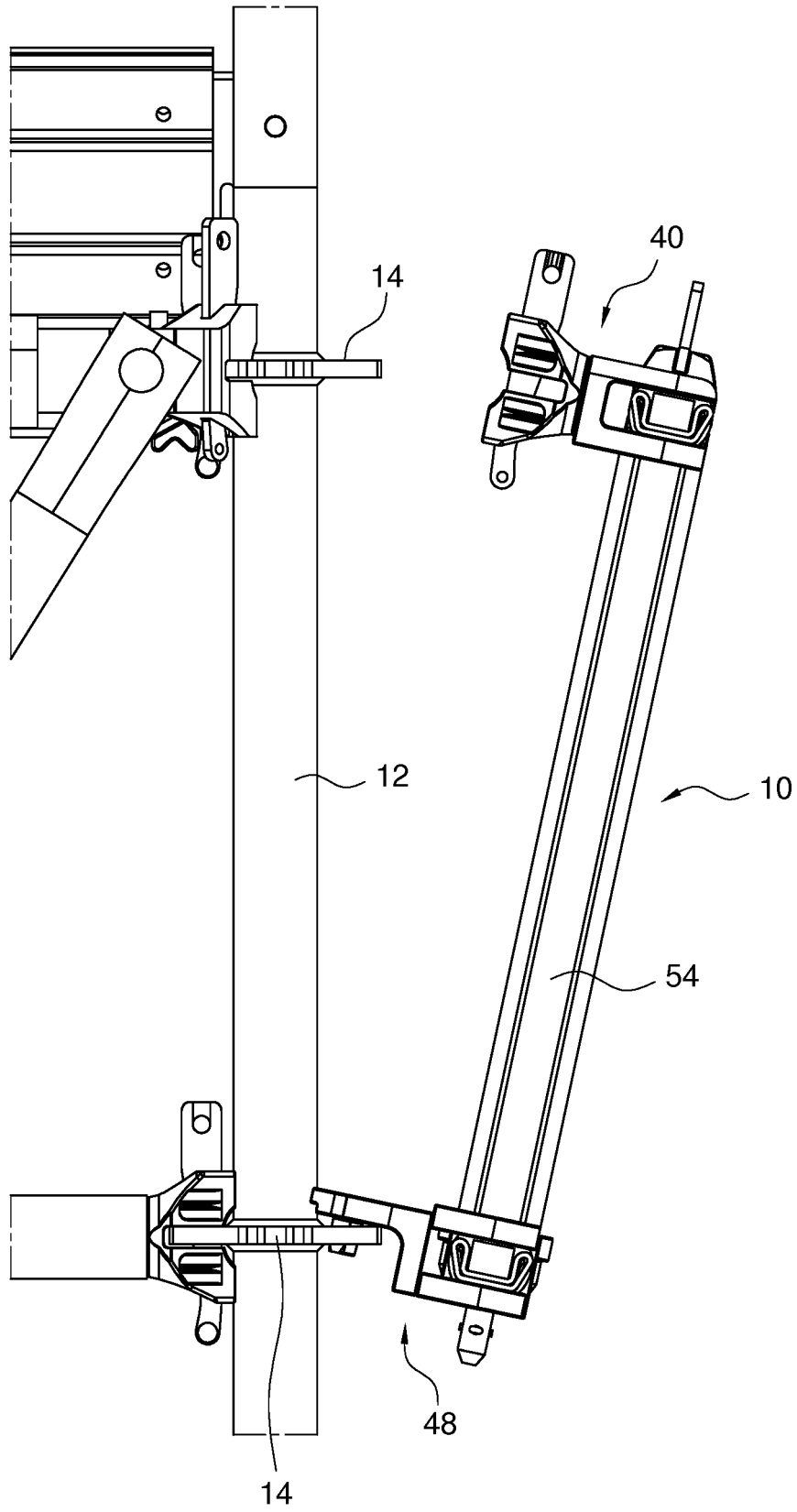

FIG. 6

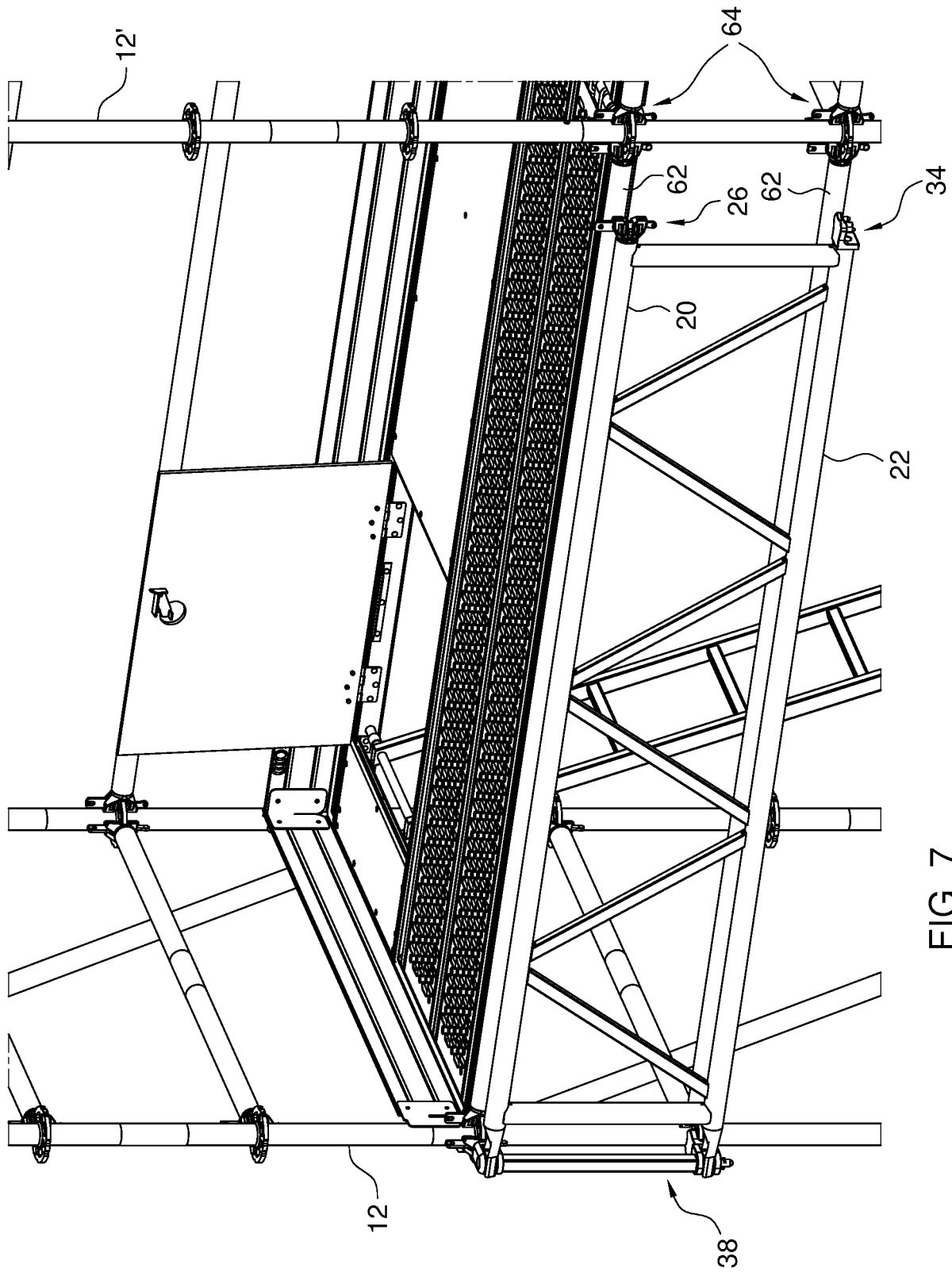

FIG. 7

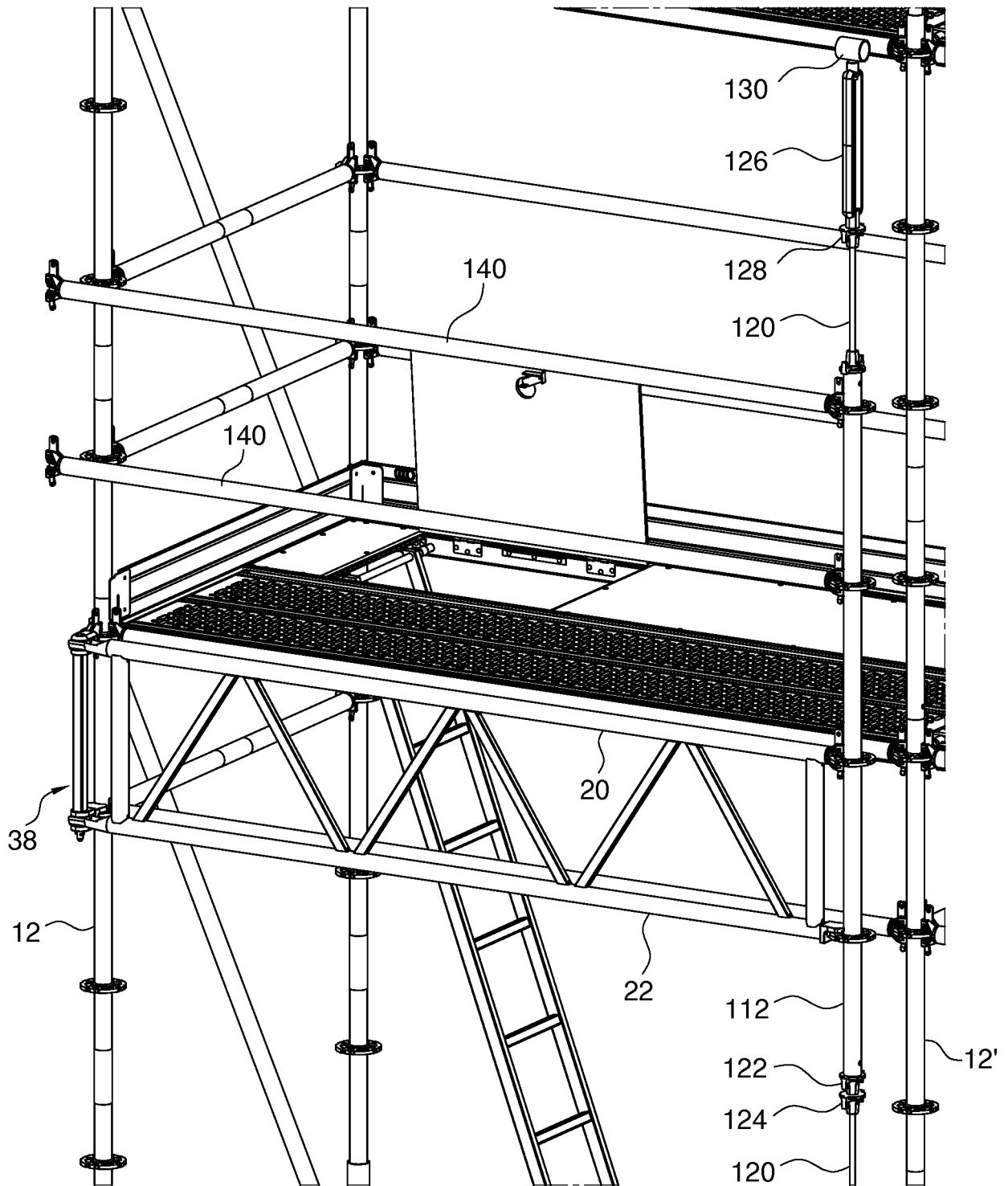

FIG. 8

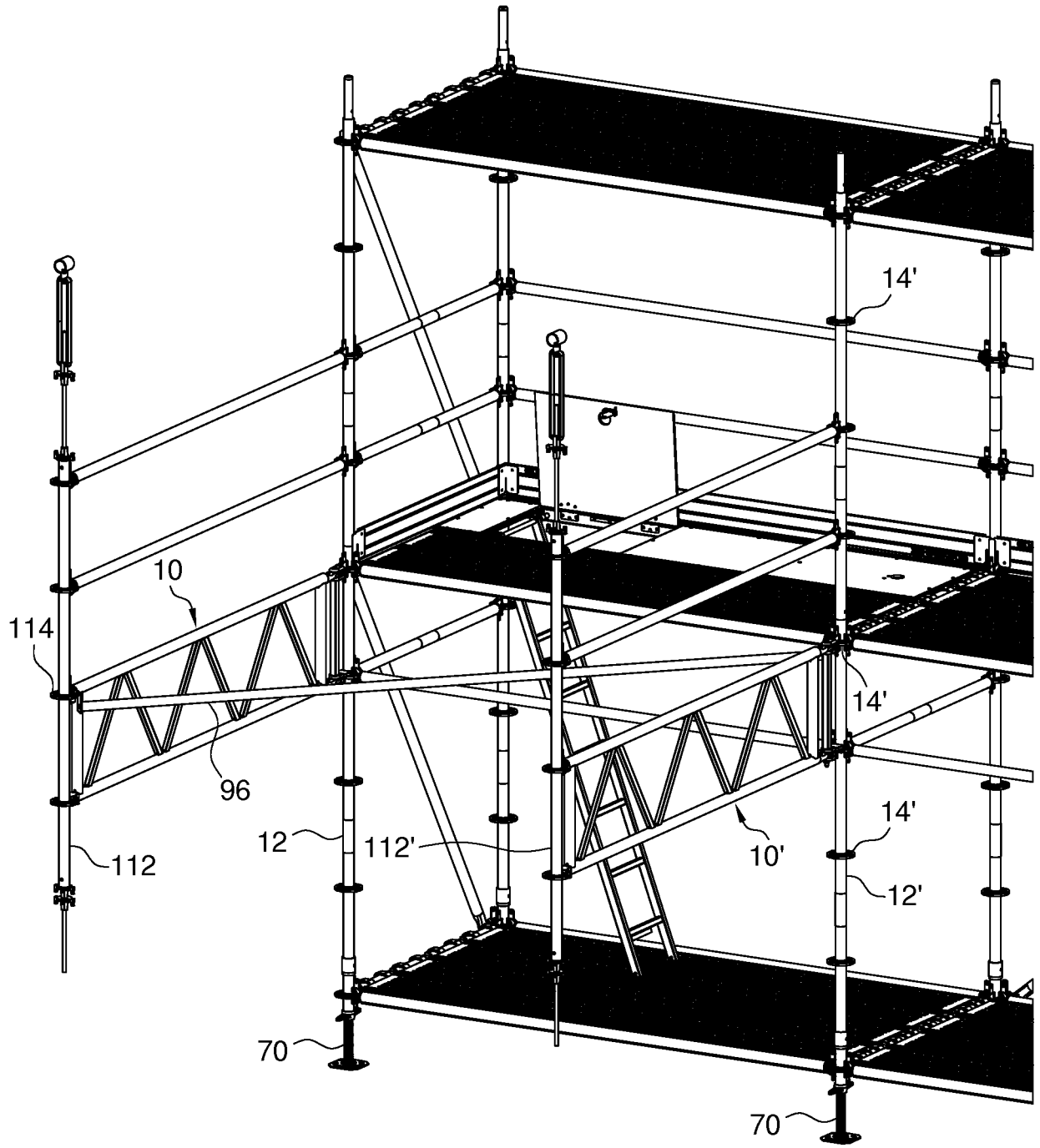

FIG. 9

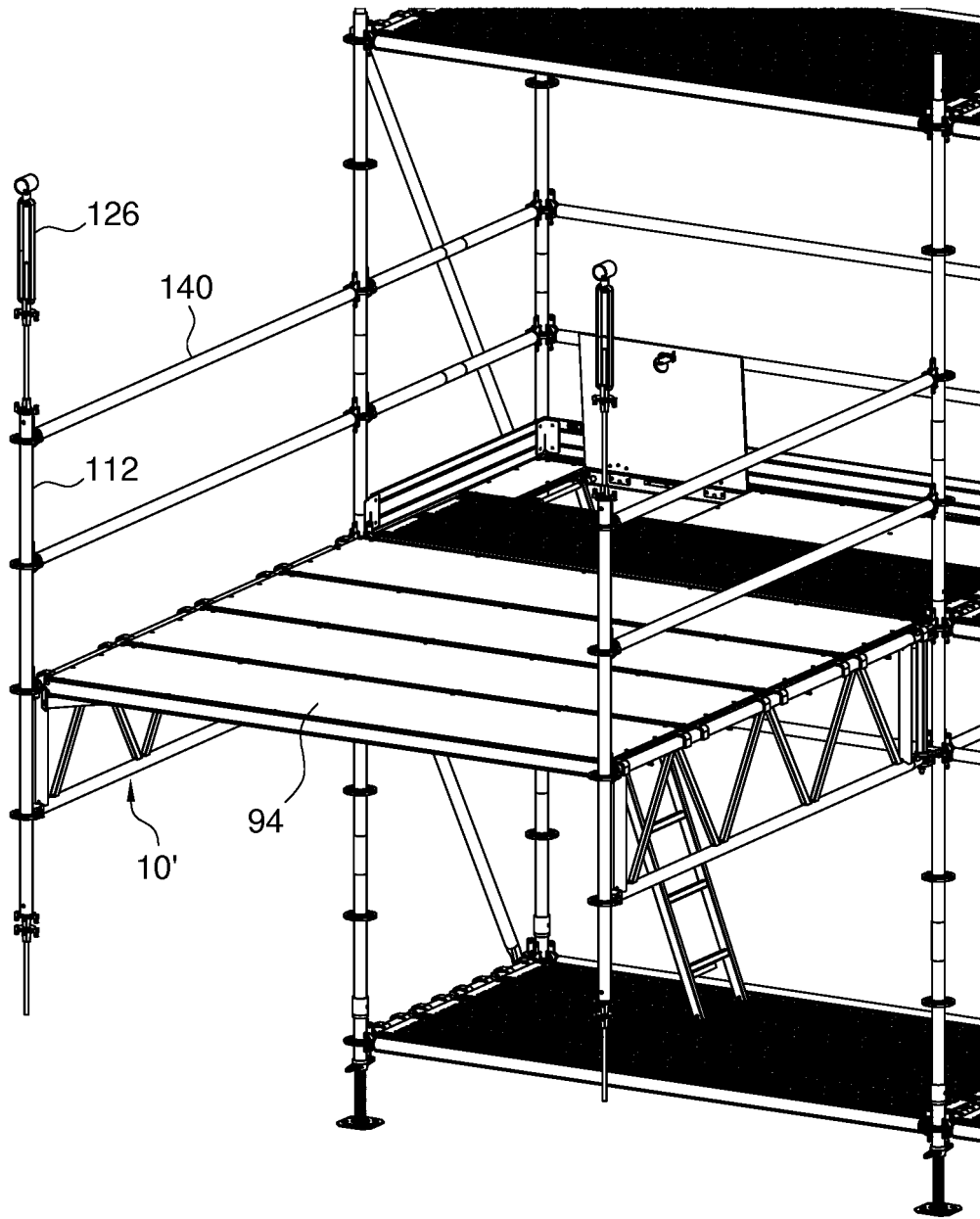

FIG. 10

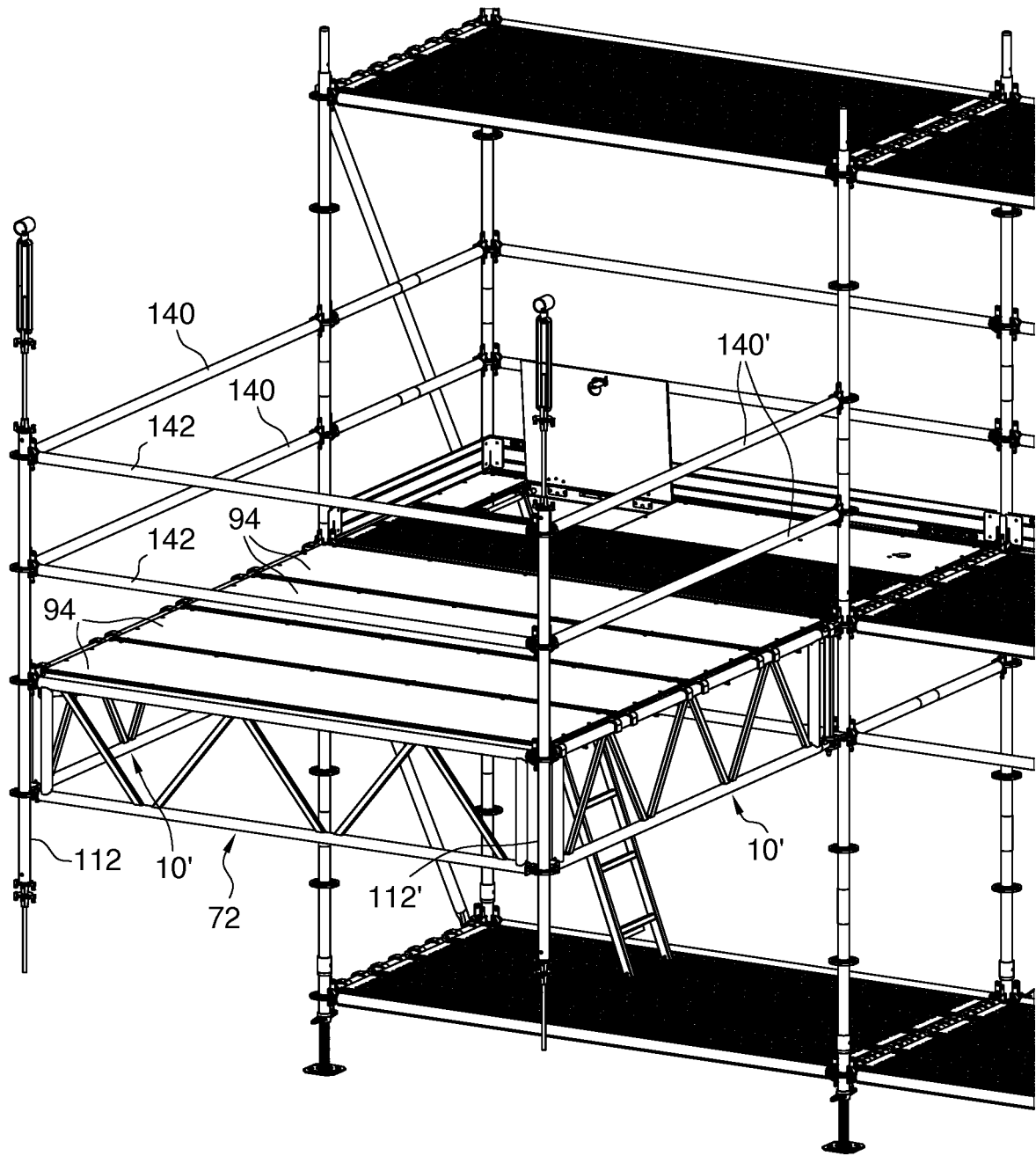

FIG. 11

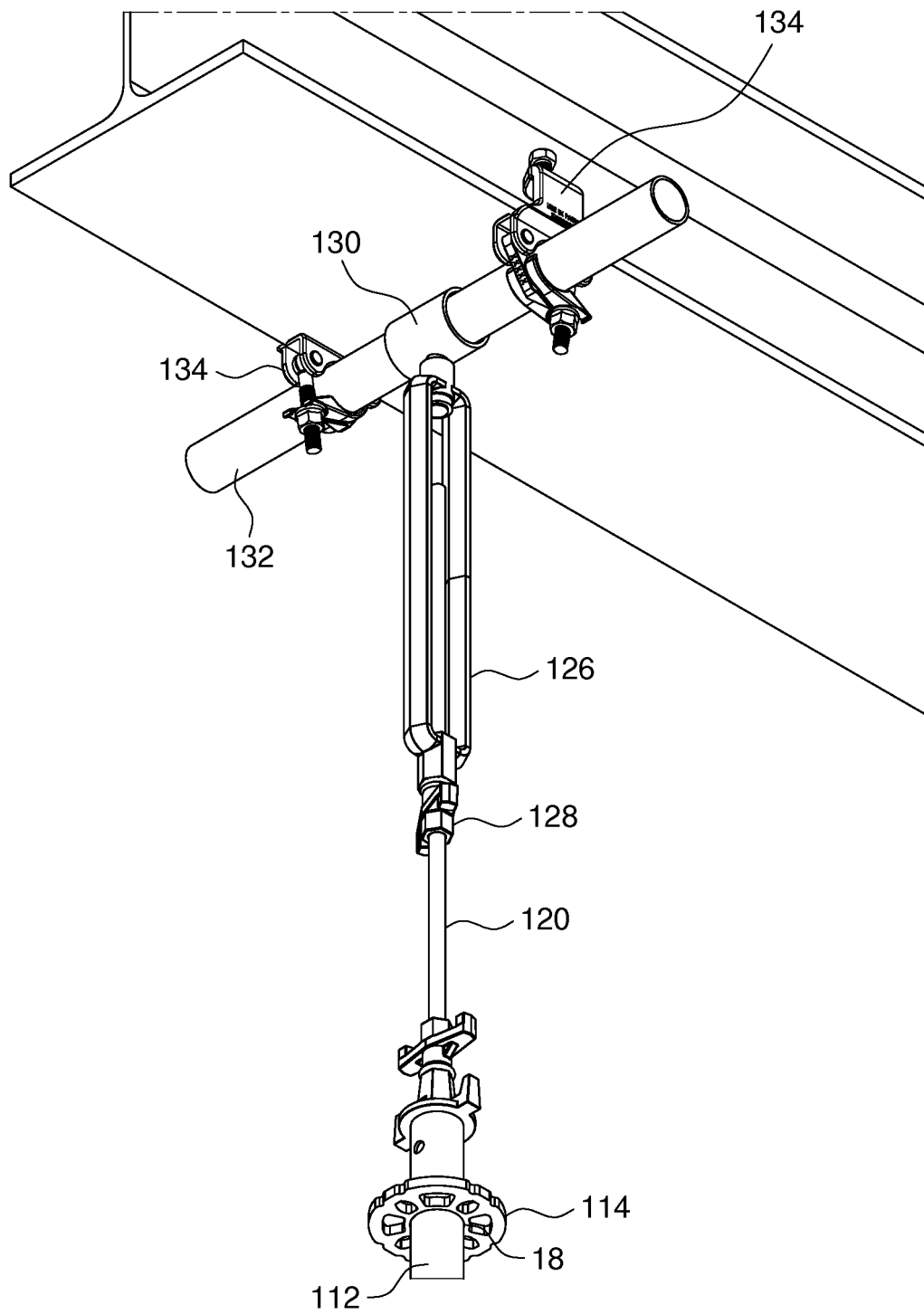

FIG. 12

REFERENCES CITED IN THE DESCRIPTION

This list of references cited by the applicant is for the reader's convenience only. It does not form part of the European patent document. Even though great care has been taken in compiling the references, errors or omissions cannot be excluded and the EPO disclaims all liability in this regard.

Patent documents cited in the description

- CA 02740549 [0003]
- WO 2013066859 A1 [0004] [0011]

Non-patent literature cited in the description

- The Ringscaff erection manual complete. May 2011 [0002]