

(19) World Intellectual Property Organization
International Bureau



(43) International Publication Date
1 September 2011 (01.09.2011)

(10) International Publication Number
WO 2011/106327 A2

(51) International Patent Classification:
G01B 11/24 (2006.01) **G01N 21/00** (2006.01)

[SG/US]; 1269 E. Elizabeth St., Pasadena, California 91104 (US). **WU, Jigang** [CN/US]; 301 Verano Place, Irvine, CA 92617 (US).

(21) International Application Number:
PCT/US2011/025762

(74) Agent: **MARTINEZ-LEMKE, Sheila**; 110 Pacific Avenue, Suite 240, San Francisco, California 94111 (US).

(22) International Filing Date:
22 February 2011 (22.02.2011)

(81) Designated States (unless otherwise indicated, for every kind of national protection available): AE, AG, AL, AM, AO, AT, AU, AZ, BA, BB, BG, BH, BR, BW, BY, BZ, CA, CH, CL, CN, CO, CR, CU, CZ, DE, DK, DM, DO, DZ, EC, EE, EG, ES, FI, GB, GD, GE, GH, GM, GT, HN, HR, HU, ID, IL, IN, IS, JP, KE, KG, KM, KN, KP, KR, KZ, LA, LC, LK, LR, LS, LT, LU, LY, MA, MD, ME, MG, MK, MN, MW, MX, MY, MZ, NA, NG, NI, NO, NZ, OM, PE, PG, PH, PL, PT, RO, RS, RU, SC, SD, SE, SG, SK, SL, SM, ST, SV, SY, TH, TJ, TM, TN, TR, TT, TZ, UA, UG, US, UZ, VC, VN, ZA, ZM, ZW.

(25) Filing Language: English

(26) Publication Language: English

(30) Priority Data:
61/307,328 23 February 2010 (23.02.2010) US
61/307,324 23 February 2010 (23.02.2010) US

(71) Applicant (for all designated States except US): **CALIFORNIA INSTITUTE OF TECHNOLOGY** [US/US]; 1200 East California Boulevard, Pasadena, California 91125 (US).

(72) Inventors; and

(75) Inventors/Applicants (for US only): **PAVANI, Sri Rama Prasanna** [IN/US]; 1539 Vista Club Circle Apt. 102, Santa Clara, California 95054 (US). **YANG, Changhuei**

(84) Designated States (unless otherwise indicated, for every kind of regional protection available): ARIPO (BW, GH, GM, KE, LR, LS, MW, MZ, NA, SD, SL, SZ, TZ, UG, ZM, ZW), Eurasian (AM, AZ, BY, KG, KZ, MD, RU, TJ, TM), European (AL, AT, BE, BG, CH, CY, CZ, DE, DK,

[Continued on next page]

(54) Title: HIGH RESOLUTION IMAGING DEVICES WITH WIDE FIELD AND EXTENDED FOCUS

10

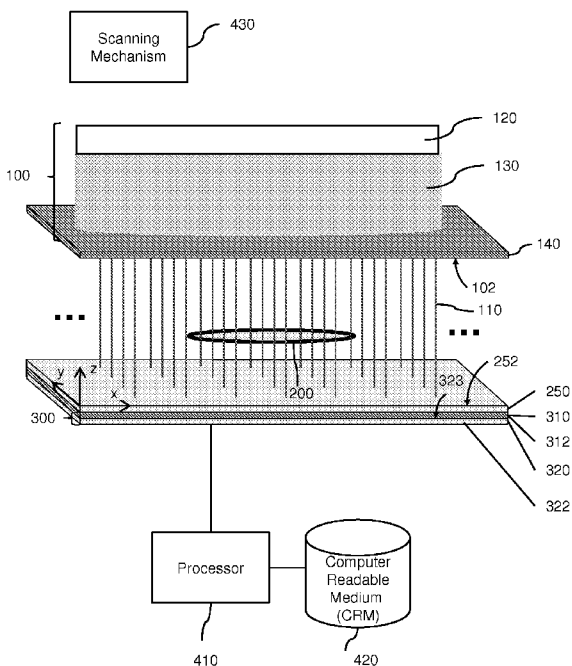

(57) Abstract: Embodiments of the present invention relate to a high-resolution imaging device with wide field and extended focus comprising a beam generator for generating a plurality of nondiffracting beams and a scanning mechanism for moving the plurality of nondiffracting beams relative to the object to illuminate a volume of the object. The high-resolution imaging device also comprises surface element and a body having a light detector layer outside the surface element. The light detector layer has a light detector configured to measure light data associated with the plurality of nondiffracting beams illuminating the volume of the object. In some cases, the high-resolution imaging device also includes a lens inside of the light detector layer. The lens is configured to focus the light on the light detector surface.



WO 2011/106327 A2

EE, ES, FI, FR, GB, GR, HR, HU, IE, IS, IT, LT, LU, LV, MC, MK, MT, NL, NO, PL, PT, RO, RS, SE, SI, SK, SM, TR), OAPI (BF, BJ, CF, CG, CI, CM, GA, GN, GQ, GW, ML, MR, NE, SN, TD, TG). **Published:** — *without international search report and to be republished upon receipt of that report (Rule 48.2(g))*

**HIGH RESOLUTION IMAGING DEVICES
WITH WIDE FIELD AND EXTENDED FOCUS**

CROSS-REFERENCES TO RELATED APPLICATIONS

[0001] This is a non-provisional application of, and claims priority to, U.S. Provisional Patent Application No. 61/307,324 entitled “Three Dimensional Imaging with Optofluidic Microscopes” filed on February 23, 2010 and U.S. Provisional Patent Application No. 61/307,328 entitled “High-Resolution Microscopy with a Wide Field and Extended Focus” filed on February 23, 2010. These provisional applications are hereby incorporated by reference in their entirety for all purposes.

[0002] This non-provisional application is related to the following co-pending and commonly-assigned patent applications, which are hereby incorporated by reference in their entirety for all purposes:

- U.S. Patent Application No. 13/032,449 entitled “Nondiffracting Beam Detection Devices for Three-Dimensional Imaging” filed on February 22, 2011.

BACKGROUND OF THE INVENTION

[0003] Embodiments of the present invention generally relate to imaging devices. More specifically, certain embodiments relate to high resolution imaging device with wide field and extended focus used in applications such as microscopy or photography.

[0004] With ever increasing forms and modalities, microscopes are proving to be powerful tools for exploring modern science. The gentleness of light has especially made an optical microscope a tool of choice to noninvasively probe living cells.

[0005] Despite being mature tools, conventional optical microscopes do not have the ability to acquire high resolution images of large sample volumes. This inability is the consequence of a tradeoff between a conventional microscope's resolution, its field of view, and its depth of field. While the resolution of a conventional microscope defines the size of the smallest sample detail that can be discerned, the field of view defines the largest transverse (x, y) sample area that can be imaged, and the depth of field defines the maximum axial (z) sample thickness that can be imaged in focus. Resolution, field of view, and depth of field are tightly constrained parameters in these conventional optical microscopes. In conventional microscopes, any attempt to increase resolution fundamentally results in a decrease in the depth of field, and for practical purposes decreases the field of view. Conventional microscopes are therefore restricted to acquire either low resolution images of large sample volumes, or high resolution images of small sample volumes.

BRIEF SUMMARY OF THE INVENTION

[0006] Embodiments of the present invention relate to a high resolution imaging device with wide field and extended focus (HRID) that can generate high resolution two-dimensional images of thick sample volumes. The HRID uses a plurality of nondiffracting beams (e.g., Bessel beams) that can propagate through the extended depth of a thick sample volume having an object being imaged. The HRID illuminates the sample volume by scanning the nondiffracting beams through the sample volume or moving the sample through the nondiffracting beams. The HRID images the object in the sample on a light detector (e.g., photosensor) directly (direct imaging) or with an inexpensive lens projecting images onto the light detector (projection imaging). In this way, the HRID can acquire two-dimensional images over large areas of the sample, while promptly showing intricate high resolution details, even those that are well outside the focal plane of traditional microscopes. The HRID

has an extended focal range due to the relatively long length of the nondiffracting beams compared to the depth of field in traditional microscopes.

[0007] One embodiment is directed to an HRID comprising a beam generator for generating a plurality of nondiffracting beams and a scanning mechanism for moving the plurality of nondiffracting beams relative to the object to illuminate a volume of the object. The HRID also comprises surface element and a body having a light detector layer outside the surface element. The light detector layer has a light detector configured to measure light data associated with the plurality of nondiffracting beams illuminating the volume of the object. In some cases, the HRID also includes a lens inside of the light detector layer.

[0008] Another embodiment is directed to an HRID comprising a beam generator configured to generate a plurality of nondiffracting beams and a body having a fluid channel, a surface layer, and a light detector layer. The fluid channel has a first channel surface and a second channel surface. The fluid channel also has a flow moving an object through the nondiffracting beams propagating through the fluid channel. The surface layer is located outside the first channel surface. The light detector layer is located outside the surface element. The light detector layer has a light detector configured to measure time varying light data associated with the plurality of nondiffracting beams as the object moves through the fluid channel.

[0009] These and other embodiments of the invention are described in further detail below.

BRIEF DESCRIPTION OF THE DRAWINGS

[0010] **FIG. 1** is a schematic drawing of components of a HRID in a direct imaging scheme, according to embodiments of the invention.

[0011] **FIG. 2(a)** is an intensity graph of a slice in an XZ plane of a Bessel beam (i.e., example of a nondiffracting beam), according to embodiments of the invention.

[0012] **FIG. 2(b)** is an intensity graph of a slice in the XZ plane of a focusing spherical wave with a 0.3 numerical aperture, according to embodiments of the invention.

[0013] **FIG. 3** is a schematic drawing of components of a HRID in a projection imaging scheme, according to embodiments of the invention.

[0014] **FIG. 4** is a schematic drawing of components of a HRID using optofluidic flow as a scanning mechanism and employs the direct imaging scheme to generate two-dimensional high resolution images of an object, according to embodiments of the invention.

[0015] **FIG. 5** is an illustration of an amplitude computer generated hologram (CGH) for generating nine nondiffracting beams, according to embodiments of the invention.

[0016] **FIG. 6** is an illustration of the nine nondiffracting beams generated by the amplitude CGH shown in **FIG. 5**, according to embodiments of the invention.

[0017] **FIG. 7** is a flow chart of an exemplary method of imaging with the HRID, according to embodiments of the invention.

[0018] **FIG. 8** is a block diagram of subsystems that may be present in the HRID, according to embodiments of the invention.

DETAILED DESCRIPTION OF THE INVENTION

[0019] Embodiments of the present invention will be described below with reference to the accompanying drawings. The HRID has a beam generator that can create a plurality of nondiffracting beams (e.g., series of Bessel beams) that propagate through the thickness of a sample (extended depth of field) having an object being imaged. A scanning mechanism is used to illuminate a sample volume with the object. The scanning mechanism either scans the nondiffracting beams (e.g., Bessel beams) through the sample volume or moves the sample volume through the nondiffracting beams. By using the scanning mechanism, the HRID can illuminate a thick sample over a large area (wide field of view). The HRID then images the object directly onto a light detector (direct imaging) or projects with a lens onto the light detector (projection imaging). In this way, the HRID can acquire two-dimensional images of large areas, while promptly showing intricate high resolution details, even those that are well outside the focal plane of traditional microscopes. The HRID has an extended focal range due to the relatively long length of the nondiffracting beams compared to the depth of field in traditional microscopes.

[0020] The HRID decouples the tradeoff that conventional imaging devices have between high resolution, and a wide field of view and depth of field. The HRID illuminates an object being imaged with nondiffracting beams (e.g., Bessel beams) that propagate through the depth of the object with a constant spot size in the submicron range. Since image resolution in an HRID is based primarily on spot size of the illuminating beams, an HRID is capable of providing images at submicron resolution since the spot size can be less than a micron. Since nondiffracting beams illuminate a line through a relatively long distance, the HRID can provide an extended depth of field through large sample volumes. The HRID provides a wide field of view using a plurality of illuminating nondiffracting beams and scanning to illuminate across a relatively large area. In this way, the HRID can acquire high resolution two-dimensional images of objects with a wide field of view and extended depth of field.

[0021] Embodiments of the invention provide one or more technical advantages. As mentioned above, one advantage of the HRID is that it can acquire high resolution images of objects with a wide field of view and an extended depth of field. Another advantage is that the HRID can be assembled with few components in a simple multi-layered arrangement (on-chip application). Since the body is multilayered, the HRID can be fabricated inexpensively

using standard semiconductor and micro/nanofabrication procedures. Also, a multilayered structure can be easily miniaturized. Another advantage is that the HRID can provide high throughput rates. For example, the HRID can use optofluidic flow as a scanning mechanism to quickly image objects flowing through the device. In addition, multiple HRIDs (e.g., 100, 200, etc.) can be combined in parallel since they are relatively compact, simple devices. Multiple HRIDs can provide high throughput imaging of large sample volumes. Another advantage is that the HRID has the ability to acquire high resolution images of large sample volumes. Unlike traditional microscopes, the HRID can illuminate an object with a series of nondiffracting beams that propagate through the sample with a constant spot size. The object is then imaged on a light detector (sensor) directly or with an inexpensive lens with a small numerical aperture. By scanning the sample through the series of beams, the HRID system has the ability to acquire high resolution images of large sample volumes. With this high resolution imaging, the HRID may prove particularly useful to biologists and others, for example, to investigate large sample volumes, while simultaneously being able to discern intricate high resolution details.

[0022] I. HRID

[0023] The HRID can be implemented in a direct imaging scheme and in a projection imaging scheme. In the directly imaging scheme, an object is illuminated by the nondiffracting beams (e.g., Bessel beams) and the transmission of the nondiffracting beams are detected directly by an imaging light detector (sensor). In the projection imaging scheme, the object is imaged by a simple lens projecting onto an imaging light detector (sensor). In either scheme, to acquire an image of the object, the HRID uses a scanning device (e.g., raster scanner) to scan the object, or uses a similar scanning mechanism as used in optofluidic microscopy, where an image can be acquired by simply doing linear scanning. An example of a scanning mechanism used in optofluidic microscopy can be found in X. Heng, D. Erickson, L. R. Baugh, Z. Yaqoob, P. W. Sternberg, D. Psaltis, and C. H. Yang, "Optofluidic microscopy - a method for implementing a high resolution optical microscope on a chip," Lab on a Chip 6, 1274-1276 (2006), which is hereby incorporated by reference in its entirety for all purposes.

[0024] A. Direct Imaging

[0025] **FIG. 1** is a schematic drawing of components of a HRID **10** in a direct imaging scheme, according to embodiments of the invention. The HRID **10** includes a beam

generator **100** having an illumination source **120** providing an excitation beam **130** (e.g., plane wave excitation beam) and a holographic element **140** (e.g., CGH) generating the plurality of nondiffracting beams **110** when illuminated by the excitation beam **130**. The beam generator **100** also includes a beam generator surface **102**. The HRID **10** also includes a surface element **250** having a first surface **252**. The HRID **10** also includes a body **300** comprising a filter layer **310** having a filter **312** and a light detector layer **320** having a light detector **322**. In some embodiments, the HRID **10** may include more or fewer layers, and may include only a light detector layer **320** having a light detector **322**. An object **200** being imaged is located between the surface element **250** and the beam generator **100** of the HRID **10**. In other embodiments, the object **200** may have another suitable location between the surface element **250** and the beam generator **100** of the HRID **10**. For example, the object **200** may be located proximal the first surface **252** of the surface element **250** in some embodiments. The HRID **10** also includes a processor **410** communicatively coupled to the light detector **322**, and a computer readable medium **420** communicatively coupled to the processor **410**, and a scanning mechanism **430** capable of moving the nondiffracting beams **110** relative to the object **200** or the object **200** relative to the nondiffracting beams **110**.

[0026] The HRID **10** also includes an x-axis, a y-axis, and a z-axis. The x-axis and y-axis lie in the plane of the first surface **252** of the surface element **250**. The z-axis is orthogonal to this plane.

[0027] In a general operation, the HRID **10** shown in FIG. 1 illuminates the object **200** with the plurality of nondiffracting beams **110** that propagate through the object **200** with a constant spot size or substantially constant spot size. The object **200** is then imaged on the light detector **322** directly (direct imaging). By using the scanning mechanism **430** to scan the object **200** through the plurality of nondiffracting beams **110** or the nondiffracting beams **110** through the object **200**, the HRID **10** has the ability to acquire high resolution images of large sample volumes.

[0028] As used herein, a nondiffracting beam **110** refers to a field of electromagnetic radiation that has little to no diffraction with propagation. For example, as a nondiffracting beam **110** propagates, the nondiffracting beam does not substantially diffract and maintains a tight focus confining photons within a narrow width and sustaining constant width over a relatively long section of the beam's axis. An example of a nondiffracting beam is a Bessel beam.

[0029] In **FIG. 1**, each nondiffracting beam **110** can have any suitable light property (e.g., intensity, phase, polarization etc.) and any suitable size (spot size, length, etc.). For example, the nondiffracting beam **110** can have a substantially constant spot size of less than a micron in diameter (submicron size). As another example, the nondiffracting beam **110** may have a length of 250 microns or greater.

[0030] **FIGS. 2(a)** and **2(b)** illustrate a side by side comparison of a Bessel beam (i.e. a type of nondiffracting beam) and a focusing spherical wave with 0.3 numerical aperture. **FIG. 2(a)** is an intensity graph of a slice in an XZ plane of the Bessel beam from simulation results, according to embodiments of the invention. **FIG. 2(b)** is an intensity graph of a slice in the XZ plane of the focusing spherical wave with a 0.3 numerical aperture from simulation results, according to embodiments of the invention. The Bessel beam in **FIG. 2(a)** has a beam length of at least 250 microns and has resolution (half spotsizes) of less than 1 μm . The beam of the focusing spherical wave in **FIG. 2(b)** has a beam length of approximately 10 microns and has a resolution of about 1 μm . As shown, the illustrated Bessel beam has a narrow width for an extended length (z-distance) whereas the focusing spherical wave has a relatively short beam length in comparison. By comparing beam lengths, **FIGS. 2(a)** and **2(b)** illustrate that a Bessel beam or other nondiffracting beam can confine photons within a narrow width through an extended depth of field in comparison to the shorter depth of field of the focusing spherical wave.

[0031] In many embodiments, the plurality of nondiffracting beams **110** can include any suitable number of nondiffracting beams **110** (e.g., 1, 50, 100, 200, 1000, etc.) in any suitable arrangement. Some examples of suitable arrangements include a one-dimensional array, a two-dimensional array, a three-dimensional array, and a multiplicity of one-dimensional, two-dimensional, and/or three-dimensional arrays of any suitable dimensions. An example of a one-dimensional (29 x 1) array is shown in **FIG. 4**. Examples of two-dimensional (7x4) arrays are shown in **FIGS. 1** and **3**. Although the illustrated examples show certain dimensions, arrays having other suitable dimensions (e.g., 200 x 1, 200 x 100, 1000 x 200, 20 x 10, etc.) can be used in other embodiments.

[0032] In addition, the arrays of embodiments can have any suitable orientation or combination of orientations. In some embodiments, the arrays may be oriented along the x axis. Examples of two-dimensional arrays oriented along the x-axis are shown **FIGS. 1** and **3**. In other embodiments, the arrays may be oriented at an angle with respect to the x-axis.

An example of a plurality of nondiffracting beams **110** arranged in a one-dimensional array that extends diagonally at an angle with respect to the x axis is shown in **FIG. 4**. In this illustrated example, the one-dimensional array extends diagonally from one lateral side to an opposing lateral side of the fluid channel **330** having a fluid flow. In this example, the array is oriented at an angle, α , with respect to a longitudinal axis of the fluid channel **330**.

[0033] Each of the nondiffracting beams **110** has an illumination path which lies substantially along a line. In **FIG. 1**, the plurality of nondiffracting beams **110** lie in the z-direction and have illumination paths that lie substantially along z-directional lines at a set of discrete transverse (X, Y) locations across a portion of the surface element **250**. In other embodiments, the nondiffracting beams **110** may lie at an angle to the z-axis.

[0034] As used herein, a beam generator **100** refers to any suitable device or combination of devices that can generate the plurality of nondiffracting beams **110**. An example of a suitable combination of devices is shown in **FIG. 1** and includes a holographic element **140** (e.g., CGH) in communication with an illumination source (e.g., laser) **130** providing an excitation beam **130** (e.g., plane wave excitation beam). In this example, the holographic element **140** generates the plurality of nondiffracting beams **110** upon being illuminated by the excitation beam **130**. Another example of a suitable combination of devices includes one or more microaxicons. Another example of suitable combination of devices includes a device having optical fibers. These examples and others are described in Section III below. Although **FIG. 1** includes a holographic element **140** and illumination source **120** providing an excitation beam **130**, other embodiments may include another suitable device or combination of devices that can generate the plurality of nondiffracting beams **110**.

[0035] The illumination source **120** may be any suitable device(s) capable of providing an excitation beam **130**. Some examples of suitable devices include light-emitting diodes (LEDs), laser of suitable wavelength, broadband source (e.g., mercury lamp, halogen lamp, etc.) with a suitable filter, natural light, etc. Suitable illumination sources are commercially available. The illumination source **120** may be placed in any location and at any orientation that allows it to generate an appropriate excitation beam **130** at the holographic element **140**. The illumination source **120** may provide an appropriate excitation beam **130** of a suitable wavelength, intensity, phase, polarization, spin angular momentum or other light property, and spatial distribution. The illumination source **120** may provide a

coherent, incoherent, or partially coherent excitation beam **130**. In exemplary fluorescence/phosphorescence embodiments, the illumination source **120** provides excitation light having a first light property (e.g., first wavelength) matching the excitation wavelength of the fluorophores in an object **200** being imaged by the HRID **10**. The fluorophores are excited by the excitation light and emit light (emissions) of a second light property (e.g., second wavelength). Some examples of suitable excitation light include fluorescence, 2-photon or higher order fluorescence, Raman, second harmonic or higher order, or other emission mechanism that results in emissions at a different wavelength or other different light property than the excitation light. Although the illumination source **120** in **FIG. 1** is a component of the HRID **10**, the illumination source **120** may be separate from the HRID **10** in other embodiments.

[0036] As used herein, a holographic element **140** refers to any CGH or optically recorded hologram capable of converting an excitation beam **130** from an illumination source **120** into the plurality of nondiffracting beams **110**. In **FIG. 1**, the holographic element **140** is a CGH. In many illustrated embodiments, the holographic element **140** transforms a planar wave of the excitation beam **130** from the illumination source **120** into the plurality of nondiffracting beams **110**. The holographic element **140** can be made of any suitable material or materials. Some examples of suitable holographic materials include photographic emulsions, dichromated gelatin, and photoresists. The holographic element **140** can have any suitable dimensions (e.g., 1 mm x 1 mm, 2 mm x 2 mm, 5 mm x 2 mm, 10 mm x 10 mm, 10 mm x 50 mm, etc.). In the case of a optically recorded hologram, the holographic element **140** can be made using any holographic recording technique capable of encoding (recording) data about the plurality of nondiffracting beams **110**. Some examples of suitable holographic recording techniques include in-line (Gabor) and off-axis (Leith-Upatnieks). To play back the recording, the holographic element **140** can be illuminated by an excitation beam **130** having the same wavelength, same spatial distribution, but not necessarily the same intensity, as the reference beam used to record the holographic element **140**. In many embodiments, the holographic element **140** is a CGH that is designed to generate a plurality of well-separated nondiffracting beams **110** upon being illuminated by a plane wave excitation beam **130**. Some examples of suitable CGHs are described in Section III below.

[0037] The scanning mechanism **430** can include any suitable device (e.g., raster scanner) or structural element (e.g., fluid channel) capable of moving the object **200** or surface element **250** holding the object **200** relative to the plurality of nondiffracting beams

110 or moving the plurality of nondiffracting beams **110** relative to the object **200**. Although the scanning mechanism **430** is a component of the HRID **10** in illustrated embodiments, the scanning mechanism **430** may be separate from the HRID **10** in other embodiments.

Although not shown, the scanning mechanism **430** can be associated with the beam generator **100**, the object **200**, or the surface element **250** (e.g., a slide holding an object **200**).

[0038] In some embodiments, the scanning mechanism **430** can be associated with one or more components of the beam generator **100**. For example, the scanning mechanism **430** can be associated with the holographic element **140** of the beam generator **100** to be able to move the plurality of nondiffracting beam **110** through a volume of the object **200**.

[0039] In some embodiments, the scanning mechanism **430** can be associated with the object **200** such that it is able to move the object **200** being imaged relative to the plurality of nondiffracting beams **110**. For example, the scanning mechanism **320** can be an optical tweezer that can move the object **200** relative to the plurality of nondiffracting beams **110**. As another example, the scanning mechanism **430** can be similar to the scanning mechanism as used in optofluidic microscopy, where an image is acquired as an object **200** moves in a fluid flow through a fluid channel **330** as shown in FIG. 4. An example of a scanning mechanism used in optofluidic microscopy can be found in X. Heng, D. Erickson, L. R. Baugh, Z. Yaqoob, P. W. Sternberg, D. Psaltis, and C. H. Yang, "Optofluidic microscopy - a method for implementing a high resolution optical microscope on a chip," Lab on a Chip 6, 1274-1276 (2006), which is hereby incorporated by reference in its entirety for all purposes.

[0040] In some embodiments, the scanning mechanism **430** can be associated with the surface element **250** (e.g., slide or other translational platform). For example, the scanning mechanism **430** can be coupled to the surface element **250** and the surface element **250** can hold the object **200** such that it is able to move the object **200** being imaged relative to the plurality of nondiffracting beams **110**.

[0041] Any suitable object **200**, objects **200**, or portion of an object **200** may be imaged by the HRID **10**. Typically, the HRID **10** images an object **200** within a specimen (sample) introduced to the HRID **10**. For example, a specimen with objects **200** may be located on the surface element **250** (e.g., a slide) and the surface element **250** is placed on the body **300** of the HRID **10** for imaging of the objects **200**. Suitable objects **200** can be biological or inorganic entities. Examples of biological entities include whole cells, cell components, microorganisms such as bacteria or viruses, cell components such as proteins,

etc. Inorganic entities may also be imaged by embodiments of the invention. Examples of inorganic entities include mineral fibers, and crystals. The object **200** can have any thickness.

[0042] In many embodiments, the plurality of nondiffracting beams **110** can illuminate through the entire depth of the sample having one or more objects **200**. By implementing the scanning mechanism **430**, a sample (specimen) volume can be illuminated by the plurality of nondiffracting beams **110**. The sample volume may include a portion of an object volume, or one or more object volumes. In many embodiments, the entire sample volume including the volume of one or more objects **200** may be illuminated by the plurality of nondiffracting beams **110**.

[0043] The HRID **10** includes a body **300**. In some embodiments, the body **300** may be a single, monolithic structure. In other embodiments, the body **300** may be a multi-layer structure. The layers of a multi-layer body **300** may be of any suitable material or combination of materials having any suitable thickness or thicknesses. The layers of a multi-layer body **300** may also include any suitable device(s) (e.g., light detector **322**).

[0044] In **FIG. 1**, the HRID **10** includes a multi-layer body **300** having a filter layer **310** and a light detector layer **320** having a light detector **322**. Although the body **300** in **FIG. 1** has certain layers, other embodiments may integrate, omit, or add one or more layers or change the location of one or more layers in the body **300**. For example, the body **300** may omit the filter layer **310**. As another example, the body **300** may include a transparent protective layer (not shown) outside the filter layer **310** to isolate the filter layer **310** and/or the light detector **322**. As another example, the body **300** may include the surface element **250** as a surface layer of the body **300**. In yet another example, the body **300** may include a lens **302** (shown in **FIG. 3**) between the surface element **250** and the filter layer **310**.

[0045] The body **300** may be fabricated using standard semiconductor and micro/nanofabrication procedures. During an exemplary fabrication of an embodiment of the body **300**, a filter layer **216** can be placed on top of a light detector layer **320**. After fabrication, the surface element **250** can be located on top of the filter layer **310** during an imaging operation.

[0046] In **FIG. 1**, the filter layer **310** includes a filter **312**. A filter **312** refers to any suitable device(s) (e.g., optical filters) capable of selectively transmitting light having select light properties (e.g., polarization, wavelength, frequency, intensity, phase, spin angular

momentum, etc.) while substantially removing light the remaining light by any suitable method such as reflection, absorption or interference. Some examples of suitable filters include interference filters, absorption filters, etc. Any type of filter can be used such as dichroic filters, monochromatic filters, etc. In one embodiment, a polarization filter may be used.

[0047] In a photoluminescence (e.g., fluorescence or phosphorescence) imaging embodiment, the filter layer **310** can be used to transmit emissions from fluorophores in the object **200** and substantially remove excitation light. In this embodiment, the plurality of nondiffracting beams **110** provides an excitation light having an excitation wavelength that can activate fluorophores in the object **200**. The activated fluorophores can emit an emission light (emissions). The emission light can be electromagnetic radiation with specific properties such that it passes through the filter **312** to the light detector **322**. The resulting light data can thus be substantially associated with the emissions from the activated fluorophores in the object **200**.

[0048] In **FIG. 1**, the light detector layer **320** includes a light detector **322**. As used herein, a light detector **322** (e.g., a photosensor) refers to any suitable device capable of generating one or more signals with light data based on light received by the light detector **322**. Each signal with light data may be in the form of electrical current that from the photoelectric effect. The light detector **322** can detect light having any light property (e.g., wavelength(s), phase(s), intensity(ies), frequency(ies), polarization(s), spin angular momentum(s), and/or other light properties).

[0049] The light detector **322** includes a light detector surface **323**. Although not shown, the light detector **322** also includes a suitable number (e.g., 1, 100, 1000, etc.) of discrete light detecting elements (e.g., pixels). The light detecting elements can be arranged in a suitable form such as a single light detecting element, a one-dimensional array of light detecting elements, a two-dimensional array of light detecting elements, or a multiplicity of one-dimensional and/or two-dimensional arrays of light detecting elements. The arrays can be in any suitable orientation or combination of orientations. In some cases, the array(s) of light detecting elements may have the same orientation as the orientation of the plurality of nondiffracting elements **110** and are aligned to correspond to the plurality of nondiffracting beams **110**. For example, the light detector **322** in **FIG. 3** may include an array or arrays of

light detecting elements oriented at an angle, α with respect to the x-axis to correspond to the array of nondiffracting beams having the same orientation.

[0050] Some examples of light detectors **322** having a single light detecting element include a photo-diode (PD), an avalanche photo-diode (APD) and a photomultiplier tubes (PMT). Some examples of light detectors **322** having one-dimensional or two-dimensional arrays include a charge coupled device (CCD) array, a complementary metal-oxide-semiconductor (CMOS) array, an APD array, a PD array, a PMT array, etc. Suitable light detectors **322** are commercially available.

[0051] Each light detecting element of the light detector **322** may be of any suitable size (e.g., 1-10 microns) and any suitable shape (e.g., circular, square, etc.). For example, a complementary metal-oxide-semiconductor (CMOS) or charge coupled device (CCD) light detecting element may be 1-10 microns and an APD or PMT light detecting element may be as large as 1-4 mm.

[0052] One or more light detecting elements in the light detector **322** may uniquely correspond to each of the nondiffracting beams **110** in some embodiments. For example, each light detecting element may correspond to a unique nondiffracting beam **110**. In this example, the light detecting element may receive light associated with the corresponding nondiffracting beam **110** and generate a signal with light data associated with the light received. In another example, the light detector **322** may be a two dimensional array of light detecting elements (e.g., 100 x 100 array of light detecting elements) that comprises one or more sets of smaller two-dimensional arrays of light detecting elements (e.g., 100 sets of 10 x 10 arrays of light detecting elements). Each set (e.g., 10 x 10 array) can correspond to a unique nondiffracting beam **110**. In this example, the each set may receive light associated with the corresponding nondiffracting beam **110** and generate a signal with light data associated with the light received.

[0053] The light detector **322** generates one or more signals with light data associated with the light received by the light detecting elements in the light detector **322**. As used herein, light data refers to any suitable information related to the light received by the light detecting elements in the light detector **322**. Light data may include, for example, information about the properties of the light detected such as the intensity of the light, the wavelength(s) of the light, the frequency or frequencies of the light, the polarization(s) of the light, the phase(s) of the light, the spin angular momentum(s) of the light, and/or other light

properties associated with the light received. Light data may also include the location of the light detecting element receiving the light. Light data may be data based on a single time, based on multiple times, or based on a time varying basis. Time varying light data refers to light data that is based on a time varying basis. In some embodiments such as the optofluidic application shown in **FIG. 4**, the time varying light data may be in the form of line scans.

[0054] At any given time, the light data from the light detector **322** corresponds to a set of discrete transverse (X, Y) points (e.g., scatterers) on the object **200**, with an extended depth (Z) range along the illumination paths of the nondiffracting beams **110**. By using the scanning mechanism **430** to move the nondiffracting beams **110** relative to the object **200** or the object **200** relative to the nondiffracting beams **110**, while continuously acquiring light data from the light detector **322**, the HRID **10** can acquire light data from many to all transverse (X, Y) points of the sample with an extended depth (Z) range. In this way, the HRID **10** can acquire light data from a sample volume with the object **200**. The HRID can use the light data to acquire high-resolution two-dimensional images of an object **200** in the sample with a wide field of view and an extended depth of focus.

[0055] The surface element **250** may be a component of the HRID **10** or may be separate from the HRID **10**. In addition, the surface element **250** may be a layer of the body **300** or may be a separate component from the body **300**. In the illustrated embodiments shown in **FIGS. 1** and **3**, the surface element **250** is a separate component from the body **300** that may be removably located proximal the filter layer **310** or coupled to the filter layer **310**. For example, the surface element **250** may be a slide or other platform made of transparent material that can be detachably located on the body **300**. In some cases, the object **200** being imaged can be held (e.g., mounted) to the surface element **250** by an attachment method (e.g., slide cover). In some cases, the surface element **250** may be a translation platform that can be moved by the scanning mechanism **430**. In other embodiments, the surface element **250** may be a layer of the body **300**. For example, the surface element **250** may be a surface layer of the body **300**. In the illustrated embodiment shown in **FIG. 4**, for example, the surface element **250** is a surface layer of a fluid channel **330** in a multi-layer body **300**.

[0056] The processor **410** may include any suitable processor(s) (e.g., microprocessor) that can receive signals with light data from the light detector **322** associated with the light received by the light detector **322**. The processor **410** can generate a high resolution two-dimensional image of the object **200** or a portion of the object **200** based on

the light data received from the light detector **322**. The processor **410** executes code stored on the CRM **420** to perform some of the functions of HRID **10** such as interpreting the light data from the light detector **322**, performing analyses of the light data, and generating one or more images of the object **200** based on the light data.

[0057] The CRM (e.g., memory) **420** stores code for performing some functions of the HRID **10**. The code is executable by the processor **410**. In some embodiments, the CRM **420** may comprise: a) code for interpreting light data received from the light detector **322**, b) code for generating one or more images of the object **200** based on non-time varying light data, c) code for determining the propagation angle of one or more nondiffracting beams **110**, d) code for compiling line scans or other time varying light data into a two-dimensional image of the object based on the time varying light data, e) code for displaying the generated images, f) and/or any other suitable code for performing functions of the HRID **10**. The CRM **420** may also include code for performing any of the signal processing or other software-related functions that may be created by those of ordinary skill in the art. The code may be in any suitable programming language including C, C++, Pascal, etc.

[0058] The HRID **10** can be used to generate any suitable type of image such as a fluorescence image, phosphorescence image, intensity images, phase image, differential interference contrast (DIC) image, etc. The images can be black and white images, grey tone images, color images, etc.

[0059] In one embodiment, the HRID **10** can generate a photoluminescence (e.g., fluorescence or phosphorescence) image of the object **200**. In this embodiment, the filter layer **310** includes any suitable device(s) (e.g., optical filter) that can reject excitation light and pass emission light from the fluorophores. The illumination source **120** (e.g., laser) provides an excitation light having an excitation wavelength that can excite fluorophores in the object **200**. The excited fluorophores emit an emission light. The light data measured by the light detector **322** is associated with the emission light from the fluorophores in the object **200**. The processor **410** generates image data associated with the emission light data and generates a photoluminescence image of the object **200** based on the image data.

[0060] Modifications, additions, or omissions may be made to HRID **10** without departing from the scope of the disclosure. For example, the HRID **10** may omit the filter layer **132** in embodiments of the HRID **10** which do not perform photoluminescence imaging. As another example, other embodiments of the HRID **10** may include a display

communicatively coupled to the processor **410** to receive output data such as image data and provide output such as an image or image data to a user of the HRID **10**. In addition, the components of HRID **10** may be integrated or separated according to particular needs. For example, the processor **410** or other suitable processor may be integrated into the light detector **322** so that the light detector **322** can perform one or more of the functions of the processor **410** in some embodiments. As another example, the processor **410** and/or CRM **420** may be components of a computer, which is separate from the HRID **10** or a component of the HRID **10**. As another example, the processor **410** and/or CRM **20** may be separate from the HDID **10**.

[0061] B. Projection Imaging

[0062] In projection imaging embodiments, the HRID **10** further includes a lens between the filter layer and the surface element **250** to project the image of the illuminated regions of the object **200** onto the light detector **322**. In these embodiments, the lens may be added to provide a physical barrier or protective layer between the light detector **322** and the surface element **250** or liquid sample having the object **200**. The focusing of the lens **302** can compensate for diffraction that may occur due to the increased separation of the light detector **322**. Without the focusing of the lens **302**, the light may diffract in the increased separation and the light detector **322** may provide less accurate light data, especially if the light is based on weak photoluminescence emissions in a photoluminescence imaging embodiment.

[0063] **FIG. 3** is a schematic drawing of components of a HRID **10** in a projection imaging scheme, according to embodiments of the invention. The HRID **10** includes a beam generator **100** having an illumination source **120** providing an excitation beam **130** and a holographic element **140** generating the plurality of nondiffracting beams **110** when illuminated by the excitation beam **130**. The beam generator **100** also includes a beam generator surface **102**. The HRID **10** also includes a surface element **250** having a first surface **252**. The HRID **10** also includes a body **300** having a lens layer **301** with a lens **302**, a filter layer **310** having a filter **312**, and a light detector layer **320** having a light detector **322**. An object **200** being imaged is located between the surface element **250** and the beam generator **100** of the HRID **10**. In other embodiments, the object **200** may have another suitable location between the surface element **250** and the beam generator **100** of the HRID **10**. For example, the object **200** may be located proximal the first surface **252** of the surface element **250** in some embodiments. The HRID **10** also includes a processor **410**

communicatively coupled to the light detector **322**, and a computer readable medium **420** communicatively coupled to the processor **410**, and a scanning mechanism **430** capable of moving the nondiffracting beams **110** relative to the object **200** or the object **200** relative to the nondiffracting beams **110**.

[0064] The HRID **10** also includes an x-axis, a y-axis, and a z-axis. The x-axis and y-axis lie in the plane of the first surface **252** of the surface element **250**. The z-axis is orthogonal to this plane.

[0065] In a general operation, the HRID **10** in **FIG. 3** illuminates the object **200** with the plurality of nondiffracting beams **110** that propagate through the object **200** with a constant spot size or substantially constant spot size. The object **200** is then imaged on the light detector **322** with a lens **302** having a small numerical aperture. The lens **302** projects the image of the illuminated regions of the object **200** onto the light detector **322** (projection imaging). By using the scanning mechanism **430** to scan the object **200** through the plurality of nondiffracting beams **110** or the nondiffracting beams **110** through the object **200**, the HRID **10** has the ability to acquire high resolution images of large sample volumes.

[0066] The lens **302** can be any lens with suitable properties. Suitable lenses are commercially available. In many projection imaging embodiments, the lens **302** has a numerical aperture (NA) smaller than that of the nondiffracting beams **110** such that the depth of field of the lens **302** may match or exceed the maximum nondiffracting depth of field (range) of the nondiffracting beams **110**. That is, because the NA of the lens **302** is smaller than that of the nondiffracting beam **110**, its depth of field can be high enough to image the entire length of the nondiffracting beam **110** in focus. In one such embodiment, the lens **302** is located so that its object plane (focal plane) is half way through the depth of field of the nondiffracting beams **110**. When a lens **302** with a NA smaller than the nondiffracting beams **110** is in this location, the entire thickness of the object **200** illuminated by the beam generator **100** can be imaged sharply in focus on the light detector **110**. Although a single lens **302** is described in certain projecting imaging embodiments, any suitable number of lenses can be used in other embodiments.

[0067] As mentioned above, the image resolution provided by the HRID **10** is based on the spot size of the nondiffracting beams **110**. The image resolution is not based on the resolution of the lens **302**. For this reason, the HRID **10** can use a lens **302** with a low numerical aperture and a resolution as large as the distance between adjacent nondiffracting

beams **110** in the plurality of nondiffracting beams **110** without substantially affecting the high resolution capability of the HRID **10**. Using a lens **302** with a low numerical aperture can also provide the advantage of allowing the HRID **10** to acquire aberration-free images of a much larger region of the sample/specimen than would be possible with a traditional microscope having a similar resolution.

[0068] In **FIG. 3**, the beam generator **100** generates a plurality of nondiffracting beams **110** (e.g., Bessel beams). Each nondiffracting beam **110** has little to no diffraction with propagation. For example, as each nondiffracting beam **110** propagates, the nondiffracting beam **110** does not substantially diffract and maintains a tight focus confining photons within a narrow width and sustaining constant width over a relatively long section of the beam's axis.

[0069] The nondiffracting beam **110** can have any suitable light property (intensity, phase, etc.) and any suitable size (spot size, length, etc.). For example, the nondiffracting beam **110** may have a substantially constant spot size of less than a micron in diameter (e.g., submicron size). As another example, the nondiffracting beam **110** may have a length of 250 microns or greater. An illustrated example of a Bessel beam having a length of approximately 200 microns is shown in **FIG. 2(a)**.

[0070] Generally, the plurality of nondiffracting beams **110** of embodiments can include any suitable number of nondiffracting beams **110** (e.g., 1, 50, 100, 200, 1000, etc.) in any suitable arrangement (e.g., a two-dimensional array, a three-dimensional array, and a multiplicity of one-dimensional, two-dimensional, and/or three-dimensional arrays of any suitable dimensions) having any suitable orientation or combination of orientations. In the illustrated example shown in **FIG. 3**, the plurality of nondiffracting beams **110** is arranged in a two-dimensional array having 7 x 4 dimensions and that is oriented along (aligned with) the x-axis. In other embodiments, the plurality of nondiffracting beams **110** may be in another arrangement or may have other dimensions (e.g., 200 x 1, 200 x 100, 1000 x 200, 20 x 10, etc.) and/or different orientation(s).

[0071] Each of the nondiffracting beams **110** has an illumination path which lies substantially along a line. In **FIG. 3**, the plurality of nondiffracting beams **110** lie in the z-direction and have illumination paths that lie substantially along z-directional lines at a set of discrete transverse (X, Y) locations across a portion of the surface element **250**. In other embodiments, the nondiffracting beams **110** may lie at an angle to the z-axis.

[0072] In FIG. 3, the beam generator 100 includes a holographic element (e.g., holographic plate) 140 in communication with an illumination source (e.g., laser) 130 providing an excitation beam 130 (e.g., plane wave excitation beam). The holographic element 140 generates the plurality of nondiffracting beams 110 upon being illuminated by the excitation beam 130. In other embodiments, another suitable device or combination of devices can be used to generate the plurality of nondiffracting beams 110. Some examples of suitable devices are described in Section III below.

[0073] The illumination source 120 may be any suitable device(s) capable of providing an excitation beam 130. Some examples of suitable devices include light-emitting diodes (LEDs), laser of suitable wavelength, broadband source (e.g., mercury lamp, halogen lamp, etc.) with a suitable filter, natural light, etc. Suitable illumination sources are commercially available. The illumination source 120 may be placed in any location and at any orientation that allows it to generate an appropriate excitation beam 130 at the holographic element 140. The illumination source 120 may provide an appropriate excitation beam 130 of a suitable wavelength, intensity, phase, polarization, spin angular momentum or other light property, and spatial distribution. The illumination source 120 may provide a coherent, incoherent, or partially coherent excitation beam 130. In exemplary fluorescence/phosphorescence embodiments, the illumination source 120 provides excitation light having a first light property (e.g., first wavelength) matching the excitation wavelength of the fluorophores in an object 200 being imaged by the HRID 10. The fluorophores are excited by the excitation light and emit light (emissions) of a second light property (e.g., second wavelength). Some examples of suitable excitation light include fluorescence, 2-photon or higher order fluorescence, Raman, second harmonic or higher order, or other emission mechanism that results in emissions at a different wavelength or other different light property than the excitation light. Although the illumination source 120 in FIG. 1 is a component of the HRID 10, the illumination source 120 may be separate from the HRID 10 in other embodiments.

[0074] In FIG. 3, the holographic element 140 is a CGH capable of capable of converting an excitation beam 130 (e.g., planar wave excitation beam) from an illumination source 120 into the plurality of nondiffracting beams 110. The holographic element 140 can be made of any suitable material or materials. Some examples of suitable holographic materials include photographic emulsions, dichromated gelatin, and photoresists. The holographic element 140 can have any suitable dimensions (e.g., 1 mm x 1 mm, 2 mm x 2

mm, 5 mm x 2 mm, 10 mm x 10 mm, 10 mm x 50 mm, etc.). In the case of a optically recorded hologram, the holographic element **140** can be made using any holographic recording technique capable of encoding (recording) data about the plurality of nondiffracting beams **110**. Some examples of suitable holographic recording techniques include in-line (Gabor) and off-axis (Leith-Upatnieks). To play back the recording, the holographic element **140** can be illuminated by an excitation beam **130** having the same wavelength, same spatial distribution, but not necessarily the same intensity, as the reference beam used to record the holographic element **140**. In many embodiments, the holographic element **140** is a CGH that is designed to generate a plurality of well-separated nondiffracting beams **110** upon being illuminated by a plane wave excitation beam **130**. Some examples of suitable CGHs are described in Section III below.

[0075] The scanning mechanism **430** can include any suitable device (e.g., raster scanner) or structural element (e.g., fluid channel) capable of moving the object **200** or surface element **250** holding the object **200** relative to the plurality of nondiffracting beams **110** or moving the plurality of nondiffracting beams **110** relative to the object **200**. Although the scanning mechanism **430** is a component of the HRID **10** in illustrated embodiments, the scanning mechanism **430** may be separate from the HRID **10** in other embodiments. Although not shown, the scanning mechanism **430** can be associated with the beam generator **100**, the object **200**, or the surface element **250** (e.g., a slide holding an object **200**).

[0076] In some embodiments, the scanning mechanism **430** can be associated with one or more components of the beam generator **100**. For example, the scanning mechanism **430** can be associated with the holographic element **140** of the beam generator **100** to be able to move the plurality of nondiffracting beam **110** through a volume of the object **200**.

[0077] In some embodiments, the scanning mechanism **430** can be associated with the object **200** such that it is able to move the object **200** being imaged relative to the plurality of nondiffracting beams **110**. For example, the scanning mechanism **320** can be an optical tweezer that can move the object **200** relative to the plurality of nondiffracting beams **110**. As another example, the scanning mechanism **430** can be similar to the scanning mechanism as used in optofluidic microscopy, where an image is acquired as an object **200** moves in a fluid flow through a fluid channel **330** as shown in FIG. 4. An example of a scanning mechanism used in optofluidic microscopy can be found in X. Heng, D. Erickson, L. R. Baugh, Z. Yaqoob, P. W. Sternberg, D. Psaltis, and C. H. Yang, "Optofluidic microscopy - a

method for implementing a high resolution optical microscope on a chip," Lab on a Chip 6, 1274-1276 (2006), which is hereby incorporated by reference in its entirety for all purposes.

[0078] In some embodiments, the scanning mechanism **430** can be associated with the surface element **250** (e.g., slide or other translational platform). For example, the scanning mechanism **430** can be coupled to the surface element **250** and the surface element **250** can hold the object **200** such that it is able to move the object **200** being imaged relative to the plurality of nondiffracting beams **110**.

[0079] Any suitable object **200**, objects **200**, or portion of an object **200** may be imaged by the HRID **10**. In many embodiments, the HRID **10** images an object **200** within a specimen (sample) introduced to the HRID **10**. For example, a specimen with objects **200** may be located on the surface element **250** (e.g., a slide) and the surface element **250** placed on the body **300** of the HRID **10** for imaging of the objects **200**. Suitable objects **200** can be biological or inorganic entities. Examples of biological entities include whole cells, cell components, microorganisms such as bacteria or viruses, cell components such as proteins, etc. Inorganic entities may also be imaged by embodiments of the invention. Examples of inorganic entities include mineral fibers, and crystals. The object **200** can have any thickness.

[0080] In many embodiments, the plurality of nondiffracting beams **110** can illuminate through the entire depth of the sample having one or more objects **200**. By implementing the scanning mechanism **430**, a sample (specimen) volume can be illuminated by the plurality of nondiffracting beams **110**. The sample volume may include a portion of an object volume, or one or more object volumes. In many embodiments, the entire sample volume including the volume of one or more objects **200** may be illuminated by the plurality of nondiffracting beams **110**.

[0081] In FIG. 3, The HRID **10** includes a multi-layer body **300** comprising a lens layer **301** with a lens **302**, a filter layer **310** having a filter **312**, and a light detector layer **320** having a light detector **322**. The layers or made of suitable material(s) and thickness(es). Although FIG. 3 shows a multi-layer body **300**, the body **300** may be a single, monolithic structure in other embodiments. Also, although the body **300** in FIG. 3 has certain layers, other embodiments may integrate, omit, or add one or more layers or change the location of one or more layers in the body **300**. For example, the body **300** may omit the filter layer **310** in non-photoluminescence applications. As another example, the body **300** may include a

transparent protective layer (not shown) outside the filter layer **310** to isolate the filter layer **310** and/or the light detector **322**. As another example, the body **300** may include the surface element **250** as a surface layer of the body **300**. In yet another example, the body **300** may include a lens **302** (shown in **FIG. 3**) between the surface element **250** and the filter layer **310**.

[0082] The body **300** may be fabricated using standard semiconductor and micro/nanofabrication procedures. During an exemplary fabrication of an embodiment of the body **300**, a filter layer **216** can be placed on top of a light detector layer **320**. Then, the lens layer **301** with the lens **302** can be placed on top of the filter layer **312**. After fabrication, the surface element **250** can be located on top of the filter layer **310** during an imaging operation.

[0083] In **FIG. 3**, the filter layer **310** includes a filter **312** (e.g., interference filter, absorption filter, etc.) capable of selectively transmitting light having select light properties (e.g., polarization, wavelength, frequency, intensity, phase, spin angular momentum, etc.) while substantially removing light the remaining light by any suitable method such as reflection, absorption or interference. Some examples of suitable devices include filters (e.g., interference filters, absorption filters, etc.). Any type of filter can be used such as dichroic filters, monochromatic filters, etc. In one embodiment, a polarization filter may be used.

[0084] In a photoluminescence (e.g., fluorescence or phosphorescence) imaging embodiment, the filter layer **310** can be used to transmit emissions from fluorophores in the object **200** and substantially remove excitation light. In this embodiment, the plurality of nondiffracting beams **110** provides an excitation light having an excitation wavelength that can activate fluorophores in the object **200**. The activated fluorophores can emit an emission light (emissions). The emission light can be electromagnetic radiation with specific properties such that it passes through the filter **312** to the light detector **322**. The resulting light data can thus be substantially associated with the emissions from the activated fluorophores in the object **200**.

[0085] In **FIG. 3**, the light detector layer **320** includes a light detector **322** capable of generating one or more signals with light data based on light received by the light detector **322**. Each signal with light data may be in the form of electrical current that from the photoelectric effect. The light detector **322** can detect light having any light property (e.g., wavelength(s), phase(s), intensity(ies), frequency(ies), polarization(s), spin angular momentum(s), and/or other light properties).

[0086] The light detector **322** includes a light detector surface **323**. Although not shown, the light detector **322** also includes a number (e.g., 1, 100, 1000, etc.) of discrete light detecting elements (e.g., pixels). The light detecting elements can be arranged in a suitable form such as a single light detecting element, a one-dimensional array of light detecting elements, a two-dimensional array of light detecting elements, or a multiplicity of one-dimensional and/or two-dimensional arrays of light detecting elements. The arrays can be in any suitable orientation or combination of orientations (e.g., oriented along the x-axis, oriented at an angle with respect to the x-axis, etc.). In some cases, the array(s) of light detecting elements may have the same orientation as the orientation of the plurality of nondiffracting elements **110** and/or are aligned to correspond to the plurality of nondiffracting beams **110**.

[0087] Some examples of light detectors **322** having a single light detecting element include a photo-diode (PD), an avalanche photo-diode (APD) and a photomultiplier tubes (PMT). Some examples of light detectors **322** having one-dimensional or two-dimensional arrays include a charge coupled device (CCD) array, a complementary metal-oxide-semiconductor (CMOS) array, an APD array, a PD array, a PMT array, etc. Suitable light detectors **322** are commercially available.

[0088] Each light detecting element of the light detector **322** may be of any suitable size (e.g., 1-10 microns) and any suitable shape (e.g., circular, square, etc.). For example, a complementary metal-oxide-semiconductor (CMOS) or charge coupled device (CCD) light detecting element may be 1-10 microns and an APD or PMT light detecting element may be as large as 1-4 mm.

[0089] One or more light detecting elements in the light detector **322** may uniquely correspond to each of the nondiffracting beams **110** in some embodiments. For example, each light detecting element may correspond to a unique nondiffracting beam **110**. In this example, the light detecting element may receive light associated with the corresponding nondiffracting beam **110** and generate a signal with light data associated with the light received. In another example, the light detector **322** may be a two dimensional array of light detecting elements (e.g., 100 x 100 array of light detecting elements) that comprises one or more sets of smaller two-dimensional arrays of light detecting elements (e.g., 100 sets of 10 x 10 arrays of light detecting elements). Each set (e.g., 10 x 10 array) can uniquely correspond to a nondiffracting beam **110**. In this example, the each set may receive light associated with

the corresponding nondiffracting beam **110** and generate a signal with light data associated with the light received.

[0090] In FIG. 3, the light detector **322** generates one or more signals with light data associated with the light received by the light detecting elements in the light detector **322**. Light data may include, for example, information about the properties of the light detected such as the intensity of the light, the wavelength(s) of the light, the frequency or frequencies of the light, the polarization(s) of the light, the phase(s) of the light, the spin angular momentum(s) of the light, and/or other light properties associated with the light received. Light data may also include the location of the light detecting element receiving the light. Light data may be data based on a single time, based on multiple times, or based on a time varying basis. Time varying light data refers to light data that is based on a time varying basis.

[0091] At any given time, the light data from the light detector **322** corresponds to a set of discrete transverse (X, Y) points (e.g., scatterers) on the object **200**, with an extended depth (Z) range along the illumination paths of the nondiffracting beams **110**. By using the scanning mechanism **430** to move the nondiffracting beams **110** relative to the object **200** or the object **200** relative to the nondiffracting beams **110**, while continuously acquiring light data from the light detector **322**, the HRID 10 can acquire light data from many to all transverse (X, Y) points of the sample with an extended depth (Z) range. IN this way, the HRID 10 can acquire light data from a sample volume with the object **200**. The HRID can use the light data to acquire high-resolution two-dimensional images of an object **200** in the sample with a wide field of view and an extended depth of focus.

[0092] The surface element **250** may be a component of the HRID **10** or may be separate from the HRID **10**. In addition, the surface element **250** may be a layer of the body **300** or may be a separate component from the body **300**. In the illustrated embodiments shown in FIGS. 1 and 3, the surface element **250** is a separate component from the body **300** that may be removably located proximal the filter layer **310** or coupled to the filter layer **310**. For example, the surface element **250** may be a slide or other platform made of transparent material that can be detachably located on the body **300**. In some cases, the object **200** being imaged can be held (e.g., mounted) to the surface element **250** by an attachment method (e.g., slide cover). In some cases, the surface element **250** may be a translation platform that can be moved by the scanning mechanism **430**. In other embodiments, the surface element **250**

may be a layer of the body **300**. For example, the surface element **250** may be a surface layer of the body **300**. In the illustrated embodiment shown in **FIG. 4**, for example, the surface element **250** is a surface layer of a fluid channel **330** in a multi-layer body **300**.

[0093] The processor **410** may include any suitable processor(s) (e.g., microprocessor) that can receive signals with light data from the light detector **322** associated with the light received by the light detector **322**. The processor **410** can generate a high resolution two-dimensional image of the object **200** or a portion of the object **200** based on the light data received from the light detector **322**. The processor **410** executes code stored on the CRM **420** to perform some of the functions of HRID **10** such as interpreting the light data from the light detector **322**, performing analyses of the light data, and generating one or more images of the object **200** based on the light data.

[0094] The CRM (e.g., memory) **420** stores code for performing some functions of the HRID **10**. The code is executable by the processor **410**. In some embodiments, the CRM **420** may comprise: a) code for interpreting light data received from the light detector **322**, b) code for generating one or more images of the object **200** based on non-time varying light data, c) code for determining the propagation angle of one or more nondiffracting beams **110**, d) code for compiling line scans or other time varying light data into a two-dimensional image of the object based on the time varying light data, e) code for displaying the generated images, f) and/or any other suitable code for performing functions of the HRID **10**. The CRM **420** may also include code for performing any of the signal processing or other software-related functions that may be created by those of ordinary skill in the art. The code may be in any suitable programming language including C, C++, Pascal, etc.

[0095] The HRID **10** can be used to generate any suitable type of image such as a fluorescence image, phosphorescence image, intensity images, phase image, differential interference contrast (DIC) image, etc. The images can be black and white images, grey tone images, color images, etc.

[0096] In one embodiment, the HRID **10** can generate a photoluminescence (e.g., fluorescence or phosphorescence) image of the object **200**. In this embodiment, the filter layer **310** includes any suitable device(s) (e.g., optical filter) that can reject excitation light and pass emission light from the fluorophores. The illumination source **120** (e.g., laser) provides an excitation light having an excitation wavelength that can excite fluorophores in the object **200**. The excited fluorophores emit an emission light. The light data measured by

the light detector **322** is associated with the emission light from the fluorophores in the object **200**. The processor **410** generates image data associated with the emission light data and generates a photoluminescence image of the object **200** based on the image data.

[0097] Modifications, additions, or omissions may be made to HRID **10** without departing from the scope of the disclosure. For example, the HRID **10** may omit the filter layer **132** in embodiments of the HRID **10** which do not perform photoluminescence imaging. As another example, other embodiments of the HRID **10** may include a display communicatively coupled to the processor **410** to receive output data such as image data and provide output such as an image or image data to a user of the HRID **10**. In addition, the components of HRID **10** may be integrated or separated according to particular needs. For example, the processor **410** or other suitable processor may be integrated into the light detector **322** so that the light detector **322** can perform one or more of the functions of the processor **410** in some embodiments. As another example, the processor **410** and/or CRM **420** may be components of a computer, which is separate from the HRID **10** or a component of the HRID **10**. As another example, the processor **410** and/or CRM **20** may be separate from the HDID **10**.

[0098] **C. Optofluidic Application**

[0099] In optofluidic embodiments, an HRID **10** uses optofluidic flow as a scanning mechanism to provide a highly compact, inexpensive, and robust device with highly automatable, high-throughput, high-resolution imaging with wide field and extended focus. In these embodiments, the HRID **10** acquires an image of an object **200** as the object **200** moves in a fluid flow through a fluid channel (optofluidic application). Either direct imaging or projection imaging schemes can be employed in these embodiments.

[0100] **FIG. 4** is a schematic drawing of components of a HRID **10** using optofluidic flow as a scanning mechanism and employs the direct imaging scheme to generate two-dimensional high resolution images of an object **200**, according to embodiments of the invention. The HRID **10** includes a beam generator **100** having an illumination source **120** providing an excitation beam **130**, a holographic element **140** generating the plurality of nondiffracting beams **110** when illuminated by the excitation beam **130**, and a beam generator surface **102**. The plurality of nondiffracting beam **110** is in the form of a one-dimensional array. An object **200** being imaged is located between the surface element **250** and the beam generator **100**. The HRID **10** also includes a body **300**. The body **300** includes

the holographic element **140**, a surface element **110** having a first surface **252**, a filter layer **310** having a filter **312** and a light detector layer **320** having a light detector **322**. The body **300** also defines or includes a fluid channel **300** having a longitudinal axis. The HRID **10** also includes a processor **410** communicatively coupled to the light detector **322**, and a computer readable medium **420** communicatively coupled to the processor **410**.

[0101] The HRID **10** also includes an x-axis, a y-axis, and a z-axis. The x-axis and y-axis lie in the plane of the first surface **252** of the surface element **250**. The z-axis is orthogonal to this plane.

[0102] In **FIG. 4**, the beam generator **100** generates a plurality of nondiffracting beams **110** (e.g., Bessel beams) in the form of a one-dimensional array **111**. Each nondiffracting beam **110** has little to no diffraction with propagation. For example, as each nondiffracting beam **110** propagates, the nondiffracting beam **110** does not substantially diffract and maintains a tight focus confining photons within a narrow width and sustaining constant width over a relatively long section of the beam's axis.

[0103] The nondiffracting beam **110** can have any suitable light property (intensity, phase, etc.) and any suitable size (spot size, length, etc.). For example, the nondiffracting beam **110** may have a substantially constant spot size of less than a micron in diameter (e.g., submicron size). As another example, the nondiffracting beam **110** may have a length of 250 microns or greater. An illustrated example of a Bessel beam having a length of approximately 200 microns is shown in **FIG. 2(a)**.

[0104] In **FIG. 4**, the plurality of nondiffracting beams **110** is arranged in a one-dimensional array having 29 x 1 dimensions and is oriented at an angle, α with respect to the x-axis. The nondiffracting beams **110** in the array, as a group, substantially extend from the first lateral side **336** to the second lateral side **338** of the fluid channel **330**. In other embodiments, other suitable number of nondiffracting beams **110** can be used (e.g., 1, 50, 100, 200, 1000, etc.) and/or other suitable arrangements (e.g., a two-dimensional array, a three-dimensional array, and a multiplicity of one-dimensional, two-dimensional, and/or three-dimensional arrays of any suitable dimensions) can be used. In addition, the arrays of other embodiments can have another suitable orientation or orientations.

[0105] Each of the nondiffracting beams **110** has an illumination path which lies substantially along a line. In **FIG. 4**, the nondiffracting beams **110** lie in the z-direction and have illumination paths that lie substantially along z-directional lines at a set of discrete

transverse (X, Y) locations across a portion of the surface element **250**. In other embodiments, the nondiffracting beams **110** may lie at an angle to the z-axis.

[0106] In **FIG. 4**, the beam generator **100** includes a holographic element (e.g., holographic plate) **140** in communication with an illumination source (e.g., laser) **130** providing an excitation beam **130** (e.g., plane wave excitation beam). The holographic element **140** generates the plurality of nondiffracting beams **110** upon being illuminated by the excitation beam **130**. In other embodiments, another suitable device or combination of devices can be used to generate the plurality of nondiffracting beams **110**. Some examples of suitable devices are described in Section III below.

[0107] The illumination source **120** in **FIG. 4** may be any suitable device(s) capable of providing an excitation beam **130**. Some examples of suitable devices include light-emitting diodes (LEDs), laser of suitable wavelength, broadband source (e.g., mercury lamp, halogen lamp, etc.) with a suitable filter, natural light, etc. Suitable illumination sources are commercially available. The illumination source **120** may be placed in any location and at any orientation that allows it to generate an appropriate excitation beam **130** at the holographic element **140**. The illumination source **120** may provide an appropriate excitation beam **130** of a suitable wavelength, intensity, phase, polarization, spin angular momentum or other light property, and spatial distribution. The illumination source **120** may provide a coherent, incoherent, or partially coherent excitation beam **130**. In exemplary fluorescence/phosphorescence embodiments, the illumination source **120** provides excitation light having a first light property (e.g., first wavelength) matching the excitation wavelength of the fluorophores in an object **200** being imaged by the HRID **10**. The fluorophores are excited by the excitation light and emit light (emissions) of a second light property (e.g., second wavelength). Some examples of suitable excitation light include fluorescence, 2-photon or higher order fluorescence, Raman, second harmonic or higher order, or other emission mechanism that results in emissions at a different wavelength or other different light property than the excitation light. Although the illumination source **120** in **FIG. 1** is a component of the HRID **10**, the illumination source **120** may be separate from the HRID **10** in other embodiments.

[0108] In **FIG. 4**, the holographic element **140** is a CGH capable of converting an excitation beam **130** (e.g., plane wave excitation beam) from an illumination source **120** into the plurality of nondiffracting beams **110**. The holographic element **140** can be made of any

suitable material or materials. Some examples of suitable holographic materials include photographic emulsions, dichromated gelatin, and photoresists. The holographic element **140** can have any suitable dimensions (e.g., 1 mm x 1 mm, 2 mm x 2 mm, 5 mm x 2 mm, 10 mm x 10 mm, 10 mm x 50 mm, etc.). In the case of an optically recorded hologram, the holographic element **140** can be made using any holographic recording technique capable of encoding (recording) data about the plurality of nondiffracting beams **110**. Some examples of suitable holographic recording techniques include in-line (Gabor) and off-axis (Leith-Upatnieks). To play back the recording, the holographic element **140** can be illuminated by an excitation beam **130** having the same wavelength, same spatial distribution, but not necessarily the same intensity, as the reference beam used to record the holographic element **140**. In many embodiments, the holographic element **140** is a CGH that is designed to generate a plurality of well-separated nondiffracting beams **110** upon being illuminated by a plane wave excitation beam **130**. Some examples of suitable CGHs are described in Section III below.

[0109] In optofluidic embodiments, the scanning mechanism **430** includes the structural elements of the fluid channel **330** having a fluid flow for moving the object **200** being imaged relative to the plurality of nondiffracting beams **110**. In these embodiments, the scanning mechanism **430** is similar to the scanning mechanism used in optofluidic microscopy, where an image is acquired as an object **200** moves in a fluid flow through a fluid channel **330**. An example of a scanning mechanism used in optofluidic microscopy can be found in X. Heng, D. Erickson, L. R. Baugh, Z. Yaqoob, P. W. Sternberg, D. Psaltis, and C. H. Yang, "Optofluidic microscopy - a method for implementing a high resolution optical microscope on a chip," Lab on a Chip 6, 1274-1276 (2006).

[0110] Any suitable object **200**, objects **200**, or portion of an object **200** may be imaged by the HRID **10**. Typically, the HRID **10** images an object **200** within a fluid sample introduced into the fluid channel **330** of the HRID **10**. Suitable objects **200** can be biological or inorganic entities. Examples of biological entities include whole cells, cell components, microorganisms such as bacteria or viruses, cell components such as proteins, etc. Inorganic entities may also be imaged by embodiments of the invention. Examples of inorganic entities include mineral fibers, and crystals. The object **200** can have any thickness.

[0111] In FIG. 4, the plurality of nondiffracting beams **110** can illuminate through the entire depth of the fluid channel **330** and the object **200** in the fluid channel **330**. Using the

fluid flow to carry the fluid sample through the plurality of nondiffracting beams **110**, a fluid sample volume can be illuminated by the plurality of nondiffracting beams **110**. The fluid sample volume may include at least a portion of the volume of the object **200** being imaged. In many embodiments, the entire sample volume including the volume of the object **200** may be illuminated by the plurality of nondiffracting beams **110**.

[0112] In **FIG. 4**, the HRID **10** includes a multi-layer body **300** comprising a holographic element **140**, a surface element **250**, a filter layer **310** having a filter **312** and a light detector layer **320** having a light detector **322**. Although **FIG. 4** shows a multi-layer body **300**, the body **300** may be a single, monolithic structure in other embodiments. In the illustrated optofluidic example of **FIG. 4**, the surface element **250** is a surface layer (e.g., transparent surface layer) of the body **300**. The layers of the body **300** may be of any suitable material or combination of materials having any suitable thickness or thicknesses. The layers of the body **300** may also include any suitable device (e.g., light detector **322**) or structural element such as a fluid channel **330**.

[0113] The body **300** also defines or includes a fluid channel **330**. The fluid channel **330** can have a fluid flow moving the object **200** being imaged through one or more of the nondiffracting beams **110**. The fluid channel **330** has a first channel surface **332** and a second channel surface **334** on opposite sides of the fluid channel **330**. In the illustrated example, the first channel surface **332** is coincident with the first surface **252** of the surface element **250** and the second channel surface **334** is coincident with the beam generator surface **102**. In other embodiments, a transparent layer may lie between the first surface **252** and the first channel surface **332** and/or a transparent layer may lie between the beam generator surface **102** and the second channel surface **334**. In **FIG. 4**, the fluid channel **330** also has a first lateral side **336** and a second lateral side **338** opposing the first lateral side.

[0114] The fluid channel **330** may have any suitable dimensions. For example, the width and/or depth of the fluid channel **330** may each be less than about 10 microns, 5 microns, or 1 micron. In some cases, the fluid channel **330** may be sized based on the size of the object **200** being imaged by the HRID **10**. The fluid channel **330** can also have any suitable cross-sectional shape (e.g., oval, rectangle, square, etc.). In the illustrated embodiment, the nondiffracting beams propagate through the depth of the fluid channel **330**.

[0115] In an optofluidic application, the fluid flow in the fluid channel **330** is generally in the direction of the x-axis along a longitudinal axis of the fluid channel **330**.

Any suitable technique may be used for providing fluid flow and particulate transport of the objects **200** in the fluid channel **330** of these embodiments. Some convention techniques include pressure drive flow, electrokinetic transport, discrete droplet translocation via electrowetting, or thermocapilarity techniques. Other techniques may include gravity drive flow, hydrodynamic focusing, dielectrophoresis, and optical tweezing. Any suitable control device(s) may be used to control the flow of fluid and/or movement of the object **200** through the fluid channel **330**. Some examples of suitable control devices include micropumps, direct current (DC) electrokinetic devices, dielectrophoresis electrodes, and/or hydrodynamic focusing channels.

[0116] In **FIG. 4**, the filter layer **310** includes a filter **312** (e.g., interference filter, absorption filter, etc.) capable of selectively transmitting light having select light properties (e.g., polarization, wavelength, frequency, intensity, phase, spin angular momentum, etc.) while substantially removing light the remaining light by any suitable method such as reflection, absorption or interference. Some examples of suitable devices include filters (e.g., interference filters, absorption filters, etc.). Any type of filter can be used such as dichroic filters, monochromatic filters, etc. In one embodiment, a polarization filter may be used.

[0117] In a photoluminescence (e.g., fluorescence or phosphorescence) imaging embodiment, the filter layer **310** can be used to transmit emissions from fluorophores in the object **200** and substantially remove excitation light. In this embodiment, the plurality of nondiffracting beams **110** provides an excitation light having an excitation wavelength that can activate fluorophores in the object **200**. The activated fluorophores can emit an emission light (emissions). The emission light can be electromagnetic radiation with specific properties such that it passes through the filter **312** to the light detector **322**. The resulting light data can thus be substantially associated with the emissions from the activated fluorophores in the object **200**.

[0118] In **FIG. 4**, the light detector layer **320** includes a light detector **322** capable of generating one or more signals with light data based on light received by the light detector **322**. Each signal with light data may be in the form of electrical current that from the photoelectric effect. The light detector **322** includes a light detector surface **323**. The light detector **322** can detect light having any light property (e.g., wavelength(s), phase(s), intensity(ies), frequency(ies), polarization(s), spin angular momentum(s), and/or other light properties).

[0119] Although not shown, the light detector **322** includes a suitable number (e.g., 1, 100, 1000, etc.) of discrete light detecting elements (e.g., pixels). The light detecting elements can be arranged in a suitable form such as a single light detecting element, a one-dimensional array of light detecting elements, a two-dimensional array of light detecting elements, or a multiplicity of one-dimensional and/or two-dimensional arrays of light detecting elements. The arrays can be in any suitable orientation or combination of orientations (e.g., oriented along the x-axis, oriented at the angle with respect to the x-axis, etc.). In some cases, the array(s) of light detecting elements may have the same orientation as the orientation of the plurality of nondiffracting elements **110** and/or are aligned to correspond to the plurality of nondiffracting beams **110**. For example, the light detector **322** in **FIG. 4** may include an array or arrays of light detecting elements oriented at an angle, α with respect to the x-axis to correspond to the one-dimensional array 111 of nondiffracting beams having the same orientation.

[0120] Some examples of light detectors **322** having a single light detecting element include a photo-diode (PD), an avalanche photo-diode (APD) and a photomultiplier tubes (PMT). Some examples of light detectors **322** having one-dimensional or two-dimensional arrays include a charge coupled device (CCD) array, a complementary metal-oxide-semiconductor (CMOS) array, an APD array, a PD array, a PMT array, etc. Suitable light detectors **322** are commercially available.

[0121] Each light detecting element of the light detector **322** may be of any suitable size (e.g., 1-10 microns) and any suitable shape (e.g., circular, square, etc.). For example, a complementary metal-oxide-semiconductor (CMOS) or charge coupled device (CCD) light detecting element may be 1-10 microns and an APD or PMT light detecting element may be as large as 1-4 mm.

[0122] In some optofluidic embodiments, one or more light detecting elements in the light detector **322** may uniquely correspond to a nondiffracting beam **110** in the one-dimensional array. For example, one or more light detecting elements located at a distance from the y-axis may uniquely correspond to the nondiffracting beam **110** located at the distance from the y-axis. As another example, one or more light detecting elements located within a range of distances from the y-axis may uniquely correspond to the nondiffracting beam **110** located within that range of distances from the y-axis. In these cases, the light detecting element may receive light associated with the corresponding nondiffracting beam

110 and generate a signal with light data associated with the light received. In another example, the light detector **322** may be a two dimensional array of light detecting elements (e.g., 100 x 29 array of light detecting elements) that comprises sets of one-dimensional arrays of light detecting elements (e.g., 29 sets of 100 x 1 arrays of light detecting elements). Each set (e.g., 100 x 1 array) can correspond to a unique nondiffracting beam **110** in a one-dimensional array **111** of nondiffracting beams **110**. In another example, the light detector **322** may be a two dimensional array of light detecting elements (e.g., 100 x 87 array of light detecting elements) that comprises sets of one-dimensional arrays of light detecting elements (e.g., 29 sets of 100 x 3 arrays of light detecting elements). Each set (e.g., 100 x 3 array) can correspond to a unique nondiffracting beam **110** in a one-dimensional array **111** of nondiffracting beams **110**. In these two examples, the each set may receive light associated with the corresponding nondiffracting beam **110** and generate a signal with light data associated with the light received.

[0123] The light detector **322** generates one or more signals with light data associated with the light received by the light detecting elements in the light detector **322**. Light data may include, for example, information about the properties of the light detected such as the intensity of the light, the wavelength(s) of the light, the frequency or frequencies of the light, the polarization(s) of the light, the phase(s) of the light, the spin angular momentum(s) of the light, and/or other light properties associated with the light received. Light data may also include the location of the light detecting element receiving the light.

[0124] In **FIG. 4**, the light detecting elements generate a signal with time varying light data as the object **200** moves in the fluid channel **330** and passes through the illuminating beams **330**. Time varying light data refers to light data that is based on a time varying basis. In one example, the time varying data is in the form of line scans.

[0125] At any given time, the time varying data from the light detector **322** corresponds to a set of discrete transverse (X, Y) points (e.g., scatterers) on the object **200**, with an extended depth (Z) range along the illumination paths of the nondiffracting beams **110**. By moving the object **200** relative through the nondiffracting beams **110**, while continuously acquiring time varying light data (e.g., line scans) from the light detector **322**, the HRID **10** can acquire time varying light data from all transverse (X, Y) points of the sample with an extended depth (Z) range and thus acquire time varying light data from the sample volume with an object volume. In this way, the HRID **10** can acquire high-resolution

two-dimensional images of an object **200** in the sample with a wide field of view and an extended depth of focus.

[0126] Although the body **300** in **FIG. 4** has certain layers, other embodiments may integrate, omit, or add one or more layers or change the location of one or more layers in the body **300**. For example, the body **300** may omit the filter layer **310**. As another example, the body **300** may include a transparent protective layer (not shown) outside the filter layer **310** to isolate the filter layer **310** and/or the light detector **322**. In yet another example or an embodiment using the projection imaging scheme, the body **300** may include a lens between the surface element **250** and the filter layer **310**. In another example, the holographic element **140** and/or the surface element **250** may be separate from the body **300**. In this example, one or more transparent layers may be used as surface layers to define the fluid channel **330**.

[0127] The body **300** may be fabricated using standard semiconductor and micro/nanofabrication procedures. During an exemplary fabrication of an embodiment of the body **300**, a filter layer **310** can be placed on top of the light detector layer **320**. Then, then surface element **250** may be placed on top of the filter layer **310**. The fluid channel **330** and holographic element **140** can then be placed on top of the surface element **250**.

[0128] The processor **410** may include any suitable processor(s) (e.g., microprocessor) that can receive signals with light data from the light detector **322** associated with the light received by the light detector **322**. The processor **410** can generate a high resolution two-dimensional image of the object **200** or a portion of the object **200** based on the light data received from the light detector **322**. The processor **410** executes code stored on the CRM **420** to perform some of the functions of HRID **10** such as interpreting the light data from the light detector **322**, performing analyses of the light data, and generating one or more images of the object **200** based on the light data.

[0129] The CRM (e.g., memory) **420** stores code for performing some functions of the HRID **10**. The code is executable by the processor **410**. In some embodiments, the CRM **420** may comprise: a) code for interpreting light data received from the light detector **322**, b) code for generating one or more images of the object **200** based on non-time varying light data, c) code for determining the propagation angle of one or more nondiffracting beams **110**, d) code for compiling line scans or other time varying light data into a two-dimensional image of the object based on the time varying light data, e) code for displaying the generated images, f) and/or any other suitable code for performing functions of the HRID **10**. The

CRM **420** may also include code for performing any of the signal processing or other software-related functions that may be created by those of ordinary skill in the art. The code may be in any suitable programming language including C, C++, Pascal, etc.

[0130] During operation of an optofluidic embodiment, a fluid, within which the object **200** is suspended, flows through the fluid channel **330**. As the object **200** flows through the fluid channel **330**, the object **200** alters (blocks, reduces intensity, modifies wavelength or other light property or spatial distribution) the light in the fluid channel **330**. FIG. 4 shows the object **200** at a specific time as the object **200** moves through the array of nondiffracting beams **110**.

[0131] In the illustrated embodiment, one or more light detecting elements in the light detector **322** receive light associated with a single nondiffracting beam **110**. The light detecting elements receive light and generate time varying light data about the light as the object **200** moves through the fluid channel **330**. The processor **410** receives a signal with time varying light data. The processor **410** uses the time varying light data to generate line scans associated with the y-locations of the light detecting elements. Each line scan is associated with a nondiffracting beam **110**. The processor **410** can also use the light data to determine the rotation, velocity of the object **200**, and changes in shape of the object **200**. The time varying light data from the light detecting elements is based on the illumination through a volume of the object **150** illuminated by the nondiffracting beams **100**. The processor **410** can reconstruct an image of the object **200** by appropriately shifting and assembling the line scans, and optionally other data such as rotation, velocity of the object **200**, and changes in shape of the object **200**, etc.

[0132] The HRID **100** can be used to generate any suitable type of image such as a fluorescence image, phosphorescence image, intensity images, phase image, differential interference contrast (DIC) image, etc. The images can be black and white images, grey tone images, color images, etc.

[0133] In one embodiment, the HRID **10** can generate a photoluminescence (e.g., fluorescence or phosphorescence) image of the object **200**. In this embodiment, the filter layer **310** includes any suitable device(s) (e.g., optical filter) that can reject excitation light and pass emission light from the fluorophores. The illumination source **120** (e.g., laser) provides an excitation light having an excitation wavelength that can excite fluorophores in the object **200**. The excited fluorophores emit an emission light. The light data measured by

the light detector **322** is associated with the emission light from the fluorophores in the object **200**. The processor **410** generates image data associated with the emission light data and generates a photoluminescence image of the object **200** based on the image data.

[0134] Modifications, additions, or omissions may be made to HRID **10** without departing from the scope of the disclosure. For example, the HRID **10** may omit the filter layer **132** in embodiments of the HRID **10** which do not perform photoluminescence imaging. As another example, other embodiments of the HRID **10** may include a display communicatively coupled to the processor **410** to receive output data such as image data and provide output such as an image or image data to a user of the HRID **10**. In addition, the components of HRID **10** may be integrated or separated according to particular needs. For example, the processor **410** or other suitable processor may be integrated into the light detector **322** so that the light detector **322** can perform one or more of the functions of the processor **410** in some embodiments. As another example, the processor **410** and/or CRM **420** may be components of a computer, which is separate from the HRID **10** or a component of the HRID **10**. As another example, the processor **410** and/or CRM **20** may be separate from the HRID **10**.

[0135] **D. Exemplary Operation of HRID**

[0136] **FIG. 7** is a flow chart of an exemplary method of imaging with the HRID **10**, according to embodiments of the invention. In **step 510**, a sample (specimen) with one or more objects **200** is introduced into the HRID **10** using any suitable method. In an optofluidic embodiment, for example, the object **200** may be in a sample fluid injected into an input port of the fluid channel **300** (shown in **FIG. 4**) of the HRID **10**. In another embodiment, the object **200** can be mounted or otherwise located on a removable surface element **250** (e.g., translation stage for providing the scanning for imaging), which is placed onto the body **300** of the HRID **10**.

[0137] In **step 520**, a beam generator **100** creates a plurality of nondiffracting beams **110** that propagate through the one or more objects **200** while maintaining a constant spot size. The beam generator **100** can include any suitable device to generate the appropriate nondiffracting beams **110**. For example, the beam generator **110** can include a holographic element **140** (e.g., CGH) that can generate the plurality of nondiffracting beams **110** upon being illuminated by the excitation beam **130** (e.g., plane wave excitation beam) from an

illumination source **120** (e.g., laser). In other embodiments, other suitable devices can be used, as described in Section III.

[0138] To acquire an image of an object **200**, the HRID **10** illuminates a volume of the sample (sample volume) including the one or more objects **200** being imaged. The HRID illuminates the sample volume using a scanning mechanism **430** (step **530**). Any suitable scanning mechanism can be used. In some embodiments, the scanning mechanism **430** is a scanning device (e.g. raster scanner) that can scan the surface element **250** with the object **200** through the nondiffracting beams **110** or scan the nondiffracting beams **110** through a volume of the sample. In other embodiments, the scanning mechanism **430** can be a mechanism similar to the one used in optofluidic microscopy, where an image can be acquired by linear scanning. In these embodiments, the scanning mechanism **430** includes a fluid channel **330** having a fluid flow. The fluid flow carries a fluid specimen with the one or more objects **200** through an array of nondiffracting beams **110** diagonally located from one lateral side to the other lateral side of the fluid channel **330**.

[0139] In step **540**, the one or more objects **430** alter the light from the nondiffracting beams **110**. In step **550**, the light detector **322** receives light. The light is associated with the plurality of nondiffracting beams **110** as the scanning mechanism **430** moves the one or more objects **200** relative to the nondiffracting beams **110** or the nondiffracting beams **110** relative to the one or more objects **200**. In a projection imaging embodiment, the HRID **10** includes a lens **302** between the light detector **322** and the surface element **250** that projects the light to the light detector **322**. In a photoluminescence imaging embodiment, the filter **312** in the filter layer **310** blocks excitation light and passes emissions from fluorophores in the one or more object **200**. In bright field imaging, the HRID **10** may not have a filter layer **310**.

[0140] In step **560**, the light detector **322** generates one or more signals with light data (e.g., time varying light data) associated with the light received, as the scanning mechanism **430** moves the plurality of nondiffracting beams **110** through the volume of the object **200** or moves the volume through the plurality of nondiffracting beams **110**. At any given time during the scanning, the light data from the light detector **322** corresponds to a set of discrete transverse (X, Y) points on the object **200**, with an extended depth (Z) range. That is, the light data corresponds to the illumination paths of the nondiffracting beams **110** which lie along z-directional lines at the set of discrete transvers (X, Y) points. By scanning, while continuously acquiring light data from the light detector **322**, the HRID **10** is enabled to

sample most to all transverse (X, Y) points in the sample volume and consequently be able to generate a continuous high-resolution two-dimensional image of the one or more objects **200** with a wide field of view and an extended depth of focus.

[0141] In **step 570**, the processor **410** receives the one or more signals with the light data from the light detector **322** and executes code on the CRM **420** to process the light data to generate one or more high resolution images of the one or more objects **200** with a wide field of view and an extended depth of focus. The HRID **100** can generate any suitable type of images such as a fluorescence images, phosphorescence images, intensity images, phase images, differential interference contrast (DIC) images, etc. The images can be black and white images, grey tone images, color images, etc.

[0142] In an optofluidic embodiment, the light data is time varying light data and the processor **410** uses the time varying light data to generate line scans associated with the y-locations of the light detecting elements. The processor **410** can also use the light data to determine the rotation, velocity of the object **200**, and changes in shape of the object **200**. Each line scan is associated with a nondiffracting beam **110**. The time varying light data from the light detecting elements is based on the illumination through a volume of the object **150** illuminated by the nondiffracting beams **100**. The processor **410** can reconstruct an image of the object **200** by appropriately shifting and assembling the line scans, and optionally other data such as rotation, velocity of the object **200**, and changes in shape of the object **200**, etc.

[0143] **III. Beam Generators**

[0144] The HRID **10** includes a beam generator **100** which can include any device or combination of any devices capable of generating the plurality of nondiffracting beams **110**. Some examples of suitable device(s) in the beam generator **100** of embodiments may include: 1) a holographic element **140** (e.g., CGH) coupled to an illumination source **120** generating an excitation beam (e.g., plane wave excitation beam) **130**, 2) one or more microaxicons, 3) one or more optical fibers, and 4) one or more optical fibers fitted with microaxicons. Although the first example is illustrated in **FIGS. 1, 3 and 4**, any suitable beam generating device can be included in other embodiments.

[0145] **A. Holographic Element (e.g., CGH)**

[0146] In some embodiments, the beam generator **100** may include a holographic element **140** coupled to an illumination source **120** generating an excitation beam (e.g., plane wave excitation beam) **130**. The holographic element **140** may be, for example, a CGH. In some cases, such as the illustrated embodiments shown in **FIGS. 1, 3, and 4**, the holographic element **140** may be a custom designed CGH for generating a plurality of well separated nondiffracting beams **110**, upon being illuminated by a plane wave excitation beam **130** (excitation beam). The custom-designed CGH of these embodiments can be designed so that adjacent nondiffracting beams **110** are sufficiently separated to reduce or avoid crosstalk/multiplexing between beams, which can affect the quality of the nondiffracting beam illumination. The custom designed CGH (e.g., custom-designed CGH) can be designed to generate one or more nondiffracting beams **110** that do not diffract or only minimally diffracts within a limited region of space. The custom designed CGH can be computationally designed by interfering a conical wave front with a plane wave. The spot size and the focal plane of each nondiffracting beam **110** may be controlled by adjusting the width and the peak phase retardation of the conical wave front. By spatially shifting and summing these interference patterns, a series of Bessel beams can be generated. Depending on resolution requirements, the custom designed CGH can either be printed with grayscale graphics printers, with photoplotters as halftone images, or can be fabricated as chrome/iron oxide binary photomasks. An example of a custom-designed CGH can be found in “The generation of an array of nondiffracting beams by a single composite computer generated hologram,” S H Tao et al 2005 J. Opt. A: Pure Appl. Opt. 7 40, which is hereby incorporated by reference in its entirety for all purposes. In this example, the CGH includes an $N \times N$ array of holograms, each hologram generating an individual Bessel beam. The CGH in this example can be used to generate a two-dimensional ($N \times N$) array of Bessel beams. In this example, the holograms are designed to generate Bessel beams with sufficient separation to avoid crosstalk. Another example of a custom-designed CGH can be found in “Holographic generation of diffraction-free beams, Jari Turunen, Antti Vasara, and Ari T. Friberg, Appl. Opt. 27, 3959-3962 (1988),” S H Tao et al 2005 J. Opt. A: Pure Appl. Opt. 7 40, which is hereby incorporated by reference in its entirety for all purposes.

[0147] **FIG. 5** is an illustration of an amplitude CGH for generating nine nondiffracting beams **110**, according to embodiments of the invention. The CGH illustrated in **FIG. 5** is an example of a holographic element **140** of a beam generator **100** of embodiments. In **FIG. 5**, the CGH is shown to be able to generate nine nondiffracting beams

110 with the following parameters: spot size = 1 μm , separation between beams = 64 μm , CGH-focus distance = 160 μm , and wavelength = 0.5 μm . When illuminated with a spatially coherent excitation beam **130**, the illustrated CGH can form nine nondiffracting beams **110** after an axial distance of 160 μm from it. **FIG. 6** is an illustration of the nine nondiffracting beams **110** generated by the amplitude CGH shown in **FIG. 5**, according to embodiments of the invention.

[0148] Depending on resolution requirements, an amplitude CGH such as illustrated in **FIG. 5**, can either be printed with grayscale graphics printers, with photoplotters as halftone images, or can be fabricated as chrome/iron oxide binary photomasks. Typically, the printing resolution requirement scales with the desired resolution of the HRID **10**. For example, to generate nondiffracting beams **110** with 1 μm spot size, the smallest feature size in our CGH is of the order of 1 μm . In this case, the resolution of printing technique used should be at least 1 μm . Such high resolution CGHs may be fabricated as binary chrome/iron oxide photo masks. While it may be expensive to fabricate the master chrome mask, copies of the master can be readily recorded either as optical holograms, or be duplicated using standard photolithography and/or photoreduction techniques.

[0149] **B. Microaxicon(s)**

[0150] In some embodiments, a beam generator **100** may include one or more microaxicons for generating the plurality of nondiffracting beams **110**. In some cases, the beam generator **100** may include a two-dimensional microaxicon array. Each microaxicon can generate one or more nondiffracting beams. The fabrication of the two-dimensional microaxicon array can be implemented by multilayer lithography or etching processes. The efficiency of the microaxicon array can be better than a binary CGH since there may be no multiple diffraction in some embodiments. An example of a microaxicon that can generate one or more nondiffracting beams **110** can be found in “Nearly diffraction-limited focusing of a fiber axicon microlens,” Sang-Kee Eah, Wonho Jhe, and Yasuhiko Arakawa, Rev. Sci. Instrum. 74, 4969 (2003).

[0151] **C. Optical Fibers**

[0152] In some embodiments, a beam generator **100** may include one or more optical fibers for generating the plurality of nondiffracting beams **110** in other embodiments. An example of a nondiffracting beam generator comprising a multimode optical fiber device can be found in “Generation of controllable nondiffracting beams using multimode optical

fibers,” Appl. Phys. Lett. 94, 201102 (2009), which is hereby incorporated by reference in its entirety for all purposes. In this example, the multimode optical fiber device includes a laser coupled to a single mode fiber which is coupled to a multimode fiber generating a nondiffracting beam.

[0153] D. Optical Fibers with Microaxicons

[0154] In some embodiments, a beam generator **100** may include optical fibers having microaxicons for generating the plurality of nondiffracting beams **110**. An example of a beam generator comprising optical fibers having an axicon microlens can be found in “Nearly diffraction-limited focusing of a fiber axicon microlens,” Sang-Kee Eah, Wonho Jhe, and Yasuhiko Arakawa, Rev. Sci. Instrum. 74, 4969 (2003), which is hereby incorporated by reference in its entirety for all purposes. In this example, the beam generator includes commercially available single-mode optical fibers. In this example, a microaxicon is fabricated in the end of each optical fiber by selective chemical etching method that allows fine control of the cone angle of the fiber. Light passing through each optical fiber passes through the microaxicon generating a nondiffracting beam and nearly diffraction-limited focused spot.

[0155] IV. Computer devices

[0156] **FIG. 8** is a block diagram of subsystems that may be present in the HRID **10**, according to embodiments of the invention. For example, the HRID **10** includes a processor **410** for processing light data (e.g., time varying light data) and for generating high resolution two-dimensional images of an object **200** with a wide field of view an extended depth of focus. . The processor **410** may be a component of the light detector **322**, in some cases. In other embodiments, the HRID **10** may be in communication with a computer having one or more of the subsystems in **FIG. 8**.

[0157] The various components previously described in the Figures may operate using one or more of the subsystems to facilitate the functions described herein. Any of the components in the Figures may use any suitable number of subsystems to facilitate the functions described herein. Examples of such subsystems and/or components are shown in a **FIG. 8**. The subsystems shown in **FIG. 8** are interconnected via a system bus **675**. Additional subsystems such as a printer **674**, keyboard **678**, fixed disk **679** (or other memory comprising computer readable media), display **676**, which is coupled to display adapter **682**, and others are shown. Peripherals and input/output (I/O) devices, which couple to I/O

controller **671**, can be connected to the computer system by any number of means known in the art, such as serial port **677**. For example, serial port **677** or external interface **681** can be used to connect the computer apparatus to a wide area network such as the Internet, a mouse input device, or a scanner. The interconnection via system bus allows the processor **410** to communicate with each subsystem and to control the execution of instructions from system memory **640** or the fixed disk **679**, as well as the exchange of information between subsystems. The system memory **640** and/or the fixed disk **679** may embody a computer readable medium **420**. Any of these elements may be present in the previously described features. A computer readable medium **420** according to an embodiment of the invention may comprise code for performing any of the functions described above.

[0158] In some embodiments, an output device such as the printer **684** or display **676** of the HRID **10** can output various forms of data. For example, the HRID **10** can output a bright-field image and/or a fluorescence image of an object **200** or other results of analysis.

[0159] It should be understood that the present invention as described above can be implemented in the form of control logic using computer software in a modular or integrated manner. Based on the disclosure and teachings provided herein, a person of ordinary skill in the art will know and appreciate other ways and/or methods to implement the present invention using hardware and a combination of hardware and software.

[0160] Any of the software components or functions described in this application, may be implemented as software code to be executed by a processor using any suitable computer language such as, for example, Java, C++ or Perl using, for example, conventional or object-oriented techniques. The software code may be stored as a series of instructions, or commands on a computer readable medium, such as a random access memory (RAM), a read only memory (ROM), a magnetic medium such as a hard-drive or a floppy disk, or an optical medium such as a CD-ROM. Any such computer readable medium may reside on or within a single computational apparatus, and may be present on or within different computational apparatuses within a system or network.

[0161] A recitation of “a”, “an” or “the” is intended to mean “one or more” unless specifically indicated to the contrary.

[0162] The above description is illustrative and is not restrictive. Many variations of the disclosure will become apparent to those skilled in the art upon review of the disclosure. The scope of the disclosure should, therefore, be determined not with reference to the above

description, but instead should be determined with reference to the pending claims along with their full scope or equivalents.

[0163] One or more features from any embodiment may be combined with one or more features of any other embodiment without departing from the scope of the disclosure. Further, modifications, additions, or omissions may be made to any embodiment without departing from the scope of the disclosure. The components of any embodiment may be integrated or separated according to particular needs without departing from the scope of the disclosure.

[0164] All patents, patent applications, publications, and descriptions mentioned above are hereby incorporated by reference in their entirety for all purposes. None is admitted to be prior art.

WHAT IS CLAIMED IS:

1. A high resolution imaging device with wide field and extended focus, comprising:
 - a beam generator configured to generate a plurality of nondiffracting beams;
 - a scanning mechanism for moving the plurality of nondiffracting beams relative to the object to illuminate a volume of the object;
 - a surface element; and
 - a body comprising a light detector layer outside the surface element, the light detector layer having a light detector configured to measure light data associated with the plurality of nondiffracting beams illuminating the volume of the object.
2. The high resolution imaging device with wide field and extended focus of claim 1, further comprising a processor coupled to the light detector to receive a signal with the light data and generate an image of the object based on the light data received.
3. The high resolution imaging device with wide field and extended focus of claim 1, wherein the body further comprises a lens inside of the light detector layer, the lens configured to focus light on the light detector surface.
4. The high resolution imaging device with wide field and extended focus of claim 3, wherein the lens is located so that the focal plane of the lens is half way through the length of the nondiffracting beams.
5. The high resolution imaging device with wide field and extended focus of claim 3, wherein the lens has a numerical aperture smaller than the plurality of nondiffracting beams.
6. The high resolution imaging device with wide field and extended focus of claim 1, wherein the surface element is a transparent platform holding the object.
7. The high resolution imaging device with wide field and extended focus of claim 1, wherein the body further comprises a filter layer between the light detector layer and the surface element, the filter layer having a filter for passing emissions.

8. The high resolution imaging device with wide field and extended focus of claim 1, wherein the light detector comprises a two-dimensional array of light detecting elements comprising sets of light detecting elements, each set uniquely corresponding to a nondiffracting beam of the plurality of nondiffracting beams.

9. The high resolution imaging device with wide field and extended focus of claim 1, wherein the beam generator comprises a computer generated hologram and an illumination source providing an excitation beam to the computer generated hologram, the computer generated hologram configured to transform the excitation beam into the plurality of nondiffracting beams.

10. The high resolution imaging device with wide field and extended focus of claim 1, wherein the scanning mechanism is a scanner coupled to the beam generator for moving the beam generator relative to the object.

11. The high resolution imaging device with wide field and extended focus of claim 1, wherein the scanning mechanism is a scanner coupled to the surface element holding the object, wherein the scanning mechanism is configured to move the object relative to the nondiffracting beams.

12. A high resolution optofluidic imaging device with wide field and extended focus comprising:

a beam generator configured to generate a plurality of nondiffracting beams;

and

a body comprising:

a fluid channel having a first channel surface and a second channel surface, the fluid channel having a flow moving an object through the nondiffracting beams propagating through the fluid channel,

a surface layer located outside the first channel surface, and

a light detector layer located outside the surface element, the light detector layer having a light detector configured to measure time varying light data associated with the plurality of nondiffracting beams as the object moves through the fluid channel.

13. The high resolution optofluidic imaging device with wide field and extended focus of claim 12, further comprising a processor coupled to the light detector to receive a signal with the time varying light data and generate an image of the object based on the time varying light data received.

14. The high resolution optofluidic imaging device with wide field and extended focus of claim 12, wherein the processor is further configured to generate line scans from the time varying light data.

15. The high resolution optofluidic imaging device with wide field and extended focus of claim 12, wherein the body further comprises a lens inside of the light detector layer, the lens configured to focus light on the light detector surface.

16. The high resolution optofluidic imaging device with wide field and extended focus of claim 15, wherein the lens is located so that the focal plane of the lens is half way through the depth of the fluid channel.

17. The high resolution optofluidic imaging device with wide field and extended focus of claim 15, wherein the lens has a numerical aperture smaller than the plurality of nondiffracting beams.

18. The high resolution optofluidic imaging device with wide field and extended focus of claim 12, wherein the body further comprises a filter layer between the light detector layer and the surface layer, the filter layer having a filter for passing emissions.

19. The high resolution optofluidic imaging device with wide field and extended focus of claim 12, wherein the light detector comprises a two-dimensional array of light detecting elements comprising sets of light detecting elements, each set uniquely corresponding to a nondiffracting beam of the plurality of nondiffracting beams.

20. The high resolution optofluidic imaging device with wide field and extended focus of claim 12, wherein the beam generator comprises a computer generated hologram and an illumination source providing an excitation beam to the computer generated

hologram, the computer generated hologram configured to transform the excitation beam into the plurality of nondiffracting beams.

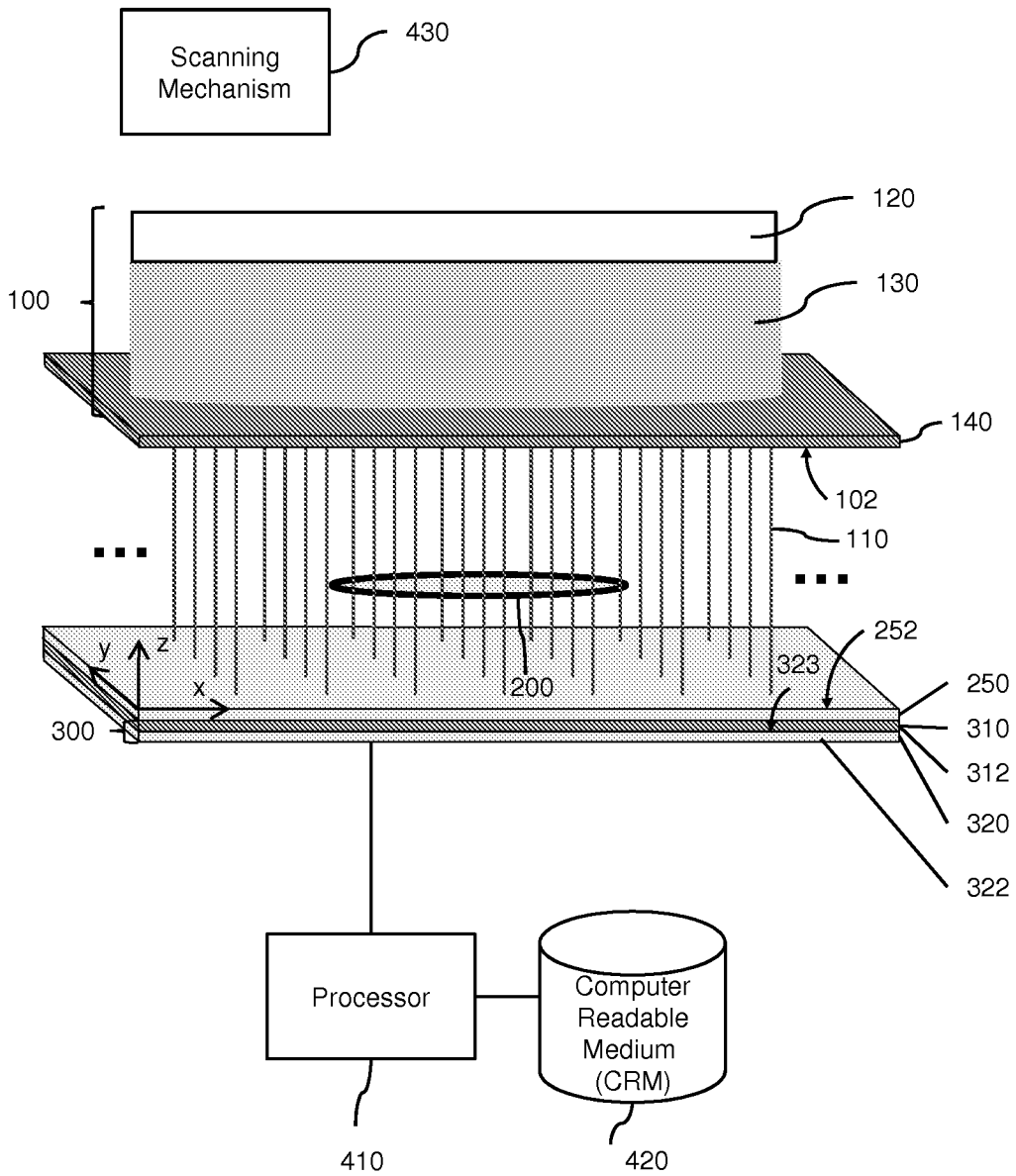

FIG. 1

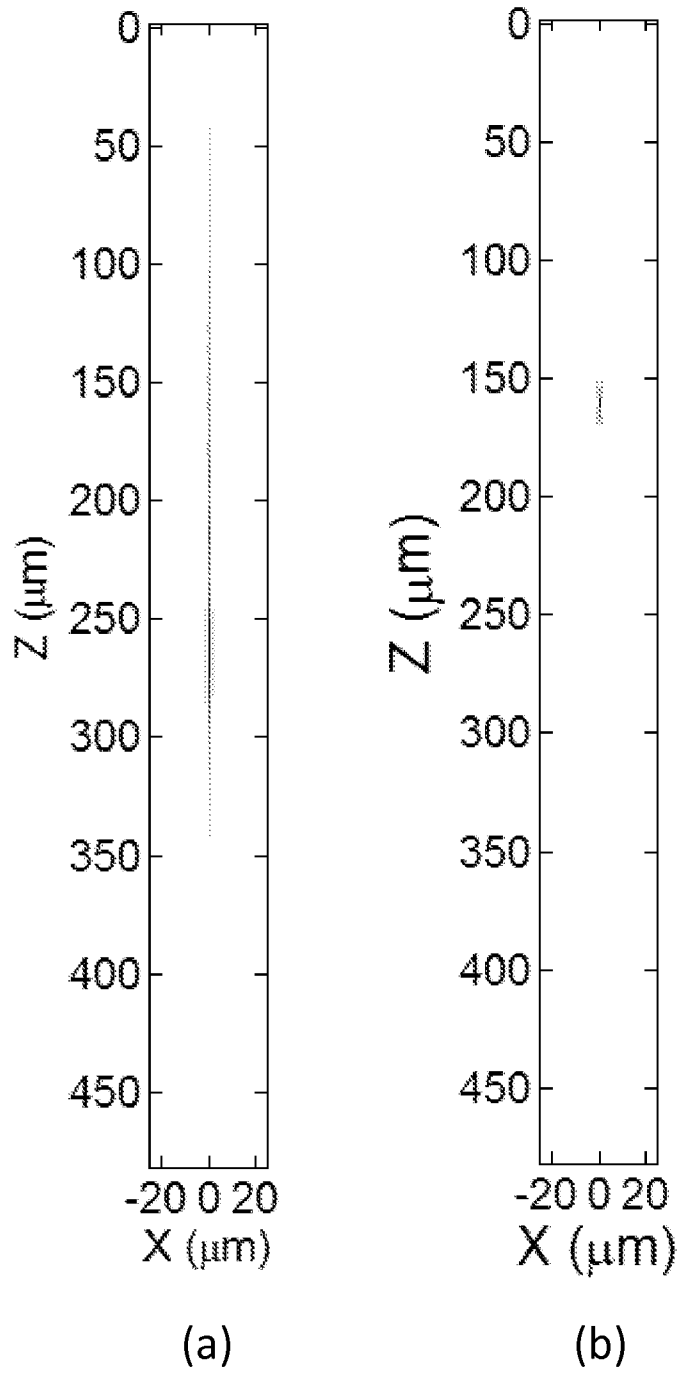

FIG. 2

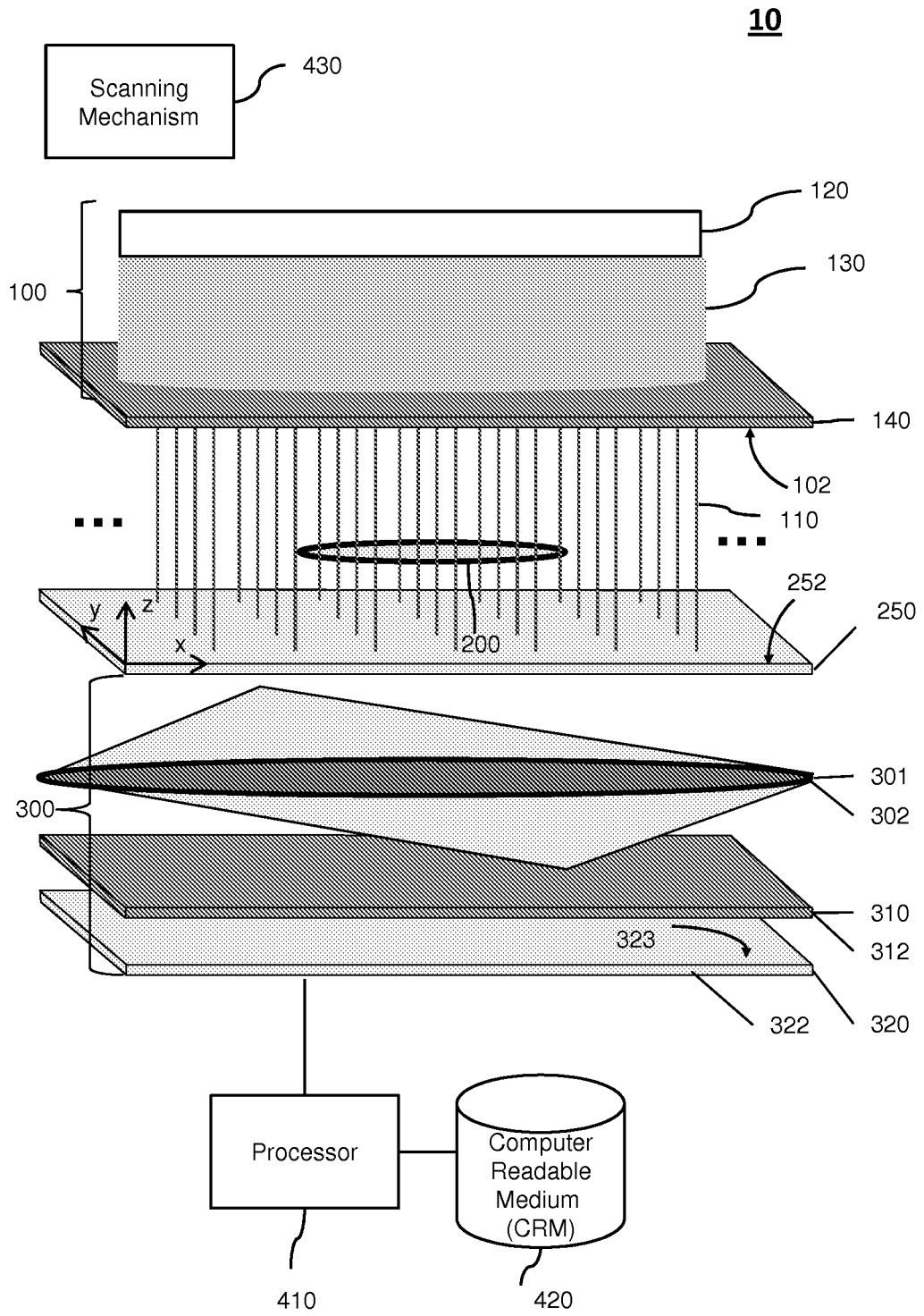

FIG. 3

10

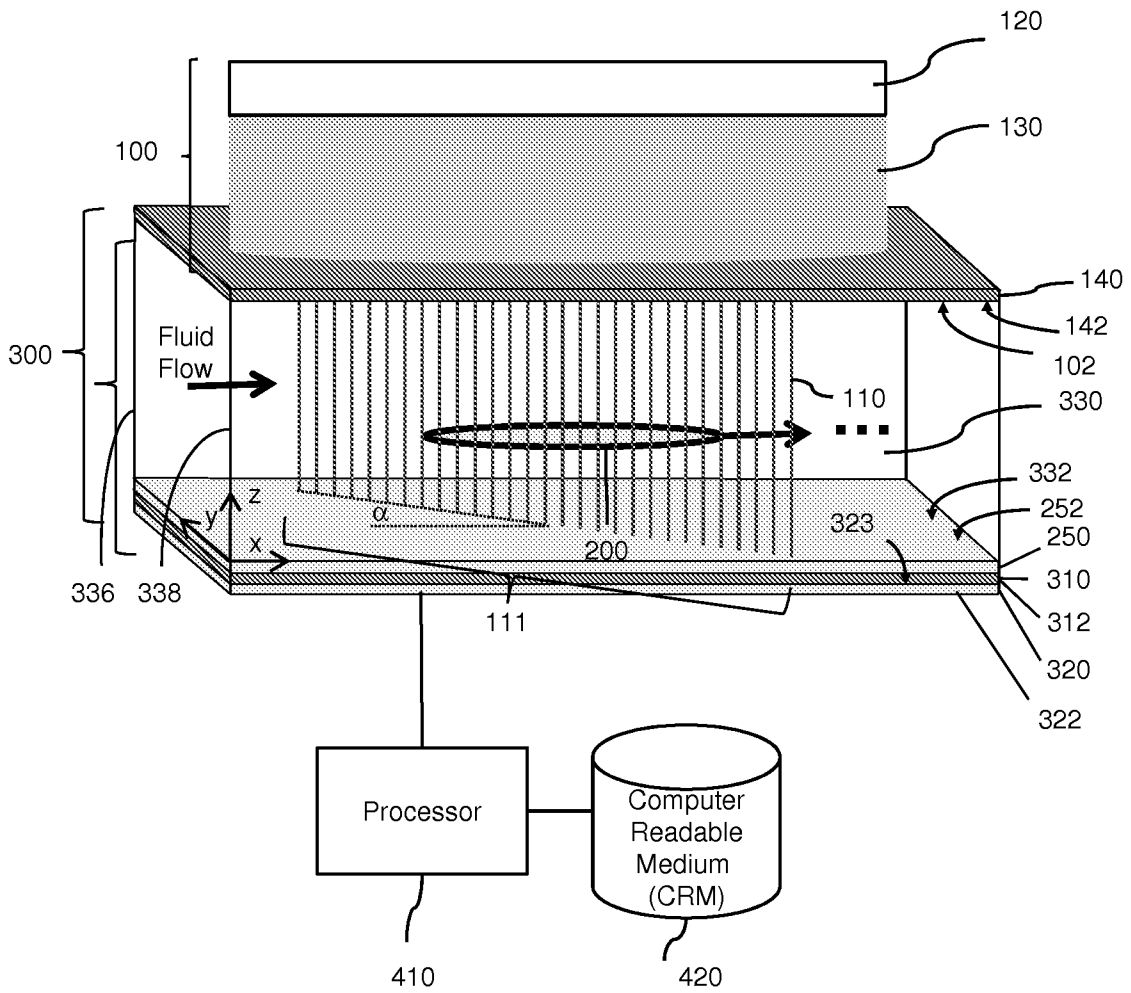

FIG. 4

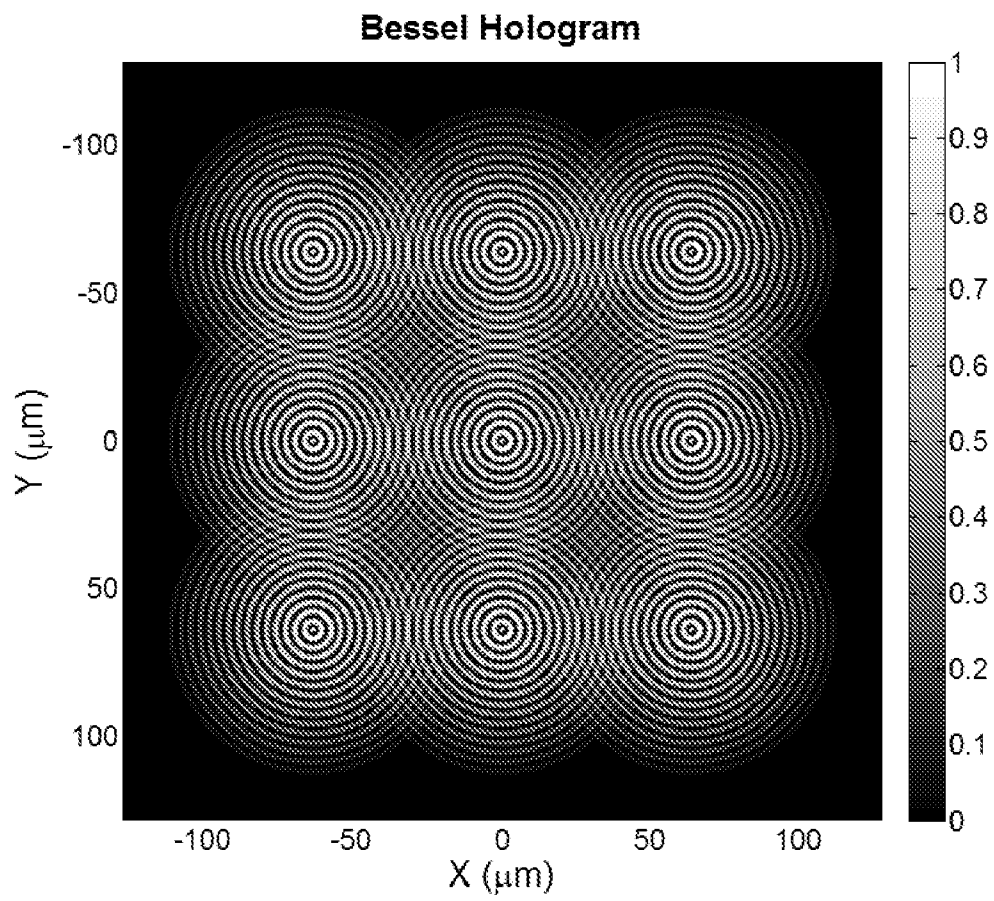

FIG. 5

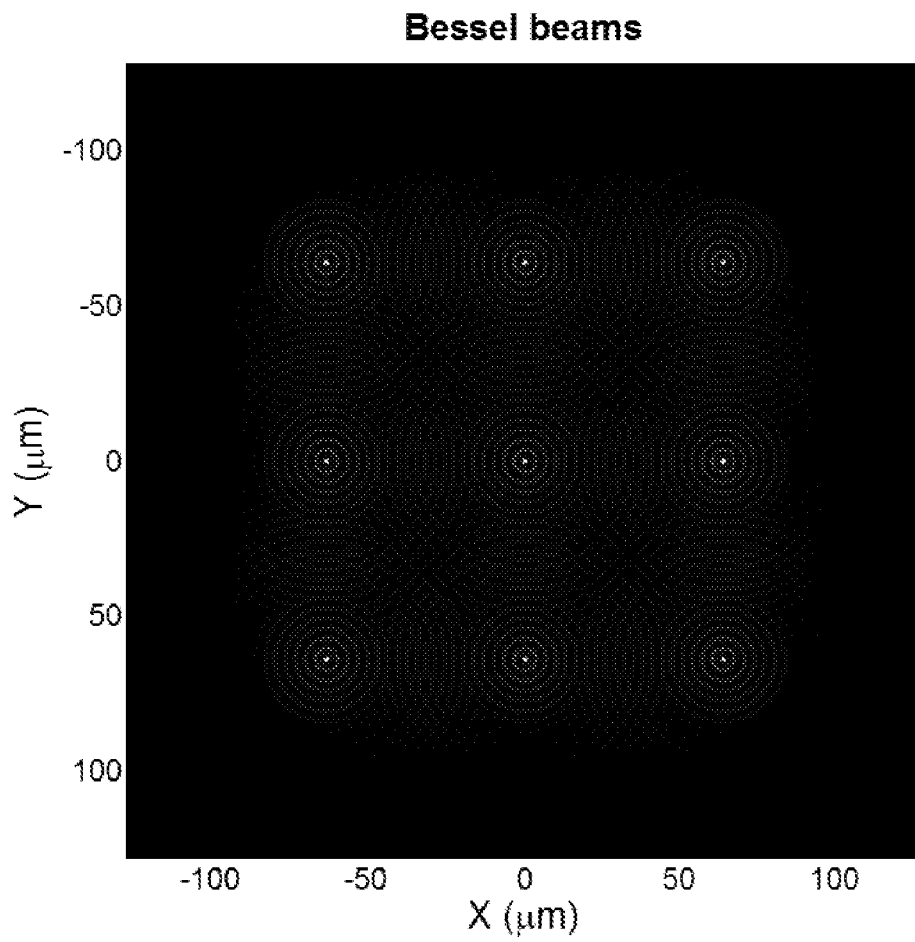

FIG. 6

7/8

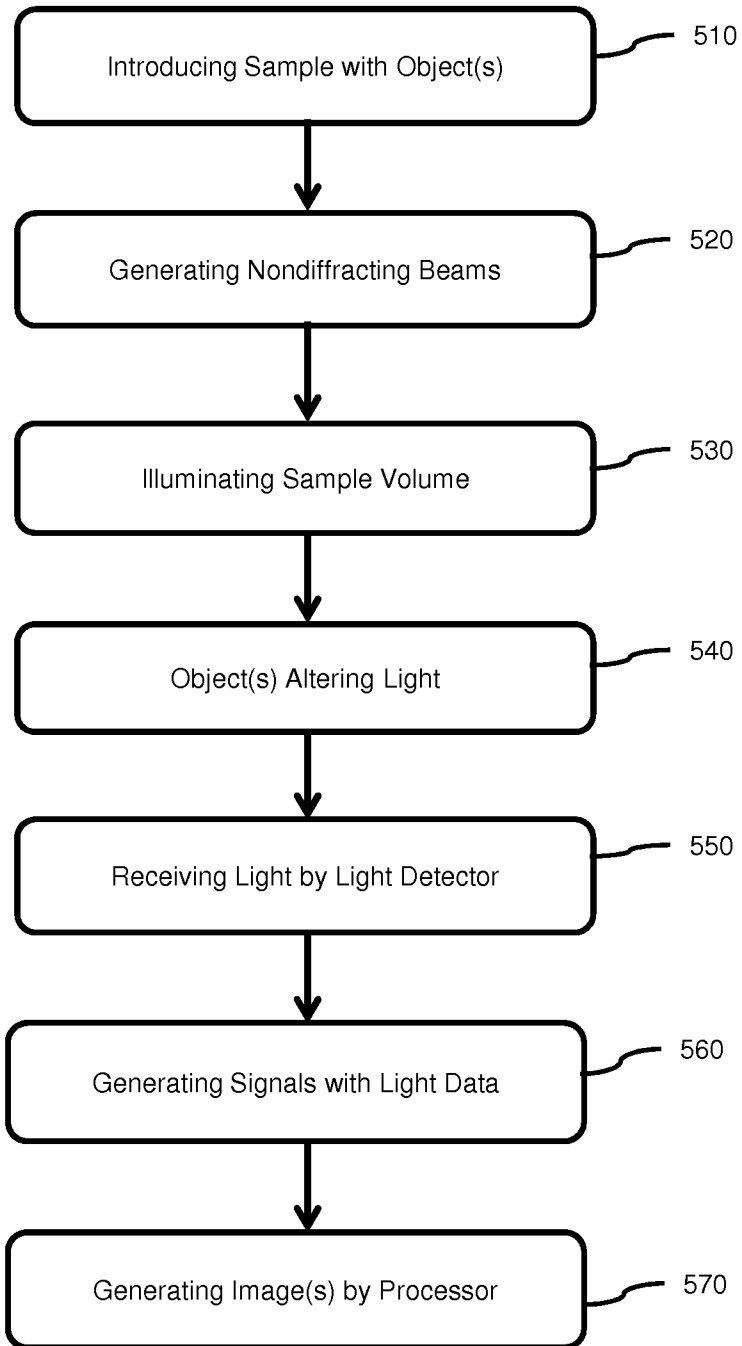

FIG. 7

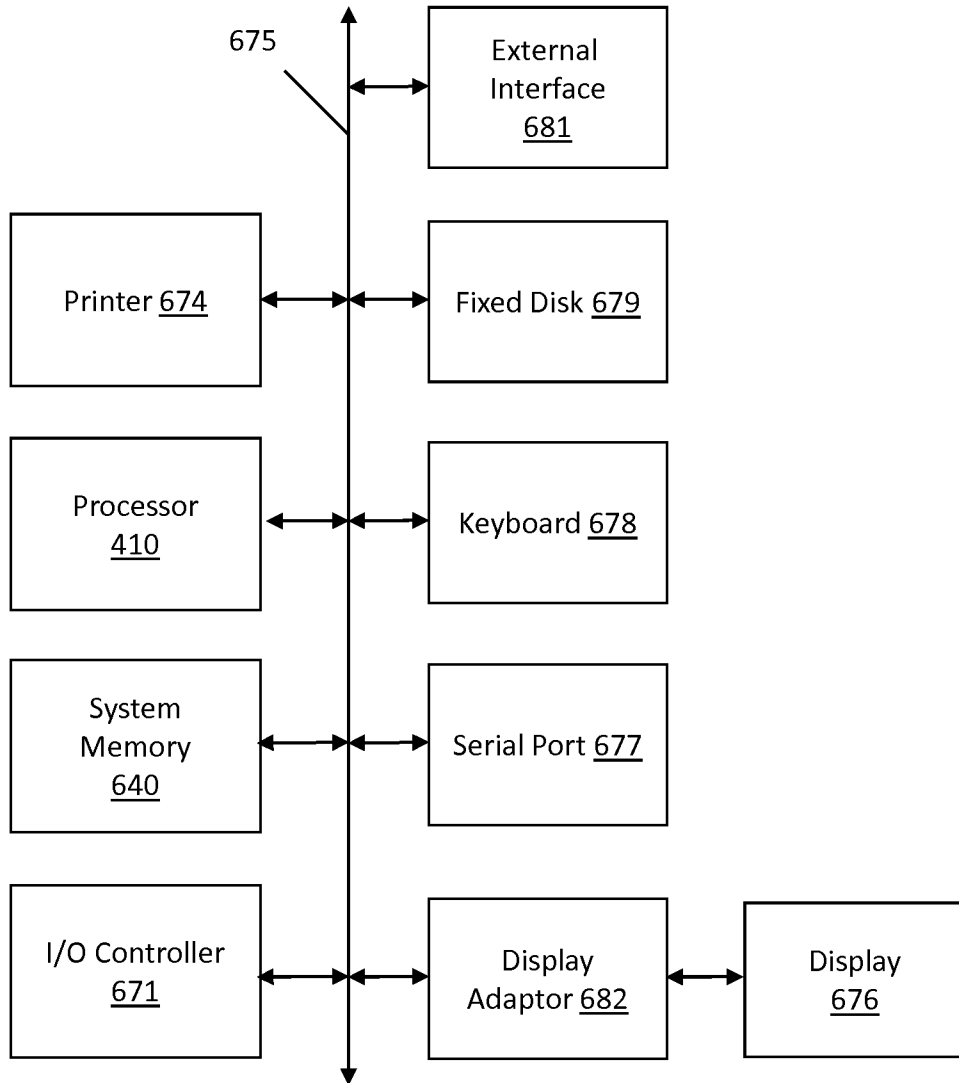

FIG. 8