

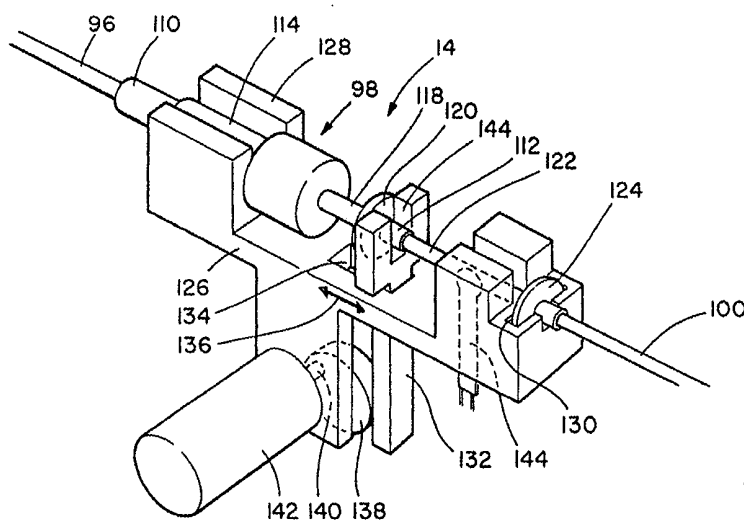

INTERNATIONAL APPLICATION PUBLISHED UNDER THE PATENT COOPERATION TREATY (PCT)

<p>(51) International Patent Classification ⁷ : A61M 5/142</p>	<p>A1</p>	<p>(11) International Publication Number: WO 00/44420</p> <p>(43) International Publication Date: 3 August 2000 (03.08.00)</p>
<p>(21) International Application Number: PCT/US99/28885</p> <p>(22) International Filing Date: 3 December 1999 (03.12.99)</p> <p>(30) Priority Data: 09/243,373 1 February 1999 (01.02.99) US</p> <p>(71) Applicant: BAXTER INTERNATIONAL INC. [US/US]; One Baxter Parkway, Deerfield, IL 60015 (US).</p> <p>(72) Inventor: ROSS, Stephen, O.; 3745 Southridge Way, Ocean-side, CA 92056 (US).</p> <p>(74) Agents: KOWALIK, Francis, C. et al.; Baxter International Inc., One Baxter Parkway, Deerfield, IL 60015 (US).</p>		<p>(81) Designated States: AU, BR, CA, CN, CR, CZ, HU, IN, JP, KR, MX, NZ, PL, SG, TR, ZA, European patent (AT, BE, CH, CY, DE, DK, ES, FI, FR, GB, GR, IE, IT, LU, MC, NL, PT, SE).</p> <p>Published <i>With international search report.</i></p>

(54) Title: METERED DOSE INFUSION PUMP AND METHOD



(57) Abstract

An intravascular administration set (14) includes an axially actuated reciprocating pump head (98) having a pump head inlet (110) and a pump head outlet (112). An inlet tube (96) has a first end attached to the pump head inlet (110) and a second end adapted for coupling with a liquid reservoir. An outlet tube (100) has a first end coupled to the pump head outlet (112) and a second end adapted for coupling in liquid communication with a blood vessel of a patient. The pump head inlet (110) and the pump head outlet (118) of the axially reciprocating pump head (98) are disposed axially of the pump head (98). An intravascular infusion pump (80) incorporates the administration set (14) and includes a linear reciprocating drive (132) operatively associated with the pump head (98). The liquid reservoir may be a syringe (94) and liquid is pumped from the syringe by creating a negative pressure at the syringe outlet (108). A method of intravascular infusion of liquid utilizes the administration set (14) and linear reciprocating drive (132).

FOR THE PURPOSES OF INFORMATION ONLY

Codes used to identify States party to the PCT on the front pages of pamphlets publishing international applications under the PCT.

AL	Albania	ES	Spain	LS	Lesotho	SI	Slovenia
AM	Armenia	FI	Finland	LT	Lithuania	SK	Slovakia
AT	Austria	FR	France	LU	Luxembourg	SN	Senegal
AU	Australia	GA	Gabon	LV	Latvia	SZ	Swaziland
AZ	Azerbaijan	GB	United Kingdom	MC	Monaco	TD	Chad
BA	Bosnia and Herzegovina	GE	Georgia	MD	Republic of Moldova	TG	Togo
BB	Barbados	GH	Ghana	MG	Madagascar	TJ	Tajikistan
BE	Belgium	GN	Guinea	MK	The former Yugoslav Republic of Macedonia	TM	Turkmenistan
BF	Burkina Faso	GR	Greece	ML	Mali	TR	Turkey
BG	Bulgaria	HU	Hungary	MN	Mongolia	TT	Trinidad and Tobago
BJ	Benin	IE	Ireland	MR	Mauritania	UA	Ukraine
BR	Brazil	IL	Israel	MW	Malawi	UG	Uganda
BY	Belarus	IS	Iceland	MX	Mexico	US	United States of America
CA	Canada	IT	Italy	NE	Niger	UZ	Uzbekistan
CF	Central African Republic	JP	Japan	NL	Netherlands	VN	Viet Nam
CG	Congo	KE	Kenya	NO	Norway	YU	Yugoslavia
CH	Switzerland	KG	Kyrgyzstan	NZ	New Zealand	ZW	Zimbabwe
CI	Côte d'Ivoire	KP	Democratic People's Republic of Korea	PL	Poland		
CM	Cameroon	KR	Republic of Korea	PT	Portugal		
CN	China	KZ	Kazakstan	RO	Romania		
CU	Cuba	LC	Saint Lucia	RU	Russian Federation		
CZ	Czech Republic	LI	Liechtenstein	SD	Sudan		
DE	Germany	LK	Sri Lanka	SE	Sweden		
DK	Denmark	LR	Liberia	SG	Singapore		
EE	Estonia						

Metered Dose Infusion Pump and Method

TECHNICAL FIELD

5 The present invention is directed toward infusion pumps, and more particularly toward a metered dose infusion pump, an administration set for an infusion pump and method for delivering a select volume of fluids for intravascular injection into a patient.

BACKGROUND ART

10 The use of infusion pumping devices for intravascular delivery of fluids to patients in hospitals or other patient care locations has increased dramatically in recent years. Infusion pumps have replaced gravity controlled infusion systems in many applications because of their greater accuracy of delivery rates and dosages and their ability to permit varying medication delivery profiles to optimize medication effectiveness. Infusion pumps have been particularly
15 useful for delivering dangerous medications to patients over an extended period of time in precisely measured and timed volumes to maximize drug effectiveness and patient safety.

 In order to assure administration of precise volumes of potentially dangerous drugs, the trend has been to produce ever more sophisticated pumping apparatuses. While the art has been successful in improving pump accuracy, there have been some serious drawbacks.

20 Most importantly, many of these pumps rely on highly precise and complicated driving apparatuses and pump head structures which increase pump complexity and cost. For example, while there has been much effort to design more accurate peristaltic pumps which rely upon a low cost IV tube as a disposable pump chamber, the drive toward increased accuracy has significantly complicated the pump structures and resulted in increased costs.

25 Manufacturers of pumps utilizing disposable cassettes as pump heads have also had problems producing low cost, highly reliable and accurate cassettes.

 The present invention is directed toward overcoming one or more of the problems discussed above.

30 SUMMARY OF THE INVENTION

 A first aspect of the present invention is an intravascular administration set including an axially actuated reciprocating pump head having a pump head inlet and a pump head outlet. An inlet tube has a first end attached to the pump head inlet and a second end adapted for coupling with a liquid reservoir. An outlet tube has a first end coupled to the pump head

-2-

outlet and a second end adapted for coupling in liquid communication with a blood vessel of a patient. The pump head inlet and the pump head outlet of the reciprocating pump head are preferably disposed axially of the pump head. The administration set may include a liquid reservoir connected to the second end of the inlet tube, with the liquid reservoir consisting of a syringe. In a preferred embodiment, the axially actuated reciprocating pump head includes a piston slidably received in the cylinder, the piston being movable within the cylinder between a discharged position and a recharged position to draw liquid into the pump head inlet and discharge liquid from the pump head outlet. A control valve is provided in fluid communication with the cylinder to promote the flow of liquid into the cylinder exclusively from the pump head inlet as the piston moves from the discharged position to the recharged position and to promote the flow of liquid exclusively out of the pump head outlet as the piston moves from the recharged position to the discharged position. A linkage is attached to the piston for moving the piston between the discharged and the recharged positions and the linkage is configured for engagement with a linear reciprocating drive.

A second aspect of the present invention is an intravascular infusion pump including an axially actuated reciprocating pump head having a pump head inlet and a pump head outlet. A housing includes a pump head receptacle receiving the pump head. A liquid reservoir is coupled in liquid communication to the pump inlet by an inlet tube. An outlet tube has a first end coupled in liquid communication with the pump head outlet and a second end adapted for coupling in liquid communication with a blood vessel of a patient. A linear reciprocating drive within the housing is operatively associated with the pump head to drive the pump head. Preferably, the liquid reservoir is also contained within the housing. Also in the preferred form, a controller is operatively associated with the reciprocating linear drive for controlling programmed operation of the pump head to deliver a desired output profile. In a further preferred embodiment, the axially actuated reciprocating pump head includes a piston slidably received in the cylinder, the piston being movable axially within the cylinder between a discharged position and a recharged position to draw liquid into the pump head inlet and discharge liquid from the pump head outlet. A control valve in liquid communication with the cylinder causes the flow of liquid into the cylinder exclusively from the pump head inlet as the piston moves from the discharged position to the recharged position and causes the flow of liquid exclusively out of the pump head outlet as the piston moves from the recharged position to the discharged position. A linkage attached to the piston moves the piston between

-3-

the discharged position and the recharged position. The linkage is engaged with the linear reciprocating drive. The linear reciprocating drive preferably includes an electric motor having a rotating drive shaft and a rotary to linear converter operatively associated with the drive shaft and the axially actuated reciprocating pump head to drive the pump head. The rotary to linear converter may comprise a cam eccentrically attached to the drive shaft of the electric motor and a cam follower biased into contact with the edge of the cam. As the cam rotates, the cam follower, which is connected to the axially actuated reciprocating pump head, is linearly reciprocated. An encoder associated with the electric motor is electrically coupled to the controller to enable precise monitoring of the pump output.

10 A third aspect of the present invention is a method of intravascular infusion of liquids to a patient. The method includes providing an axially actuated reciprocating pump head having a pump head inlet and a pump head outlet and providing inlet and outlet tubes. A first end of the inlet tube is coupled in liquid communication with the pump head inlet and a second head of the inlet tube is coupled in liquid communication with the liquid reservoir.

15 The first end of the outlet tube is coupled in liquid communication with the pump head outlet and the second end is coupled in liquid communication with a blood vessel of a patient. The reciprocating linear drive is linked in operative association with the pump head and actuated to drive liquid from the liquid reservoir to the blood vessel of a patient. In a preferred embodiment of a the method, the axially actuated reciprocating pump head is a nasal metered dose spray pump mechanism including an atomizer and the method further includes disabling the atomizer.

The intravascular administration set of the present invention utilizes and extremely light weight axially actuated reciprocating pump head that has been used for administration of aerosols to the noses of patients for years in tens of millions of manually actuated reciprocating nasal metered dose spray pumps. As a result, the pump head is available off the shelf in virtually unlimited quantities, making it extremely low cost. In addition, the simple pump head mechanism has proved its accuracy and reliability in millions of applications. Because of its low cost, the administration set is readily disposable, therefore furthering sanitary and safety objectives. The extreme light weight of the pump head facilitates its use with ambulatory infusion pumps. Because the pump head requires simple linear actuation to produce an accurate output, a wide variety of linear reciprocating drives are available for use with an infusion pump incorporating the axially actuated reciprocating pump head. An

-4-

infusion pump utilizing the pump head can provide substantially continuous flows of liquid or bolus infusions of liquid. It can also deliver highly accurate volumes of liquid over a large number of cycles of actuation of the pump head.

5 BRIEF DESCRIPTION OF THE DRAWINGS

Fig 1 is a schematic diagram illustrating an intravascular infusion pump of the present invention;

Fig. 2 is a perspective view of an embodiment of intravascular infusion pump of the present invention utilizing a syringe reservoir;

10 Fig. 3 is a perspective view the pump mechanics and administration set of the intravascular infusion pump of Fig. 2;

Fig. 4 is an exploded view of a representative axially reciprocating pump head deployed in the intravascular infusion pump of the present invention.

15 DETAILED DESCRIPTION OF THE PREFERRED EMBODIMENT

An intravascular infusion pump 10 of the present invention is shown in schematic form in Fig. 1. The intravascular infusion pump 10 consists of a pump body 12 and an administration set 14.

20 The administration set 14 consists of a pump head 16 which receives liquid from a reservoir 18 through an inlet tube 20 and delivers liquid through an outlet tube 22 to a patient interface 24 in liquid communication with a blood vessel of a patient. The patient interface may be a needle, catheter or any other suitable device known in the art. An air-eliminating filter 26 is preferably provided in liquid communication with the outlet tube to remove any air bubbles which may have been introduced into the liquid prior to introduction of the liquid
25 to the patient. The pump head 16 most preferably consists of an axially actuated reciprocating pump head with a pump head inlet 28 coupled in liquid communication to the inlet tube 20 and a pump head outlet 30 coupled in liquid communication with the outlet tube 22. As illustrated schematically in Fig.1, the pump head inlet 28 and outlet 30 are preferably coaxial.

30 Most preferably, the pump head 16 consists of an off the shelf nasal metered dose spray pump mechanism that has been modified to deactivate any atomizer so that air is not introduced into the liquid being pumped through the metered dose spray pump. One example of such a nasal metered dose spray pump is described in Haber *et al.*, U.S. Patent No. 5,433,191, the

-5-

disclosure of which is incorporated in its entirety herein. Other examples of suitable nasal metered dose spray pump mechanisms include those manufactured by Pfeiffer of Germany, including model no. 10358BSK 5635 (100 uL) and model no. 6958.59002/6000 (50 uL). Each of these representative pump heads have coaxial pump inlets and outlets and are actuated
5 by axial reciprocation.

The pump body 12 includes a housing 36 for encasing the pump electronics and drive apparatus. A controller 38 is provided in the housing for controlling operation of the pump drive. The controller 38 preferably includes microprocessor and memory programmable with selected functions for controlling and monitoring operation of the pumping mechanism and
10 administering a select delivery profile of liquid to a patient. Alternatively, as appreciated by one skilled in the art, various logic circuits could perform the functions of the controller, only such circuits would not have advantage of being reprogrammable as is the case with a microprocessor and associated memory.

The controller 38 is coupled by connector 40 to drive 42 which includes an encoder
15 44. The encoder 44 is in turn coupled to the controller by connector 46. The drive can be any suitable drive for providing linear reciprocating actuation to the pump head 16. The function of the encoder 44 is to provide a signal to the controller 38 indicative of the number of drive cycles and therefore pump head actuations to monitor pump output. Preferably, the drive 42 is an electric motor and the encoder is a Hall sensor. In such an embodiment, the drive shaft
20 48 of the electric motor is coupled to a rotary to linear converter 50 which in turn is operatively associated with the axially actuated reciprocating pump head 16 by linkage 52 which may, for example, be a cam follower or the like. Alternatively, the drive 42 could be an electric solenoid or pneumatically actuated cylinder capable of directly imparting linear reciprocation to the pump head 16. The pump body 12 also preferably includes a receptacle
25 53 for receiving the pump head 16 and the other components of the administration set 14 and for retaining the administration set 14 in operative association with the pump drive apparatus and sensors described below.

The pump body 12 also includes a variety of sensors. A position sensor 54 is connected to the controller by connector 56 sends a signal to the controller indicating the
30 pump head 16 is properly positioned in the receptacle 53. The controller is programmed so that if such a signal is not received, an appropriate warning signal is provided to the user.

-6-

An outlet pressure sensor 58 is connected to the controller by connector 60. The outlet pressure sensor is operatively associated with the outlet tube 22 of the administration set 14 for detecting increases in pressure within the outlet tube 22 indicative of a downstream occlusion. An inlet pressure sensor 62 is joined to the controller by connector 64 and is
5 operatively associated with the inlet tube 20 for sensing decreases in pressure in the inlet tube 20 indicative of a lack of fluid upstream of the pump head 16, which may occur when the reservoir 18 is depleted. The controller 38 is joined by connector 66 to power supply 68. The power supply 68 may be a battery or a connection to a standard ac outlet including an appropriate ac/dc adapter. A further sensor may be provided in association with the power
10 supply to sense electrical power status. All of the sensors provide signals through their respective connectors to the controller 38. The controller 38 is appropriately programmed to receive and process the sensor signals it receives. The appropriate displays or alarms are conveyed to the user through the display 70 connected to the controller by the connector 72. In addition to displaying warning signals, the display conveys useful information to the pump
15 user such as pump rate, volume pumped, delivery profile and the like. The display may be a conventional LCD dot matrix display. User inputs 74 are coupled to the controller by connector 76. Through the inputs the user dictates pump operation. The controller 38 responds to the various inputs and controls the pumping mechanism accordingly.

The infusion pump 10 may be designed as a disposable with the administration set 14
20 permanently enclosed in the housing 36. Obviously, such an embodiment would eliminate the need for a position sensor 54. Alternatively, the pump body is reusable and the administration set is a disposable.

A syringe pump embodiment 80 of the intravascular infusion pump of the present invention is illustrated in Fig. 2. The syringe pump embodiment 80 has a rigid housing 82
25 which includes an enclosure 84 encasing the pump mechanics and electronics. A display 86, such as a conventional LCD dot matrix display and a variety of inputs 88 are in the cover 90 of the enclosure 84. The housing also defines a elongate receptacle 92 for receiving the administration set 14. In this embodiment, the administration set 14 consists of a syringe 94 joined by an inlet tube 96 to an actually reciprocating pumping head 98 and an outlet tube 100
30 connected to the pump head outlet of the pump head 98.

The syringe 94 is of conventional construction well known in the art. Syringe 24 includes a cylinder 102 having an open distal end 104 which receives a plunger 106. The

-7-

proximal end of the cylinder 102 defines an outlet 108 for liquid contained in the cylinder 102. As readily appreciated by those skilled in the art, liquid may be drawn into the cylinder through the outlet 108 by withdrawing the plunger 106 or expunged by inserting the plunger.

The administration set 14 downstream from the syringe along with the pump mechanics are shown in greater detail in Fig. 3. The axially reciprocating pump head 98 includes a coaxial pump head inlet 110 and pump head outlet 112. Inlet tube 96 is connected to the pump head inlet 110 and outlet tube 100 is connected to the pump head outlet 112. The axially reciprocating pump head 98, which is shown in an exploded view in Fig. 3, consists of a cylinder 114 which defines a pump chamber and a piston 116 (*see*, Fig. 3) which reciprocatingly slides within the cylinder 114 between a discharged position with the volume of the pump chamber at a minimum and a recharged position with the volume of the pump chamber at a maximum. The piston 116 is actuated by a linkage 118 that also defines the pump head outlet 112. The linkage further includes a push plate 120 for facilitating actuation of the linkage as will be described in greater detail below. The push plate 120 is shown as a separate element from the linkage 118 in Fig. 4.

The administration set is maintained in operative association with the pump drive by means of a holding block 126. The holding block 126 defines a bracket 128 which receives the cylinder 114 of the axially reciprocating pump head 98. A push capture plate adapter 124 is received within a slot 130 defined in the holding block 126. A cam follower 132 rides within the gap 134 in the block 126 and is reciprocatingly linearly actuated in the directions of the arrow 136 by a cam 138 eccentrically mounted to a shaft 140 of an electric motor 142. As should be evident from Fig. 3, as the shaft 140 rotates, the cam follower 132 reciprocates linearly along the axis of the axially actuated pump head 98 by engagement of the cam follower with the edge of the cam 138. A spring, not shown, may be used to bias the cam follower into contact with a cam. The distal end of the cam follower 132 defines a slot 144 which receives the linkage 118 of the administration set and acts against the push plate 120 to axially actuate the pump head 98.

The outlet tube 100 is preferably a standard IV tube, which is typically made of polyvinyl chloride (PVC). The outlet tube 100 may include a silicone section 122 which is joined to the main body of the outlet tube 100 by the capture plate/adaptor 124. The PVC IV tube (or the silicone section 122) is received between a force sense resistor 144 which functions as the outlet pressure sensor 58 described above with regard to Fig. 1. The force

-8-

sense resistor detects expansion of the tube associated with an increase in pressure caused by a downstream occlusion and sends a signal to the controller when a select pressure is exceeded.

A representative axially actuated reciprocating pump head 98 is shown exploded in Fig. 3. The pump head 98 includes a cylinder 114 within which rides the piston 116. More particularly, a ball 146 is received in the cylinder 114 and abuts a reduced diameter portion 148 in the cylinder 114. A spring 150 is next received within the cylinder and it abuts a flange (not shown) within the cylinder adjacent to the reduced diameter portion 148. Next, a stem 152 is axially inserted within the cylinder and engages a distal end of the spring 150. The piston 116 is received over the stem 150 as is the linkage 118. The orifice 154 within the linkage 118 defines a conduit which feeds liquid to the pump head outlet 112. A cap 156 engages with a flange 158 on the cylinder 114 to maintain the various components of the axially reciprocating pump head 98 in their assembled position. The push plate 120 receives the distal end of the linkage 118 in the hole 159 which terminates the pump head outlet 118.

The pump head pumps fluid through the cylinder by axially depressing the linkage 118 via the push plate 120 into the cylinder which moves the piston 116 to a discharged position. Upon relaxing the axial force on the linkage 118, the piston 116 is biased to a recharged position by the spring 150. As the piston is forced toward the recharged position from the discharge position the ball 146 occludes the pump inlet 110 at the reduced diameter portion 148. Thus, liquid within the cylinder is driven out of the pump outlet. As the spring biases the piston to the recharged position, occluding pressure on the ball 146 is relaxed and fluid flows in the pump inlet 110. Liquid is prevented from flowing in the pump outlet 112 of the linkage 118 by a one-way check valve (not shown).

The pump head discharge stroke can be a series of incremental segments of a full discharge strike to provide small volume bolus dosages or can be a continuous full discharge stroke with a rapid return to provide a substantially continuous liquid flow. As would be appreciated by one skilled in the art, the cam profile may be designed to allow the spring in the pump head mechanism to substantially instantaneously move the pump plunger from the discharged to the recharged position and begin another discharge portion of the pump stroke.

Although not shown, the syringe 94 could be replaced with a standard IV bag. Obviously, this would require modification to the rigid housing 82. Alternatively, the supply

-9-

of liquid could be remote from the pump housing and delivered to the administration set 14 through the inlet tube 96 coupled to a remote reservoir.

The infusion pump and administration set of the present invention utilize a standardized pump head which has been shown through millions of uses as a nasal metered
5 dose spray pump to be accurate and highly reliable. As a result, the cost of the administration set is minimized without sacrificing accuracy or reliability. The simple linear actuation of the pump head makes it operable with many different forms of reciprocating linear drives including very simple, inexpensive and highly reliable mechanisms. The administration set may be deployed with a pump unit including a preprogrammed microprocessor which enables
10 infusion of a variety of delivery profiles.

-10-

CLAIMS

What is claimed is:

1. An intravascular administration set comprising:
an axially actuated reciprocating pump head having a pump head inlet and a pump
5 head outlet;
an inlet tube having first and second ends with the first end coupled in liquid
communication to the pump head inlet and the second end adapted for coupling in liquid
communication with a liquid reservoir; and
an outlet tube having first and second ends with the first end coupled in liquid
10 communication to the pump head outlet and the second end adapted for coupling in liquid
communication with a blood vessel of a patient.
2. The intravascular administration set of claim 1 wherein the axially actuated
reciprocating pump comprises a piston slidably received in a cylinder, the piston being
15 movable axially within the cylinder between a discharged position and a recharged position
to draw liquid into the pump head inlet and discharge liquid from the pump head outlet.
3. The intravascular administration set of claim 2 wherein the axially actuated
reciprocating pump head further comprises a control valve in fluid communication with the
20 cylinder to cause the flow of liquid into the cylinder exclusively from the pump head inlet as
the piston moves from the discharged position to the recharged position and to cause the flow
of liquid exclusively out the pump head outlet as the piston moves from the recharged position
to the discharged position.
- 25 4. The intravascular administration set of claim 2 wherein the axially actuated
reciprocating pump head further comprises a linkage attached to the piston for moving the
piston between the discharged and the recharged positions, the linkage being configured for
engagement with a linear reciprocating drive.
- 30 5. The intravascular administration set of claim 1 further comprising a liquid
reservoir in liquid communication with the second end of the inlet tube, the liquid reservoir
comprising a syringe having a cylinder with an open first end and a second end defining a

-11-

liquid outlet and a plunger slidingly received in the open first end, the second end of the inlet tube being coupled to the liquid outlet of the cylinder.

6. The intravascular administration set of claim 1 wherein the pump head inlet
5 and the pump head outlet of the reciprocating pump head are disposed axially of the pump head.

7. An intravascular infusion pump comprising:
an axially actuated reciprocating pump head having a pump head inlet and a
10 pump head outlet;
a housing having a pump head receptacle receiving the pump head;
a liquid reservoir;
an inlet tube having first and second ends with the first end coupled in liquid
communication to the pump head inlet and the second end coupled in liquid communication
15 with a liquid reservoir;
an outlet tube having first and second ends with the first end coupled in liquid
communication to the pump head outlet and the second end adapted for coupling in liquid
communication with a blood vessel of a patient; and
a linear reciprocating drive within the housing operatively associated with the pump
20 head.

8. The intravascular infusion pump of claim 7 wherein the liquid reservoir is
contained within the housing.

25 9. The intravascular infusion pump of claim 7 wherein the liquid reservoir
comprises a syringe having a cylinder with an open first end and a second end defining a
liquid outlet and a plunger slidingly received in the open first end, the second end of the inlet
tube being coupled to the liquid outlet of the cylinder.

30 10. The intravascular infusion pump of claim 7 wherein the liquid reservoir
comprises an IV bag.

-12-

11. The intravascular infusion pump of claim 7 wherein the axially actuated reciprocating pump head comprises a piston slidably received in a cylinder, the piston being movable axially within the cylinder between a discharged position and a recharged position to draw liquid into the pump inlet and discharge liquid from the pump and a control valve in
5 liquid communication with the cylinder to cause the flow of liquid into the cylinder exclusively from the pump head inlet as the piston moves from the discharged position to the recharged position and to cause the flow of liquid exclusively out the pump head outlet as the piston moves from the recharged position to the discharged position and a linkage attached to the piston for moving the piston between the discharged and the recharged positions, the
10 linkage engaging with the linear reciprocating drive.

12. The intravascular infusion pump of claim 7 wherein the linear reciprocating drive comprises an electric motor having a rotating drive shaft and a rotary to linear converter operatively associated with the drive shaft and the axially actuated reciprocating pump head
15 to drive the pump head.

13. The intravascular infusion pump of claim 12 wherein the rotary to linear converter comprises a cam having an edge, the cam being attached eccentrically to the drive shaft and a cam follower operatively engaged with the edge of the cam and biased into contact
20 with the edge of the cam, whereby as the cam rotates the cam follower is linearly reciprocated, the cam follower being connected to the axially actuated reciprocating pump to drive the pump head.

14. The intravascular infusion pump of claim 7 further comprising controller
25 operatively associated with the reciprocating linear drive for controlling preprogrammed operation of the pump head.

-13-

15. The intravascular infusion pump of claim 14 further comprising a pressure transducer operatively associated with the outlet tube and coupled to the controller for detecting downstream occlusions.

5 16. The intravascular infusion pump of claim 14 further comprising an encoder operatively associated with the linear drive and coupled to the controller for delivering a signal indicative of pump output to the controller.

10 17. A method of intravascular infusion of liquids to a patient comprising:
providing an axially actuated reciprocating pump head having a pump head inlet and a pump head outlet;
providing an inlet tube and an outlet tube, each having first and second ends;
coupling the first end of the inlet tube in liquid communication with the pump head inlet and the second end of the inlet tube in liquid communication with a liquid reservoir;
15 coupling the first end of the outlet tube in liquid communication with the pump head outlet and the second end in liquid communication with a blood vessel of a patient;
linking a reciprocating linear drive in operative association with the pump head; and
actuating the reciprocating linear drive.

20 18. The method of claim 17 further comprising providing an encoder operatively associated with the reciprocating linear drive for producing a signal upon each reciprocation of the above;
providing a controller connected to the encoder to receive the signal to the reciprocating linear drive; and
25 programming the controller to control the rate of actuation of the linear drive and to calculate pump head output based upon signals received from the encoder.

30 19. The method of claim 17 wherein the axially actuated reciprocating pump head comprises a nasal metered dose spray pump mechanism including an atomizer, the method further comprising disabling atomizer.

-14-

20. The method of claim 17 further comprising providing a syringe as the reservoir, the syringe being a cylinder with an open first end and a second end defining a liquid outlet and plunger received in the open first end;

coupling the second end of the inlet tube to the liquid outlet of the syringe cylinder;

5 and

creating a negative pressure on the liquid outlet of the syringe to withdraw liquid from the syringe by actuating the reciprocating linear drive.

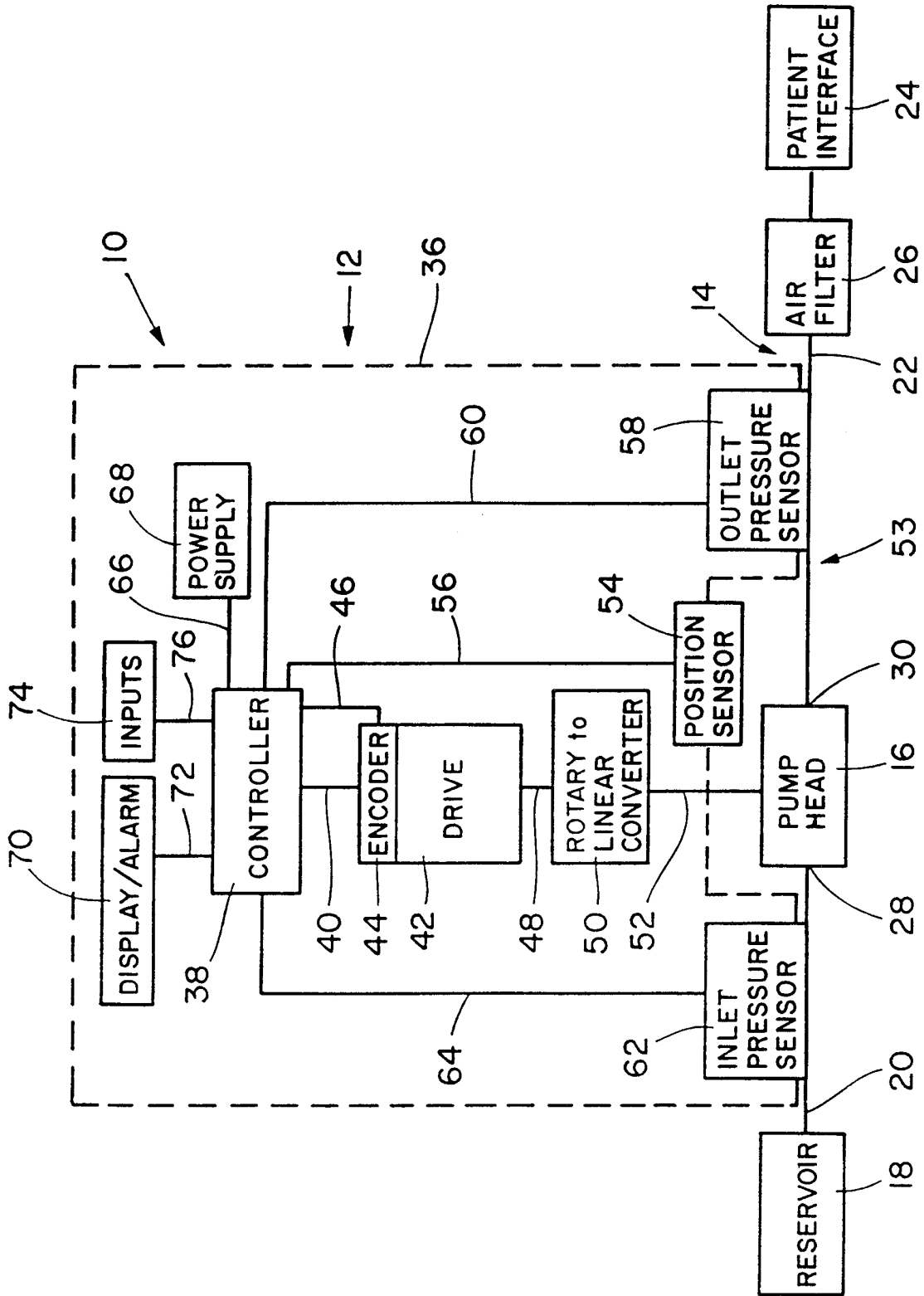

FIG. 1

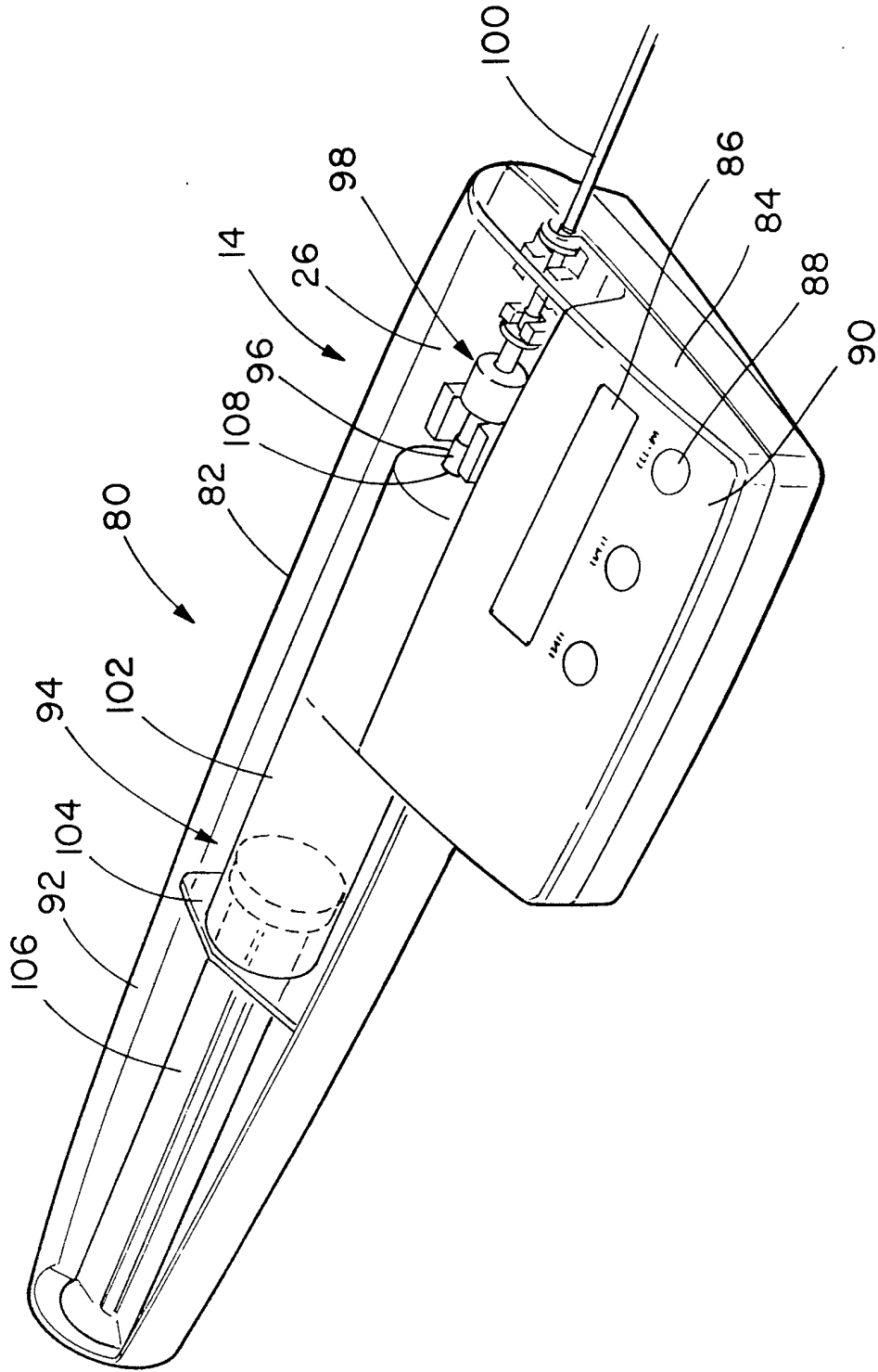

FIG. 2

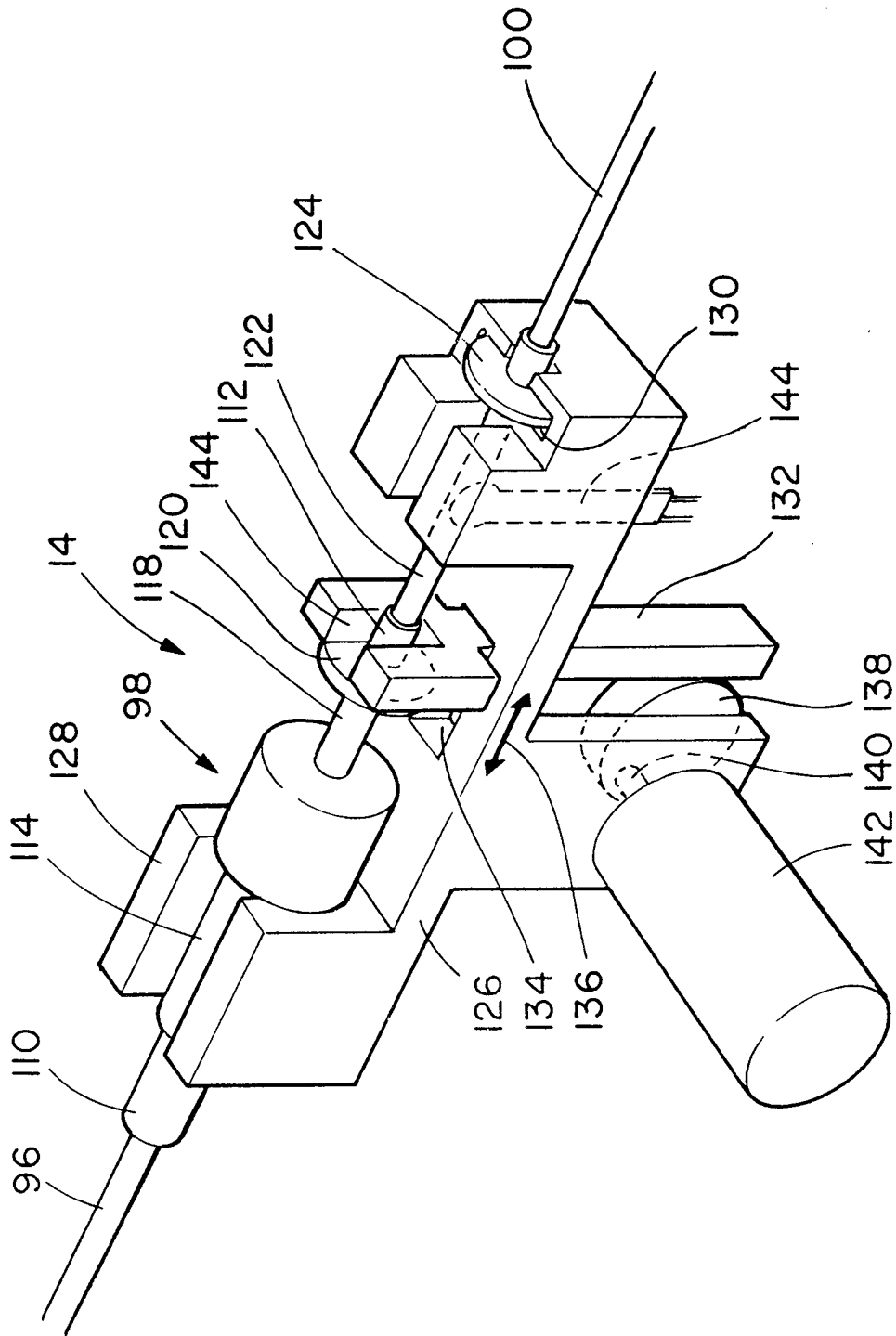

FIG. 3

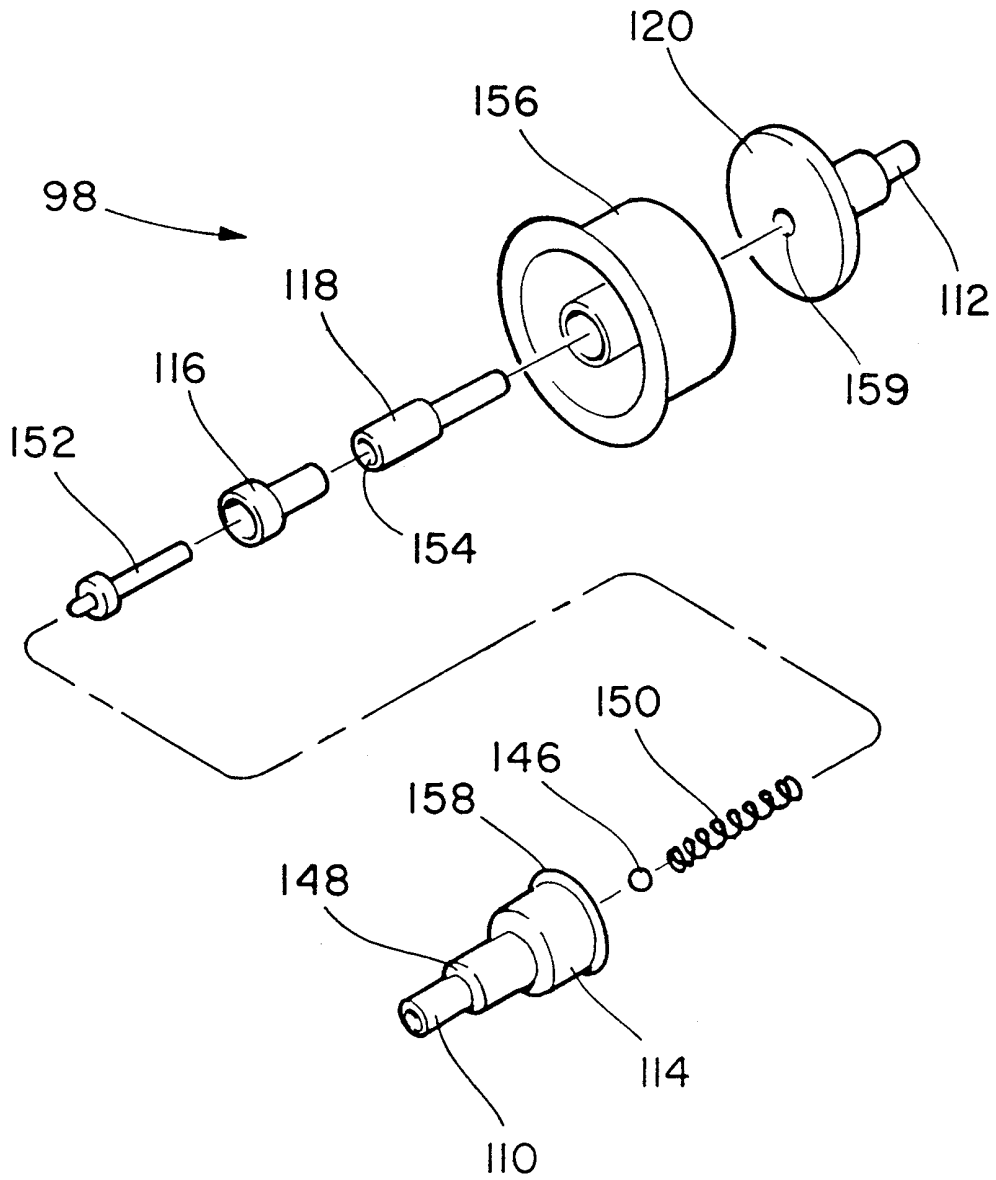

FIG. 4

INTERNATIONAL SEARCH REPORT

International Application No

PCT/US 99/28885

A. CLASSIFICATION OF SUBJECT MATTER
 IPC 7 A61M5/142

According to International Patent Classification (IPC) or to both national classification and IPC

B. FIELDS SEARCHED

Minimum documentation searched (classification system followed by classification symbols)
 IPC 7 A61M

Documentation searched other than minimum documentation to the extent that such documents are included in the fields searched

Electronic data base consulted during the international search (name of data base and, where practical, search terms used)

C. DOCUMENTS CONSIDERED TO BE RELEVANT

Category °	Citation of document, with indication, where appropriate, of the relevant passages	Relevant to claim No.
X	EP 0 654 278 A (SARCOS GROUP) 24 May 1995 (1995-05-24) column 9, line 53 - line 54 column 10, line 45 - column 12, line 10 column 23, line 33 - line 36 figures 3,5,22,23	1-4,6-8, 10-12,14
X	WO 97 42410 A (SARCOS INC) 13 November 1997 (1997-11-13) page 13, line 20 - line 26 page 17, line 23 - page 18, line 6 figure 16	1
A	--- -/--	12,14,15

Further documents are listed in the continuation of box C.

Patent family members are listed in annex.

° Special categories of cited documents :

- *A* document defining the general state of the art which is not considered to be of particular relevance
- *E* earlier document but published on or after the international filing date
- *L* document which may throw doubts on priority claim(s) or which is cited to establish the publication date of another citation or other special reason (as specified)
- *O* document referring to an oral disclosure, use, exhibition or other means
- *P* document published prior to the international filing date but later than the priority date claimed

- *T* later document published after the international filing date or priority date and not in conflict with the application but cited to understand the principle or theory underlying the invention
- *X* document of particular relevance; the claimed invention cannot be considered novel or cannot be considered to involve an inventive step when the document is taken alone
- *Y* document of particular relevance; the claimed invention cannot be considered to involve an inventive step when the document is combined with one or more other such documents, such combination being obvious to a person skilled in the art.
- *&* document member of the same patent family

Date of the actual completion of the international search

25 April 2000

Date of mailing of the international search report

02/05/2000

Name and mailing address of the ISA

European Patent Office, P.B. 5818 Patentlaan 2
 NL - 2280 HV Rijswijk
 Tel. (+31-70) 340-2040, Tx. 31 651 epo nl,
 Fax: (+31-70) 340-3016

Authorized officer

Sedy, R

INTERNATIONAL SEARCH REPORT

International Application No
PCT/US 99/28885

C.(Continuation) DOCUMENTS CONSIDERED TO BE RELEVANT		
Category °	Citation of document, with indication, where appropriate, of the relevant passages	Relevant to claim No.
X	US 5 582 593 A (HULTMAN BARRY W) 10 December 1996 (1996-12-10) column 11, line 11 - line 39 column 14, paragraph 1 figures 6,10,11	1
A	-----	16
A	EP 0 372 863 A (PACESETTER INFUSION LTD) 13 June 1990 (1990-06-13) column 15, line 26 - line 37 figures 13,14	5,9,10
A	-----	13
A	FR 2 300 576 A (GIRAUX JEAN) 10 September 1976 (1976-09-10) figures 1,2	13
A	-----	16
A	EP 0 447 985 A (ABBOTT LAB) 25 September 1991 (1991-09-25) figures 13,14 -----	16

INTERNATIONAL SEARCH REPORT

International application No.

PCT/US 99/ 28885

Box I Observations where certain claims were found unsearchable (Continuation of Item 1 of first sheet)

This International Search Report has not been established in respect of certain claims under Article 17(2)(a) for the following reasons:

1. Claims Nos.: 17-20
because they relate to subject matter not required to be searched by this Authority, namely:
Rule 39.1(iv) PCT - Method for treatment of the human or animal body by surgery
2. Claims Nos.:
because they relate to parts of the International Application that do not comply with the prescribed requirements to such an extent that no meaningful International Search can be carried out, specifically:
3. Claims Nos.:
because they are dependent claims and are not drafted in accordance with the second and third sentences of Rule 6.4(a).

Box II Observations where unity of invention is lacking (Continuation of Item 2 of first sheet)

This International Searching Authority found multiple inventions in this international application, as follows:

1. As all required additional search fees were timely paid by the applicant, this International Search Report covers all searchable claims.
2. As all searchable claims could be searched without effort justifying an additional fee, this Authority did not invite payment of any additional fee.
3. As only some of the required additional search fees were timely paid by the applicant, this International Search Report covers only those claims for which fees were paid, specifically claims Nos.:
4. No required additional search fees were timely paid by the applicant. Consequently, this International Search Report is restricted to the invention first mentioned in the claims; it is covered by claims Nos.:

Remark on Protest

- The additional search fees were accompanied by the applicant's protest.
- No protest accompanied the payment of additional search fees.

INTERNATIONAL SEARCH REPORT

Information on patent family members

Inte: onal Application No

PCT/US 99/28885

Patent document cited in search report	Publication date	Patent family member(s)	Publication date
EP 0654278 A	24-05-1995	US 5632606 A	27-05-1997
		CA 2135836 A	24-05-1995
		JP 7269459 A	17-10-1995
		US 5618163 A	08-04-1997
		US 5603354 A	18-02-1997
		US 5556263 A	17-09-1996
		US 5647575 A	15-07-1997
		US 5710401 A	20-01-1998
		US 5807075 A	15-09-1998
		US 5799690 A	01-09-1998
		US 5941533 A	24-08-1999
		US 5655779 A	12-08-1997
		US 5931647 A	03-08-1999
		US 5944495 A	31-08-1999
US 6007310 A	28-12-1999		
WO 9742410 A	13-11-1997	US 5807075 A	15-09-1998
		AU 2828297 A	26-11-1997
		EP 0897473 A	24-02-1999
US 5582593 A	10-12-1996	CA 2154390 A	22-01-1996
EP 0372863 A	13-06-1990	US 5009641 A	23-04-1991
		CA 2001942 A,C	02-06-1990
		DE 68916196 D	21-07-1994
		DE 68916196 T	19-01-1995
		JP 2264666 A	29-10-1990
FR 2300576 A	10-09-1976	NONE	
EP 0447985 A	25-09-1991	US 5039279 A	13-08-1991
		AU 641734 B	30-09-1993
		AU 7277291 A	19-09-1991
		CA 2038314 A	16-09-1991
		JP 4224288 A	13-08-1992
		US 5180287 A	19-01-1993